

PROPOSAL

FOR

TAS 24-9A D214913

RENOVATIONS TO WEEDSPORT SECTION
MAINTENANCE BUILDING AND ROOF REPLACEMENT
MILEPOST 304.2

BOOK 1 OF 1

THIS BOOK CONTAINS SPECIFICATIONS AND
BID PROPOSAL WORKSHEETS.

SUBMITTED IN ACCORDANCE WITH THE NEW YORK STATE
DEPARTMENT OF TRANSPORTATION STANDARD SPECIFICATIONS
OFFICIALLY ADOPTED JANUARY 1, 2024 EXCEPT AS MODIFIED
IN THE PLANS AND/OR PROPOSAL AND ANY CHANGES WITH
ARTICLE 2, TITLE 9 OF THE PUBLIC AUTHORITIES LAW.

LETTING OF

JANUARY 31, 2024

BIDS DUE: 10:30 A.M.

BIDS OPENED: 11:00 A.M.



**Thruway
Authority**

200 Southern Blvd., Albany, NY 12209

NOTICE **TO** **BIDDERS**

In addition to the bid deposit requirement, this Proposal shall be accompanied by a Statement of Surety's Consent on the form furnished by the Authority. (See last page).

BIDDERS ARE SUBJECT TO LOSS OF BID DEPOSIT FOR FAILURE TO OBTAIN PROPER BONDING.

Thruway Authority Designated Contacts

Pursuant to NYS Finance Law Sections 139-j and 139-k, the following people are the designated contacts for this procurement process:

For all technical or engineering related questions:

- Nick Tario
Project Designer
Nicholas.Tario@thruway.ny.gov

Or

- David T. Vosburgh, PE
Structures Design Bureau Director
David.Vosburgh@thruway.ny.gov

For all procurement contract process related questions:

- Ronald Smith
Office of Procurement Services
Ronald.Smith@thruway.ny.gov

Or

- Andrew Trombley
Office of Procurement Services
Andrew.Trombley@thruway.ny.gov

For more information about NYS Finance Law Sections 139-j and 139-k, please see the New York State Thruway Authority Guidelines for Lobbying included in this Proposal.

NEW YORK STATE THRUWAY AUTHORITY

NOTICE TO BIDDERS

The Thruway Authority conducts public bid openings. Visitors who choose to hand deliver a bid and/or witness the bid opening are limited to one person. The Thruway Authority also uses  YouTube to broadcast its live bid openings. The link to live streams are available from the Thruway website here: <https://www.thruway.ny.gov/news/meetings/bid-openings.html>

or directly from  YouTube at:

<https://www.youtube.com/@nysthruwayauthority6263/streams>

Sealed bids must be hand delivered, or delivered by first class mail, USPS Express or Priority Mail, or overnight delivery service (e.g., FedEx, UPS) to the New York State Thruway Authority Headquarters Building, at the following address only: New York State Thruway Authority, 200 Southern Boulevard Albany, NY 12209.

Sealed bids should not be sent or delivered to any other address or location, and the Authority is not responsible for any late deliveries or misdirected bids.

Regardless of the delivery method selected, all sealed bids, whether paper or electronic form, must be delivered by 10:30 A.M. on Wednesday, January 31, 2024, where they will be opened publicly and read aloud at 11:00 A.M. Any bids sent or delivered to an address or location other than the one specified above, or received after this time, will not be accepted.

Contract TAS 24-9A / D214913 Weedsport Maintenance – Addition to the Maintenance Section Building & Roof Replacement at MP 304.2 in Cayuga County in accordance with the Plans and Specifications.

Your bid must be secured with either a Bid Bond or a Bid Deposit. A Bid Bond must be in the amount of 5% of the total bid and must be on the Authority's Bid Bond Form (TA-44117) which is included in the Proposal. A Bid Deposit must be a certified check or cashier's check made payable to the New York State Thruway Authority in the amount of **\$75,000.00**

Plans, proposals, and information on how to download Contract Bid Data are available on the Authority's Website at www.thruway.ny.gov.

SPECIAL NOTE

The New York State Thruway Authority has discontinued the practice of reproducing and furnishing full-size and half-size plans to Contractors after contract award. Contractors shall be responsible for their own hard copies of plans and proposals at no additional cost to the Authority.

New York State Can Help You Secure Surety Bonding

The NYS Surety Bond Assistance Program (NYSBAP) provides technical and financial assistance to help contractors secure surety bonding. Contractors may be eligible to receive a guarantee of up to 30% to secure a surety bond line, bid bond or a performance and payment bond on State projects. Training is also available to contractors requiring technical support on how to become bond-ready. For more information and to fill out a NYSBAP application, visit <http://esd.ny.gov/BusinessPrograms/BondingAssistance.html> or contact Ms. Huey-Min Chuang at Empire State Development at 212-803-3238 or BAP@esd.ny.gov.

SPECIAL NOTE
REQUEST FOR INFORMATION (RFI)

A **request for information (RFI)** is a written process used to clarify a detail, specification, or note in the contract documents, provide notification of a possible error or omission, or request a minor modification due to possible unforeseen issues that may occur during construction.

However, during the period between project advertisement and award of contract, the prospective Bidder/Contractor shall submit all RFIs to the appropriate "Designated Contact" via e-mail, as listed elsewhere in the Proposal. The prospective Bidder's/Contractor's RFI shall be forwarded to the designated contact. The Bidder Request for Information, Thruway Authority form TA-W44137, can now be found on the Authority's website at:

<http://www.thruway.ny.gov/business/contractors/documents/ta-w44137.pdf>

This form should be filled out as completely and accurately as possible, numbered sequentially, as may be necessary, and saved in pdf format. Any supporting information that may help describe the issue more clearly, as well as any suggestions or recommendations for possible resolution, should also be provided. The form once complete shall be forwarded to the designated contact as instructed in the form.

Responses by the Authority to RFI's will be documented as Questions and Answers and posted for all bidders' reference, under each respective project, on the Thruway Authority's website at:

<http://www.thruway.ny.gov/business/contractors/documents/index.shtml>

Questions and Answers posted to the Authorities internet page may not be memorialized as amendments. Thus, prospective bidders are advised to check the Thruway Authority's website regularly before letting (or proposals are due), for Questions and Answers updates. Please be advised that RFI's submitted the week of the letting may not be answered.

Any changes to the Contract documents that result from an RFI will be addressed via an amendment.

New York State Thruway Authority

Contract No. TAS 24-9A

TABLE OF CONTENTS

PROJECT INFORMATION

Proposal Title Sheet	1
Pre-Award Notice / Contract Award	2
Pre-Bid Inspection / Preconstruction Meeting / Withdrawal of Bid	3
Work to be Done.....	4
Schedule and Suspension of Work.....	5
Project Notes.....	8
Supplemental Information Available to Bidders	12

REVISIONS TO NYSDOT STANDARD SPECIFICATIONS

NYSTA Addendum to the Standard Specifications	13
---	----

SPECIAL SPECIFICATIONS

Special Note — Special Specification Pay Item Numbers	14
Project Special Specifications.....	15

SPECIAL NOTES

Confidential Information.....	689
Control of Materials	692
Availability of Electronic Bid Data	693
Requirements for Contractor’s Utilization of Areas Outside of the Right-of-Way.....	694
Compliance with State Pollutant Discharge Elimination System (SPDES) Regulations.....	695
Diesel Emission Reduction Act (DERA) Regulatory Compliance	
Green Construction Requirements	696
“Generator Knowledge” for Disposal of Treated Wood	700
Forest Insect Disease Control	701
Marker Relocation During Construction	703
Project Special Notes	704

COMPLIANCE REQUIREMENTS AND PROCEDURES

Contract Goals for DBE/MWBE/SDVOB Participation	706
Chart A – Goals for Minority Participation	707
Minority/Women-Owned Business Enterprises (MWBEs) Reporting.....	709
Service-Disabled Veteran-Owned Business Enterprises (SDVOB)	713
Training Special Provisions	722
Workforce Utilization/Gross Wages Reporting.....	726
Reporting and Submission Schedules	728

STATE WAGE RATE INFORMATION

Wage Rates / Special Notice to Bidders in Relation to Overtime Dispensation 729
Special Note: State Prevailing Wage Rates..... 730
State Wage Rates 731

AGREEMENT, FAITHFUL PERFORMANCE BOND AND LABOR AND MATERIAL BOND

New York State Thruway Agreement..... 745
Faithful Performance Bond 769
Labor and Material Bond 775
(TAP-326 (11/2023) Appendix A – Standard Clauses for New York State
Thruway Authority Contracts 777

BID PROPOSAL

Itemized Proposal..... 782
Non-Collusive Bidding Certification..... 786
Iran Divestment Certification..... 787
MacBride Fair Employment Principals Certification 788
Certification Under Executive Order No. 16 Prohibiting State Agencies and
Authorities from Contracting with Businesses Conducting Business in Russia 789
Signature Sheet..... 790
Bid Bonds 791
New York State Thruway Authority Guidelines for Lobbying..... 794
Disclosure of Prior Non-Responsibility Determinations..... 797
Certificate of Compliance (TA-W2111-9) 798
Amendment Acknowledgment 799
Statement of Surety’s Consent 800

PROJECT INFORMATION

NEW YORK STATE THRUWAY AUTHORITY
DEPARTMENT OF ENGINEERING
PROPOSAL ESTIMATE FOR
RENOVATIONS TO THE WEEDSPORT SECTION
MAINTENANCE BUILDING AND ROOF REPLACEMENT

AT
MILEPOST 304.20

IN THE
SYRACUSE DIVISION

OF THE
NEW YORK STATE THRUWAY

IN
CAYUGA COUNTY

TYPE	LIMITS
Renovations (Addition) and Roof Replacement to the Weedsport Section Maintenance Building	Milepost 304.20

DEPOSIT REQUIRED \$75,000.00

COMPLETION DATE 11/08/2024

PRE-AWARD NOTICE

A Pre-Award Meeting has not been scheduled for this project. If a Pre-Award Meeting is deemed necessary, notice of the date and time will be provided.

To assist the Authority in its award process, the successful low bidder must furnish the following items upon request:

1. A current New York State Uniform Contracting Questionnaire (NYSUCQ) CCA-2 form must be on file;
2. A list of current contracts giving the firm or agency for which they are being performed, the name and phone number of someone therein familiar with the contractor's work, the contract amount, and percent of completion;
3. Pre-Award Project Schedule;
4. Documentation of the actions taken to comply with the Minority/Women's Business Enterprise Utilization goals (Non-Federal), or Disadvantaged Business Enterprise goals (Federal) as defined in the Proposal;
5. A "Schedule of Participation of Minority/Women's Business Enterprise" (Form TA-1022), or Disadvantaged Business Enterprise" (Form TA-1022F);
6. AAPHC-89 Approval to Subcontract.

Contract Documents will be supplied with the Authority's notice to the successful low bidder and must be executed and returned to the Authority within ten (10) days of receipt.

If a Pre-Award Meeting is held, it is requested that the Project Superintendent be present. The Contractor should be prepared to provide, upon request by the Authority, information regarding, among other things, the following:

1. Use of subcontractors, including who they will be and what items of work they will perform;
2. Suppliers and manufacturers;
3. Traffic control and safety;
4. Any anticipated problems that could affect the progression of the project.

CONTRACT AWARD

The award process cannot begin until the executed Contract Documents have been returned to the Authority and the successful Low Bidder has provided acceptable documentation with regard to his actions taken to comply with the M/WBE goals of this Contract or DBE Goals for Federally Aided Contracts.

ALL BIDDERS**PRE-BID INSPECTION**

The prospective bidder must have in its possession the Contract Plans/Proposal and a Work Permit for identification purposes when conducting a pre-bid inspection of the Thruway facility.

The prospective bidder shall inform the appropriate Division Point of Contact (listed below) prior to visiting the site and shall strictly comply with all instructions and requirements.

- **The New York State Thruway Authority Permit Application (TA-W5124)** and information on required insurance documentation is available at <http://www.thruway.ny.gov/business/realproperty/permits.html>. The application along with insurance documentation shall be submitted to the appropriate Thruway Authority Division Permit Coordinator as indicated on page 2 of the application. The fee is waived for this Pre-Bid Inspection.

<u>Division</u>	<u>Point of Contact</u>	<u>Phone</u>
New York	Permit Coordinator	(845) 918-2510
Albany	Gary Raylinsky	(518) 436-2710
Syracuse	Jerrin George	(315) 438-2391
Buffalo	Nicholas Przybylski	(716) 635-6253

Provisions of Section 107-05, Equipment Safety Procedures, contained in the Contract Proposal shall apply to all Pre-Bid Inspectors and shall be strictly adhered to while performing the pre-bid inspection.

PRECONSTRUCTION MEETING

A Pre-Construction Meeting will be held prior to the start of construction. The time, date and location will be coordinated by the Division Construction Engineer who will provide this information to the successful low bidder as soon as it is available.

WITHDRAWAL OF BID

A Contractor may at any time, upon at least fifteen (15) days written notice, withdraw its bid on a date sixty (60) days after bid opening or thirty (30) days after the properly executed contract documents have all been received by the Authority, whichever is later. The bid bond, bid deposit, and/or performance bond shall remain in effect until such period of written notice has expired provided the contract has not been approved by the Office of the State Comptroller in the interim.

The Contractor and the Authority may agree in writing to extend the date upon which the bid may be withdrawn if the contract has not been approved by the Office of the State Comptroller.

WORK TO BE DONE

The following is a general description of the work to be done under this Contract. This list is intended to give the Contractor a general description of the work involved in this Contract and is not a complete listing of all work to be done. All work shall be done in accordance with the Contract Documents even though not specifically mentioned in this list.

1. Construct an addition to the existing Weedsport Maintenance Section Building.
 - a. The addition will have an expanded locker room, cafeteria, and restrooms to better accommodate the building's employees.
2. Remove existing roof, perform concrete deck repairs, as may be needed, and replace with a new SBS modified bituminous roof. Replacement of this roof will also involve asbestos abatement and selected structure demolition.
3. Project cleanup and restoring site back to preconstruction conditions.

SCHEDULE AND SUSPENSION OF WORK

The New York State Thruway is a limited access, high-speed, high-volume highway. Traffic shall be maintained in accordance with the *Manual on Uniform Traffic Control Devices (MUTCD)*, the *Work Zone Traffic Control Plans*, the *Standard Specifications* Section 619 and the following provisions:

A. WORK ZONE TRAFFIC CONTROL

1. Lane closures on the Thruway shall only be allowed in accordance with the traffic management table(s), available on the Thruway Authority website at <http://www.thruway.ny.gov/business/contractors/standard-sheets/index.shtml>, unless indicated otherwise in the contract documents. If more than one table is applicable to a work zone location, the most restrictive requirements shall be used. Traffic management tables do not guarantee lane closure availability; the requirements of Section B. *Work Restrictions* shall supersede these tables, when applicable.
2. Lane closures on the Thruway will be permitted for work site access, delivery of materials and equipment, and work operations. Personal vehicles will **NOT** be allowed to park along the Thruway or within lane closures on the Thruway at any time. During non-working hours, all equipment and materials shall be stored at least 30 feet from the edge of pavement (both mainline and ramps) or be protected by a physical barrier approved by the Engineer.
3. Lane closures will **NOT** be permitted during holiday periods or when unforeseen circumstances arise, as described in Section B. *Work Restrictions*, unless indicated otherwise in the contract documents.
4. Lane closures will **NOT** be permitted for the sole convenience of the Contractor. Lane closures will be permitted in order to protect traffic from an actual hazard, as determined by the Engineer.
5. Permanent lane closures will **NOT** be permitted for the duration of the contract.
6. Simultaneous closure of right and left shoulders will **NOT** be permitted unless indicated otherwise in the contract documents. Either right or left shoulder must remain clear and available through all work zones. The open shoulder shall not be used for the storage of vehicles, equipment, supplies or any other obstructions, or for any work activity.
7. Ramp closures will **NOT** be permitted, unless indicated otherwise in the contract documents. Access to interchanges, service areas and parking areas shall be maintained at all times.
8. Traffic will **NOT** be permitted to drive on milled pavement, unless indicated otherwise in the contract documents.

B. WORK RESTRICTIONS

1. **HOLIDAY PERIODS.** Lane closures will **NOT** be permitted during holiday periods, unless indicated otherwise in the contract documents. The Authority may permit work on Thruway facilities only if operations do not inhibit or distract traffic. Access to work sites from state and local roads will be permitted provided the municipality having jurisdiction for the road gives written permission. Holiday periods for this project shall be as follows:

SCHEDULE AND SUSPENSION OF WORK

SYRACUSE DIVISION

2024						
HOLIDAY	FROM			TO		
	TIME	DAY	DATE	TIME	DAY	DATE
Dr. Martin Luther King, Jr. Day	Noon	Friday	01/12/2024	8:00 p.m.	Monday	01/15/2024
Presidents' Day	Noon	Friday	02/16/2024	8:00 p.m.	Monday	02/19/2024
Easter	Noon	Thursday	03/28/2024	8:00 p.m.	Monday	04/01/2024
Memorial Day	Noon	Thursday	05/23/2024	Noon	Tuesday	05/28/2024
Canada Day/Independence Day	Noon	Friday	06/28/2024	Noon	Monday	07/08/2024
State Fair/Labor Day	6:00 a.m.	Thursday	08/22/2024	Noon	Tuesday	09/03/2024
Columbus Day/ Thanksgiving (Canada)	6:00 a.m.	Friday	10/11/2024	Noon	Tuesday	10/15/2024
Thanksgiving	Noon	Tuesday	11/26/2024	Noon	Monday	12/02/2024
Christmas/New Year's Day	Noon	Tuesday	12/24/2024	6:00 a.m.	Thursday	01/02/2025

2. Proposed lane closure schedules shall be submitted to the Engineer for review and approval at least one week in advance of the earliest closure.
3. The Contractor shall **NOT** be allowed to establish any lane closures during periods of inclement weather, wet or icy pavement, reduced visibility, traffic accident, emergency, or if the lane closure is causing excessive delay to the public. The Authority reserves the right to alter any lane closure and/or direct the Contractor to immediately remove a lane closure during such circumstances. The Authority shall be the sole judge of when conditions warrant these lane closure restrictions, and such restrictions will not entitle the Contractor to file a claim for additional compensation.
4. **SYRACUSE STATE FAIR 2024:** Lane closures will **NOT** be permitted from 7:30 a.m. Wednesday, August 21, 2024, through 6:30 a.m. Tuesday, September 3, 2024.
5. **WINTER SHUTDOWN.** A winter shutdown shall be in effect from 3:00 p.m. **November 15** to 6:00 a.m. **April 1**. During this period, the Contractor shall **NOT** be permitted to have lane closures. All temporary tape lines shall be removed, temporary concrete barrier shall be set in its winter shutdown location, and all traffic shall be re-established to its pre-construction configuration on permanent alignment. Mobilization for the following construction season may begin prior to **April 1** with permission from the Authority.
6. The Contractor shall submit a Plan of Operations to the Engineer prior to working on any full-depth repair area shown in the contract documents. The Plan of Operations shall list all full-depth repair areas and the estimated duration to complete each location. The Contractor shall also identify any full-depth repair area that may not be completed within the timeframes allowed by the traffic management table(s). For such location(s), the Contractor may request a waiver of restrictions to complete the repair(s). The Authority will review the request and determine whether or not a waiver will be granted. The Authority has the right to divide repair areas into smaller sections in lieu of granting a waiver.
7. The Contractor shall have 45 calendar days to replace the Milled in Audible Roadway Delineators (MIARDs; Formerly referred to as Shoulder Treatment for Accident Reduction (STAR) groove pattern) where more than 1,500 contiguous feet have been removed by other contract work. The Contractor shall also ensure that MIARDs are installed prior to the official shutdown period, regardless of the 45 calendar day requirement or the length removed. Exceptions to this requirement are shoulders protected by temporary traffic control devices installed as part of a work zone traffic control plan developed in the

SCHEDULE AND SUSPENSION OF WORK

contract documents or areas directly adjacent to detour pavement that will be used in subsequent phase(s) of the project.

The Contractor shall consider these requirements when preparing bids and scheduling/sequencing the work for this contract. Failure to comply with the time frames specified will be considered a substantial deficiency in work zone traffic control and result in the non-payment for the Basic Work Zone Traffic Control Item for each calendar day during which MIARDs (formerly referred to as STARs) remain incomplete. Liquidated Damages will also be assessed at rates shown in Table 108-1 of the NYSDOT Standard Specifications.

8. Work restrictions may be modified if:
- a. The Contractor has received permission through the Engineer, from the Division Director or designee, to progress construction operations contained entirely behind temporary concrete barrier. There shall be no hauling of materials in or out of the work site during restricted periods, and open lane availability requirements shall not be violated or compromised.
 - b. The Contractor has received permission through the Engineer, from the Division Director or designee, for temporary modification of the lane availability restrictions for performance of specific construction operations for a specific time period.

NOTE: Such requests must be based on current traffic volumes which would permit the requested temporary modification with little probability of causing disruption or delay to the public.

The Contractor shall include full explanation of the benefits to the Public and to the Authority, which would accrue in granting a temporary waiver for performance of the specific operations including calculations for any credit that may be offered. A contingency plan for action to be taken, should an unexpected traffic backup occur, shall accompany this presentation and will be one prime consideration in evaluating the request.

- c. The Contractor has received written authorization from the Division Director or designee to perform specific construction operations, violating the lane availability restrictions or other work restrictions during a specifically prohibited time period.

NOTE: The Contractor shall submit a written request to the Authority's Division Director, with copy to the Engineer, for permission to perform specific construction operations at specific locations and times, including a detailed explanation of why the work cannot be performed in conformance with the contract. Such requests must be received at the Division Office at least one full week before the date of the requested variance, and at least two full weeks should granting the waiver require making notice to the public regarding potential disruptions and delays.

If written authorization to work is granted by the Authority, the Contractor shall be strictly limited to those operations approved in the authorization. In making application for a waiver, the Contractor agrees that any waiver of restrictions granted by the Authority is exclusively for the Authority's benefit and purposes, and as such is subject to revocation without requirement for advance notice. Also, the disapproval of requests for waiver of contract requirements is not subject to administrative review or appeal under the contract.

C. GENERAL CONDITIONS

The Contract is to be completed on or before the specified completion date. If, for any reason, the Contractor fails to fulfill this obligation and requests an extension of time and the request is granted, the Authority, as a

SCHEDULE AND SUSPENSION OF WORK

condition for extending the time of completion, shall retain the right to limit the Contractor's hours and/or days of work and/or impose conditions under which the work shall be performed in order that the traffic may not be unduly inconvenienced.

All the required liability and property damage insurance with the limits stated in this Proposal shall be effective and shall be continued in force throughout the life of this Contract including the stated periods of the suspension of the work.

The Contractor shall consider the foregoing requirement when preparing its "Schedule of Operations".

ADDITIONAL INSURED PARTIES

The following is a list of additional insured parties:

- Village of Weedsport
- NYS Department of Transportation

NON-REVENUE CONTRACTOR TRAVEL

NYS Thruway has converted to Cashless Tolling, Non-revenue pass plates will no longer be furnished to the Contractor.

Contractors and Consultants must have a properly mounted E-Z Pass transponder and must submit their EZ-Pass information to the Thruway to avoid charges for contract related business on the Thruway. The Project Engineer will provide the form used to record and submit EZ Pass information. Initial information shall be submitted to the Project Engineer prior to the start of work on the project. The initial form and any changes shall be submitted 5 working days prior to intended travel.

The Contractor shall be responsible for any and all tolls charged to contractor owned vehicles with (or without) E-ZPass Transponders not registered with the Authority.

OTHER CONTRACTS

The Contractor will be required to coordinate work with other contractors and NYSTA maintenance forces. The following contracts have been let and may have work in progress during the duration of this contract:

<u>CONTRACT NO.</u>	<u>DESCRIPTION</u>	<u>COMPLETION DATE</u>
TAS 22-27B, D214895	Warners Road over Thruway, Replacement, MP 292.49	October 31, 2024
TAS 23-26B, D214943	Syracuse Division On-Demand Repairs	December 31, 2025

U-TURNS/CROSSOVERS

The Contractor will not be permitted to make U-turns or crossovers at any location on the Thruway system. All vehicles must exit the Thruway system and re-enter for all direction changes. All applicable traffic laws must be followed.

ENGINEER'S OFFICE AND CONTRACTOR'S FIELD OFFICE

The location of the Engineer's Office and Contractor's Field Office shall be determined during the Pre-Construction Meeting. The site shall be approved by the Engineer prior to placing the offices and the area shall be kept in a neat, clean condition at all times. The area shall not be used as a staging, storage, equipment or employee parking area.

SPOIL AREA

There is no identified spoil area within the Thruway Authority's right-of-way for this contract. Therefore, the Contractor shall remove all surplus material and waste from Thruway Authority (Authority) property. The Contractor shall bid accordingly for this condition.

The Contractor shall provide the Authority a copy of all easements and/or access agreement letters received from landowner(s) of off-site disposal area(s) prior to disposal of any material. The easements and/or access agreement letters must include a statement by the Contractor and the landowner that the disposal of the material is in compliance with all applicable federal, state and local laws and regulations.

Should a mutually approved spoil use area within the Authority's right-of-way be identified for Contractor use after the project letting, a credit in the amount of 50% of the unclassified excavation unit bid price will be deducted for each cubic yard spoiled within the Authority right-of-way. If the contract does not contain an unclassified excavation item, the credit will be determined using either 50% of the item generating the spoil or 50% of the Division/Regional weighted average bid price for unclassified excavation, whichever is less. This credit may be waived, either wholly or in part, by the Division Director in writing if it is determined that permitting spoil on Authority right-of-way is in the best interest of the Authority (ie: slope flattening resulting in elimination of guide rail).

OVERHEAD GANTRY**SIGNING**

Signs shall be installed within the project limits when any component of equipment will be operating above 14'-6" in elevation and within 100 linear feet of an overhead gantry. Overhead gantries may have electric powered wires and special equipment, therefore, vehicle and equipment operations must be planned and proposed equipment safety procedures included in a Project Safety and Health Plan.

As mentioned in the Thruway Addendum to the Standard Specifications (TA), specifically in **Section 107-05 SAFETY AND HEALTH REQUIREMENTS, O. Equipment Safety Procedures. 6. Work Operations. d.** Dump truck boxes may be raised only under the control of a spotter, unless the vehicle is in an area clearly marked to be free of overhead wires and safe for dumping.

Refer to Thruway Standard Sheet **TA 619-27** for additional information and signing requirements.

OVERHEAD GANTRY**TRAFFIC SHIFT RESTRICTIONS**

The Contractor shall not shift traffic at any toll gantry such that vehicles are traveling between lanes or between lanes/shoulders when passing under the gantry centerline (treadle). Traffic shifts, for purposes of staging work, shall be done prior to or after the gantries, such that vehicles are traveling within a complete lane or shoulder when passing under the gantry centerline (treadle). All work zone traffic control shall be provided in accordance with the 619 Standard Specifications and the Thruway Addendum to the 619 Standard Specifications, the National Manual on Uniform Traffic Control Devices and NYS Supplement, any provisions contained within the contract documents, and as ordered by the Engineer.

SUPPLEMENTAL INFORMATION FOR BIDDERS

Supplemental information is available to bidders. As indicated below, information is either available on the Thruway Authority's website with the contract plans and proposal or available in electronic format from the Thruway Authority upon request prior to or after the letting date.

The bidder's signature on this proposal certifies that they have made themselves aware of the availability of the information indicated below prior to the letting date.

INFORMATION	NOT AVAILABLE	AVAILABLE ON THRUWAY AUTHORITY WEBSITE
Engineer Estimate Quantity Workups	X	
Utility Estimate Sheets with Names of Utility Officials	X	
Earthwork Cross Section Sheets	X	
Earthwork Sheets	X	
Drainage Estimate Sheets	X	
Sign Face Layouts	X	
Subsurface Exploration Logs	X	
Rock Core Evaluation Logs and Photographs	X	
Compression Test Data from Rock Samples	X	
Pavement Core Logs and Photographs	X	
Logs Showing Laboratory Description of Soil Samples	X	
Laboratory Test Data from Soil Samples	X	
Rock Outcrop Maps	X	
Record Plans	X	
Applicable Asbestos Blanket Variances	X	
Storm Water Pollution Prevention Plan	X	
Shop Drawings	X	
CADD Files of Contract Plans (Unofficial - Not signed or stamped)	X	
Special Reports of other Information (Fox Blocks Technical Info and Training Guide)		X

Hard copies of the supplemental information indicated above are not available. Contractors shall be responsible for their own hard copies of this information at no additional cost to the Authority.

**REVISIONS TO
NYSDOT
STANDARD
SPECIFICATIONS**

NEW YORK STATE THRUWAY AUTHORITY ADDENDUM TO THE STANDARD SPECIFICATIONS

The Standard Specifications published by the New York State Department of Transportation shall form a part of the agreement. The dated edition that applies to this contract is provided on the front cover of the Proposal. All work contemplated under this contract is to be covered by, and be in conformance with, the Standard Specifications as modified by The New York State Thruway Authority Addendum (TA) to the Standard Specification Books.

The officially adopted Thruway Authority Addendum (TA) to the NYSDOT Standard Specification Books is available on the Thruway Authority website at:

<http://www.thruway.ny.gov/business/addendum/index.html>

The most recent version of the TA, prior to the project Letting Date, shall apply to this agreement.

All special notes bound in this proposal shall be incorporated. If a conflict exists between the special specifications and/or provisions set forth in this proposal and the specifications and/or provisions set forth in the New York State Department of Transportation's Standard Specifications, those in the Proposal shall govern.

SPECIAL SPECIFICATIONS

SPECIAL NOTE
SPECIAL SPECIFICATION PAY ITEM NUMBERS

The Contractor's attention is directed to the special specification pay item formats used in this contract. Special specification pay items may be presented in two (2) different formats:

Format 1: Pay items for a special specification will have three (3) digits to the left of the decimal point and up to eight (8) digits to the right of the decimal. Spaces may appear in the third to sixth places after the decimal. The 7th and 8th digits to the right of the decimal will represent the origin of the specification.

Format 2: Pay items for a special specification will have three (3) digits to the left of the decimal point and up to eight (8) digits to the right of the decimal. Dashes may appear in the third to sixth places after the decimal. The 7th and 8th digits to the right of the decimal will represent the origin of the specification.

Where items in this contract appear in multiple formats, the formats shall be equated to each other as illustrated below:

FORMAT 1
 XXX.XX XX
 XXX.XXXX XX
 XXX.XXXXXXXXX

FORMAT 2
 XXX.XX-----XX
 XXX.XXXX---XX
 XXX.XXXXXXXXX

ITEM 627.0001 25**GENERAL REQUIREMENTS****1. DESCRIPTION:**

- 1.01 Furnish all labor, materials, equipment, and services necessary to complete the work as indicated on the Contract Plans and the attached Specification Summary.
- 1.02 All work shall conform to the requirements specified in Part 1 – General, of the Sections listed.

2. MATERIALS:

- 2.01 The materials shall be as specified in Part 2 – Products, of the Sections listed.

3. CONSTRUCTION DETAILS:

- 3.01 The construction details shall be as specified on Part 3 – Execution, of the Sections listed.

4. METHOD OF MEASUREMENT:

- 4.01 This item shall be measured for payment on a lump sum basis for the work completed in accordance with the Contract Documents and as directed by the Engineer.

5. BASIS OF PAYMENT:

- 5.01 Payment for this item shall be made at the lump sum bid price bid. The lump sum price bid shall include cost of furnishing all labor, material, equipment and appliances necessary to complete the work as indicated on the Contract Plans and as specified herein in the Sections listed.
- 5.02 Detailed Estimate:
 - A. Before the first certificate of payment is issued for the work under this item, submit a detailed estimate of quantities and prices for all materials, labor, and other items included under this item, which shall aggregate the contract lump sum price bid for this item. Prepare the detailed estimate in the same sequence as the Sections listed.
 - B. The detailed estimate shall be supported by such evidence, including certified copies of subcontracts, as the Engineer may require.
 - C. The detailed estimate must be approved by the Engineer who may revise it as, in his/her reasonable judgment, is necessary to make the various items conform to their true values. The value of each certificate of payment will be based on the approved detailed estimate.
- 5.03 Monthly payments will be made for this item in proportion to the total amount of work completed.

ITEM 627.0001 25**GENERAL REQUIREMENTS****1. SPECIFICATION SUMMARY**

1.01 This Item includes the following specifications:

- A. Section 003126 EXISTING HAZARDOUS MATERIAL INFORMATION
- B. Section 010000 GENERAL NOTES
- C. Section 011000 SUMMARY OF THE WORK
- D. Section 015000 TEMPORARY FACILITIES AND CONTROLS

1.02 This item shall include, but not be limited to, the following:

- A. Information on hazardous materials such as ACM, as well as a reference to supplemental information. This information is listed in Section 003126 – HAZARDOUS MATERIAL INFORMATION.
- B. Requirements not found in the Standard Specification but an integral part of most building related construction projects. These requirements are listed in Section 010000 – GENERAL NOTES.
- C. Description of the work included. Sequencing, special timing provisions, unique project concerns and the completion date will be addressed as required in Section 011000 SUMMARY OF THE WORK.
- D. Requirements for electrical supply, water supply, temporary heat, shelter, sanitary facilities, lighting, etc. will be addressed as required in Section 015000 – TEMPORARY FACILITIES AND CONTROLS.

1.03 Items specifically not paid for under this item shall include, but not be limited to, the following:

- A. Not Used

SECTION 003126 - EXISTING HAZARDOUS MATERIAL INFORMATION

1.1 EXISTING HAZARDOUS MATERIAL INFORMATION

- A. This Section with its referenced attachments is part of the Procurement and Contracting Requirements for Project. They provide Owner's information for Contractors' convenience and are intended to supplement rather than serve in lieu of Contractors' own investigations and are not a warranty of existing conditions.
- B. An existing asbestos containing materials report for Project prepared by CORE Environmental Consultants, titled "Inspection for Asbestos-Containing Materials (Scope Asbestos Report) performed at Weedsport Maintenance Section", dated August 08, 2022, is appended to this Document.

END OF SECTION 003126



22-48 119th Street, College Point, NY 11356 ♦ Phone: 718.786.4730 ♦ Fax: 718.786.4764

INSPECTION FOR ASBESTOS-CONTAINING MATERIALS (SCOPE ASBESTOS REPORT)

Performed at:

**WEEDSPORT MAINTENANCE SECTION
NYS THRUWAY EXIT 40
WEEDSPORT, NY 13166**

Performed for:



**NEW YORK STATE THRUWAY AUTHORITY
SYRACUSE DIVISION
290 ELWOOD DAVIS ROAD, SUITE 250 2ND FLOOR
LIVERPOOL, NEW YORK 13088**

Associated With The:

**MAINTENANCE SECTION BUILDING ADDITION AND ROOF REPLACEMENT
NYSTA CONTRACT D214797**

Prepared by:

**CORE ENVIRONMENTAL CONSULTANT, INC.
22-48 119TH STREET
COLLEGE POINT, NY 11356**

AUGUST 08, 2022

REVISED: 1



NEW YORK STATE THRUWAY AUTHORITY – SYRACUSE DIVISION
MAINTENANCE SECTION BUILDING ADDITION AND ROOF REPLACEMENT

TABLE OF CONTENTS

1.0	BACKGROUND	1
2.0	SCOPE OF WORK	2
3.0	PREVIOUS REPORTS	3
4.0	SUMMARY OF INSPECTION RESULTS	4
4.1	Summary of Inspection Results Table (SIRT)	5
5.0	CONCLUSIONS AND RECOMMENDATIONS	9
6.0	ASBESTOS QUANTITY SCHEDULE	10
7.0	ASBESTOS ABATEMENT COST ESTIMATES	11
8.0	REPORT CERTIFICATIONS	17

APPENDICES

APPENDIX A:	Analytical Results, Chain of Custody Documentation, & Certificates of Analysis
APPENDIX B:	Company & Personnel Licenses
APPENDIX C:	Laboratory Accreditations
APPENDIX D:	Bulk Sample location drawings
APPENDIX E:	Previous Reports



NEW YORK STATE THRUWAY AUTHORITY – SYRACUSE DIVISION
MAINTENANCE SECTION BUILDING ADDITION AND ROOF REPLACEMENT

1.0 BACKGROUND

CORE Environmental Consultants, Inc. (CORE) has conducted an asbestos survey for the presence of asbestos containing materials (ACM) at the following facility:

Facility: Weedsport Maintenance Section
 Town: Weedsport
 Address: New York State Thruway Exit 40, Weedsport, NY 13166
 Contact: Jeff Blazey
 Phone #: (315) 952-2179

The Investigators and Inspectors responsible for this project were:

Manuel Duran	NYSDOL Inspector # 09-10896	Exp. 07/2022
Joseph Zaheer	NYSDOL Inspector # 21-16549	Exp. 05/2023
Ronald Tramposch	NYCDEP Investigator # 132112	Exp. 07/2023
Site Visit(s):	April 15, 2022; July 13, 2022	
Final Design Submission Report:	August 08, 2022	
Revision:	1	

Field Procedures and Analysis Methodology:

Guidelines used for the inspection were established by the Environmental Protection Agency (EPA) in the Guidance for Controlling Asbestos Containing Materials in Buildings, Office of Pesticides and Toxic Substances, DOC #560/5-85-024, and 40 CFR Part 763, Asbestos Hazard Emergency Response Act (AHERA).

Field information was organized as per the AHERA concept of homogenous area (HA). That is, suspect ACM with similar age, appearance, and texture was grouped together, sampled and assessed for condition.

Bulk samples of suspect ACM were analyzed by Polarized Light Microscopy (PLM) with dispersion staining, as described in 40 CFR Part 763 and the National Emissions Standard for Hazardous Air Pollutants (NESHAPS).

The New York State Department of Health has recently revised the PLM Stratified Point Counting Method. The new method, "Polarized Light Microscopy Methods for Identifying and Quantitating Asbestos in Bulk Samples" can be found as item 198.1 in the ELAP Certification



NEW YORK STATE THRUWAY AUTHORITY – SYRACUSE DIVISION
MAINTENANCE SECTION BUILDING ADDITION AND ROOF REPLACEMENT

manual.

The State of New York ELAP has determined that analysis of non-friable organically bound materials (NOB's) is not reliably performed by PLM. Therefore, if PLM yields negative results for a non-friable material, it must be confirmed by Transmission Electron Microscopy (TEM).

All samples were initially analyzed by Polarized Light Microscopy. Samples which yielded a negative PLM result and which are classified as a "non-friable" organically bound material were then re-analyzed utilizing Transmission Electron Microscopy (TEM) methodology. As per the April 1, 2011 ELAP directive, Item Numbers 198.6/198.4, ceiling tiles with cellulose must now also be confirmed non-ACM via TEM analysis.

In addition, all Thermal system insulation (TSI), surfacing material, or other presumed ACM (PACM) has been analyzed for vermiculite in accordance with the July 9, 2013 New York State Department of Health guidance document.

Laboratory analysis was performed by Laboratory Testing Services, Inc. (LTS) located at 4509 Greenpoint Avenue, Long Island City, NY 11104. LTS's National Voluntary Laboratory Accreditation Program (NVLAP) accreditation number is 101958-0 and their New York State Environmental Laboratory Approval Program (ELAP) number is 10955.



NEW YORK STATE THRUWAY AUTHORITY – SYRACUSE DIVISION
MAINTENANCE SECTION BUILDING ADDITION AND ROOF REPLACEMENT

2.0 SCOPE OF WORK

The areas inspected for asbestos-containing materials (ACM) and which will be impacted by the maintenance section building addition and roof replacement project D214797 Phasing plan drawings dated April, 2022 provided to CORE by CPL Team:

1. Men's Locker Room/Bathroom
2. Women's Locker Room/Bathroom
3. Kitchen/Break Room
4. Mechanical Room
5. Exterior
6. Foyer/Hallway
7. South East Lower Roof
8. Upper Roof
9. North West Lower Roof

The inspection was characterized by a close visual inspection of all accessible areas. Suspect materials found were sampled and inventoried for quantity, condition, and friability.

Materials examined included:

- Suspect miscellaneous materials associated with the scope of work.



NEW YORK STATE THRUWAY AUTHORITY – SYRACUSE DIVISION
MAINTENANCE SECTION BUILDING ADDITION AND ROOF REPLACEMENT

3.0 PREVIOUS REPORTS

NA / Not Applicable



NEW YORK STATE THRUWAY AUTHORITY – SYRACUSE DIVISION
 MAINTENANCE SECTION BUILDING ADDITION AND ROOF REPLACEMENT

4.0 SUMMARY OF INSPECTION RESULTS

The asbestos inspection involved a thorough visual examination of all areas and/or sampling of suspect materials.

Laboratory analysis confirmed the presence of asbestos in the amount **greater than 1%** in the samples collected from the following materials **[ACM]**:

1. Caulking Around Exterior Windows
2. Exterior Duct Seal
3. Caulking Around Edge of Roof

Laboratory analysis determined the samples collected from the following materials to contain **less than 1%** asbestos **[Non-ACM]**:

1. Exterior- Brick Mortar
2. Exterior- Brick Mortar Patch
3. Exterior- Gasket
4. Kitchen- Soft Concrete Underneath Beige Floor Tile
5. Kitchen- 12" x 12" Beige Floor Tile Grout and Backing
6. Kitchen- 2' x 4' Drop Ceiling Tile
7. Kitchen- Black Cove Base Mastic
8. Kitchen- Black Cove Base
9. Kitchen- Green Cove Base Mastic
10. Kitchen- Green Cove Base
11. Kitchen- Window Caulking
12. Men's Locker Room/ Bathroom- Caulking Around Sink
13. Men's Locker Room/ Bathroom- 4" x 4" White Wall Tile Mastic
14. Men's Locker Room/ Bathroom- 4" x 4" White Wall Tile Grout
15. Men's Locker Room/ Bathroom- Grey Ceiling Plaster
16. Men's Locker Room/ Bathroom- White Ceiling Plaster
17. Men's Locker Room/ Bathroom- Gypsum Board (Sheetrock)
18. Men's Locker Room/ Bathroom- Tape Associated with Gypsum Board
19. Men's Locker Room/ Bathroom- Joint Compound Associated with Gypsum Board
20. Mechanical Room- Fiberglass Jacket Around Pipe Insulation
21. Women's Locker Room/ Bathroom- 2' x 4' Drop Ceiling Tile Above Drop Ceiling Tile
22. Women's Locker Room/ Bathroom- Black Cove Base Mastic
23. Women's Locker Room/ Bathroom- Black Cove Base
24. Roof- Caulking Around Edge of Roof
25. Roof- Vapor Barrier
26. Roof- Tar Roof Material
27. Roof- Screed
28. Roof- Tar Roof Material
29. Roof- Caulking on Roof
30. Roof- Tar on Metal Flashing
31. Metal Trim Glue



NEW YORK STATE THRUWAY AUTHORITY – SYRACUSE DIVISION
MAINTENANCE SECTION BUILDING ADDITION AND ROOF REPLACEMENT

32. Bolt Caulk
33. Conduit Glue
34. Pitch Pocket Tar

The following materials were Presumed ACM:

1. Upper and North West Lower Roof- Caulking Around Edge of Roof

Based on uniformity and appearance, and the results of previous testing of the South East Lower Roof from the investigation completed on April 15, 2022, the caulking around the edge of the entirety of the roof is to be presumed positive for asbestos.

The following materials were Non-Suspect:

1. Metal Windows
2. Metal Vent
3. Metal Lockers
4. CMU Walls
5. Foam Insulation
6. Concrete Floor
7. Metal Pipes
8. Rubber Wires
9. Metal HVAC System
10. Metal conduits with Rubber Wires
11. Rubber Roof
12. Foam insulation under rubber roof
13. Metal Edge Cap
14. Rubber wires in panel
15. Rubber wires in Junction Boxes
16. Metal Built-in Ladder



NEW YORK STATE THRUWAY AUTHORITY – SYRACUSE DIVISION
 MAINTENANCE SECTION BUILDING ADDITION AND ROOF REPLACEMENT

4.1 SUMMARY OF INSPECTION RESULTS TABLE (SIRT)

New York State Thruway Authority Buffalo Division 455 Cayuga Road, Suite 800, Cheektowaga, New York 14425 Maintenance Section Building Addition and Roof Replacement Contract D214797 – Weedsport Thruway Section									
Proposed Work	HA #	Location	Material	No. of Samples	Results	PLM	PLM NOB	TEM NOB	Notes
<u>Maintenance Section Building Addition and Roof Replacement</u>	A.	Exterior	Brick Mortar	2	Non-ACM	-			
	B.		Caulking Around Windows	2	ACM		TR	2.18%	Chrysotile
	C.		Brick Mortar Patch	2	Non-ACM	-			
	D.		Gasket	2	Non-ACM		-	-	
	E.		Duct Seal	2	ACM		26.17%	N/A	Chrysotile



NEW YORK STATE THRUWAY AUTHORITY – SYRACUSE DIVISION
 MAINTENANCE SECTION BUILDING ADDITION AND ROOF REPLACEMENT

New York State Thruway Authority Buffalo Division
455 Cayuga Road, Suite 800, Cheektowaga, New York 14425

Maintenance Section Building Addition and Roof Replacement Contract D214797 – Weedsport Thruway Section

Proposed Work	HA #	Location	Material	No. of Samples	Results	PLM	PLM NOB	TEM NOB	Notes
<u>Maintenance Section Building Addition and Roof Replacement</u>	F.	Kitchen/ Break Room	Soft Concrete Underneath 12" x 12" Beige Floor Tile	2	Non-ACM	-			
	G.		12" x 12" Beige Floor Tile Grout and Backing	2	Non-ACM	-			
	H.	Men's Locker Room/ Bathroom	2' x 4' Drop Ceiling Tile	2	Non-ACM		-	-	
	I.		Black Cove Base Mastic	2	Non-ACM		-	-	
	J.		Black Cove Base	2	Non-ACM		-	-	
	K.		Green Cove Base Mastic	2	Non-ACM		-	-	
	L.		Green Cove Base	2	Non-ACM		-	-	
	M.		Window Caulking	2	Non-ACM		-	-	



NEW YORK STATE THRUWAY AUTHORITY – SYRACUSE DIVISION
 MAINTENANCE SECTION BUILDING ADDITION AND ROOF REPLACEMENT

New York State Thruway Authority Buffalo Division
455 Cayuga Road, Suite 800, Cheektowaga, New York 14425

Maintenance Section Building Addition and Roof Replacement Contract D214797 – Weedsport Thruway Section

Proposed Work	HA #	Location	Material	No. of Samples	Results	PLM	PLM NOB	TEM NOB	Notes
<u>Maintenance Section Building Addition and Roof Replacement</u>	N.	Men's Locker Room/ Bathroom	Caulking Around Sink	2	Non-ACM		-	-	
	O.		4" x 4" White Wall Tile Mastic	2	Non-ACM		-	-	
	P.		4" x 4" White Wall Tile Grout	2	Non-ACM	-			
	Q.		Ceiling Plaster - Grey	3	Non-ACM	-	-		
	R.		Ceiling Plaster – White	3	Non-ACM	-	-		
	S.		Gypsum Board (Sheetrock)	2	Non-ACM	-			
	T.		Tape Associated with Gypsum Board	2	Non-ACM	-			
	U.		Joint Compound Associated with Gypsum Board	2	Non-ACM	-			



NEW YORK STATE THRUWAY AUTHORITY – SYRACUSE DIVISION
 MAINTENANCE SECTION BUILDING ADDITION AND ROOF REPLACEMENT

<p align="center">New York State Thruway Authority Buffalo Division 455 Cayuga Road, Suite 800, Cheektowaga, New York 14425</p> <p align="center">Maintenance Section Building Addition and Roof Replacement Contract D214797 – Weedsport Thruway Section</p>									
Proposed Work	HA #	Location	Material	No. of Samples	Results	PLM	PLM NOB	TEM NOB	Notes
<u>Maintenance Section Building Addition and Roof Replacement</u>	V.	Mechanical Room	Fiberglass Jacket Around Pipe Insulation	3	Non-ACM	-			
<u>Maintenance Section Building Addition and Roof Replacement</u>	W.	Women's Locker Room/ Bathroom	2' x 4' Drop Ceiling Tile Above Drop Ceiling Tile	2	Non-ACM		-	-	
	X.		Black Cove Base Mastic	2	Non-ACM		-	-	
	Y.		Black Cove Base	2	Non-ACM		-	-	



NEW YORK STATE THRUWAY AUTHORITY – SYRACUSE DIVISION
 MAINTENANCE SECTION BUILDING ADDITION AND ROOF REPLACEMENT

New York State Thruway Authority Buffalo Division
455 Cayuga Road, Suite 800, Cheektowaga, New York 14425

Maintenance Section Building Addition and Roof Replacement Contract D214797 – Weedsport Thruway Section

Proposed Work	HA #	Location	Material	No. of Samples	Results	PLM	PLM NOB	TEM NOB	Notes
<u>Maintenance Section Building Addition and Roof Replacement</u>	Z.	South East Lower Roof	Caulking Around Edge of Roof	2	ACM		9.95%	N/A	Chrysotile
	AA.		Vapor Barrier	2	Non-ACM		-	-	
	AB.		Tar Roof Material	2	Non-ACM		-	-	
	AC.		Screed	2	Non-ACM	-			
	AD.		Tar Roof Material	2	Non-ACM		-	-	
	AE.		Caulking on Roof	2	Non-ACM		-	-	
	AF.		Tar on Metal Flashing	2	Non-ACM		-	-	



NEW YORK STATE THRUWAY AUTHORITY – SYRACUSE DIVISION
 MAINTENANCE SECTION BUILDING ADDITION AND ROOF REPLACEMENT

New York State Thruway Authority Buffalo Division
455 Cayuga Road, Suite 800, Cheektowaga, New York 14425

Maintenance Section Building Addition and Roof Replacement Contract D214797 – Weedsport Thruway Section

Proposed Work	HA #	Location	Material	No. of Samples	Results	PLM	PLM NOB	TEM NOB	Notes
<u>Maintenance Section Building Addition and Roof Replacement</u>	A.	Upper Roof	Top (4 th) Layer Felt Paper	5	Non-ACM		-	-	
	B.		3 rd Layer Felt Paper	5	Non-ACM		-	-	
	C.		Top (3 rd) Layer Screed	5	Non-ACM	-			
	D.		2 nd Layer Felt Paper	5	Non-ACM		-	-	
	E.		2 nd Layer Screed	5	Non-ACM	-			
	F.		Bottom (1 st) Layer Felt Paper	5	Non-ACM		-	-	
	G.		Bottom (1 st) Layer Screed	5	Non-ACM	-			
	H.		Tar Roof Material	5	Non-ACM		-	-	



NEW YORK STATE THRUWAY AUTHORITY – SYRACUSE DIVISION
 MAINTENANCE SECTION BUILDING ADDITION AND ROOF REPLACEMENT

New York State Thruway Authority Buffalo Division
455 Cayuga Road, Suite 800, Cheektowaga, New York 14425

Maintenance Section Building Addition and Roof Replacement Contract D214797 – Weedsport Thruway Section

Proposed Work	HA #	Location	Material	No. of Samples	Results	PLM	PLM NOB	TEM NOB	Notes
	I.	Upper Roof	Roof Caulking	2	Non-ACM		-	-	
	J.		Edge Caulking	2	Non-ACM		-	-	
	K.		Pitch Pocket Tar	2	Non-ACM		-	-	
<u>Maintenance Section Building Addition and Roof Replacement</u>	L.	North West Lower Roof	Top Layer Felt Paper	2	Non-ACM		-	-	
	M.		Bottom Layer Felt Paper	2	Non-ACM		-	-	
	N.		Screed	2	Non-ACM	-			
	O.		Tar Roof Material	2	Non-ACM		-	-	
	P.		Metal Trim Glue	2	Non-ACM		-	-	



NEW YORK STATE THRUWAY AUTHORITY – SYRACUSE DIVISION
 MAINTENANCE SECTION BUILDING ADDITION AND ROOF REPLACEMENT

**New York State Thruway Authority Buffalo Division
 455 Cayuga Road, Suite 800, Cheektowaga, New York 14425**

Maintenance Section Building Addition and Roof Replacement Contract D214797 – Weedsport Thruway Section

Proposed Work	HA #	Location	Material	No. of Samples	Results	PLM	PLM NOB	TEM NOB	Notes
	Q.	North West Lower Roof	Bolt Caulk	2	Non-ACM		-	-	
	R.		Conduit Glue	2	Non-ACM		-	-	
	S.		Roof Caulking	2	Non-ACM		-	-	
	T.		Pitch Pocket Tar	2	Non-ACM		-	-	

NOTE: ACM – Asbestos-Containing Material; PACM – Presumed Asbestos-Containing Material



5.0 CONCLUSIONS AND RECOMMENDATIONS

This inspection was conducted solely for the proposed New York State thruway Authority Buffalo Division of the maintenance section building addition and roof replacement project at the Weedsport Maintenance Section located in Weedsport, New York. If the proposed work should change, additional inspection work may be necessary prior to any commencement of proposed work. In the event that the scope of work changes or any ACM is found that is to be disturbed by the proposed renovation work, the following recommendations are proposed by CORE Environmental Consultants, Inc. to ensure that the removal of the ACM is properly and effectively carried out:

- A. Develop and implement a schedule that outlines the time frame for removal of asbestos-containing materials.
- B. Develop complete and concise specifications to effectively deal with removal of the asbestos-containing material. These specifications should be developed to comply with all applicable federal, state, and local regulations.
- C. Retain the service of an independent testing firm and laboratory to monitor the quality of the air before, during, and after the removal work. Retain all documentation and correspondence from the removal contractor, the testing laboratory, and related items in a permanent record.



NEW YORK STATE THRUWAY AUTHORITY – SYRACUSE DIVISION
MAINTENANCE SECTION BUILDING ADDITION AND ROOF REPLACEMENT

6.0 ASBESTOS QUANTITY SCHEDULE

To be provided during final design stage

NA / Not Applicable



NEW YORK STATE THRUWAY AUTHORITY – SYRACUSE DIVISION
MAINTENANCE SECTION BUILDING ADDITION AND ROOF REPLACEMENT

7.0 PRELIMINARY ASBESTOS ABATEMENT COST ESTIMATE

To be provided during final design stage

NA / Not Applicable



NEW YORK STATE THRUWAY AUTHORITY – SYRACUSE DIVISION
 MAINTENANCE SECTION BUILDING ADDITION AND ROOF REPLACEMENT

8.0 REPORT CERTIFICATIONS

CORE Environmental Consultants, Inc. (CORE) certifies that the information contained herein is based on the physical and visual inspections conducted by CORE and data collected during the inspection survey.

Manuel Duran
 NYSDOL Asbestos Inspector
 Project Manager

Ronald Tramposch
 NYSDOL Asbestos Investigator
 QA/QC Senior Project Manager

Joseph Zaheer
 NYSDOL Asbestos Inspector



APPENDIX A

Analytical Results, Chain of Custody Documentation, &
Certificates of Analysis



APPENDIX B

Company and Personnel Licenses



APPENDIX C

Laboratory Accreditations



NEW YORK STATE THRUWAY AUTHORITY – SYRACUSE DIVISION
MAINTENANCE SECTION BUILDING ADDITION AND ROOF REPLACEMENT

APPENDIX D

Bulk Sample Location Drawings

August 08, 2022





APPENDIX E

Previous Reports

NA / Not Applicable



APPENDIX A

Analytical Results, Chain of Custody Documentation, &
Certificates of Analysis

BULK ASBESTOS TEST REPORT

Client/Address: Core Environmental / 22-48 119th St., College Point, NY 11356					Project: Weedsport Thruway Station								
Laboratory ID: 22-05-008			Date of Report: 05/04/22			Date of Analysis: 05/03/22							
Client ID # Lab ID #	Stereomicroscope Analysis			Sample Description	% Non-Fibrous Material	% Friable Results		% AII	% PLM NOB Results		% TEM NOB Results		% TOTAL Asbestos
	A	BR	E										
04.15.2022-01 22-05-008-01	A	BR	E	Exterior, Brick Mortar	100.00	NAD							NAD
	B	1	F										
	C	198.1	G										
	D		H										
04.15.2022-02 22-05-008-02	A	BR	E	Exterior, Brick Mortar	100.00	NAD							NAD
	B	1	F										
	C	198.1	G										
	D		H										
04.15.2022-03 22-05-008-03	A	GR	E	Exterior, Caulking Around Windows				7.25	TRACE	CH	2.18	CH	2.18
	B	1	F										
	C	198.4/6	G										
	D		H										
04.15.2022-04 22-05-008-04	A	GR	E	Exterior, Caulking Around Windows				6.93	NAD		NA		SAFP
	B	1	F										
	C	198.6	G										
	D		H										
04.15.2022-05 22-05-008-05	A	BR	E	Exterior, Brick Mortar Patch	100.00	NAD							NAD
	B	1	F										
	C	198.1	G										
	D		H										
04.15.2022-06 22-05-008-06	A	BR	E	Exterior, Brick Mortar Patch	100.00	NAD							NAD
	B	1	F										
	C	198.1	G										
	D		H										

BULK ASBESTOS TEST REPORT

Client/Address: Core Environmental / 22-48 119th St., College Point, NY 11356					Project: Weedsport Thruway Station								
Laboratory ID: 22-05-008			Date of Report: 05/04/22		Date of Analysis: 05/03/22								
Client ID # Lab ID #	Stereomicroscope Analysis			Sample Description	% Non-Fibrous Material	% Friable Results		% AII	% PLM NOB Results		% TEM NOB Results		% TOTAL Asbestos
	A	GR	E										
04.15.2022-07 22-05-008-07	A	GR	E	Exterior, Gasket				0.32		NAD		NAD	NAD
	B	I	F										
	C	198.4/6	G										
	D		H										
04.15.2022-08 22-05-008-08	A	GR	E	Exterior, Gasket				0.42		NAD		NAD	NAD
	B	I	F										
	C	198.4/6	G										
	D		H										
04.15.2022-09 22-05-008-09	A	GR	E	Exterior, Duct Seal				52.33		26.17	CH	NA	26.17
	B	I	F										
	C	198.6	G										
	D		H										
04.15.2022-10 22-05-008-10	A	GR	E	Exterior, Duct Seal				53.61		NA		NA	SAFP
	B	I	F										
	C		G										
	D		H										
04.15.2022-11 22-05-008-11	A	GR	E	Kitchen/Break Room, Soft Concrete Underneath 12" x 12" Beige Floor Tile	100.00					NAD			NAD
	B	I	F										
	C	198.1	G										
	D		H										
04.15.2022-12 22-05-008-12	A	GR	E	Kitchen/Break Room, Soft Concrete Underneath 12" x 12" Beige Floor Tile	100.00					NAD			NAD
	B	I	F										
	C	198.1	G										
	D		H										

BULK ASBESTOS TEST REPORT

Client/Address: Core Environmental / 22-48 119th St., College Point, NY 11356					Project: Weedsport Thruway Station								
Laboratory ID: 22-05-008			Date of Report: 05/04/22			Date of Analysis: 05/03/22							
Client ID # Lab ID #	Stereomicroscope Analysis			Sample Description	% Non-Fibrous Material	% Friable Results		% AII	% PLM NOB Results		% TEM NOB Results		% TOTAL Asbestos
04.15.2022-13 22-05-008-13	A	BR	E	Kitchen/Break Room, 12" x 12" Beige Floor Tile Grout And Backing	100.00	NAD							NAD
	B	I	F										
	C	198.1	G										
	D		H										
04.15.2022-14 22-05-008-14	A	BR	E	Kitchen/Break Room, 12" x 12" Beige Floor Tile Grout And Backing	100.00	NAD							NAD
	B	I	F										
	C	198.1	G										
	D		H										
04.15.2022-15 22-05-008-15	A	WH	E	Kitchen/Break Room, 2' x 4' Drop Ceiling Tile				51.36	NAD		NAD		NAD
	B	I	F										
	C	198.4/6	G										
	D		H										
04.15.2022-16 22-05-008-16	A	WH	E	Kitchen/Break Room, 2' x 4' Drop Ceiling Tile				56.41	NAD		NAD		NAD
	B	I	F										
	C	198.4/6	G										
	D		H										
04.15.2022-17 22-05-008-17	A	WH	E	Kitchen/Break Room, Black Cove Base Mastic				14.89	NAD		NAD		NAD
	B	I	F										
	C	198.4/6	G										
	D		H										
04.15.2022-18 22-05-008-18	A	WH	E	Kitchen/Break Room, Black Cove Base Mastic				6.70	NAD		NAD		NAD
	B	I	F										
	C	198.4/6	G										
	D		H										

BULK ASBESTOS TEST REPORT

Client/Address: Core Environmental / 22-48 119th St., College Point, NY 11356					Project: Weedsport Thruway Station								
Laboratory ID: 22-05-008			Date of Report: 05/04/22		Date of Analysis: 05/03/22								
Client ID # Lab ID #	Stereomicroscope Analysis			Sample Description	% Non-Fibrous Material	% Friable Results		% AII	% PLM NOB Results		% TEM NOB Results		% TOTAL Asbestos
04.15.2022-19 22-05-008-19	A	BK	E	Kitchen/Break Room, Black Cove Base				0.39	NAD		NAD		NAD
	B	1	F										
	C	198.4/6	G										
	D		H										
04.15.2022-20 22-05-008-20	A	BK	E	Kitchen/Break Room, Black Cove Base				2.08	NAD		NAD		NAD
	B	1	F										
	C	198.4/6	G										
	D		H										
04.15.2022-21 22-05-008-21	A	WH	E	Kitchen/Break Room, Green Cove Base Mastic				22.12	NAD		NAD		NAD
	B	1	F										
	C	198.4/6	G										
	D		H										
04.15.2022-22 22-05-008-22	A	WH	E	Kitchen/Break Room, Green Cove Base Mastic				14.17	NAD		NAD		NAD
	B	1	F										
	C	198.4/6	G										
	D		H										
04.15.2022-23 22-05-008-23	A	GN	E	Kitchen/Break Room, Green Cove Base				3.22	NAD		NAD		NAD
	B	1	F										
	C	198.4/6	G										
	D		H										
04.15.2022-24 22-05-008-24	A	GN	E	Kitchen/Break Room, Green Cove Base				3.13	NAD		NAD		NAD
	B	1	F										
	C	198.4/6	G										
	D		H										

BULK ASBESTOS TEST REPORT

Client/Address: Core Environmental / 22-48 119th St., College Point, NY 11356					Project: Weedsport Thruway Station								
Laboratory ID: 22-05-008			Date of Report: 05/04/22		Date of Analysis: 05/03/22								
Client ID # Lab ID #	Stereomicroscope Analysis			Sample Description	% Non-Fibrous Material	% Friable Results		% AII	% PLM NOB Results		% TEM NOB Results		% TOTAL Asbestos
04.15.2022-25 22-05-008-25	A	GR	E	Kitchen/Break Room, Window Caulking				3.05	NAD		NAD		NAD
	B	I	F										
	C	198.4/6	G										
	D		H										
04.15.2022-26 22-05-008-26	A	GR	E	Kitchen/Break Room, Window Caulking				7.63	NAD		NAD		NAD
	B	I	F										
	C	198.4/6	G										
	D		H										
04.15.2022-27 22-05-008-27	A	WH	E	Men's Lockroom/Bathroom, Caulking Around Sink				16.25	NAD		NAD		NAD
	B	I	F										
	C	198.4/6	G										
	D		H										
04.15.2022-28 22-05-008-28	A	WH	E	Men's Lockroom/Bathroom, Caulking Around Sink				19.91	NAD		NAD		NAD
	B	I	F										
	C	198.4/6	G										
	D		H										
04.15.2022-29 22-05-008-29	A	WH	E	Men's Lockroom/Bathroom, 4" x 4" White Wall Tile Mastic				1.17	NAD		NAD		NAD
	B	I	F										
	C	198.4/6	G										
	D		H										
04.15.2022-30 22-05-008-30	A	WH	E	Men's Lockroom/Bathroom, 4" x 4" White Wall Tile Mastic				3.52	NAD		NAD		NAD
	B	I	F										
	C	198.4/6	G										
	D		H										

BULK ASBESTOS TEST REPORT

Client/Address: Core Environmental / 22-48 119th St., College Point, NY 11356					Project: Weedsport Thruway Station						
Laboratory ID: 22-05-008			Date of Report: 05/04/22		Date of Analysis: 05/03/22						
Client ID # Lab ID #	Stereomicroscope Analysis			Sample Description	% Non-Fibrous Material	% Friable Results		% AII	% PLM NOB Results	% TEM NOB Results	% TOTAL Asbestos
04.15.2022-31 22-05-008-31	A	BE	E	Men's Lockroom/Bathroom, 4" x 4" White Wall Tile Grout	100.00	NAD					NAD
	B	1	F								
	C	198.1	G								
	D		H								
04.15.2022-32 22-05-008-32	A	BE	E	Men's Lockroom/Bathroom, 4" x 4" White Wall Tile Grout	100.00	NAD					NAD
	B	1	F								
	C	198.1	G								
	D		H								
04.15.2022-33 22-05-008-33	A	BR	E	Men's Lockroom/Bathroom, Ceiling Plaster - Grey	100.00	NAD					NAD
	B	1	F			NVD					
	C	198.1	G								
	D		H								
04.15.2022-34 22-05-008-34	A	BR	E	Men's Lockroom/Bathroom, Ceiling Plaster - Grey	100.00	NAD					NAD
	B	1	F			NVD					
	C	198.1	G								
	D		H								
04.15.2022-35 22-05-008-35	A	BR	E	Men's Lockroom/Bathroom, Ceiling Plaster - Grey	100.00	NAD					NAD
	B	1	F			NVD					
	C	198.1	G								
	D		H								
04.15.2022-36 22-05-008-36	A	WH	E	Men's Lockroom/Bathroom, Ceiling Plaster - White	100.00	NAD					NAD
	B	1	F			NVD					
	C	198.1	G								
	D		H								

BULK ASBESTOS TEST REPORT

Client/Address: Core Environmental / 22-48 119th St., College Point, NY 11356					Project: Weedsport Thruway Station						
Laboratory ID: 22-05-008			Date of Report: 05/04/22		Date of Analysis: 05/03/22						
Client ID # Lab ID #	Stereomicroscope Analysis			Sample Description	% Non-Fibrous Material	% Friable Results		% AII	% PLM NOB Results	% TEM NOB Results	% TOTAL Asbestos
04.15.2022-37 22-05-008-37	A	WH	E	Men's Lockroom/Bathroom, Ceiling Plaster - White	100.00	NAD					NAD
	B	1	F			NVD					
	C	198.1	G								
	D		H								
04.15.2022-38 22-05-008-38	A	WH	E	Men's Lockroom/Bathroom, Ceiling Plaster - White	100.00	NAD					NAD
	B	1	F			NVD					
	C	198.1	G								
	D		H								
04.15.2022-39 22-05-008-39	A	BR/GR	E	Men's Lockroom/Bathroom, Gypsum Board (Sheetrock)	88.00	NAD					NAD
	B	2	F								
	C	198.1	G								
	D	12	H								
04.15.2022-40 22-05-008-40	A	BR/GR	E	Men's Lockroom/Bathroom, Gypsum Board (Sheetrock)	84.00	NAD					NAD
	B	2	F								
	C	198.1	G								
	D	16	H								
04.15.2022-41 22-05-008-41	A	BR	E	Men's Lockroom/Bathroom, Tape Associated With Gypsum Board	0.00	NAD					NAD
	B	1	F								
	C	198.1	G								
	D	100	H								
04.15.2022-42 22-05-008-42	A	BR	E	Men's Lockroom/Bathroom, Tape Associated With Gypsum Board	0.00	NAD					NAD
	B	1	F								
	C	198.1	G								
	D	100	H								

BULK ASBESTOS TEST REPORT

Client/Address: Core Environmental / 22-48 119th St., College Point, NY 11356					Project: Weedsport Thruway Station						
Laboratory ID: 22-05-008			Date of Report: 05/04/22		Date of Analysis: 05/03/22						
Client ID # Lab ID #	Stereomicroscope Analysis			Sample Description	% Non-Fibrous Material	% Friable Results		% AII	% PLM NOB Results	% TEM NOB Results	% TOTAL Asbestos
04.15.2022-43 22-05-008-43	A	WH	E	Men's Lockroom/Bathroom, Joint Compound Associated With Gypsum Board	100.00	NAD					NAD
	B	1	F								
	C	198.1	G								
	D		H								
04.15.2022-44 22-05-008-44	A	WH	E	Men's Lockroom/Bathroom, Joint Compound Associated With Gypsum Board	100.00	NAD					NAD
	B	1	F								
	C	198.1	G								
	D		H								
04.15.2022-45 22-05-008-45	A	WH	E	Mechanical Room, Fiberglass Jacket Around Pipe Insulation	0.00	NAD					NAD
	B	1	F								
	C	198.1	G								
	D	100	H								
04.15.2022-46 22-05-008-46	A	WH	E	Mechanical Room, Fiberglass Jacket Around Pipe Insulation	0.00	NAD					NAD
	B	1	F								
	C	198.1	G								
	D	100	H								
04.15.2022-47 22-05-008-47	A	WH	E	Mechanical Room, Fiberglass Jacket Around Pipe Insulation	0.00	NAD					NAD
	B	1	F								
	C	198.1	G								
	D	100	H								
04.15.2022-48 22-05-008-48	A	WH	E	Women's Lockroom/Bathroom, 2' x 4' Drop Ceiling Tile Above Drop Ceiling Tile					NAD	NAD	NAD
	B	1	F								
	C	198.4/6	G					67.63			
	D		H								

BULK ASBESTOS TEST REPORT

Client/Address: Core Environmental / 22-48 119th St., College Point, NY 11356	Project: Weedsport Thruway Station
Laboratory ID: 22-05-008	Date of Report: 05/04/22
	Date of Analysis: 05/03/22

Client ID # Lab ID #	Stereomicroscope Analysis			Sample Description	% Non-Fibrous Material	% Friable Results		% AII	% PLM NOB Results		% TEM NOB Results		% TOTAL Asbestos
	A	WH	E										
04.15.2022-49 22-05-008-49	A	WH	E	Women's Lockroom/Bathroom, 2' x 4' Drop Ceiling Tile Above Drop Ceiling Tile				65.99	NAD		NAD		NAD
	B	I	F										
	C	198.4/6	G										
	D		H										
04.15.2022-50 22-05-008-50	A	WH	E	Women's Lockroom/Bathroom, Black Cove Base Mastic				1.03	NAD		NAD		NAD
	B	I	F										
	C	198.4/6	G										
	D		H										
04.15.2022-51 22-05-008-51	A	WH	E	Women's Lockroom/Bathroom, Black Cove Base Mastic				10.90	NAD		NAD		NAD
	B	I	F										
	C	198.4/6	G										
	D		H										
04.15.2022-52 22-05-008-52	A	BK	E	Women's Lockroom/Bathroom, Black Cove Base				1.96	NAD		NAD		NAD
	B	I	F										
	C	198.4/6	G										
	D		H										
04.15.2022-53 22-05-008-53	A	BK	E	Women's Lockroom/Bathroom, Black Cove Base				3.63	NAD		NAD		NAD
	B	I	F										
	C	198.4/6	G										
	D		H										
04.15.2022-54 22-05-008-54	A	GR	E	Roof, Caulking Around Edge Of Roof				37.25	9.95	CH	NA		9.95
	B	I	F										
	C	198.6	G										
	D		H										

BULK ASBESTOS TEST REPORT

Client/Address: Core Environmental / 22-48 119th St., College Point, NY 11356					Project: Weedsport Thruway Station											
Laboratory ID: 22-05-008					Date of Report: 05/04/22			Date of Analysis: 05/03/22								
Client ID # Lab ID #	Stereomicroscope Analysis				Sample Description	% Non-Fibrous Material	% Friable Results		% AII	% PLM NOB Results		% TEM NOB Results		% TOTAL Asbestos		
04.15.2022-55 22-05-008-55	A	GR	E		Roof, Caulking Around Edge Of Roof				7.65	NA		NA		SAFP		
	B	1	F													
	C		G													
	D		H													
04.15.2022-56 22-05-008-56	A	BK	E		Roof, Vapor Barrier				14.68	NAD		NAD		NAD		
	B	1	F													
	C	198.4/6	G													
	D		H													
04.15.2022-57 22-05-008-57	A	BK	E		Roof, Vapor Barrier				12.41	NAD		NAD		NAD		
	B	1	F													
	C	198.4/6	G													
	D		H													
04.15.2022-58 22-05-008-58	A	BK	E		Roof, Tar Roof Material				4.05	NAD		NAD		NAD		
	B	1	F													
	C	198.4/6	G													
	D		H													
04.15.2022-59 22-05-008-59	A	BK	E		Roof, Tar Roof Material				2.28	NAD		NAD		NAD		
	B	1	F													
	C	198.4/6	G													
	D		H													
04.15.2022-60 22-05-008-60	A	BR	E	35	Roof, Skeert	20.00				NAD				NAD		
	B	1	F													
	C	198.1	G													
	D	45	H													

BULK ASBESTOS TEST REPORT

Client/Address: Core Environmental / 22-48 119th St., College Point, NY 11356					Project: Weedsport Thruway Station							
Laboratory ID: 22-05-008					Date of Report: 05/04/22			Date of Analysis: 05/03/22				
Client ID # Lab ID #	Stereomicroscope Analysis				Sample Description	% Non-Fibrous Material	% Friable Results		% AII	% PLM NOB Results	% TEM NOB Results	% TOTAL Asbestos
04.15.2022-61 22-05-008-61	A	BR	E	35	Roof, Skeert	20.00	NAD					NAD
	B	1	F									
	C	198.1	G									
	D	45	H									
04.15.2022-62 22-05-008-62	A	BK	E		Roof, Tar Roof Material					NAD	NAD	NAD
	B	1	F									
	C	198.4/6	G					2.97				
	D		H									
04.15.2022-63 22-05-008-63	A	BK	E		Roof, Tar Roof Material					NAD	NAD	NAD
	B	1	F									
	C	198.4/6	G					5.31				
	D		H									
04.15.2022-64 22-05-008-64	A	BK	E		Roof, Caulking On Roof					NAD	NAD	NAD
	B	1	F									
	C	198.4/6	G					29.52				
	D		H									
04.15.2022-65 22-05-008-65	A	BK	E		Roof, Caulking On Roof					NAD	NAD	NAD
	B	1	F									
	C	198.4/6	G					17.34				
	D		H									
04.15.2022-66 22-05-008-66	A	BK	E		Roof, Tar On Metal Flashing					NAD	NAD	NAD
	B	1	F									
	C	198.4/6	G					4.95				
	D		H									

BULK ASBESTOS TEST REPORT

Client/Address: Core Environmental / 22-48 119th St., College Point, NY 11356					Project: Weedsport Thruway Station								
Laboratory ID: 22-05-008			Date of Report: 05/04/22			Date of Analysis: 05/03/22							
Client ID # Lab ID #	Stereomicroscope Analysis			Sample Description	% Non-Fibrous Material	% Friable Results		% AII	% PLM NOB Results		% TEM NOB Results		% TOTAL Asbestos
	A	BK	E										
04.15.2022-67	B	I	F	Roof, Tar On Metal Flashing				8.80					NAD
22-05-008-67	C	198.4/6	G										
	D		H										

BULK ASBESTOS TEST REPORT

Client/Address: Core Environmental / 22-48 119th St., College Point, NY 11356		Project: Weedsport Thruway Station
Laboratory ID: 22-05-008	Date of Report: 05/04/22	Date of Analysis: 05/03/22

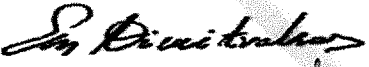
 PLM ANALYST *for DD*
 D. Diallo

 PLM-NOB ANALYST *for DD*
 D. Diallo

 TEM-NOB ANALYST *for EL*
 E. Loukianova

 LABORATORY DIRECTOR
 E. Dimitrakas

LABORATORY ACCREDITATION NUMBERS: NVLAP Lab Code 101958-0, NYSDOH ELAP Lab ID 10955

- Samples will be stored for sixty (60) days. LTS Inc. should be notified within this time frame for a true duplicate analysis.
- Above results relate only to samples submitted and analyzed. This report must not be used to claim product endorsement by NVLAP or any other agency of the U.S. Government. Test reports may not be reproduced except in full and with prior approval of LTS Inc.
- The liability of LTS Inc., with respect to the services charged, shall in no event exceed the amount of the invoice.
- Analytical Methodologies: EPA 600/M4-82-020 (Point Count only) and ELAP Methods 198.1, 198.4, 198.6.
- NAD: No Asbestos Detected, NVD: No Vermiculite Detected, SAFF: Stopped at First Positive, CH: Chrysotile, AMOS: Amosite, TRE: Tremolite, ANTH: Anthophyllite, ACT: Actinolite, and CRO: Crocidolite.
- Stereomicroscopic Analysis: A: Color, B: Layers, C: Methodology, D: Cellulose, E: Fiberglass, F: Hair, G: Vermiculite, H: OTHER
- Color: BK: Black, BR: Brown, Dk BR: Dark Brown, Lt BR: Light Brown, R BR: Reddish Brown, GR: Gray, Dk GR: Dark Gray, Lt GR: Light Gray, BE: Beige, P: Pink, R: Red, T: Tan, WH: White, Off WH: Off White, Y: Yellow, BL: Blue, CR: Cream, GN: Green, O: Orange, Multi.: Multiple Colors



CORE Environmental Consultants, Inc
 22-48 119th Street
 College Point, New York 11356

22-05-008

ACM BULK SAMPLING CHAIN OF CUSTODY / SURVEY FORM

PROJECT NAME : Surveys for Section maintenance facilities - Buffalo Div NYSTA	CORE PROJECT # :	FUNCTIONAL SPACE: Exterior / Kitchen /breakroom
PROJECT LOCATION: Weedsport Thruway Station	SAMPLE COLLECTED BY : Manuel Duran	Reference Drawing : N/A
TURN AROUND TIME: 24 Hours	DATE : 04.15.2022 TIME : 1200	TEL NO : (718) 786-4730
		FAX NO : (718) 786-4764
EMAIL RESULTS TO: mduran@coreenv.com		

Homogeneous Material	SAMPLE ID #	SAMPLE LOCATION	SAMPLE DESCRIPTION	NOTES	PLM	PLM NOB	TEM NOB		
A	04.15.2022- 01	EXTERIOR	BRICK MORTAR		(-)NAD				
	04.15.2022- 02								
B	04.15.2022- 03		CAULKING AROUND WINDOWS				(-)R. CH (+) 2.18% CH		
	04.15.2022- 04								
C	04.15.2022- 05		BRICK MORTAR PATCH			(-)NAD			
	04.15.2022- 06								
D	04.15.2022- 07		GASKET				(-)NAD (-)NAD		
	04.15.2022- 08								
E	04.15.2022- 09		DUCT SEAL				(+).26.17% CH NA	NA NA	
	04.15.2022- 10								
F	04.15.2022- 11		KITCHEN/BREAK ROOM	SOFT CONCRETE UNDERNEATH 12" X 12" BEIGE FLOOR TILE		(-)NAD			
	04.15.2022- 12								
G	04.15.2022- 13			12" X 12" BEIGE FLOOR TILE GROUT AND BACKING			(-)NAD		
	04.15.2022- 14								
H	04.15.2022- 15			2' x 4' DROP CEILING TILE				(-)NAD (-)NAD	
	04.15.2022- 16								

ACM (Y = yes; N = No; NS = Non-Suspect; P = Presumed)

RELINQUISHED BY: Manuel Duran	04.15.2022	23:30	RECEIVED BY: Joe Forchney	5/2/22	12:30
RELINQUISHED BY: (Signature) <i>[Signature]</i>	(Date)	(Time)	RECEIVED BY: (Signature) <i>[Signature]</i>	(Date)	(Time)
Analyzed by: <i>[Signature]</i>	ANALYST (Signature) <i>[Signature]</i>	(Date) 5.3.22	Condition (G = Good/ F = Fair/ P = Poor)	ELAP # 10955	
Analyzed by:	ANALYST (Signature)	(Date)	(Time)	Lab Batch #	

MAY 7 12:13



CORE Environmental Consultants, Inc
 22-48 119th Street
 College Point, New York 11356

Page 2 of 5

22-05-008

ACM BULK SAMPLING CHAIN OF CUSTODY / SURVEY FORM

PROJECT NAME : Surveys for Section maintenance facilities - Buffalo Div NYSTA		CORE PROJECT #:	FUNCTIONAL SPACE: Break Room / Men's Locker Room
PROJECT LOCATION: Weedsport Thruway Station		SAMPLE COLLECTED BY : Manuel Duran	Reference Drawing : N/A
TURN AROUND TIME: ASAP 24 Hours		DATE : 04.15.2022	TIME : 1200
		TEL NO : (718) 786-4730	
		FAX NO : (718) 786-4764	
EMAIL RESULTS TO: mduran@coreenv.com			

Homogeneous Material	SAMPLE ID #	SAMPLE LOCATION	SAMPLE DESCRIPTION	NOTES	PLM	PLM NOB	TEM NOB	
I	04.15.2022- 17	KITCHEN/BREAK ROOM	BLACK COVE BASE MASTIC			(-) NAD	(-) NAD	
	04.15.2022- 18					↓	↓	
J	04.15.2022- 19		BLACK COVE BASE				(-) NAD	(-) NAD
	04.15.2022- 20					↓	↓	
K	04.15.2022- 21		GREEN COVE BASE MASTIC				(-) NAD	(-) NAD
	04.15.2022- 22					↓	↓	
L	04.15.2022- 23		GREEN COVE BASE				(-) NAD	(-) NAD
	04.15.2022- 24					↓	↓	
M	04.15.2022- 25		WINDOW CAULKING				(-) NAD	(-) NAD
	04.15.2022- 26					↓	↓	
N	04.15.2022- 27		CAULKING AROUND SINK				(-) NAD	(-) NAD
	04.15.2022- 28					↓	↓	
O	04.15.2022- 29	MENS LOCKROOM / BATHROOM	4" x 4" WHITE WALL TILE MASTIC			(-) NAD	(-) NAD	
	04.15.2022- 30					↓	↓	
P	04.15.2022- 31	4" x 4" WHITE WALL TILE GROUT				(-) NAD		
	04.15.2022- 32				↓			

ACM (Y = yes; N = No; NS = Non-Suspect; P = Presumed)

RELINQUISHED BY: Manuel Duran	04.15.22 23:30 (Date) (Time)	RECEIVED BY: Joel Forchney	5/12/22 12:30 (Date) (Time)
RELINQUISHED BY: (Signature) <i>[Signature]</i>		RECEIVED BY: (Signature) <i>[Signature]</i>	
Analyzed by: <i>[Signature]</i>	ANALYST (Signature) <i>[Signature]</i>	Condition (G = Good; F = Fair; P = Poor)	ELAP # 10955
Analyzed by: _____	ANALYST (Signature) _____	(Date) _____ (Time) _____	Lab Batch # _____



CORE Environmental Consultants, Inc
 22-48 119th Street
 College Point, New York 11356

Page 3 of 5

22-05-008

ACM BULK SAMPLING CHAIN OF CUSTODY / SURVEY FORM

PROJECT NAME : Surveys for Section maintenance facilities - Buffalo Div NYSTA		CORE PROJECT # :		FUNCTIONAL SPACE: Mens Locker Room/ Mechanical Room	
PROJECT LOCATION: Weedsport Thruway Station		SAMPLE COLLECTED BY : Manuel Duran		Reference Drawing : N/A	
TURN AROUND TIME: ASAP 24 HOURS				DATE : 04.15.2022 TIME : 1200	
				TEL NO : (718) 786-4730	
				FAX NO : (718) 786-4764	
EMAIL RESULTS TO: mduran@coreenv.com					

Homogeneous Material	SAMPLE ID #	SAMPLE LOCATION	SAMPLE DESCRIPTION	NOTES	PLM	PLM NOB	TEM NOB			
Q	04.15.2022- 33	MENS LOCKROOM / BATHROOM	CEILING PLASTER - GREY		(-)RAD,AVD	↓				
	04.15.2022- 34									
	04.15.2022- 35									
R	04.15.2022- 36		MENS LOCKROOM / BATHROOM	CEILING PLASTER - WHITE		(-)RAD,AVD	↓			
	04.15.2022- 37									
	04.15.2022- 38									
S	04.15.2022- 39			MENS LOCKROOM / BATHROOM	GYPSUM BOARD (SHEETROCK)		(-)RAD	↓		
	04.15.2022- 40									
T	04.15.2022- 41				MENS LOCKROOM / BATHROOM	TAPE ASSOCIATED WITH GYPSUM BOARD		(-)RAD	↓	
	04.15.2022- 42									
U	04.15.2022- 43		MENS LOCKROOM / BATHROOM			JOINT COMPOUND ASSOCIATED WITH GYPSUM BOARD		(-)RAD	↓	
	04.15.2022- 44									
V	04.15.2022- 45	MECHANICAL ROOM				FIBERGLASS JACKET AROUND PIPE INSULATION		(-)RAD	↓	
	04.15.2022- 46									
	04.15.2022- 47									

ACM (Y = yes; N = No; NS = Non-Suspect; P = Presumed)

RELINQUISHED BY: Manuel Duran	04.15.22 23:30	RECEIVED BY: Noel Forchona	5/2/22 12:30
RELINQUISHED BY (Signature) <i>[Signature]</i>	(Date) (Time)	RECEIVED BY (Signature) <i>[Signature]</i>	(Date) (Time)
Analyzed by: <i>[Signature]</i>	ANALYST (Signature) <i>[Signature]</i>	ANALYST (Signature) <i>[Signature]</i>	Condition (G = Good; F = Fair; P = Poor) ELAP # 10955
Analyzed by: _____	ANALYST (Signature) _____	ANALYST (Signature) _____	Lab Batch # _____



CORE Environmental Consultants, Inc
 22-48 119th Street
 College Point, New York 11356

Page 4 of 5

22-05-008

ACM BULK SAMPLING CHAIN OF CUSTODY / SURVEY FORM

PROJECT NAME : Surveys for Section maintenance facilities - Buffalo Div NYSTA		CORE PROJECT # :		FUNCTIONAL SPACE: Womens Locker Room / Roof	
PROJECT LOCATION: Weedsport Thruway Station		SAMPLE COLLECTED BY : Manuel Duran		DATE : 04.15.2022 TIME : 1200	
TURN AROUND TIME: 24 24 Hours				TEL NO : (718) 786-4730	
				FAX NO : (718) 786-4764	
EMAIL RESULTS TO: mduran@coreenv.com					

Homogeneous Material	SAMPLE ID #	SAMPLE LOCATION	SAMPLE DESCRIPTION	NOTES	PLM	PLM NOB	TEM NOB
W	04.15.2022- 48	WOMENS LOCKROOM / BATHROOM	2' X 4' DROP CEILING TILE ABOVE DROP CEILING TILE			(-)NAD	(-)NAD
	04.15.2022- 49					↓	↓
X	04.15.2022- 50		BLACK COVE BASE MASTIC			(-)NAD	(-)NAD
	04.15.2022- 51					↓	↓
Y	04.15.2022- 52		BLACK COVE BASE			(-)NAD	(-)NAD
	04.15.2022- 53					↓	↓
Z	04.15.2022- 54		Caulking around Edge of Roof			(+) 9.95/CH NA	NA
	04.15.2022- 55					NA	NA
AA	04.15.2022- 56		Vapor Barrier			(-)NAD	(-)NAD
	04.15.2022- 57					↓	↓
AB	04.15.2022- 58	ROOF	Tar Roof Material			(-)NAD	(-)NAD
	04.15.2022- 59					↓	↓
AC	04.15.2022- 60	Skeert			(-)NAD		
	04.15.2022- 61				↓		
AD	04.15.2022- 62	ROOF	Tar Roof Material			(-)NAD	(-)NAD
	04.15.2022- 63					↓	↓

ACM (Y = yes; N = No; NS = Non-Suspect; P = Presumed)

RELINQUISHED BY: Manuel Duran	04.15.2022 23:30	RECEIVED BY: Joel Forchoney	6/2/22 12:30
RELINQUISHED BY (Signature) <i>[Signature]</i>	(Date) (Time)	RECEIVED BY (Signature) <i>[Signature]</i>	(Date) (Time)
Analyzed by: <i>[Signature]</i>	ANALYST (Signature) <i>[Signature]</i>	(Date) 5-22-22 (Time) 18:00	ELAP # 10955
Analyzed by: _____	ANALYST (Signature)	(Date) (Time)	Lab Batch # _____



CORE Environmental Consultants, Inc
22-48 119th Street
College Point, New York 11356

Page 5 of 5

22-05-008

ACM BULK SAMPLING CHAIN OF CUSTODY / SURVEY FORM

PROJECT NAME : Surveys for Section maintenance facilities - Buffalo Div NYSTA		CORE PROJECT # :	FUNCTIONAL SPACE: Roof
PROJECT LOCATION: Weedsport Thruway Station		SAMPLE COLLECTED BY : Manuel Duran	Reference Drawing : N/A
TURN AROUND TIME: <u>ASAP 24 Hours</u>		DATE : 04.15.2022	TIME : 1200
		TEL NO : (718) 786-4730	
		FAX NO : (718) 786-4764	
EMAIL RESULTS TO: mduran@coreenv.com			

Homogeneous Material	SAMPLE ID #	SAMPLE LOCATION	SAMPLE DESCRIPTION	NOTES	PLM	PLM NOB	TEM NOB
AE	04.15.2022- 64	ROOF	CAULKING ON ROOF			(-)/NAD	(-)/NAD
	04.15.2022- 65						
AF	04.15.2022- 66		TAR ON METAL FLASHING			(-)/NAD	(-)/NAD
	04.15.2022- 67						

ACM (Y = yes; N = No; NS = Non-Suspect; P = Presumed)

RELINQUISHED BY: Manuel Duran <u>(Signature)</u>	<u>04.15.2022</u> (Date)	<u>23:30</u> (Time)	RECEIVED BY: <u>Joel Forchoney</u> (Signature)	<u>5/2/22</u> (Date)	<u>12:30</u> (Time)
Analyzed by: <u>E. Loekialone</u> (Signature)	ANALYST <u>(Signature)</u>	(Date)	<u>Condition (G = Good, F = Fair, P = Poor)</u> <u>after</u>	(Date)	(Time)
Analyzed by: _____	ANALYST <u>(Signature)</u>	(Date)	(Date)	(Time)	Lab Batch # _____

ELAP # 10955

		CORE Environmental Consultants, Inc 22-48 119th Street College Point, New York 11356			Page <u>1</u> of <u>5</u>					
ACM BULK SAMPLING CHAIN OF CUSTODY / SURVEY FORM										
PROJECT NAME : Surveys for Section maintenance facilities - Buffalo Div NYSTA				CORE PROJECT # :		FUNCTIONAL SPACE: Upper Roof				
PROJECT LOCATION: Weedsport Thruway Station				SAMPLE COLLECTED BY : Joseph Zaheer		DATE : 07.13.2022 TIME : 1200				
TURN AROUND TIME: ASAP						TEL NO : (718) 786-4730				
						FAX NO : (718) 786-4764				
EMAIL RESULTS TO: JZaheer@COREenv.com										
Homogeneous Material	SAMPLE ID #	SAMPLE LOCATION	SAMPLE DESCRIPTION	NOTES	PLM	PLM NOB	TEM NOB			
A	A-1	UPPER ROOF	TOP (4TH) LAYER FELT PAPER			(N)NAD	(N)NAD			
	A-2					↓	↓			
	A-3									
	A-4									
	A-5									
B	B-6		UPPER ROOF	3RD LAYER FELT PAPER			(N)NAD	(N)NAD		
	B-7						↓	↓		
	B-8									
	B-9									
	B-10									
C	C-11			UPPER ROOF	TOP (3RD) LAYER SCREED			(N)NAD	(N)NAD	
	C-12							↓	↓	
	C-13									
	C-14									
	C-15									
ACM (Y = yes; N = No; NS = Non-Suspect; P = Presumed)										
RELINQUISHED BY: <u>Joseph Zaheer</u> (Date) <u>7-13-22</u> (Time) <u>17:30</u>		RELINQUISHED BY: _____ (Date/Time) _____ (Signature)			RECEIVED BY: <u>K. Esnard</u> (Date) <u>7/25/22</u> (Time) <u>18:20</u>					
RELINQUISHED BY (Signature) <u>[Signature]</u>		RELINQUISHED BY (Signature) <u>[Signature]</u>			RECEIVED BY (Signature) <u>[Signature]</u>					
Analyzed by: <u>Miller White</u>		ANALYST (Signature) <u>[Signature]</u> (Date) <u>07/26/22</u> (Time) <u>15:50</u>			Condition (G = Good; F = Fair; P = Poor) ELAP # 10955					
Analyzed by: _____		ANALYST (Signature) _____ (Date) _____ (Time) _____			Lab Batch # <u>22-07-170</u>					

JUL 25 8:20

		CORE Environmental Consultants, Inc 22-48 119th Street College Point, New York 11356			Page <u>2</u> of <u>5</u>			
		ACM BULK SAMPLING CHAIN OF CUSTODY / SURVEY FORM						
PROJECT NAME : Surveys for Section maintenance facilities - Buffalo Div NYSTA		CORE PROJECT # :		FUNCTIONAL SPACE: Upper Roof				
PROJECT LOCATION: Weedsport Thruway Station		SAMPLE COLLECTED BY : Joseph Zaheer		DATE : 07.13.2022 TIME : 1200				
TURN AROUND TIME: ASAP				TEL NO : (718) 786-4730				
				FAX NO : (718) 786-4764				
EMAIL RESULTS TO: JZaheer@COREenv.com								
Homogeneous Material	SAMPLE ID #	SAMPLE LOCATION	SAMPLE DESCRIPTION	NOTES	PLM	PLM NOB	TEM NOB	
D	D-16	UPPER ROOF	2ND LAYER FELT PAPER			(-)NAD	(-)NAD	
	D-17					↓	↓	
	D-18							
	D-19							
	D-20							
E	E-21			2ND LAYER SCREED		(-)NAD		
	E-22					↓		
	E-23							
	E-24							
	E-25							
F	F-26			BOTTOM (1ST) LAYER FELT PAPER			(-)NAD	(-)NAD
	F-27						↓	↓
	F-28							
	F-29							
	F-30							
ACM (Y = yes; N = No; NS = Non-Suspect; P = Presumed)								
RELINQUISHED BY: <u>Joseph Zaheer</u>		RELINQUISHED BY: _____		RECEIVED BY: <u>K. Esnard</u>				
(Date) <u>7-13-22</u> (Time) <u>17:30</u>		(Date/Time) _____		(Date) <u>7/25/22</u> (Time) <u>08:20</u>				
RELINQUISHED BY (Signature) <u>[Signature]</u>		RELINQUISHED BY (Signature) _____		RECEIVED BY (Signature) <u>[Signature]</u>				
Analyzed by: <u>M. Miller White</u>		ANALYST (Signature) <u>[Signature]</u>		Condition (G = Good; F = Fair; P = Poor) _____				
Analyzed by: _____		ANALYST (Signature) _____		ELAP # 10955				
		(Date) _____ (Time) _____		Lab Batch # <u>22-07-170</u>				

		CORE Environmental Consultants, Inc 22-48 119th Street College Point, New York 11356			Page <u>3</u> of <u>5</u>		
ACM BULK SAMPLING CHAIN OF CUSTODY / SURVEY FORM							
PROJECT NAME : Surveys for Section maintenance facilities - Buffalo Div NYSTA				CORE PROJECT # :		FUNCTIONAL SPACE: Upper Roof	
PROJECT LOCATION: Weedsport Thruway Station				SAMPLE COLLECTED BY: Joseph Zaheer		DATE: 07.13.2022 TIME: 1200	
TURN AROUND TIME: ASAP						TEL NO: (718) 786-4730	
						FAX NO: (718) 786-4764	
EMAIL RESULTS TO: JZaheer@COREenv.com							
Homogeneous Material	SAMPLE ID #	SAMPLE LOCATION	SAMPLE DESCRIPTION	NOTES	PLM	PLM NOB	TEM NOB
G	G-31	UPPER ROOF	BOTTOM (1ST) LAYER SCREED		(-)NAD		
	G-32						
	G-33						
	G-34						
	G-35						
H	H-36		TAR ROOF MATERIAL			(-)NAD	(-)NAD
	H-37						
	H-38						
	H-39						
I	I-41		ROOF CAULKING			(-)NAD	(-)NAD
	I-42						
J	J-43	EDGE CAULKING			(-)NAD	(-)NAD	
	J-44						
K	K-45	PITCH POCKET TAR			(-)NAD	(-)NAD	
	K-46						
ACM (Y = yes; N = No; NS = Non-Suspect; P = Presumed)							
RELINQUISHED BY: <u>Joseph Zaheer</u>		RELINQUISHED BY: _____		RECEIVED BY: <u>K. E. Smard</u>			
(Signature) <u>[Signature]</u>		(Signature) _____		(Signature) <u>[Signature]</u>			
(Date) <u>7-13-22</u>		(Date/Time) _____		(Date) <u>7/25/22</u> (Time) <u>08:20</u>			
(Time) <u>17:30</u>		(Date/Time) _____		(Date) <u>07/26/22</u> (Time) <u>15:50</u>			
ANALYZED BY: <u>Miller White</u>		ANALYZED BY: <u>[Signature]</u>		ELAP # 10955			
(Signature) _____		(Signature) _____		Lab Batch # <u>22-07-170</u>			
(Date) _____		(Date) _____		(Date) _____ (Time) _____			

		CORE Environmental Consultants, Inc 22-48 119th Street College Point, New York 11356		Page <u>4</u> of <u>5</u>				
ACM BULK SAMPLING CHAIN OF CUSTODY / SURVEY FORM								
PROJECT NAME : Surveys for Section maintenance facilities - Buffalo Div NYSTA			CORE PROJECT # :		FUNCTIONAL SPACE: Lower Roof			
PROJECT LOCATION: Weedsport Thruway Station			SAMPLE COLLECTED BY : Joseph Zaheer		DATE : 07.13.2022 TIME : 1200			
TURN AROUND TIME: ASAP					TEL NO : (718) 786-4730			
					FAX NO : (718) 786-4764			
EMAIL RESULTS TO: JZaheer@COREenv.com								
Homogeneous Material	SAMPLE ID #	SAMPLE LOCATION	SAMPLE DESCRIPTION	NOTES	PLM	PLM NOB	TEM NOB	
L	L-47	LOWER ROOF	TOP LAYER FELT PAPER			(-)NAD	(-)NAD	
	L-48					↓	↓	
M	M-49		BOTTOM LAYER FELT PAPER				(-)NAD	(-)NAD
	M-50					↓	↓	
N	N-51		SCREED			(-)NAD		
	N-52					↓		
O	O-53		TAR ROOF MATERIAL				(-)NAD	(-)NAD
	O-54					↓	↓	
P	P-55		METAL TRIM GLUE				(-)NAD	(-)NAD
	P-56					↓	↓	
Q	Q-57		BOLT CAULK				(-)NAD	(-)NAD
	Q-58					↓	↓	
R	R-59	CONDUIT GLUE				(-)NAD	(-)NAD	
	R-60				↓	↓		
S	S-61	ROOF CAULKING				(-)NAD	(-)NAD	
	S-62				↓	↓		
ACM (Y = yes; N = No; NS = Non-Suspect; P = Presumed)								
RELINQUISHED BY: <u>Joseph Zaheer</u>		(Date) <u>7-13-22</u>	(Time) <u>17:30</u>	RELINQUISHED BY: <u>K. Esnard</u>		(Date) <u>7/27/22</u>	(Time) <u>08:20</u>	
RELINQUISHED BY: <u>[Signature]</u>				RECEIVED BY: <u>[Signature]</u>				
Analyzed by: <u>Miller White</u>		ANALYST (Signature) <u>[Signature]</u>		ANALYST (Signature) <u>[Signature]</u>		Condition (G = Good; F = Fair; P = Poor)		
Analyzed by: _____		ANALYST (Signature) _____		ANALYST (Signature) _____		ELAP # 10955		
		(Date) <u>07/27/22</u> (Time) <u>15:50</u>				Lab Batch # <u>22-07-170</u>		

		CORE Environmental Consultants, Inc 22-48 119th Street College Point, New York 11356		Page <u>5</u> of <u>5</u>			
ACM BULK SAMPLING CHAIN OF CUSTODY / SURVEY FORM							
PROJECT NAME : Surveys for Section maintenance facilities - Buffalo Div NYSTA			CORE PROJECT # :		FUNCTIONAL SPACE: Lower Roof		
PROJECT LOCATION: Weedsport Thruway Station			SAMPLE COLLECTED BY : Joseph Zaheer		DATE : 07.13.2022 TIME : 1200		
TURN AROUND TIME: ASAP					TEL NO : (718) 786-4730		
					FAX NO : (718) 786-4764		
EMAIL RESULTS TO: JZaheer@COREenv.com							
Homogeneous Material	SAMPLE ID #	SAMPLE LOCATION	SAMPLE DESCRIPTION	NOTES	PLM	PLM NOB	TEM NOB
T	T-63	LOWER ROOF	PITCH POCKET TAR			L-NAD	L-NAD
	T-64					↓	↓
RELINQUISHED BY: <u>Joseph Zaheer</u>		<u>7-13-22</u>	<u>17:30</u>	RELINQUISHED BY:	RECEIVED BY: <u>K. Esmeral</u>		
RELINQUISHED BY (Signature)		(Date)	(Time)	RELINQUISHED BY (Signature)	(Date/Time)	RECEIVED BY (Signature)	(Date) <u>7/25/22</u> (Time) <u>08:20</u>
Analyzed by: <u>Miller White</u>		ANALYST (Signature) <u>[Signature]</u>		ANALYST (Signature) <u>[Signature]</u>		Condition (G = Good; F = Fair; P = Poor)	
Analyzed by:		ANALYST (Signature)		ANALYST (Signature)		ELAP # 10955	
		ANALYST (Signature)		ANALYST (Signature)		Lab Batch # <u>22-07-170</u>	



APPENDIX B

Company and Personnel Licenses

New York State – Department of Labor

Division of Safety and Health
 License and Certificate Unit
 State Campus, Building 12
 Albany, NY 12240

ASBESTOS HANDLING LICENSE

Core Environmental Consultants, Inc.

2312 Wehrle Drive

Williamsville, NY 14221

FILE NUMBER: 12-63272

LICENSE NUMBER: 63272

LICENSE CLASS: RESTRICTED

DATE OF ISSUE: 01/04/2022

EXPIRATION DATE: 01/31/2023

Duly Authorized Representative – Teresa S Tramposch:

This license has been issued in accordance with applicable provisions of Article 30 of the Labor Law of New York State and of the New York State Codes, Rules and Regulations (12 NYCRR Part 56). It is subject to suspension or revocation for a (1) serious violation of state, federal or local laws with regard to the conduct of an asbestos project, or (2) demonstrated lack of responsibility in the conduct of any job involving asbestos or asbestos material.

This license is valid only for the contractor named above and this license or a photocopy must be prominently displayed at the asbestos project worksite. This license verifies that all persons employed by the licensee on an asbestos project in New York State have been issued an Asbestos Certificate, appropriate for the type of work they perform, by the New York State Department of Labor.

Amy Phillips, Director
 For the Commissioner of Labor

STATE OF NEW YORK - DEPARTMENT OF LABOR
ASBESTOS CERTIFICATE



MANUEL E DURAN
CLASS(EXPIRES)
C ATEC(07/22) D INSP(07/22)
H PM (07/22)

CERT# 09-10896
DMV# 758007801

MUST BE CARRIED ON ASBESTOS PROJECTS



NYC DEP ASBESTOS CONTROL PROGRAM
ASBESTOS CERTIFICATE





TRAMPOSCH,
RONALD
INVESTIGATOR
132112

EXPIRES: 07/31/2023
DOB: 07/07/1960 M 6' 01"

MUST BE CARRIED ON ALL ASBESTOS PROJECTS



STATE OF NEW YORK - DEPARTMENT OF LABOR
ASBESTOS CERTIFICATE



JOSEPH J ZAHEER
CLASS(EXPIRES)
C ATEC(05/23) D INSP(05/23)
H PM (05/23)

CERT# 21-16549
DMV# 729828959

MUST BE CARRIED ON ASBESTOS PROJECTS





APPENDIX C

Laboratory Accreditations

NEW YORK STATE DEPARTMENT OF HEALTH
WADSWORTH CENTER



Expires 12:01 AM April 01, 2022
Issued April 01, 2021

CERTIFICATE OF APPROVAL FOR LABORATORY SERVICE

Issued in accordance with and pursuant to section 502 Public Health Law of New York State

MR. EMANUEL DIMITRAKAS
LABORATORY TESTING SERVICES INC
45-09 GREENPOINT AVENUE
LONG ISLAND CITY, NY 11104

NY Lab Id No: 10955

is hereby APPROVED as an Environmental Laboratory for the category
ENVIRONMENTAL ANALYSES SOLID AND HAZARDOUS WASTE
All approved subcategories and/or analytes are listed below:

Miscellaneous

Asbestos in Friable Material	Item 198.1 of Manual EPA 600/M4/82/020
Asbestos in Non-Friable Material-PLM	Item 198.6 of Manual (NOB by PLM)
Asbestos in Non-Friable Material-TEM	Item 198.4 of Manual
Asbestos-Vermiculite-Containing Material	Item 198.8 of Manual
Lead in Dust Wipes	EPA 7000B
Lead in Paint	ASTM D3335-85A

Sample Preparation Methods

ASTM E-1644-17

Serial No.: 62852

Property of the New York State Department of Health. Certificates are valid only at the address shown, must be conspicuously posted, and are printed on secure paper. Continued accreditation depends on successful ongoing participation in the Program. Consumers are urged to call (518) 485-6570 to verify the laboratory's accreditation status.

NEW YORK STATE DEPARTMENT OF HEALTH
WADSWORTH CENTER



Expires 12:01 AM April 01, 2022
Issued April 01, 2021

CERTIFICATE OF APPROVAL FOR LABORATORY SERVICE

Issued in accordance with and pursuant to section 502 Public Health Law of New York State

**MR. EMANUEL DIMITRAKAS
LABORATORY TESTING SERVICES INC
45-09 GREENPOINT AVENUE
LONG ISLAND CITY, NY 11104**

NY Lab Id No: 10955

*is hereby APPROVED as an Environmental Laboratory for the category
ENVIRONMENTAL ANALYSES AIR AND EMISSIONS
All approved subcategories and/or analytes are listed below:*

Metals I

Lead, Total NIOSH 7082

Miscellaneous

Asbestos 40 CFR 763 APX A No. III

Fibers NIOSH 7400 A RULES

Serial No.: 62853

Property of the New York State Department of Health. Certificates are valid only at the address shown, must be conspicuously posted, and are printed on secure paper. Continued accreditation depends on successful ongoing participation in the Program. Consumers are urged to call (518) 485-5570 to verify the laboratory's accreditation status.

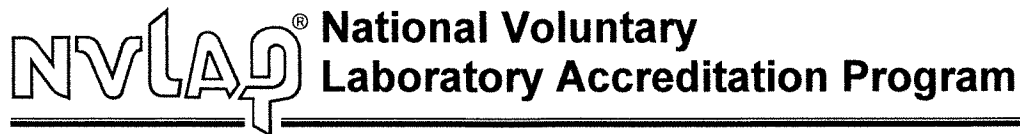

SCOPE OF ACCREDITATION TO ISO/IEC 17025:2017

Laboratory Testing Services Inc.
 45-09 Greenpoint Avenue
 Long Island City, NY 11104
 Mr. Emanuel Dimitrakas
 Phone: 718-389-3470 Fax: 718-389-3471
 Email: edimitrakas@labtestingservices.com

ASBESTOS FIBER ANALYSIS

NVLAP LAB CODE 101958-0

Bulk Asbestos Analysis

<u>Code</u>	<u>Description</u>
18/A01	EPA -- 40 CFR Appendix E to Subpart E of Part 763, Interim Method of the Determination of Asbestos in Bulk Insulation Samples
18/A03	EPA 600/R-93/116: Method for the Determination of Asbestos in Bulk Building Materials

Airborne Asbestos Analysis

<u>Code</u>	<u>Description</u>
18/A02	U.S. EPA's "Interim Transmission Electron Microscopy Analytical Methods-Mandatory and Nonmandatory-and Mandatory Section to Determine Completion of Response Actions" as found in 40 CFR, Part 763, Subpart E, Appendix A.

A handwritten signature in black ink, appearing to read "Dana S. Gorman".

For the National Voluntary Laboratory Accreditation Program

United States Department of Commerce
National Institute of Standards and Technology

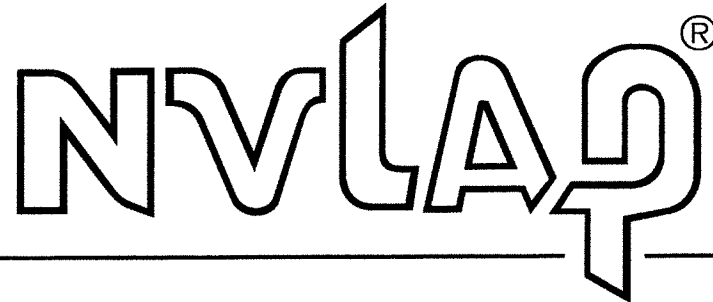

Certificate of Accreditation to ISO/IEC 17025:2017

NVLAP LAB CODE: 101958-0

Laboratory Testing Services Inc.
Long Island City, NY

*is accredited by the National Voluntary Laboratory Accreditation Program for specific services,
listed on the Scope of Accreditation, for:*

Asbestos Fiber Analysis

*This laboratory is accredited in accordance with the recognized International Standard ISO/IEC 17025:2017.
This accreditation demonstrates technical competence for a defined scope and the operation of a laboratory quality
management system (refer to joint ISO-ILAC-IAF Communique dated January 2009).*

2021-07-01 through 2022-06-30

Effective Dates



[Signature]
For the National Voluntary Laboratory Accreditation Program



NEW YORK STATE THRUWAY AUTHORITY – SYRACUSE DIVISION
MAINTENANCE SECTION BUILDING ADDITION AND ROOF REPLACEMENT

APPENDIX D

Bulk Sample Location Drawings

August 01, 2022



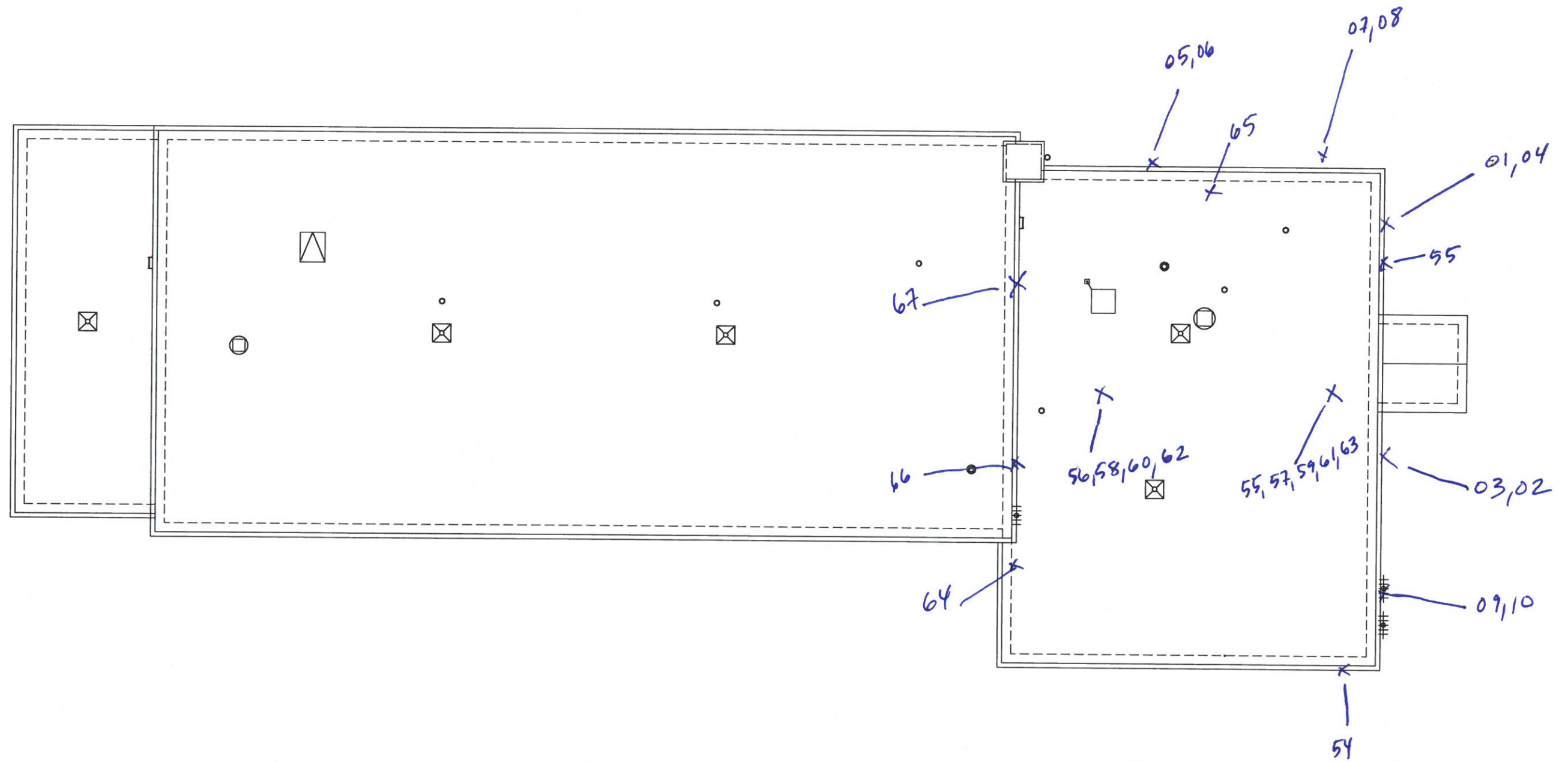

[Handwritten signature]

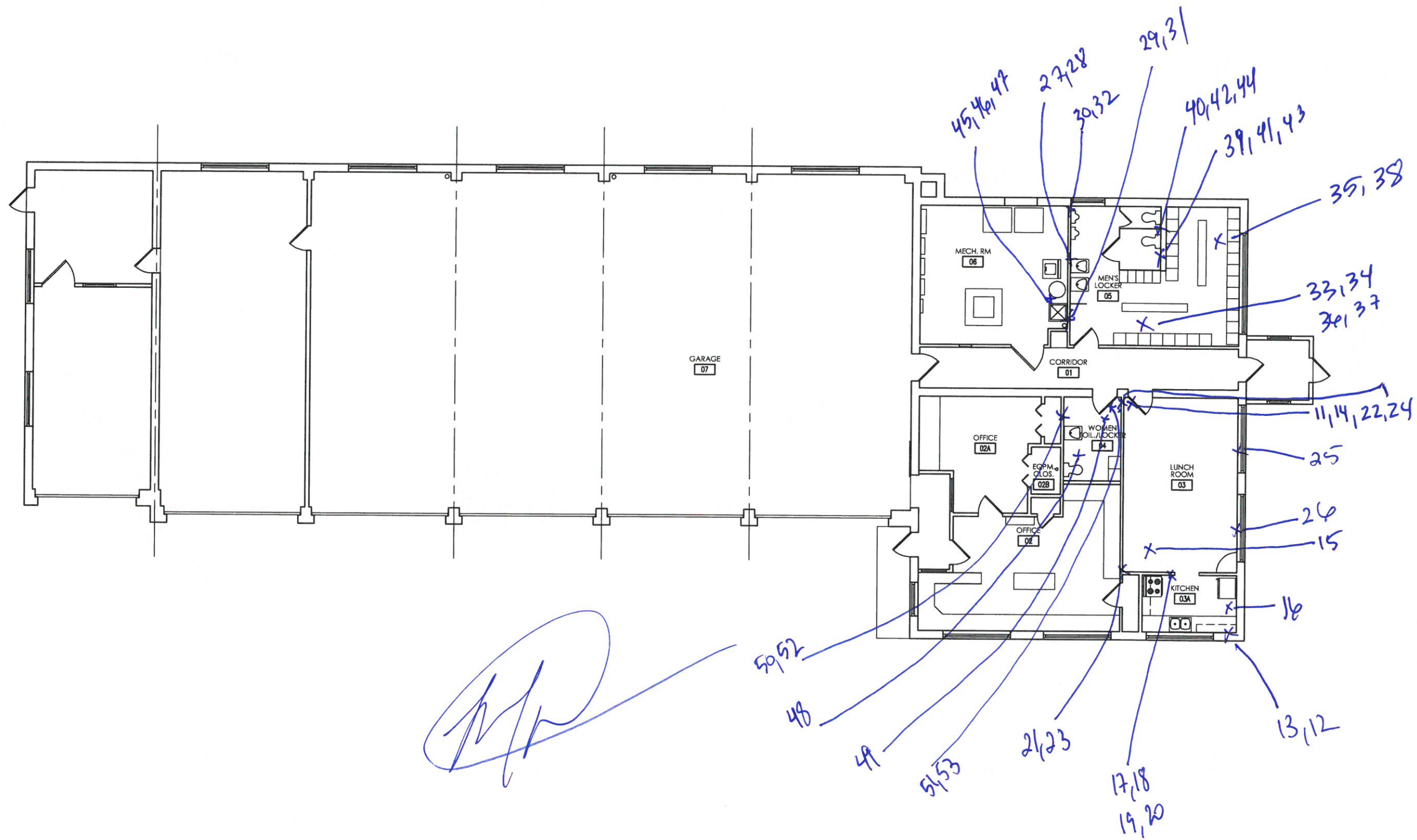

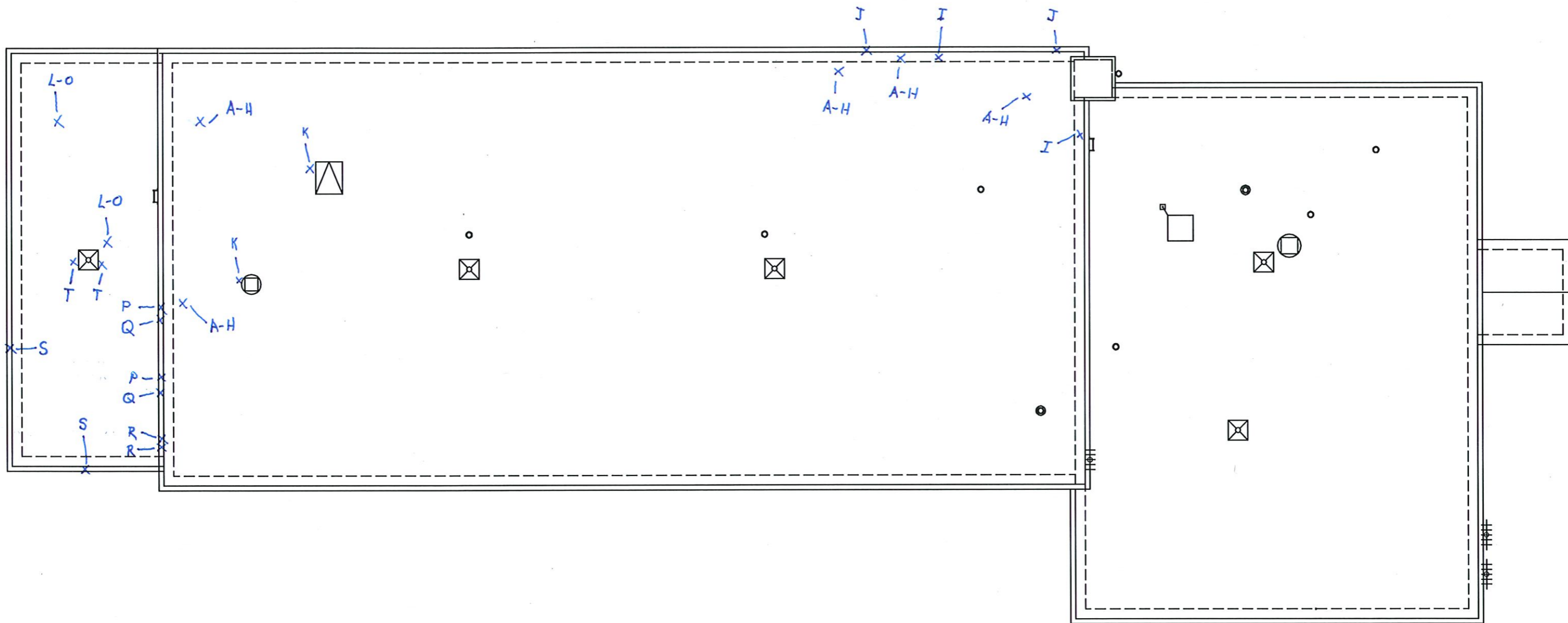

Handwritten signature



APPENDIX E

Previous Reports

NA / Not Applicable

SECTION 003132 – GEOTECHNICAL DATA

1.1 GEOTECHNICAL DATA

- A. This Section with its referenced attachments is part of the Procurement and Contracting Requirements for Project. They provide Owner's information for Bidders' convenience and are intended to supplement rather than serve in lieu of Bidders' own investigations. They are made available for Bidders' convenience and information but are not a warranty of existing conditions.
- B. The available geotechnical investigation information for the site of this Project is attached to this Section. It consists of borings logs on the site of the proposed addition.

END OF SECTION 003132

THIS PAGE INTENTIONALLY LEFT BLANK

WEEDSPORT MAINTENANCE MILE POST 304.19

GRID
NORTH



PARKING LOT
EDGE OF PAVEMENT

BORING HOLE
NORTHING: 1115218.28
EASTING: 826243.44
ELEVATION: 397.28

FLAGGED
GAS LINE

FLAGGED
WATER LINE

BORING HOLE
NORTHING: 1115187.69
EASTING: 826242.60
ELEVATION: 397.06

FLAGGED VERIZON
LINE 3

FLAGGED VERIZON
LINE 1

FLAGGED VERIZON
LINE 2

DM-X-02

DM-X-01

THE AS-DRILLED LOCATIONS AND GROUND ELEVATIONS OF THE BORINGS WERE SURVEYED BY NEW YORK STATE THRUWAY AUTHORITY. ELEVATIONS ARE REPORTED ON THE NORTH AMERICAN VERTICAL DATUM OF 1988 (NAVD 88) IN U.S. SURVEY FEET. HORIZONTAL COORDINATES ARE REPORTED ON THE NEW YORK STATE PLANE COORDINATE SYSTEM (NYSPCS) OF 1983, CENTRAL ZONE (NAD 83) IN U.S. SURVEY FEET.

SM 282 E 12/02	STATE OF NEW YORK DEPARTMENT OF TRANSPORTATION GEOTECHNICAL ENGINEERING BUREAU SUBSURFACE EXPLORATION LOG				HOLE <u>FH-X-1</u>
PSN <u>13179</u>	BORNUM <u>1</u>				LINE _____
REGION <u>3</u>				STA _____	
COUNTY <u>CAYUGA</u>				OFFSET <u>ft</u>	
PIN <u>THWY.ES.301</u>				SURF. ELEV. <u>397.28</u>	
PROJECT <u>WEEDSPORT THRUWAY SHOP</u>				DEPTH TO WATER <u>SEE NOTE</u>	
ACTUAL COORDINATES <u>(N) 1,115,218.280 (E) 826,243.440</u>	DATUM <u>NAD83</u>				
DATE START <u>18-NOV-2022</u>	DATE FINISH <u>18-NOV-2022</u>				
CASING O. D. <u>7 5/8 in</u>	I. D. <u>3 1/4 in</u>	WT OF HAMMER-CASING <u>140 lb</u>	HAMMER FALL-CASING <u>30 in</u>		
SAMPLER O. D. <u>2 in</u>	I. D. <u>1 3/8 in</u>	WT OF HAMMER-SAMPLER <u>140 lb</u>	HAMMER FALL-SAMPLER <u>30 in</u>		

CASING BLOWS/ft	DEPTH ft BELOW SURFACE	SAMPLE NO.	BLOWS ON SAMPLER in				MOIST. CONT. (%)	DESCRIPTION OF SOIL AND ROCK
			0-6	6-12	12-18	18-24		
0.0	J1	1	2	13	15	10%	(0.00) Brown Gravelly SILT With Root Fibers (M-NPL)	
	J2	17	11	6	7	12%	(2.00) Brown/Red Gravelly SILT (M-NPL)	
5.0	J3	4	4	4	6	19%	(4.00) Brown Clayey SILT With Fine Gravel Pieces (M-LPL)	
	J4	3	3	3	4	25%	(6.00) Brown Varved Fine Sandy SILT/ Clayey SILT (M-LPL)	
	J5A	4	5	5		15%	(8.00) Brown Fine Sandy SILT With Fine Gravel Pieces (M-NPL)	
10.0	J5B				7	12%	(9.50) Brown Silty Fine SAND Gravelly (M-NPL)	
15.0	J6	3	17	29		11%	(15.00) Brown Silty Decomposed ROCK Fine Sandy (M-NPL)	
20.0	J7	20	50			12%	(20.00) Brown Fine Sandy SILT With Decomposed Rock (M-NPL)	
25.0	R1						(21.00) Run #1 Drilled from 21'0" To 26'0" ROCK REC. 36" 60% 4 Pieces and Fragments NWD4 DOUBLE TUBE SWIVEL	

The subsurface information shown here was obtained for design and estimate purposes. It is made available so that users may have access to the same information available to the State. It is presented in good faith. By the nature of the exploration process, the information represents only a small fraction of the total volume of the material at the site. Interpolation between data samples may not be indicative of the actual material encountered.

DRILL RIG OPERATOR Andrew Johnston
 SOIL & ROCK DESCRIPTION A. Zerebovich/D. Landau
 REG GEOTECHNICAL ENGINEER Ernest Holmberg, GEB Subsurface Section
 DATE APPROVED 01-DEC-2022
 RESIDENT ENGINEER _____
 STRUCTURE NAME Weedspport Thruway Shop B.I.N. _____
 SHEET 1 OF 2 HOLE FH-X-1

CONTRACT _____ CONTRACTOR MOGEB

SM 282 E 12/02

PSN 13179 BORNUM 1
 REGION 3
 COUNTY CAYUGA
 PIN THWY.ES.301

STATE OF NEW YORK
 DEPARTMENT OF TRANSPORTATION
 GEOTECHNICAL ENGINEERING BUREAU
 SUBSURFACE EXPLORATION LOG



HOLE FH-X-1
 LINE _____
 STA _____
 OFFSET ft

PROJECT WEEDSPORT THRUWAY SHOP SURF. ELEV. 397.28
 ACTUAL COORDINATES (N) 1,115,218.280 (E) 826,243.440 DATUM NAD83 DEPTH TO WATER SEE NOTE
 DATE START 18-NOV-2022 DATE FINISH 18-NOV-2022

CASING O. D. 7 5/8 in I. D. 3 1/4 in WT OF HAMMER-CASING 140 lb HAMMER FALL-CASING 30 in
 SAMPLER O. D. 2 in I. D. 1 3/8 in WT OF HAMMER-SAMPLER 140 lb HAMMER FALL-SAMPLER 30 in

CASING BLOWS/ft	DEPTH ft BELOW SURFACE	SAMPLE NO.	BLOWS ON SAMPLER in					MOIST. CONT. (%)	DESCRIPTION OF SOIL AND ROCK
			0	6	12	18	24		
			6	12	18	24			
25.0									
		R2						(26.00) Run #2 Drilled from 26'0" To 31'0" ROCK REC. 55.2" 92% 14 Pieces and Fragments NWD4 DOUBLE TUBE SWIVEL	
30.0									

BOTTOM OF HOLE AT 31.00 ft

Automatic hammer used for all sampling depths.
 24 inch long sampler used for sampling top 10 feet, 18 inch long sampler used for rest of sampling.

DATE	TIME	DEPTH ft			ARTESIAN HEAD HEIGHT ABOVE GROUND	FILLED WITH WATER AT END OF DAY
		HOLE	CASING	WATER		
18-Nov-22	12:00	31.00	20.00	9.00		

The subsurface information shown here was obtained for design and estimate purposes. It is made available so that users may have access to the same information available to the State. It is presented in good faith. By the nature of the exploration process, the information represents only a small fraction of the total volume of the material at the site. Interpolation between data samples may not be indicative of the actual material encountered.

DRILL RIG OPERATOR Andrew Johnston
 SOIL & ROCK DESCRIPTION A. Zerebovich/D. Landau
 REG GEOTECHNICAL ENGINEER Ernest Holmberg, GEB Subsurface Section
 DATE APPROVED 01-DEC-2022
 RESIDENT ENGINEER _____
 STRUCTURE NAME Weedspport Thruway Shop B.I.N. _____

CONTRACT _____ CONTRACTOR MOGEB

SHEET 2 OF 2 HOLE FH-X-1

SM 282 E 12/02	STATE OF NEW YORK DEPARTMENT OF TRANSPORTATION GEOTECHNICAL ENGINEERING BUREAU SUBSURFACE EXPLORATION LOG					HOLE <u>FH-X-2</u>
PSN <u>13179</u>	BORNUM <u>2</u>					LINE _____
REGION <u>3</u>					STA _____	
COUNTY <u>CAYUGA</u>					OFFSET <u>ft</u>	
PIN <u>THWY.ES.301</u>					SURF. ELEV. <u>397.06</u>	
PROJECT <u>WEEDSPORT THRUWAY SHOP</u>					DEPTH TO WATER <u>4</u>	
ACTUAL COORDINATES <u>(N) 1,115,187.690 (E) 826,242.600</u>	DATUM <u>NAD83</u>					
DATE START <u>18-NOV-2022</u>	DATE FINISH <u>18-NOV-2022</u>					
CASING O. D. <u>7 5/8 in</u>	I. D. <u>3 1/4 in</u>	WT OF HAMMER-CASING <u>140 lb</u>	HAMMER FALL-CASING <u>30 in</u>			
SAMPLER O. D. <u>2 in</u>	I. D. <u>1 3/8 in</u>	WT OF HAMMER-SAMPLER <u>140 lb</u>	HAMMER FALL-SAMPLER <u>30 in</u>			

CASING BLOWS/ft	DEPTH ft BELOW SURFACE	SAMPLE NO.	BLOWS ON SAMPLER in				MOIST. CONT. (%)	DESCRIPTION OF SOIL AND ROCK
			0	6	12	18		
	0.0	J1	1	2	3	1	24%	(0.00) Brown Fine Sandy SILT With Root Fibers (M-NPL)
		J2	WOH	WOH	4	6	26%	(2.00) Black Organic Silty Fine GRAVEL (M-NPL)
	5.0	J3	3	3	3	3		(4.00) No Recovery
		J4	2	5	5	4	20%	(6.00) Brown Silty Fine SAND Gravelly (W-NPL)
	10.0	J5	2	3	4	4	16%	(8.00) Brown Silty Fine SAND Gravelly (W-NPL)
	15.0	J6	3	5	6		10%	(15.00) Brown Gravelly SILT Clayey With Fine Sand (M-LPL)
	20.0	J7	9	15	35		12%	(20.00) Brown/Red Fine Sandy SILT With Decomposed Rock (M-NPL)
	25.0	R1						(21.50) Run #1 Drilled from 21'6" To 26'6" ROCK REC. 44.4" 74% Fragments NWD4 DOUBLE TUBE SWIVEL

The subsurface information shown here was obtained for design and estimate purposes. It is made available so that users may have access to the same information available to the State. It is presented in good faith. By the nature of the exploration process, the information represents only a small fraction of the total volume of the material at the site. Interpolation between data samples may not be indicative of the actual material encountered.

DRILL RIG OPERATOR Andrew Johnston
 SOIL & ROCK DESCRIPTION A. Zerebovich/D. Landau
 REG GEOTECHNICAL ENGINEER Ernest Holmberg, GEB Subsurface Section
 DATE APPROVED 01-DEC-2022
 RESIDENT ENGINEER _____
 STRUCTURE NAME Weedspport Thruway Shop B.I.N. _____
 SHEET 1 OF 2 HOLE FH-X-2

CONTRACT _____ CONTRACTOR MOGEB

SM 282 E 12/02

PSN 13179 BORNUM 2REGION 3COUNTY CAYUGAPIN THWY.ES.301PROJECT WEEDSPORT THRUWAY SHOPACTUAL COORDINATES (N) 1,115,187.690 (E) 826,242.600 DATUM NAD83DATE START 18-NOV-2022DATE FINISH 18-NOV-2022CASING O. D. 7 5/8 in I. D. 3 1/4 in WT OF HAMMER-CASING 140 lb HAMMER FALL-CASING 30 inSAMPLER O. D. 2 in I. D. 1 3/8 in WT OF HAMMER-SAMPLER 140 lb HAMMER FALL-SAMPLER 30 inSTATE OF NEW YORK
DEPARTMENT OF TRANSPORTATION
GEOTECHNICAL ENGINEERING BUREAU
SUBSURFACE EXPLORATION LOGHOLE FH-X-2

LINE _____

STA _____

OFFSET ftSURF. ELEV. 397.06DEPTH TO WATER 4

CASING BLOWS/ft	DEPTH ft BELOW SURFACE	SAMPLE NO.	BLOWS ON SAMPLER in				MOIST. CONT. (%)	DESCRIPTION OF SOIL AND ROCK
			0	6	12	18		
			6	12	18	24		
	25.0							

BOTTOM OF HOLE AT 26.50 ft

Automatic hammer used for all sampling depths.
24 inch long sampler used for sampling top 10 feet, 18 inch long
sampler used for rest of sampling.

The subsurface information shown here was obtained for design and estimate purposes. It is made available so that users may have access to the same information available to the State. It is presented in good faith. By the nature of the exploration process, the information represents only a small fraction of the total volume of the material at the site. Interpolation between data samples may not be indicative of the actual material encountered.

DRILL RIG OPERATOR Andrew JohnstonSOIL & ROCK DESCRIPTION A. Zerebovich/D. Landau

REG GEOTECHNICAL

ENGINEER Ernest Holmberg, GEB Subsurface SectionDATE APPROVED 01-DEC-2022

RESIDENT ENGINEER _____

STRUCTURE NAME _____ B.I.N. _____

Weedspport Thruway ShopCONTRACT _____ CONTRACTOR MOGEB

SHEET 2 OF 2

HOLE FH-X-2

ITEM 627.0001 25**GENERAL REQUIREMENTS****SECTION 010000 – GENERAL NOTES****PART 1 - COMMON COMPONENTS AND CONCERNS****1.1 GENERAL**

- A. All work included under this contract is to be governed by and in conformance with the current version of the New York State Department of Transportation's (NYSDOT) "Standard Specifications" except as modified in these Plans and by the Proposal.
- B. The Contract Documents (Plans and Specifications) utilize specification item numbers from or in the NYSDOT's "Standard Specifications" format. Special Specifications for the Architectural work have been written utilizing Item Number Series "627.xxxx--25". The Item Number Series "627.xxxx--25" incorporate the Construction Specification Institute's (CSI) format for Divisions 2 through 49.
- C. The Contractor may include the cost for providing required insurances and bonds under item number "627.0001--25".
- D. The project descriptions are general outlines of the work and shall not be construed as complete descriptions of the work to be performed under this Contract. In addition, the project descriptions do not necessarily indicate the construction sequence.
- E. The Contractor is advised that additional "Notes" will be found on the drawings. Such "Notes", while pertaining to the specific sheets they are placed on, also supplement the General Notes listed herein.
- F. The Contractor shall protect his workers at all times in conformance with applicable OSHA regulations.
- G. Whenever items in the Contract require materials to be removed and disposed, the cost of using an approved disposal area and transportation to the area shall be included in the unit price bid for those items.
- H. The Contractor is to visit the site before bidding, to become familiarized with the field conditions and to judge the extent and nature of the work to be done under the contract. No extra compensation will be allowed to the Contractor because of the Contractor's failure to include in his/her bid all items and materials which the Contractor is required to furnish in accordance with the Contract Documents. The Contractor must have in his/her possession a set of project plans and specifications for identification purposes when visiting the site.
- I. All dimensions and existing conditions shall be field verified by the Contractor.
- J. The Engineer will determine the location of the Contractor staging area based on available space and ongoing operations.

ITEM 627.0001 25**GENERAL REQUIREMENTS**

- K. The Contractor shall be responsible for restoring the site to its original condition unless indicated otherwise.

1.2 CODE COMPLIANCE AND STANDARDS

- A. All work described and to be performed under this Contract shall conform to the provisions outlined by 19 NYCRR, the New York State Uniform Fire Prevention and Building Code(s) and its reference standards.
- B. The Contractor shall comply with all applicable laws which pertain to the work to be done. The Contractor shall also comply with the owner's instructions and regulations pertaining to signs, advertising, fire and/or smoke.
- C. The Contractor shall obtain, maintain and pay for all permits, fees and licenses legally required and shall give all notices, and comply with all laws, rules and regulations applicable to the work.
- D. Where provisions of the pertinent codes, standards, regulations or Contract Documents conflict, the most stringent provision shall govern.

1.3 CONFINED SPACE ENTRY

- A. Contractor shall be solely responsible to comply with all regulations regarding worker safety, including confined space entry. Contractor to submit confined space plan to the Engineer for review and approval.

1.4 MATERIALS AND LABOR

- A. All materials, equipment and articles used permanently in the work which become the property of the Thruway Authority shall be new unless specifically stated otherwise.
- B. Whenever any product is specified by the name, trade name, make or catalog number or any manufacturer or supplier, the intent is not to limit competition but to establish a standard of quality which the Director has determined is necessary. The words "or equal" shall be deemed inserted in each instance. The Contractor may use any product equal to that named in the Contract Documents which is approved by the Engineer and which meets the requirements of the Contract Documents providing the Contractor gives timely notice of his intent in accordance with the submittal and scheduling requirements of the current versions of the NYSDOT's Standard Specifications, Section 100, and the NYS Thruway Authority Addendum.
- C. The Contractor shall have the burden of proving at his own cost and expense to the satisfaction of the Engineer that the proposed product is equal to the named product. The Engineer may establish criteria for product approval. The Director shall determine in his absolute discretion whether a proposed product is to be approved.
- D. If the Contractor fails to comply with these provisions, or if the Engineer determines that the proposed product is not equal to that named, the Contractor shall supply the product named.

ITEM 627.0001 25**GENERAL REQUIREMENTS**

- E. The Contractor shall have and make no claim for the extension of time or for damages because the Engineer requires a reasonable period of time to consider a product proposed by the Contractor or because the Engineer disapproves such a product.
- F. Where optional materials or methods are specified, or where “or equal” submissions are approved, the Contractor shall make all adjustments to contingent work necessary to accommodate the option he/she selects.
- G. **Royalties and Patents:** The Contractor shall pay all royalties and license fees. He shall defend all suits or claims for infringement of any patent rights and shall save the Thruway Authority harmless from loss on account thereof, except that the Thruway Authority shall be responsible for all such loss when a particular design, process or the product of a particular manufacturer or manufacturers is specified.

1.5 TOPOGRAPHIC SURVEY AND UTILITIES

- A. The location, nature, and alignment of underground utilities are based on utility evidence visible at the ground surface and are considered to be schematic only.
- B. Survey information does not claim to show all underground utilities, others may exist in the work area. Identification of all utilities within the work area shall be sole responsibility of the Contractor.
- C. The Contractor and subcontractors are directed to contact “**DIG SAFELY NEW YORK**” by calling 811 prior to starting work.
- D. The Contractor shall protect overhead and underground utilities to prevent damage or interruption of services. The Engineer and utility owner shall be notified if utility is disturbed. The cost of the cutting and restoring service or repair of any damage shall be borne by the Contractor.

1.6 USE OF PREMISES

- A. For the duration of the construction period, Contractor activities including the use of the site shall be coordinated so as to minimize interference with ongoing Thruway Authority, tenant, or other Contractors operations.
- B. All Contractor activities are subject to approval of the Engineer.
- C. Limit use of premises to work areas indicated. Do not disturb portions of site beyond areas in which the work is indicated.
- D. Keep driveways and entrances serving the premises clear and available to the Authority, other Contractors and emergency vehicles at all times. Do not use these areas for parking or storage of materials.
- E. Work hours shall be established by the Authority through the Engineer. The Contractor shall notify the Engineer of the intent to start work 48 hours in advance.

ITEM 627.0001 25**GENERAL REQUIREMENTS**

- F. Maintain existing building in weather tight condition throughout construction period. Repair damage caused by construction operations. Protect building and its occupants during the construction period
- G. The Contractor shall inform the Engineer of work area access requirements. The Engineer will coordinate and schedule access with Thruway Authority staff to obtain and ensure timely availability of work areas.
- H. Utility shutdowns shall be approved by the Engineer. Schedule interruptions with the Engineer for time and duration. Interruptions shall be limited to minimize impact on operations.
- I. Be responsible and accountable for employees, suppliers, subcontractors and their employees, with regard to their use of the premises. Direct them to comply with the Thruway Authority regulations and with the security and traffic regulations.
- J. Comply with applicable Federal and State of New York Right-To-Know Law provisions and supply copies of the appropriate safety data sheets (SDS) to the Engineer, and to the Thruway Authority's Right-To-Know information officer.
- K. Direct employees to be watchful for people in or near the work area where safety hazards may be present.
- L. Report fire and other emergency situations to the Engineer immediately.

1.7 STAGING AREA

- A. The Contractor shall limit the staging of materials to the work limits indicated, or as directed and defined at the Pre-Construction Meeting.

1.8 WORK ZONE TRAFFIC CONTROL

- A. Work Zone Traffic Control (WZTC) shall be complied with throughout the length and duration of the contract in accordance with the "Manual on Uniform Traffic Control Devices" and the Contract Documents.
- B. The cost of furnishing and installing all WZTC signs shall be paid for under Item 627.0001--25.
- C. **Protection of the Public:** The Contractor shall maintain and protect Authority traffic in accordance with the NYSDOT's Standard Specifications (current version) Section 619, the traffic control sheets and pertinent provisions of the Manual on Uniform Traffic Control Devices. The Contractor's attention is directed to the requirements of Section 107, legal relations and responsibility to the public, of the current version of the NYSDOT's Standard Specifications including current additions and modifications.

ITEM 627.0001 25**GENERAL REQUIREMENTS****1.9 RECONSTRUCTION NOTES**

- A. The Contractor shall examine and verify, in the field, all conditions and dimensions. Dimensions of the existing structures shown on these plans are for general reference only. They have been taken from the original construction or subsequent rehabilitation drawings and are not guaranteed. The Contractor shall take all such field measurements to assure proper fit of the finished work, and the Contractor shall assume full responsibility for their accuracy. If field conditions and dimensions differ from those shown on the plans, the Contractor shall use the field conditions and dimensions and make the appropriate changes to those shown on the plans, as approved by the Engineer. When shop drawings based on field measurements are submitted for approval, the field measurements made shall be indicated on the shop drawings submitted for reference of the reviewer.
- B. The Contractor's attention is directed to the fact that, due to the nature of reconstruction projects, the exact extent of reconstruction work cannot always be accurately determined prior to the commencement of work. These Contract Documents have been prepared based on field inspection and other information available at the time. Actual field conditions may require modifications to construction details and work quantities. The Contractor shall perform the work in accordance with field conditions and as approved by the Engineer.
- C. The Contractor will be held responsible for all damage to the existing facilities caused by his operations. All damage to the existing facilities which is not part of the intended work shall be repaired by the Contractor to the satisfaction of the Engineer without cost to the Authority.
- D. The Contractor shall limit his removal operations so as not to unduly disturb underlying materials which are to remain in place. The Contractor shall perform all work with care so that any materials which are to remain will not be damaged. If the Contractor damages any materials which are to remain in place, or which are to remain the property of the Authority, the damaged material shall be repaired or replaced in a manner satisfactory to the Engineer at the expense of the Contractor.

1.10 COORDINATION

- A. Schedule construction operations in the sequence best suited to accomplish the work especially where one part depends on the installation of the other.

1.11 REMOVAL & EXCAVATION NOTES

- A. The Contractor shall provide all temporary supports, bracing and other devices required or directed by the Engineer to protect the safety of the adjacent structures, roadway and utilities.
- B. The Contractor shall saw cut (straight line cuts) and remove existing asphalt concrete pavement and concrete where required for the installation of new work. Pavement and concrete shall be replaced in kind unless otherwise noted. Re-cut edges damaged by construction operations.

ITEM 627.0001 25**GENERAL REQUIREMENTS****1.12 SPOIL**

- A. The Contractor's attention is directed to the fact that no spoil area is available for this contract within the Thruway's Right-of-Way. All spoil shall be removed from the Thruway property and be lawfully disposed of by the Contractor. The Contractor shall comply with all local, state, and federal regulations that apply to the off-site disposal areas. All costs associated with the removal and lawful disposal of spoil materials shall be borne by the Contractor.

1.13 REINFORCEMENT NOTES

- A. All steel reinforcement used in concrete components shall be galvanized to a Class 1 level after fabrication in accordance with ASTM A767, zinc-coated (galvanized) steel bars for concrete reinforcement. Fabric reinforcement shall be galvanized in accordance with NYSDOT Spec. Subsection 719-01, Type 1. Exceptions to this requirement will be considered when the quantity of reinforcement is small as determined by the Engineer.

1.14 TRUSS NOTES

- A. The Contractor shall submit truss certificate(s) containing the seal and signature of a NYS Professional Engineer or Registered Architect, as provided for Sections 7307 and 7209 of the NYS Education Law and chapter 23 of the NYS Uniform Fire Prevention and Building Code.

1.15 PIPING

- A. Minimum cover over pipes shall be 4'-0", unless noted otherwise.
- B. Provide 5'-0" minimum clearance distance between water and sewer lines.
- C. **Utility Trenches:** Install continuous red metallic warning tape above piping, conduit, etc. The warning tape is to be installed 12" below finished grade.
- D. All vertical and horizontal bends may not be depicted on drawings.
- E. Provide all necessary fittings and adapters required to properly connect piping materials.

1.16 ELECTRICAL

- A. All electrical work associated and performed under this contract, shall meet the requirements outlined by NFPA 70 (NEC, National Electric Code) and NFPA 70E (Standard for Electrical Safety in the Workplace).
- B. Provide electrical inspection and report performed by third party inspection agency acceptable to the Authority and local area utility provider. The report shall certify that the installation is in accordance with the Contract Documents and applicable codes. The cost associated with the inspection and report shall be included in Item "627.0026--25".

ITEM 627.0001 25**GENERAL REQUIREMENTS**

- C. NFPA 70, Section 110.16; all switchboards, panelboards, control panels and motor control centers installed under this contract that will be subject to service and maintenance while energized shall be marked to warn of potential arc flash hazards and be labeled. Coordinate labeling with the Engineer prior to the time of final inspection.
- D. Panels are shown diagrammatically. Final positioning of panels to be approved by the Engineer.
- E. Conduits are shown diagrammatically. Exact runs shall be determined by the Contractor in the field, except where specially dimensioned on the plans. Final positioning of conduits runs to be approved by the Engineer.
- F. All exposed conduit shall be run parallel to the building walls and beams except as otherwise shown on the plans.
- G. All exposed conduit shall be supported by approved systems designed for the specific installation.
- H. Within an existing building where conduit is required to be run exposed, such conduit is to be run within 12” of the existing ceiling with vertical drops to electrical devices run tight to walls or as approved by the Engineer.
- I. Expansion fittings of the approved type shall be furnished and installed where conduits exposed or concealed pass through structural joints.
- J. Exact conduit stub-up locations are to be determined by the Contractor based on certified manufacturer’s drawings of respective equipment. Conduits shall be installed to agree with equipment furnished.
- K. Conduit for power, lighting and communication passing through concrete floors and walls from below grade, shall be installed with approved conduit sealing fittings.
- L. Underground electrical conduits that run under roadways and parking areas shall be schedule 80 PVC conduit unless noted otherwise.
- M. The Contractor shall furnish and install all electrical equipment required to provide complete and operational systems.

1.17 SHOP DRAWINGS AND SAMPLES

- A. Shop drawings include, but are not necessarily limited to, drawings, diagrams, illustrations, schedules, test data, performance charts, cuts, brochures, manufacturer’s product data, installation instructions, certifications, safety data sheet (SDS), sample product warranties, special warranties, maintenance data, color samples, and material samples, etc. This data will be prepared by the Contractor, subcontractor, manufacturer, supplier or distributor and submitted by the Contractor for approval by the Engineer.
- B. Samples are small physical pieces of actual materials submitted by the Contractor for review and approval by the Engineer.

ITEM 627.0001 25**GENERAL REQUIREMENTS**

- C. The Contractor and the Engineer shall adhere to the submittal and scheduling requirements for shop drawings and samples as set out in the current version of the NYS Thruway Authority Addendum.
- D. The Contractor shall review shop drawing and sample submittals, to the extent of their ability, for contract compliance before stamping as such and forwarding to the Engineer.
- E. By approving and submitting shop drawings and samples, the Contractor represents that he/she has determined and verified all field measurements, field construction criteria, materials, catalog numbers and similar data and that he/she has checked and coordinated each shop drawing and sample with the requirements of the Contract Documents.
- F. The Engineer's approval of shop drawings and samples shall not relieve the Contractor of responsibility for any deviation from the requirement of the Contract Documents unless the Contractor has informed the Engineer of the deviation in a separate writing at the time of submission and received written approval of the specific deviations. The Engineer's approval shall not relieve the Contractor from responsibility for errors or omissions in the shop drawings or samples.
- G. No portion of the work requiring a shop drawing or sample submission shall be commenced until the appropriate submission has been approved by the Engineer.
- H. Any portion of the work requiring shop drawings and samples shall be installed in accordance with the approved shop drawings and samples.
- I. **Substitutions:** Defined as changes in products, materials, equipment, and methods of construction from those required by the Contract Documents and proposed by the Contractor. Substitutions will not be considered during the bidding phase, but only after the project is awarded. Note, any product identified in the specifications with verbiage "**NO SUBSTITUTION ALLOWED**" means that this specific product is the standard of quality set by the Authority and as such "**OR EQUAL**" does not apply. Note, "I. Substitutions" is in addition to the current versions of the NYS Thruway Authority Addendum and NYSDOT's Standard Specifications, "Section 106 – Control of Material, 106-09 Equivalents".

1.18 INSPECTION FOR CONFORMANCE

- A. The Engineer will inspect and test the work at reasonable times at the site, unless the Engineer determines to make an inspection or test at the place of production, manufacturer or shipment. Such inspection or test shall be conclusive as to whether the material and workmanship inspected or tested conforms to the requirements of the contract. Such inspection or test shall not relieve the Contractor of responsibility for damage to or loss of the material prior to acceptance, nor in any way affect the continuing rights of the Engineer to reject the completed work.
- B. The Contractor shall furnish promptly without additional charge all facilities, labor and material reasonably needed to perform in a safe and convenient manner such inspection and test as the Engineer requires.

ITEM 627.0001 25**GENERAL REQUIREMENTS**

- C. The Contractor shall, without charge, promptly correct any work the Engineer finds does not conform to the Contract Documents unless in the Thruway Authority interest the Engineer consents to accept such work with an appropriate adjustment in the Contract price.
- D. If the Contractor does not promptly correct rejected work including the work of other Contractors destroyed or damaged by removal, replacement, or correction, the director may (1) correct such work and charge the cost thereof to the Contractor; or (2) terminate the contract in accordance with the current versions of the NYSDOT's Standard Specifications, Section 100, and the NYS Thruway Authority Addendum.
- E. The Contractor shall keep the Engineer informed of the progress of his work and particularly when he intends to cover work not yet inspected or tested. All inspection and tests by the Engineer shall be performed in such manner as not to unreasonably delay the work. The Contractor shall be charged with any additional cost of inspection when the work is not ready at the time specified by the Engineer for inspection.
- F. Should the Engineer determine at any time before acceptance of the entire work to examine work already completed by removing, uncovering or testing the same, the Contractor shall, on request, promptly furnish all necessary facilities, labor and materials to conduct such inspection, examination or test. If such work is found to be defective or nonconforming in any material respect, the Contractor shall defray all the expenses of such examination and satisfactory reconstruction. If the work is found to meet the requirements of the Contract Documents, the Engineer shall compensate the Contractor for the additional services involved in such examination and reconstruction and if completion of the work has been delayed hereby, he shall, in addition, grant the Contractor a suitable extension of time.
- G. No previous inspection or certificates of payment shall relieve the Contractor from the obligation to perform the work in accordance with the Contract Documents. The final payment shall not relieve the Contractor of the responsibility for failing to comply with the Contract Documents and he shall remedy all defects, paying the cost of any damage to other work resulting there from, which shall appear within a period of one (1) year from the date of "Acceptance" by the Director. The "Acceptance date" shall be determined at the "Joint Inspection" when all exception items have been complete to the satisfaction of the Engineer. See 1.19, Part C.
- H. Note all special inspections per Section 1704 of the NYS Uniform Fire Prevention and Building Code (19 NYCRR). Notify the Engineer when ready for such inspections.

1.19 CLOSEOUT PROCEDURES

- A. **Detailed Inspection:** The Engineer will advise the Contractor of the date and time of the detailed inspection (detailed inspection occurs when the Engineer determines the work to be substantially complete).
 - 1. The Contractor will have already performed the following and must provide items as listed at the start of the detailed inspection:
 - a. Deliver tools, spare parts, extra material, and similar items to a location designated by the Authority.
 - b. Label all panels, disconnects, equipment. Label type shall be approved by the Engineer prior to placing labels on the panels, equipment, etc.

ITEM 627.0001 25**GENERAL REQUIREMENTS**

- c. Make final change over of permanent locks and deliver keys to the Engineer. Advise the Engineer and Authority of change over in security provisions.
 - d. Complete start-up testing of systems.
 - e. Advise Engineer and Authority of change over in heat and other utilities.
 - f. Assemble two (2) complete sets of operation and maintenance data indicating the operation and maintenance of each system, subsystem, and piece of equipment not part of a system. Identify each binder (8 ½" x 11), on front and spine of each binder, with the printed title "Operation and Maintenance Instructions", title of project, and subject matter of binder when multiple binders are required. Include operation and maintenance data required in individual specification sections and as follows:
 - 1) **Operation Data:**
 - a) Emergency instructions and procedures.
 - b) System, subsystem, and equipment descriptions, including operating standards.
 - c) Operating procedures, including startup, shutdown, seasonal, and weekend operations.
 - d) Description of controls and sequence of operations.
 - e) Piping diagrams.
 - 2) **Maintenance Data:**
 - a) Manufacturer's information, including list of parts.
 - b) Name, address, and telephone number of installer or supplier.
 - c) Maintenance procedures.
 - d) Maintenance and service schedules for preventive and routine maintenance.
 - e) Maintenance record forms.
 - f) Sources of spare parts and maintenance materials.
 - g) Copies of maintenance service agreements.
 - h) Emergency instructions and procedures.
 - g. **Demonstration and Training:**
 - 1) Instruction: Instruct Authority's personnel to adjust, operate, and maintain systems, subsystems, and equipment not part of a system. Schedule the instruction sessions through the Engineer, and provide instructors experienced in operation and maintenance procedures. Include instruction for the following:
 - a) Review of documentation.
 - b) Operations.
 - c) Adjustments.
 - d) Troubleshooting.
 - e) Maintenance.
 - f) Repair.
2. The Contractor shall submit the following either prior too or at the start of the Detailed Inspection:
- a. List of items to be completed and corrected (Punch List).
 - b. Test/adjust/balance report/records.

B. Final Inspection: The Engineer will advise the Contractor of the date and time of the final inspection. A copy of the final inspection list containing all incomplete or unsatisfactory items

ITEM 627.0001 25**GENERAL REQUIREMENTS**

and the time allowed to complete the work will be furnished to the Contractor. The contractor shall complete the following at this time:

1. Complete final cleaning requirements, including touch-up painting.
2. Touch up and otherwise repair and restore marred exposed finishes.
 - a. **General:** Provide final cleaning. Conduct cleaning and waste-removal operations to comply with local laws and ordinances and federal and local environmental and anti-pollution regulations.
 - b. **Cleaning:** Employ experienced workers or professional cleaners for final cleaning. Clean each surface or unit to condition expected in an average commercial building cleaning and maintenance program. Comply with manufacturer's written instructions.
 - 1) Clean project site, yard, and grounds, in areas disturbed by construction activities, including landscape development areas, of rubbish, waste material, litter, and other foreign substances.
 - 2) Sweep paved areas broom clean.
 - 3) Rake grounds that are neither planted nor paved to a smooth, even-textured surface.
 - 4) Remove tools, construction equipment, machinery, and surplus material from project site.
 - 5) Complete removal of temporary facilities not already removed.
 - 6) Remove debris from limited access spaces, including roofs, plenums, shafts, equipment vaults, manholes, attics, and similar spaces.
 - 7) Vacuum carpet and similar soft surfaces.
 - 8) Clean mirrors and glass in doors and windows.
 - 9) Remove labels that are not permanent.
 - 10) Touch up and otherwise repair and restore marred, exposed finishes and surfaces. Replace finishes and surfaces that cannot be satisfactorily repaired or restored.
 - a) Do not paint over "UL" and similar labels, including mechanical and electrical nameplates.
 - 11) Wipe surfaces of mechanical and electrical equipment, and similar equipment. Remove excess lubrication, paint and mortar droppings, and other foreign substances.
 - 12) Clean plumbing fixtures to a sanitary condition, free of stains, including stains resulting from water exposure.
 - 13) Replace disposable air filters and clean permanent air filters. Clean exposed surfaces of diffusers, registers, and grills.
 - 14) Clean ducts, blowers, and coils.
 - 15) Clean light fixtures, lamps, globes, and reflectors to function with full efficiency. Replace burned-out bulbs, and those noticeably dimmed by hours of use, and defective and noisy starters in fluorescent and mercury vapor fixtures to comply with requirements for new fixtures.
3. Comply with safety standards for cleaning. Do not burn waste materials. Do not bury debris or excess materials on the Authority's property. Do not discharge volatile, harmful, or dangerous materials into drainage systems. Remove waste materials from project site and dispose of lawfully.

- C. **Joint Inspection:** The joint inspection for physical completion will be made by the Engineer accompanied by the Contractor and the representatives from the Authority to verify completion of

ITEM 627.0001 25**GENERAL REQUIREMENTS**

the exception items listed in the final inspection list. The verification of the completeness of all the exception items will enable the “Acceptance” by the Director, Department of Engineering. The purpose of having the “Acceptance Date” is to establish and record a date when all physical work of a contract is completed in accordance with contract requirements and to provide for the date of commencement of any guarantee period and a firm date in the consideration of the Liquidated Damages.

- D. Warranties and Bonds:** When the “Acceptance Date” has been establish, the Contractor shall submit specified warranties and bonds.
1. Assemble two (2) complete sets of warranties and bonds. Identify each binder (8 ½” x 11), on front and spine of each binder, with the printed title “Warranties and Bonds” and title of project. Include warranties and bonds data required in individual specification sections.

PART 2 - PART 2 – PRODUCTS (not used)

PART 3 - PART 3 – EXECUTION (not used)

END OF SECTION 010000

ITEM 627.0001 25**GENERAL REQUIREMENTS****SECTION 011000 – SUMMARY OF THE WORK****PART 1 - GENERAL****1.1 WORK COVERED BY CONTRACT DOCUMENTS****A. Project Identification:**

1. Project consists of a building Addition and Roof Replacement at the Weedsport Maintenance Section Building M3731, Milepost 304.2, in the New York Division of the New York State Thruway in Cayuga County.
2. Owner: New York State Thruway Authority.

The work consists of some asbestos abatement removal as per specifications. The removal in its entirety of the existing roof and roofing materials and associated amenities down to the existing concrete substrate as per the construction drawings. Installation of a new SBS roofing system and associated roofing amenities as per the construction drawings and the specifications. Construction of an addition onto the existing maintenance building, consisting of the demolition of an existing locker room and the addition of two expanded locker rooms and a break room.

1.2 CONTRACT

- A. Project will be constructed under a general construction contract.

1.3 PHYSICAL COMPLETION DATE

- A. Physically complete all the work for this contract on or before **November 8, 2024**.

1. The time allocated for the performance of work under this contract includes 10 days for notification of the Contractor of the Comptroller's approval of the Agreement.
2. The approval of the Agreement by the Comptroller constitutes the filing of the Contract Documents as a public record and notice to the Contractor that a fully executed contract exists between the Contractor and the New York State Thruway Authority.

1.4 SEQUENCE OF WORK

- A. Contractor shall prepare an initial schedule, outlining the proposed sequence of work, including work of subcontractors. The schedule shall reflect the timing of the approval manufacture and delivery of materials.
- B. Electrical Utility Power Interruptions: Sequence the Work to maintain power to at least a portion of the facilities and to keep the Project site open to the traveling public. Do not interrupt existing utilities serving facilities occupied by Owner or others unless permitted under the following conditions and then only after providing temporary power according to requirements indicated:
1. Schedule and coordinate the work with the local electric utility, project Engineer, Owner and affected section maintenance personnel.
 2. Utility power interruptions shall be pre-scheduled and limited to Tuesday, Wednesday or Thursday, 11:00 pm – 5:00 am, and shall last no longer than **4 hours**.

ITEM 627.0001 25**GENERAL REQUIREMENTS**

3. Obtain Engineer's, Owner's and affected section maintenance personnel written permission in advance (**not less than 5 business days**) of electrical utility power interruption.
4. After approval of the power interruption work period, notify Engineer, Owner and affected section maintenance personnel not less than **48 hours** in advance of work commencing.
5. Provide temporary facilities as required to maintain continuous power to at least a portion of the facility. At a minimum, the restrooms and water fountains must be available at all times.
6. The existing emergency generator can provide temporary power where needed. Generator start up shall be coordinated with Thruway Authority New York Division Facilities. Once the generator is running, safety precautions shall be taken when shutting down normal power and to prevent back feed into the main distribution switchboard (MDP).

1.5 COORDINATION WITH OCCUPANTS

- A. Occupancy: Owner, section maintenance personnel will occupy or use the Project site and existing buildings during the entire construction period. Cooperate with Owner and section maintenance personnel during construction to minimize conflicts and facilitate site use. Perform the Work so as not to interfere with day-to-day operations. Maintain existing exits unless otherwise indicated.
 1. Maintain access to existing walkways, corridors, and other adjacent occupied or used facilities. Do not close or obstruct walkways, corridors, or other occupied or used facilities without written permission from Owner and approval of affected restaurant/gas station operator or concessionaire.
 2. Notify Engineer, Owner and affected section maintenance personnel no less than **48 hours** in advance of activities that will affect operations.

B. PRODUCTS (Not Used)**PART 2 - EXECUTION (Not Used)****END OF SECTION 011000**

ITEM 627.0001 25**GENERAL REQUIREMENTS****SECTION 015000 - TEMPORARY FACILITIES AND CONTROLS****PART 1 - GENERAL****1.1 SUMMARY**

- A. This Section includes requirements for temporary facilities and controls, including temporary utilities, support facilities, and security and protection facilities.
- B. Temporary utilities include, but are not limited to, the following:
 - 1. Water service and distribution.
 - 2. Sanitary facilities, including toilets, wash facilities, and drinking-water facilities.
 - 3. Heating and cooling facilities.
 - 4. Ventilation.
 - 5. Electric power service.
 - 6. Lighting.
 - 7. Telephone service.
- C. Support facilities include, but are not limited to, the following:
 - 1. Project identification and temporary signs.
 - 2. Waste disposal facilities.
 - 3. Field offices.
 - 4. Storage and fabrication sheds.
 - 5. Lifts and hoists.
 - 6. Construction aids and miscellaneous services and facilities.
- D. Security and protection facilities include, but are not limited to, the following:
 - 1. Environmental protection.
 - 2. Tree and plant protection.
 - 3. Temporary fence.
 - 4. Security enclosure and lockup.
 - 5. Barricades, warning signs, and lights.
 - 6. Temporary enclosures.
 - 7. Fire protection.

1.2 DEFINITIONS

- A. Permanent Enclosure: As determined by the Engineer, permanent or temporary roofing is complete, insulated, and weather tight; exterior walls are insulated and weather tight; and all openings are closed with permanent construction or substantial temporary closures.

ITEM 627.0001 25 GENERAL REQUIREMENTS**1.3 USE CHARGES**

- A. General: Cost or use charges for temporary facilities are not chargeable to the Authority and shall be included in the Contract Sum.
- B. Water Service: Use water from the Authority's existing water system without metering and without payment of use charges.
- C. Electric Power Service: Use electric power from the Authority's existing system for the operation of tools and equipment determined by the Engineer to be standard for the work being done without metering and without payment of use charges.

1.4 INFORMATIONAL SUBMITTALS

- A. Site Plan: Show temporary facilities, utility hookups, staging areas, signage placement, barricades, temporary fencing and parking areas for construction personnel.

1.5 QUALITY ASSURANCE

- A. Standards: Comply with ANSI A10.6, NECA's "Temporary Electrical Facilities," and NFPA 241.
 - 1. Electric Service: Comply with NECA, NEMA, and UL standards and regulations for temporary electric service. Install service to comply with NFPA 70.
- B. Tests and Inspections: Arrange for authorities having jurisdiction to test and inspect each temporary utility before use. Obtain required certifications and permits.

1.6 PROJECT CONDITIONS

- A. Conditions of Use: The following conditions apply to use of temporary services and facilities by all parties engaged in the Work:
 - 1. Keep temporary services and facilities clean and neat.
 - 2. Relocate temporary services and facilities as required by progress of the Work.
- B. Accessible Temporary Egress: Comply with applicable provisions in the U.S. Architectural & Transportation Barriers Compliance Board's ADA-ABA Accessibility Guidelines.
- C. Warning Signs (Temporary):
 - 1. Work Zone Traffic Control (WZTC) shall be complied with throughout the length and duration of the contract in accordance with the "Manual on Uniform Traffic Control Devices" and the Contract Documents.
 - 2. The cost of furnishing and installing all WZTC signs shall be paid for under Item 627.0001—25 General Requirements.
- D. **Protection of the Public:** The Contractor shall maintain and protect Authority traffic in accordance with the NYSDOT's Standard Specifications (current version) Section 619, the traffic control sheets

ITEM 627.0001 25**GENERAL REQUIREMENTS**

and pertinent provisions of the Manual on Uniform Traffic Control Devices. The Contractor's attention is directed to the requirements of Section 107, legal relations and responsibility to the public, of the current version of the NYSDOT's Standard Specifications including current additions and modifications.

PART 2 - PRODUCTS**2.1 MATERIALS**

- A. General: Provide new materials. Undamaged, previously used materials in serviceable condition may be used if approved by the Engineer. Provide materials suitable for use intended.
- B. Chain-Link Fencing (Temporary):
 - 1. Minimum 2-inch, 0.148-inch- thick, galvanized steel, chain-link fabric fencing; minimum 6 feet high with galvanized steel pipe posts; minimum 2-3/8-inch- OD line posts and 2-7/8-inch- OD corner and pull posts, with 1-5/8-inch- OD top rails.
 - 2. Temporary Portable Chain-Link Fencing: Minimum 2-inch 9-gage, galvanized steel, chain-link fabric fencing; minimum 6 feet high with galvanized steel pipe posts; minimum 2-3/8-inch- OD line posts and 2-7/8-inch- OD corner and pull posts, with 1-5/8-inch- OD top and bottom rails. Provide concrete or galvanized steel bases for supporting posts.
- C. Heavy Duty Plastic Security Fencing: Conform to NYSDOT Standard Specification, Section 107-05, F, Restricted Areas
- D. Lumber and Plywood: Provide new materials as needed and required for temporary enclosures. Plywood, minimum 1/2 inch thick. Temporary framing shall be constructed of 2x dimensional lumber.
- E. Polyethylene Sheet: Reinforced, fire-resistive sheet, 10-mil minimum thickness, with flame-spread rating of 15 or less per ASTM E 84 and passing NFPA 701 Test Method 2.
- F. Tarpaulins: Fire-resistive labeled with flame-spread rating of 15 or less.
- G. Insulation: Un-faced mineral-fiber blanket, manufactured from glass, slag wool, or rock wool; with maximum flame-spread and smoke-developed indexes of 25 and 50, respectively.
- H. Water: Potable.

2.2 EQUIPMENT

- A. Fire Extinguishers: Hand carried, portable, UL rated. Provide class and extinguishing agent as indicated or a combination of extinguishers of NFPA-recommended classes for exposures.
 - 1. Comply with NFPA 10 and NFPA 241 for classification, extinguishing agent, and size required by location and class of fire exposure.
- B. Self-Contained Toilet Units: Single-occupant units of chemical, aerated re-circulation, or

ITEM 627.0001 25**GENERAL REQUIREMENTS**

- combustion type; vented; fully enclosed with a glass-fiber-reinforced polyester shell or similar nonabsorbent material.
- C. Electrical Outlets: Properly configured, NEMA-polarized outlets to prevent insertion of 110- to 120-V plugs into higher-voltage outlets; equipped with ground-fault circuit interrupters, reset button, and pilot light.
 - D. Drinking-Water Fixtures: Containerized, tap-dispenser, bottled-water drinking-water units, including paper cup supply.

PART 3 - EXECUTION**3.1 INSTALLATION, GENERAL**

- A. Locate facilities where they will serve Project adequately and result in minimum interference with performance of the Work. Relocate and modify facilities as required by progress of the Work.
- B. Provide each facility ready for use when needed to avoid delay. Maintain and modify as required. Do not remove until facilities are no longer needed or are replaced by authorized use of completed permanent facilities.

3.2 TEMPORARY UTILITY INSTALLATION

- A. General: Engage appropriate local utility company to install temporary service or connect to existing service. Where utility company provides only part of the service, provide the remainder with matching, compatible materials and equipment. Comply with utility company recommendations.
 - 1. Arrange with utility company, the Authority, and existing users for time when service can be interrupted, if necessary, to make connections for temporary services.
 - 2. Provide adequate capacity at each stage of construction. Before temporary utility is available, provide trucked-in services.
 - 3. Obtain easements to bring temporary utilities to Project site where the Authority's easements cannot be used for that purpose.
- B. Water Service: Use of the Authority's existing water service facilities will be permitted, as long as facilities are cleaned and maintained in a condition acceptable to the Authority. Prior to Final Completion, restore these facilities to condition existing before initial use.
 - 1. Provide rubber hoses as necessary to serve Project site.
- C. Sanitary Facilities: Use of the Authority's existing sanitary facilities will be permitted, as long as the Contractor's personnel do not track in dirt and debris from construction activities.
- D. Heating and Cooling: Provide temporary heating and cooling required by construction activities for curing or drying of completed installations or for protecting installed construction and existing facilities that are part of the work from adverse effects of low temperatures or high humidity. Select

ITEM 627.0001 25**GENERAL REQUIREMENTS**

equipment from that specified that will not have a harmful effect on completed installations or elements being installed.

- E. Ventilation and Humidity Control: Provide temporary ventilation required by construction activities for curing or drying of completed installations or for protecting installed construction and existing facilities that are part of the work from adverse effects of high humidity. Select equipment from that specified that will not have a harmful effect on completed installations or elements being installed. Coordinate ventilation requirements to produce ambient condition required and minimize energy consumption.
- F. Isolation of Work Areas in Occupied Facilities: Prevent dust, fumes, and odors from entering occupied areas.
- G. Electric Power Service: Use of the Authority's existing electric power service (110 to 120 V) will be permitted, as long as equipment is maintained in a condition acceptable to the Authority.
- H. Electric Distribution: Provide receptacle outlets adequate for connection of power tools and equipment.
 - 1. Provide waterproof connectors to connect separate lengths of electrical power cords if single lengths will not reach areas where construction activities are in progress. Do not exceed safe length-voltage ratio.
- I. Lighting: Provide temporary lighting with local switching that provides adequate illumination for construction operations.
- J. Telephone Service: Provide temporary telephone service throughout construction period for common-use facilities used by all personnel engaged in construction activities. Install separate telephone line for each field office.
 - 1. At each telephone, post a list of important telephone numbers.
 - a. Police and fire departments.
 - b. Ambulance service.
 - c. Contractor's home office.
 - d. Contractor's emergency after-hours telephone number.
 - e. Architect's office.
 - f. Engineers' offices.
 - g. Owner's office.
 - h. Principal subcontractors' field and home offices.
 - 2. Provide superintendent with cellular telephone or portable two-way radio for use when away from field office.

3.3 SUPPORT FACILITIES INSTALLATION

- A. General: Comply with the following:
 - 1. Locate field offices, storage sheds, and other temporary construction and support facilities for easy access.
 - 2. Maintain support facilities until Engineer requests removal.

ITEM 627.0001 25**GENERAL REQUIREMENTS**

- B. Temporary Signs: Prepare temporary signs in sizes indicated. Install temporary signs where approved by the Engineer to inform public and persons seeking entrance to facilities at the Project Site. Do not permit installation of unauthorized signs.
1. Construct signs of exterior-type Grade B-B high-density concrete form overlay plywood in sizes and thicknesses indicated. Support on posts or framing of preservative-treated wood or steel.
 2. Paint sign panel and applied graphics with exterior-grade alkyd gloss enamel over exterior primer.
 3. Maintain and touchup signs so they are legible at all times.
- C. Traffic Controls: Comply with requirements of authorities having jurisdiction.
1. Protect existing site improvements to remain including curbs, pavement, and utilities.
 2. Maintain access for fire-fighting equipment and access to fire hydrants.
- D. Parking: Use areas of Owner's existing parking areas for construction personnel.
- E. Waste Disposal Facilities: Provide waste-collection containers in sizes adequate to handle waste from construction operations. Containerize and clearly label hazardous, dangerous, or unsanitary waste materials separately from other waste.
1. If required by authorities having jurisdiction, provide separate containers, clearly labeled, for each type of waste material to be deposited.
- F. Contractor's Field Office: Provide an insulated, weather tight, air-conditioned field office for use by the contractor's field personnel engaged in construction activities at the Project site. Keep office clean and orderly.
- G. Storage and Fabrication Sheds: Provide sheds sized, furnished, and equipped to accommodate materials and equipment involved, including temporary utility services. Sheds may be open shelters or fully enclosed spaces within building or elsewhere on-site.
- H. Lifts and Hoists: Provide facilities for hoisting materials and personnel. Truck cranes and similar devices used for hoisting materials are considered "tools and equipment" and not temporary facilities.

3.4 SECURITY AND PROTECTION FACILITIES INSTALLATION

- A. Protection of Existing Facilities: Protect existing vegetation, equipment, structures, utilities, and other improvements at Project site and on adjacent properties, except those indicated to be removed or altered. Repair damage to existing vegetation, equipment, structures, utilities and other improvements at Project site and on adjacent properties.
- B. Environmental Protection: Provide protection, operate temporary facilities, and conduct construction in ways and by methods that comply with environmental regulations and that minimize possible air, waterway, and subsoil contamination or pollution or other undesirable effects. Avoid using tools and equipment that produce harmful noise. Restrict use of noisemaking tools and equipment to hours that will minimize complaints from persons or firms near Project site.
- C. Tree and Plant Protection: Install temporary fencing located as indicated or outside the drip line of

ITEM 627.0001 25**GENERAL REQUIREMENTS**

trees to protect vegetation from construction damage. Protect tree root systems from damage, flooding, and erosion.

D. Fencing (Temporary):

1. Chain-Link Fencing:

- a. Temporary Portable Chain-Link Fencing: Minimum 2-inch 9-gage, galvanized steel, chain-link fabric fencing; minimum 6 feet high with galvanized steel pipe posts; minimum 2-3/8-inch- OD line posts and 2-7/8-inch- OD corner and pull posts, with 1-5/8-inch- OD top and bottom rails. Provide concrete or galvanized steel bases for supporting posts.
- b. Before construction operations begin or when directed by engineer, install Chain-Link Fencing (Temporary) enclosure with lockable entrance gates to accommodate construction operations. Install in a manner that will prevent people, dogs, and other animals from easily entering site except by entrance gates.
- c. Provide gates in sizes and at locations necessary to accommodate needed access and construction operations.
- d. Maintain security by limiting number of keys and restricting distribution to authorized personnel. Provide Engineer and Authority with two set of keys.

2. Heavy Duty Plastic Security Fencing:

- a. Conform to NYSDOT Standard Specification, Section 107-05, F, Restricted Areas.
- b. Before construction operations begin or when directed by engineer, install Heavy Duty Plastic Security Fencing enclosure to accommodate construction operations. Install in a manner that will prevent people, dogs, and other animals from easily entering site.

E. Barricades, Warning Signs, and Lights: Comply with standards and code requirements for erecting structurally adequate barricades. Paint with appropriate colors, graphics, and warning signs to inform personnel and public of possible hazard. Where appropriate and needed, provide lighting, including flashing red or amber lights.

1. The placement of barricades for pedestrian and traffic safety shall be pre-approved by the Engineer. The Contractor shall submit to the Engineer, a plan showing the proposed barricade placement.

F. Temporary Enclosures: Provide temporary enclosures for protection of construction, in progress and completed, from exposure, foul weather, other construction operations, and similar activities. Provide temporary weather tight enclosure for building exterior.

1. Where heating or cooling is needed and permanent enclosure is not complete, provide insulated temporary enclosures. Coordinate enclosure with ventilating and material drying or curing requirements to avoid dangerous conditions and effects.
2. Vertical Openings: Close openings with plywood or similar materials.
3. Horizontal Openings: Close openings in floor or roof decks and horizontal surfaces with load-bearing, wood-framed construction.
4. Install tarpaulins securely using fire-retardant-treated wood framing and other materials.

G. Temporary Fire Protection: Install and maintain temporary fire-protection facilities of types needed to protect against reasonably predictable and controllable fire losses. Comply with NFPA 241.

ITEM 627.0001 25**GENERAL REQUIREMENTS**

1. Provide fire extinguishers, visible and accessible from space being served.
 - a. Field Offices: Class A stored-pressure water-type extinguishers.
 - b. Other Locations: Class ABC dry-chemical extinguishers or a combination of extinguishers of NFPA-recommended classes for exposures.
 - c. Locate fire extinguishers where convenient and effective for their intended purpose.
2. Store combustible materials in containers in fire-safe locations.
3. Maintain unobstructed access to fire extinguishers, fire hydrants, temporary fire-protection facilities, stairways, and other access routes for firefighting. Prohibit smoking in hazardous fire-exposure areas.
4. Supervise welding operations, combustion-type temporary heating units, and similar sources of fire ignition.

3.5 OPERATION, TERMINATION, AND REMOVAL

- A. Supervision: Enforce strict discipline in use of temporary facilities. To minimize waste and abuse, limit availability of temporary facilities to essential and intended uses.
- B. Maintenance: Maintain facilities in good operating condition until removal. Protect from damage caused by freezing temperatures and similar elements.
 1. Maintain operation of temporary enclosures, heating, cooling, humidity control, ventilation, and similar facilities on a 24-hour basis where required to achieve indicated results and to avoid possibility of damage.
- C. Termination and Removal: Remove each temporary facility when need for its service has ended, when it has been replaced by authorized use of a permanent facility, or no later than Substantial Completion. Complete or, if necessary, restore permanent construction that may have been delayed because of interference with temporary facility. Repair damaged Work, clean exposed surfaces, and replace construction that cannot be satisfactorily repaired.
 1. Materials and facilities that constitute temporary facilities are the property of Contractor.
 2. At Substantial Completion, clean and renovate permanent facilities used during construction period. Comply with final cleaning requirements in Division 1 Section 010000 – General Notes, "Closeout Procedures."

END OF SECTION 015000

ITEM 627.0003 25**CONCRETE****1. DESCRIPTION:**

- 1.01 Furnish all labor, materials, equipment and services necessary to complete the work as indicated on the Contract Plans and the attached Specification Summary.
- 1.02 All work shall conform to the requirements specified in Part 1 – General, of the Sections listed.

2. MATERIALS:

- 2.01 The materials shall be as specified in Part 2 – Products, of the Sections listed.

3. CONSTRUCTION DETAILS:

- 3.01 The construction details shall be as specified on Part 3 – Execution, if the Sections listed.

4. METHOD OF MEASUREMENT:

- 4.01 This item shall be measured for payment on a lump sum basis for the work completed in accordance with the Contract Documents and as directed by the Engineer.

5. BASIS OF PAYMENT:

- 5.01 Payment for this item shall be made at the lump sum bid price bid. The lump sum price bid shall include cost of furnishing all labor, material, equipment and appliances necessary to complete the work as indicated on the Contract Plans and as specified herein in the Sections listed.
- 5.02 Detailed Estimate:
 - A. Before the first certificate of payment is issued for the work under this item, submit a detailed estimate of quantities and prices for all materials, labor, and other items included under this item, which shall aggregate the contract lump sum price bid for this item. Prepare the detailed estimate in the same sequence as the Sections listed.
 - B. The detailed estimate shall be supported by such evidence, including certified copies of subcontracts, as the Engineer may require.
 - C. The detailed estimate must be approved by the Engineer who may revise it as, in his/her reasonable judgment, is necessary to make the various item conform to their true values. The value of each certificate of payment will be based on the approved detailed estimate.
- 5.03 Monthly payments will be made for this item in proportion to the total amount of work completed.

ITEM 627.0003 25**CONCRETE****1. SPECIFICATION SUMMARY**

1.01 This Item includes the following specifications:

- A. Section 030130 CONCRETE DECK REPAIR
- B. Section 031119 PERMANENT FORMS – ICF
- C. Section 033000 CAST-IN-PLACE CONCRETE

1.02 This item shall include, but not be limited to, the following:

- A. Repairing existing damaged concrete surfaces
- B. Detailing insulating concrete forms (ICFs) and cast-in-place concrete

Weedsport Addition to Maintenance Section and Roof Replacement, MP 304.2

SECTION 030130 - CONCRETE DECK REPAIR

PART 1 - GENERAL

1.1 GENERAL REQUIREMENTS

- A. All work shall conform to the latest industry practices and standards as applicable. Install all materials as per manufacturer's instructions.
- B. All work shall be performed by competent workmen trained and experienced in the particular type of work.
- C. Coordinate the work of this Section with other related Sections / Divisions.

1.2 SCOPE OF WORK

- A. The scope of work of this section includes repairing existing damaged concrete surfaces at roof deck at locations indicated on drawings and as directed by Authority's Representative. Work shall include but not necessarily limited to the following:
 - 1. Sounding of exposed concrete including cutting, chipping, and removing of deteriorated and unsound concrete.
 - 2. Proper surface preparation of the affected area in accordance with the instructions of the manufacturer of the repair material and as described in this section.
 - 3. Preparation of concrete surfaces and application of repair mortar in accordance with the instructions of the manufacturer of the repair material.

1.3 SUBMITTALS

- A. Product Data: Submit manufacturer's technical bulletins and MSDS on each product.
- B. Quality Control Submittals: Provide protection plan of surrounding areas and non-cementitious surfaces.

1.4 QUALITY ASSURANCE

- A. Qualifications:
 - 1. Manufacturer Qualifications: Company with minimum 10 years of experience in manufacturing of specified products and systems.
 - 2. Applicator Qualifications: Company with a minimum of 5 years' experience in application of specified products and systems on projects of similar size and scope, and is acceptable to product manufacturer.
- B. Mock-ups and testing concrete repairs:
 - 1. Furnish, build, and have tested a mock-up containing the contractor's proposed repair materials. A representative from the accepted repair material manufacturer shall be at the site during the placement of the repair material and the testing. Construct mock-up for

Weedspport Addition to Maintenance Section and Roof Replacement, MP 304.2

Authority's Representative visual examination, for quality control, and performance of required testing.

2. Tests shall be conducted by an Independent Testing laboratory, as accepted by Authority's Representative.
 3. Mock-up shall be constructed for patched repair at main roof decks, bulkhead roof decks, roof canopies and were directed by Authority's Representative.
 - a. Install at Project site or pre-selected area of building an area for mock-up as directed by Authority's Representative.
 - b. Apply material in strict accordance with manufacturer's written application instructions.
 - c. Manufacturer's representative or designated representative will review technical aspects, surface preparation, repair, and workmanship.
 - d. Mock-up will be standard for judging workmanship on remainder of Project.
 - e. Maintain mock-up during construction for workmanship comparison.
 - f. Do not alter, move, or destroy mock-up until Work is completed and approved by Authority's Representative.
 - g. Obtain Authority's Representative's written approval of mock-up before start of material application, including approval of aesthetics, color, texture, and appearance.
- C. Mock-up for patches shall be cured in accordance with manufacturer's recommendations. All mock-ups shall be tested for bond strength with the direct tension pull-off apparatus; "Bond Test" manufactured by German Instruments, Inc., Chicago, Illinois or equal.

1.5 DELIVERY, STORAGE, AND HANDLING

- A. Comply with manufacturer's ordering instructions and lead-time requirements to avoid construction delays.
- B. Deliver materials in manufacturer's original, unopened, undamaged containers with identification labels intact.
- C. Store tightly sealed materials off ground and away from moisture, direct sunlight, extreme heat, and freezing temperatures.

1.6 PROJECT CONDITIONS

- A. Environmental Requirements:
 1. Ensure that substrate surface and ambient air temperature are minimum of 45 degrees F and rising at application time and remain above 45 degrees F for at least 24 hours after application. Ensure that frost or frozen surfaces are thawed and dry.
 2. Do not apply material if snow, rain, fog, and mist are anticipated within 12 hours after application. Allow surfaces to attain temperature and conditions specified before proceeding with underlayment application.
 3. Do not apply over sealant joints, control joints, or other materials that will be affected by

Weedsport Addition to Maintenance Section and Roof Replacement, MP 304.2

solvent.

1.7 DEFICIENT WORK

- A. Where Work exhibits any one or more of the following deficiencies, or otherwise fails to conform to the Contract Documents and/or the Building Code, such Work shall be considered deficient and not in conformance with the requirements of the Contract:
1. Applied grout mix not as defined by this Specification.
 2. Spalling, honeycombing, and the like.
 3. Unauthorized cutting, chopping, construction joints, cold joints, and so forth.
 4. Workmanship not in accord with the Drawings, with this Specification, with accepted samples, or with referenced codes or standards.
 5. Improper surface preparation.
 6. Incorrect forming, cracking, surface defects, or improper consolidation.
 7. Excellence of tolerance, lack of alignment, and incorrect forming; and
 8. Evidence of freezing, improper curing and the like.
 9. Evidence of patching material failure.
- B. Where Authority's Representative, at his/her sole discretion, finds any of the above deficiencies or other work not in accord with the Drawings or with this Specification, Authority's Representative may order that the affected work be replaced or repaired at Contractor's expense. Further, contractor shall pay the fees of Testing Agency for the re-inspection and the re-testing of Work deemed defective by Authority's Representative.
- C. The cost of all other activities and procedures associated with defective Work shall be paid by Contractor.

PART 2 - PRODUCTS

2.1 APPLICATIONS/ SYSTEM

- A. Repairing Damaged Reinforced Structural Members:
1. Anti-corrosion cementitious coating for re-bars shall be epoxy modified cementitious products specifically formulated as a bonding agent and anti-corrosion coating. Bond strength (ASTM C882) shall be 2600 psi after 24 hours open time. Acceptable products:
 - Sika Armatec 110 Epocem. Sika Corporation, Lyndhurst, NJ, (800) 933- 7452.
 - EMACO P24 or Thoroc Rebar Primer 3 by BASF. Phone: 800-433-9517
 - or equal.
 2. Bonding agent to bond new patch material to old concrete:
 - Euco Epoxy 452 LV, Euclid Chemical Company, Cleveland, Ohio (216) 531-9222.
 - Sikadur 32 HI-Mod, Sika Corporation, Lyndhurst, New Jersey, (800) 933-7452.
 - or equal.
 3. Overhead and vertical repairs: polymer modified cementitious mortar shall be fast setting, non-sag and trowel grade. Acceptable polymer modified cementitious mortars:
 - Sonopatch by BASF. Phone: 800-433-9517
 - ThoRoc HB2 Repair Mortar by BASF. Phone: 800-433-9517
 - Emaco R320 by BASF. Phone: 800-433-9517

Weedspport Addition to Maintenance Section and Roof Replacement, MP 304.2

- or equal.
- B. Pins to be used in concrete surface repair shall be zinc coated ¼” dia x 3” long Hammer Drive Pins as manufactured by Power Fasteners Co. or equal. Length of pin shall be altered based on field condition.
- C. Hexagonal wire mesh shall be Stainless Steel wire mesh, 1” aperture and 23 gage as manufactured by Hebei FangZheng Wire Mesh Co. Ltd or equal.
- D. Curing compound shall be according to ACI 308 Standard Practice or Compliant with ASTM C309.
- E. Hooks to be ¼” dia. threaded stainless steel rods, 9” o.c. maximum set in epoxy adhesive.
- F. A minimum of ¾” cover shall be in place for all existing and new steel reinforcement.
- G. Substitutions: Products of equal quality and properties.
- H. Other manufacturers shall comply with minimum levels of material, color selection, and detailing indicated in Specifications or on Drawings. Authority’s Representative will be sole judge of appropriateness of substitutions.

PART 3 - EXECUTION

3.1 REPAIRS OF DETERIORATED CONCRETE AT ROOF DECK

- A. Surface Preparation
1. Protect adjacent Work areas and finish surfaces from damage during complete system application.
 2. Ensure area being repaired is structurally sound and fully cured.
 3. All repair procedures and work required to repair deteriorated concrete shall be included as part of this contract.
- B. Concrete Preparation:
1. First complete asbestos abatement; where applicable, as per applicable Sections of Division 2.
 2. Authority’s Representative will tap affected vertical face of slabs and shall mark hollow sounding deteriorated spalled or pre-spalled areas.
 3. Contractor shall mark a second line, outside, rectangular and not closer than 3” to first line. Saw cut ½” deep with a diamond saw equipped with HEPA vacuum dust collector along second line. Do not cut any reinforcing bars. Saw cut edges of repair areas to minimum depth of ½ inch to avoid featheredging and to provide square edge.
 4. All concrete shall be removed from within the marked boundary to a minimum depth of ¾ inch using chipping hammers equipped with chisel point bits. If delaminating exists beyond the minimum removal depth, then chipping shall continue until all unsound and delaminated concrete has been removed from the cavity.
 5. Where embedded reinforcement is exposed by concrete removal, extra caution shall be

Weedsport Addition to Maintenance Section and Roof Replacement, MP 304.2

exercised to avoid damaging the reinforcement during removal of additional unsound concrete. If bond between exposed embedded reinforcement and adjacent concrete is impaired by the Contractor's removal operations, then the contractor shall perform additional removal to sound concrete at no additional cost.

6. If rust layers are present on embedded reinforcement or steel shapes/anchors where it enters sound concrete, then additional removal of concrete along and beneath the reinforcement shall be done.
 7. After removals are complete, but prior to final cleaning, the cavity and all exposed reinforcement shall be inspected by Authority's Representative for compliance with the requirement of this section. Where Authority's Representative finds unsatisfactory cavity preparation, Authority's Representative shall re-inspect the areas after additional cavity preparation.
 8. Authority's Representative shall inspect all embedded reinforcement, within the cavity for defect due to corrosion or damage resulting from Contractor's removal operations. The assisting re-bars shall be provided to damage or defective bars as shown in the attached drawing details and as described below.
- C. Reinforcement, pins, and hooks in repair areas:
1. All embedded reinforcement exposed during deteriorated concrete removal that has lost the area as specified in the drawings and as determined by Authority's Representative, shall be considered defective. All non-defective exposed reinforcement that has lost section to the extent specified above as a direct result of contractor's removal operations shall be considered damaged.
 2. Supplement defective or damaged embedded reinforcement in accordance with the typical repair details shown on the drawings. Secure the new reinforcement to existing bars by wires or as directed by Authority's Representative.
 3. Loose reinforcement exposed during surface preparation shall be securely anchored with hooks to secure reinforcing prior to patch placement. This work is incidental to surface preparation and shall be included in the established unit price for the type of repair specified.
 4. Concrete shall be removed to provide a minimum of 1/2-inch clearance on all sides of reinforcement that is in place. A minimum of 3/4 inch concrete cover shall be provided over all new and existing reinforcement.
 5. All reinforcing steel that supplements defective or damaged reinforcing steel shall be installed with a minimum clear cover of 3/4 inches to repaired concrete surfaces and shall be prepared as required to meet the minimum clearance requirement and to match adjacent concrete surfaces.
 6. All exposed steel shall be cleaned of rust and laitance to bare metal by vacuum blasting in accordance with SSPC-SP6 "Commercial Blast Cleaning".
 7. Install stainless steel Hammer Drive pins and wire mesh at all repairs. Hammer Drive pins shall be installed using Hammer Drive Tool and by applying several sharp hammer blows to the tool. Minimum embedment shall be 1/2" in hard concrete. Use two pound hammer for maximum penetration using the fewest hammer blows. The spacing between pins shall be 12" o.c. and 4" from the edge of the cavity.
 8. Install stainless steel hooks with epoxy adhesive at repair area to secure existing reinforcing in place. Drill into sound substrate. Fill the hole with instantly mixed epoxy material using dispensing equipment and immediately install the hooks.

Weedsport Addition to Maintenance Section and Roof Replacement, MP 304.2

- D. Final preparation of cavity for repair:
1. Cavities shall be examined by the Authority's Representative prior to commencement of patching repair operations. Where Authority's Representative finds unsatisfactory cavity preparation, Authority's Representative shall direct the Contractor to perform additional work to obtain satisfactory cavity preparation.
 2. Cavities shall be completely power wire brushed with attached vacuum. Where power wire brush could not be performed, power wash shall be carried out. Pressure vacuuming cleaning with compressed air is required as a final step to remove dust and loose material. All debris shall be removed from the site prior to commencement of patching. Install stainless steel hooks 6" o.c. and assisting bars as determined by the Authority's Representative prior to patching.
 3. Cavities not inspected by the Authority's Representative prior to patch repair will be considered non-conforming and will be rejected. Repair material shall be removed, substrate shall be re-cleaned and repair material shall be reinstalled at no additional cost.
 4. Chipping hammer size shall be suitable to perform the required work without causing damage to structure.
 5. Clean surface by removing dust, unsound or contaminated material, oil, paint, greases, corrosion deposits, and all bond-inhibiting materials from surface.
 6. Contractor shall provide the means for dust and debris control.
 7. Do not use method of surface preparation that could damage concrete.
 8. Where breaking out is not required, roughen surface and remove laitance by mechanical means or high-pressure water wash. Remove oil and grease deposits by steam cleaning, detergent scrubbing, or degreasing. To ensure optimum results, test effectiveness of decontamination with pull-off test.
 9. Saturate surface with clean water. Surface should be saturated surface dry (SSD) with no standing water during application.
 10. For additional information on substrate preparation, refer to ICRI Guideline No. 03732 "Coatings and Polymer Overlays".
 11. Avoid contact with aluminum to prevent adverse chemical reaction and possible product failure. Insulate potential areas of contact by coating aluminum substrate with appropriate epoxy such as Sikadur Hi-Mod 32.
- E. Steel Preparation:
1. Remove oxidation and scale from exposed reinforcing steel per ICRI Technical Guideline No. 03730 "Guide to Surface Preparation for the Repair of Deteriorated Concrete Resulting from Reinforcing Steel Corrosion."
 2. To prevent future steel corrosion, coat prepared reinforcing steel with approved anticorrosion cementitious coating.
- F. Application of Repair Mortar
1. Ensure substrate is Saturated Surface-Dry (SSD).
 2. Using manufacturer's approved applicator, scrub thin coat thoroughly into surface to ensure sufficient bonding.
 3. Before bond coat dries, thoroughly compact repair mortar onto substrate and around exposed reinforcement.
 4. Install pins and wire mesh into repair mortar as per manufacturer's recommendations.

Weedspout Addition to Maintenance Section and Roof Replacement, MP 304.2

5. Scrub repair mortar into the substrate, filling all pores and voids. Force material against edge of repair, working towards center.
6. Where multiple lifts are used on repairs, lightly rake surface of initial application after initial set and before applying subsequent lifts. Allow preceding lift to reach final set, 30 minutes minimum. Before applying fresh material, saturate surface of lift with clean water.
7. If material sags during application, completely remove repair mortar, properly re-prime substrate, and reapply repair mortar at reduced thickness.
8. Finish repair mortar by striking off with straight edge and close with steel trowel. Wooden or plastic floats or sponges may also be used to achieve desired surface texture. Do not overwork completed surface.
9. Final finish surface shall match adjoining surface in texture, alignment, and flatness.

3.2 CURING

- A. Allow proper curing of patch repair mortar, conducted per ACI 308 "Standard Practice for Curing Concrete." Moist curing should commence immediately after finishing.
- B. Where ambient conditions (high temperature, low humidity, or moderate to high winds) may cause rapid moisture loss, use an ASTM C309-compliant compatible curing compound, sprayed onto surface of finished repair in continuous film. Curing compounds adversely affect the adhesion of following lifts of mortar or protective coating, pretesting of curing compound is recommended by the manufacturer. Do not use solvent based curing compound.

3.3 CLEANING

- A. Clean wet repair mortar material from tools and equipment with water. Remove cured materials mechanically.
- B. Clean up and properly dispose of debris remaining on Project site related to application.
- C. Remove temporary coverings and protection from adjacent Work areas.
- D. In case of spillage, scoop or vacuum into appropriate container, and dispose of in accordance with current applicable local, state, and federal regulations.

3.4 PROTECTION

- A. Protect repair mortar system and protective coating from damage during construction.
- B. Protect repair mortar system and protective coating from freezing for 24 hours after application.
- C. Protect surface prior to installation of finish topping from damage by use of plywood or other suitable protection course until Substantial Completion.

END OF SECTION 030130

TAS 24-9A D214913

Weedsport Addition to Maintenance Section and Roof Replacement, MP 304.2

SECTION 031119
PERMANENT FORMS—INSULATING CONCRETE FORMS

PART 1 - GENERAL

1.1 SUMMARY

- A. Supply and installation of permanent insulating concrete forms as formwork, placement of steel reinforcement and placement of concrete into formwork.

1.2 REFERENCES

- A. American Society for Testing and Materials (ASTM)
1. ASTM C 578 -- Standard Specification for Rigid, Cellular Polystyrene Thermal Insulation (ASTM C203, ASTM C303, ASTM C518, ASTM C272, ASTM D1621, ASTM D2126, ASTM D2863, ASTM E84, ASTM E96)
 2. ASTM C 236 -- Steady State Thermal Performance of Building Assemblies
 3. ASTM C 150 -- Standard Specification for Portland Cement Types I, II, III.
 4. ASTM D 1761 -- Standard Test Methods for Mechanical Fasteners in Wood
 5. ASTM E 84 -- Standard Test Method for Determining Surface Burning Characteristics of Building Materials
 7. ASTM A 615 -- Steel Specifications for Steel Reinforcement
 8. ASTM D 1929 -- Standard Test Method for Determining Ignition Properties of Plastics
 9. ASTM D 635 -- Rate of Burning and/or Extent and Time of Burning of Plastics in a Horizontal Position
 10. ASTM D 2843 -- Standard Test Method for Density of Smoke from the Burning or Decomposition of Plastics
 11. ASTM E 119 -- Fire Tests of Building Construction and Materials
 12. ASTM D 638 -- Standard Test Method for Tensile Properties of Plastics
 13. ASTM D732 -- Shear Strength of Plastics by Punch Tool
 14. ASTM E 90 -- Standard Test Method for Laboratory Measurement of Airborne Sound Transmission Loss of Building Partitions
 15. ASTM E2634 -- Standard Specification for Flat Wall Insulating Concrete Form Systems
- B. American Concrete Association
1. ACI 301 -- Standard Specification for Structural Concrete
 2. ACI 304 -- Guide for Measuring, Mixing, Transporting and Placing Concrete
 3. ACI 305 -- Hot Weather Concreting
 4. ACI 306 -- Cold Weather Concreting
 5. ACI 309 -- Guide for Consolidation of Concrete
 6. ACI 318 -- Building Code Requirements for Reinforced Concrete
 7. ACI 332 -- Guide to Residential Cast-In-Place Concrete Construction
 8. ACI 347 -- Guide to Formwork for Concrete
 9. ACI 560 -- Design and Construction with Insulating Concrete Forms
- C. International Code Council Evaluation Service, Inc. (ICC-ES)
1. AC 353 -- Acceptance Criteria for Stay-In-Place, Foam Plastic Insulating Concrete Forms
- D. Canadian Standards Association (CSA)
1. CAN/CSA A23.3 Design of Concrete Structures
- E. Underwriters Laboratory of Canada

Weedsport Addition to Maintenance Section and Roof Replacement, MP 304.2

1. CAN/ULC S701- Thermal Insulation, Polystyrene, Boards and Pipe Covering
2. CAN/ULC S102- Test for Surface Burning Characteristics of Building Materials and Assemblies
3. CAN/ULC S101- Fire Endurance Tests of Building Construction and Materials
4. CAN/ULC S717.1 – Standard for Flat Wall Insulating Concrete Form (ICF) Systems

1.3 SYSTEM DESCRIPTION - (ICF) Systems for Solid Concrete Walls

- A. Provide insulating concrete form product which has been manufactured and installed to withstand concrete placement loads without defects, damage, or failure and such that the cast-in-place concrete wall is designed according to ACI 318 “Building Code Requirements for Reinforced Concrete.” OR CAN/CSA A23.3 Design of Concrete Structures.
- B. Furnish labor, materials, equipment, and services necessary for the complete and proper installation of all insulating concrete framework and related work, as shown on the drawings or specified herein, in accordance with all applicable requirements of the contract documents.
 1. Insulating concrete wall formwork consisting of two flat wall panels of flame retardant Type II expanded polystyrene (EPS) manufactured to a 1.5 lbs/cu. ft. minimum density. The two EPS panels to be connected by 6 co-polymer polypropylene plastic tie inserts designed with cross members placed 8” o.c. horizontally and 8” o.c. vertically creating a symmetrical design enhancing installation efficiency and reducing product waste. Plastic tie inserts positioned perpendicular between the EPS panels. The ICF product to be modular or prefabricated factory assembled forms.
 2. The ICF formwork to have consistent 2 5/8” thick EPS panels with a single row of rectangular interlocking projections and recesses designed for efficient installation with the modular ICF formwork having no top, bottom, left or right sides; which is a universal type of design. Straight and specialty blocks (90-degree corner, 45-degree corner, etc.) all possess the same design features and characteristics.
 3. Plastic tie inserts designed to allow for additional reinforcement placement positions to comply with structural design. The rebar chair supports are two deep with a loose fit for contact splice connections.
 4. Wall system to provide a forming cavity width of a minimum 4”, 6”, 8”, 10” or 12” (as design requires). The cavity width shall be a consistent flat rectangular cross section for the full and half blocks.
 5. Wall system plastic tie inserts to provide minimum 1.5” wide and 0.23” thick
 6. fastening strips @ 8” o.c. fastening strips to be recessed beneath the EPS panel face 5/8” and run vertically full form height (16” for the standard Fox Block and 8” for the shorter Fox Half Block) to facilitate fastening both interior and exterior.
 7. Wall system consisting of two EPS panels, concrete and exterior and interior finishes to provide a minimum R22 insulation value.
 8. EPS foam to provide maximum vapor permeation of 3.5 Perm-in.
- C. Conform to the applicable building code requirements of regulatory agencies having jurisdiction.

1.4 SUBMITTALS

- A. All submittals, which do not conform to the following requirements, will not be acceptable:

Weedsport Addition to Maintenance Section and Roof Replacement, MP 304.2

- B. SUBMITTALS OF EQUALS. Submit insulating concrete form system to be considered as equal to the specified insulating concrete form system submitted and approved prior to bid date. Insulating concrete form system, which has been reviewed and accepted as equal to the specified form system, will be listed in an addendum prior to bid date; only then will equals be accepted at bidding. Submittals shall include the following;
1. A sample ICF formwork product to meet or exceed 1.4 System Description.
 2. Current edition of the insulating concrete form system manufacturer's specifications and installation guidelines.
 3. Documentation of the manufacturer's quality control/quality assurance program for the primary insulating concrete form product supplied.
 4. Descriptive list of the materials proposed for use.
 5. ICF manufactured product has been evaluated for current compliance with the applicable building code evaluation service.
 6. Documentation of fastener withdrawal from plastic tie insert flange strip.
 7. Documentation of fire rating design listings where applicable.
 8. Documentation of non-combustible construction approval where applicable.
 9. Letter from the proposed insulating concrete form system confirming that proposed insulating concrete form manufacturer had been producing ICF products in North America for a minimum of 5 years.
 10. Confirmation of third party Quality inspection of manufacturing location by either letter from an accredited third part inspection agency or submission of Quality Control Manual meeting ICC-ES requirements.
- C. SUBMITTALS PRIOR TO CONTRACT AWARD:
1. Proposed insulating concrete form manufacturer to submit product warranty prior to contract award.
- D. SUBMITTALS PRIOR TO COMMENCEMENT OF ICF WORK:
1. Designer's printed recommendations for the proper installation of mechanical and electrical component installations, penetrations, interior and exterior finishes and attachment of structural elements.

1.5 QUALITY ASSURANCE

- A. ACCEPTABLE PRODUCTS AND MANUFACTURER'S QUALIFICATIONS. A single manufacturer that has been continuously producing ICF products for not less than 5 years in North America.
- B. AGENCY APPROVALS. The proposed insulating concrete form product shall have been evaluated to the applicable building code and shown to be in current compliance as evidenced by an evaluation report and/or certification to a standard from one of the following code agencies.
1. ASTM E2634
 2. CAN/ULC S717.1
- C. Accredited third-party independent testing and current reporting.
- D. SCOPE OF WORK. The work to be performed under this specification shall include but is not limited to the following: Attend necessary job meetings and furnish competent and full time supervisor, labor, all materials, tools, and equipment necessary to complete, in an acceptable manner, the insulating concrete form system installation in accordance with

Weedsport Addition to Maintenance Section and Roof Replacement, MP 304.2

this specification. Comply with the application guidelines of the manufacturer of the insulating concrete form products.

- E. CONFERENCES: Subject to Architect's discretion.
1. PRELIMINARY CONFERENCE: As soon as possible after award of insulating concrete formwork, meet with the contractor, sub-contractors and other workers related with the installation of the insulating concrete form system including penetrating work and finish systems, architect, engineer, owner and representatives of other entities directly concerned with performance of the insulating concrete form system. Review requirements (Contract Documents), submittals, status of coordinating work, availability of materials, and installation facilities and establish preliminary installation schedule. Review requirements for inspections, testing, certifications, and forecaster weather conditions, governing regulations, insurance requirements and proposed installation procedure.
 2. PRE-APPLICATION INSULATING CONCRETE FORM CONFERENCE:
 - a. Approximately 2-3 weeks before scheduled commencement of insulating concrete form installation and associated work, meet at project site with contractor, sub-contractors, concrete supplier and other related work that must precede or follow formwork including architect, owner, insulating concrete form manufacturer's representative and other representatives directly concerned with performance of the work.
 - 1) Review methods and procedures related to insulating concrete formwork, including but not necessarily limited to the following:
 - 2) Verify that site conditions are as set out in Division 1 – General Requirements. Insulating concrete form installer is to coordinate provision of access, storage area and protection of ICF product.
 - 3) Verify footing installation conforms to requirements of ¼" within level and that steps or elevation changes in footings are in 8" or 16" height increments.
 - 4) Verify that reinforcing steel dowels are in place at specified centers along footing lengths.
 - 5) Review transitions, special penetration details, area drainage, curbs, proposed openings, structural elements (lintels and bucks) and conditions of other construction that will affect insulating concrete forms.
 - 6) Review insulating concrete form requirements (drawings, specifications, and other contract documents).
 - 7) Review required submittals, both completed and yet to be completed.
 - 8) Review and finalize construction schedule related to insulating concrete formwork and verify availability of materials, installer's personnel, equipment and facilities needed to make progress and avoid delays.
 - 9) Review temporary protection requirements for insulating concrete form system during and after installation.
 - 10) Review weather and forecasted weather conditions and procedures for coping with unfavorable conditions.

Weedsport Addition to Maintenance Section and Roof Replacement, MP 304.2

1.6 DELIVERY, STORAGE AND HANDLING

- A. Deliver products in original factory packaging, bearing listing and leveling identification of product, manufacturer and lot number. Installer to keep the labels for traceability of product for the duration of the contract.
- B. Handle and store products in a location to prevent damage and soiling.
- C. Ensure that UV protection is provided for material, on-site storage should be required for an extended time period.

1.7 PROJECT CONDITIONS

- A. Use appropriate measures for protection when required to ensure proper concrete curing conditions in accordance with ACI 305 and ACI 306 during periods of weather where temperatures are above or below minimum specified by the governing or local building code for concrete.
- B. Familiarize every member of the application crew with all applicable safety regulations recommended by OSHA and other industry or local governmental groups.

1.8 SEQUENCING AND SCHEDULING

- A. Sequence installation of insulating concrete forms with related work specified in other sections to ensure that wall assemblies, including window and door accessories, trim, service penetrations, transition changes and mechanical services are protected against damage from effects of weather, corrosion and adjacent construction activity.

1.9 PRODUCTS INSTALLED BUT NOT SPECIFIED OR SUPPLIED UNDER THIS SECTION

- A. Reinforcing Steel
- B. Concrete
- C. Anchor bolts, sleeves, embedments, and inserts
- D. Window and door bucks
- E. Damproofing, waterproofing, or parge coat
- F. Adequate bracing and scaffolding that meets the codes

1.10 WARRANTY

- A. Insulating concrete form manufacturer to provide copies of specified product warranties.

PART 2 - PRODUCTS**2.1 MANUFACTURER -- INSULATING CONCRETE FORM PRODUCTS**

Fox Blocks
6110 Abbott Drive
Omaha, NE 68110

Weedsport Addition to Maintenance Section and Roof Replacement, MP 304.2

www.foxblocks.com (877-369-2562)

Fox Blocks Technical Information and Training Guide is attached to this Section for Contractor's reference.

2.2 MATERIALS -- INSULATING CONCRETE FORM GENERAL CHARACTERISTICS: Form units with the following characteristics and dimensions to accommodate project criteria:

- A. Fox Blocks – pre-assembled modular block
- B. Fox Blocks Compact – field assembled block
- C. Fox Blocks Reveal – one-sided foam insulation block
- D. Expanded polystyrene (EPS) plastic foam units, each panel 2 5/8” thick.
- E. Full height web flanges 8 inches on center for fastening tested to ASTM D1761 and made from recycled polypropylene plastic
- F. Nominal 1.5 lbs./cu. ft. foam density.
- G. Form system to have smooth wall face on the interior cavity

2.3 BRACING, ALIGNMENT AND SCAFFOLD SYSTEM

- A. As an integral installation component of an insulating concrete form system, an adjustable metal scaffolding support and wall alignment system shall be provided.
- B. A device with adequate degrees of adjustment to ensure the completed insulating concrete form system walls are plumb after the placement and consolidation of concrete.
- C. An OSHA compliant scaffold support system to facilitate proper stacking of forms and placement of concrete and to handle all design construction loads.
- D. System adequate to reinforce and protect completed insulating concrete form installation prior to the attachment of structural elements to protect from wind damage.

2.4 CONCRETE

- A. Concrete supplied under Section 033000 shall be of strength as specified by the design engineer (measured at 28 days). The recommended aggregate size is 3/8” minimum and 3/4” maximum. Minimum compressive strength recommended is 3000 psi for the walls and 2500 psi for footing foundations per Engineer of Record.
- B. Recommended concrete slump is 5” to 7” and designed to be placed with a concrete pump.
- C. Perform the required concrete consolidation per ACI 304 and ACI 309 to be manufactured as specified or detailed by the structural engineer in conjunction with the insulating concrete form manufacturer's installation manual guidelines.
- D. In extreme temperatures concrete shall be placed in accordance with ACI 305 Cold Weather Concrete Placement or ACI 306 Hot Weather Concrete Placement

2.5 STEEL REINFORCEMENT

- A. Steel reinforcement shall be as designated on Structural Drawings (S-Series drawings) and shall be supplied in accordance with the Drawings for placement by the insulating concrete form installer.
- B. Lintel Description
- C. Lintels to be installed as specified or detailed by the structural engineer in conjunction with the insulating concrete form manufacturer's installation manual guidelines or per IRC/IBC or the NBC of Canada model codes. Size and placement of top and bottom reinforcing steel, stirrups for shear reinforcement and corner reinforcing to be verified with engineering design prior to concrete placement.
- D. xLerator Structural Steel reinforcement for the Corbel Ledge Form.
- E. Reinforcing steel stirrup to be placed in accordance with Structural Engineer's Specifications and details for the given project installation parameters.

2.6 PARGING

- A. Exposed exterior wall surface from 12 inches below grade to the bottom of the metal siding panels shall be covered with a durable, weather resistant covering. Product shall be a polymer-modified, fiber-reinforced, Portland cement based rigid coating formulated for use over EPS foam. Acceptable products include:
 - 1. Quikrete – "Foam Coating" (Product # 1219-81)

2.7 ACCESSORIES

- A. Window or Door Opening Buck Materials
 - 1. Extruded vinyl, wood, Fox Buck, or metal buck material.
- B. Steel Reinforcement for Corbel Ledge Form.
 - 1. xLerator – One-piece, one per form reinforcement supplied by Fox Blocks to be exclusively used in the Corbel Ledge Form

PART 3 - EXECUTION**3.1 PREPARATION**

- A. Remove all loose aggregate and foreign substances prior to commencement of insulating concrete form system installation.

3.2 INSTALLATION OF FORMWORK UNITS

- A. Installation of forms to be in accordance with manufacturer's installation guidelines as submitted in evidence under Article 1.5.
- B. The installer shall ensure the following accepted ICF construction practices are utilized on site as outlined in the manufacturer's installation guidelines:
 - 1. Footing Foundation Construction
 - 2. Staging Materials
 - 3. Wall Layout
 - 4. Course Placement

Weedspport Addition to Maintenance Section and Roof Replacement, MP 304.2

5. Horizontal Reinforcement Placement
6. Door and Window Opening Construction (See 3.4 Below)
7. Utility Service Penetration (See 3.3 Below)
8. Bracing, Alignment and Scaffolding
9. Vertical Reinforcement Placement
10. Lintel Construction (see applicable code and/or engineering design)
11. Checklist Prior to Concrete Placement
12. Concrete Placement
13. Placement Methods/Types (Pumping, etc.)
14. Mix Design
15. Concrete Consolidation Methods
16. Post Placement Methods
17. Below Grade Waterproofing Application
18. Parging/Exterior Finishes
19. Clean-up (See 3.5 Below)
20. Protection (See 3.6 Below)
21. Drainage tile
22. Backfilling

3.3 SERVICE PENETRATIONS

- A. Service penetrations (electrical service conduits, water service pipes, air supply, exhaust ducts, etc.) shall be placed at the required locations as indicated by the appropriate trades.
- B. Penetrations shall be reinforced as required by the structural engineer.
- C. Provide and install material such as metal and PVC Schedule 40 pipe sleeves at service penetrations prior to placing concrete to create voids where services can be passed through at a later date.

3.4 ACCESSORY PRODUCT INSTALLATIONS

- A. Buck Material. Refer to the manufacturer's guidelines for installation of appropriate bucking materials.
- B. xLerator steel reinforcement for use in the corbel block to be installed as specified or detailed by the structural engineer in conjunction with the insulating concrete form manufacturer's installation manual guidelines.

3.5 CLEANUP

- A. Clean up and properly dispose of all debris remaining on job site related to the installation of the insulating concrete forms.

3.6 PROTECTION

- A. Consult with exterior finish contractor concerning exposure to ultraviolet light to ensure proper finish to ICF walls.
- B. Protect the interlocking teeth prior to concrete placement if additional forms are to be stacked after concrete placement.

END OF SECTION 031119

SECTION 033000 - CAST-IN-PLACE CONCRETE

PART 1 - GENERAL

1.1 SUMMARY

- A. This Section specifies cast-in place concrete, including formwork, reinforcement, concrete materials, mixture design, placement procedures, finishes, and testing for the following:
1. Footings.
 2. Foundation walls.
 3. Slabs-on-grade.

1.2 DEFINITIONS

- A. Cementitious Materials: Portland cement alone or in combination with fly ash; subject to compliance with requirements.

1.3 SUBMITTALS

- A. Product Data: For each type of product indicated.
- B. Design Mixtures: For each concrete mixture, indicating quantity of each ingredient and admixtures proposed or required. Submit alternate design mixtures when characteristics of materials, Project conditions, weather, test results, or other circumstances warrant adjustments.
1. For mix designs based on field experience, include individual strength test results, standard deviation, and required average compressive strength calculations.
 2. For mix designs based on trial, include proportions, test results, and graphic analysis indicating average compressive strength.
 3. Indicate amounts of mixing water to be withheld for later addition at Project site.
- C. Steel Reinforcement Shop Drawings: Placing drawings that detail fabrication, bending, and placement. Include bar sizes, lengths, material, grade, bar schedules, stirrup spacing, bent bar diagrams, bar arrangement, splices and laps, mechanical connections, tie spacing, hoop spacing, and supports for concrete reinforcement.
- D. Schedule for Concrete Placement: Order-of-construction schedule by location in structure.
1. Include shop drawings indicating all construction joints required, including any anticipated joints due to placement schedule.
- E. Submit description of planned procedures and protective measures for cold weather or hot weather concreting.
- F. Qualification Data: For Installer.
- G. Material Test Reports: For the following, from a qualified testing agency, indicating compliance with requirements:
1. Aggregates. Include service record data indicating absence of deleterious expansion of concrete due to alkali aggregate reactivity.
- H. Material Certificates: For each of the following, signed by manufacturers; indicate compatibility with application of surface applied flooring products where applicable:
1. Cementitious materials.
 2. Aggregates.
 3. Admixtures.
 4. Form materials and form-release agents.
 5. Steel reinforcement and accessories.

Weedspport Addition to Maintenance Section and Roof Replacement, MP 304.2

- Curing compounds.
- 6. Bonding agents.
- 7. Adhesives.
- 8. Vapor retarders.
- 9. Joint-filler strips.
- 10. Repair materials.
- I. Floor surface flatness and levelness measurements to determine compliance with specified tolerances.
- J. Field quality-control test and inspection reports.
 - 1. Include copies of delivery tickets complying with ASTM C 94 for each load of concrete delivered to the site.
- K. Minutes of preinstallation conference.

1.4 QUALITY ASSURANCE

- A. Installer Qualifications: A qualified installer who employs on Project personnel qualified as ACI-certified Flatwork Technician and Finisher and a supervisor who is an ACI-certified Concrete Flatwork Technician.
- B. Manufacturer Qualifications: A firm experienced in manufacturing ready-mixed concrete products and that complies with ASTM C 94 requirements for production facilities and equipment.
 - 1. Comply with requirements of the Concrete Manufacturers Association "Concrete Plant Standards."
- C. Source Limitations: Obtain each type or class of cementitious material of the same brand from the same manufacturer's plant, obtain aggregate from one source, and obtain admixtures through one source from a single manufacturer.
- D. ACI Publications: Comply with the following unless modified by requirements in the Contract Documents:
 - 1. ACI 301, "Specification for Structural Concrete," Sections 1 through 5, Section 7, "Lightweight Concrete", and Section 8.
 - 2. ACI 117, "Specifications for Tolerances for Concrete Construction and Materials."
 - 3. ACI 305, "Hot Weather Concreting".
 - 4. ACI 306, "Cold Weather Concreting".
 - 5. ACI 308, "Guide to Curing Concrete".
 - 6. ACI 302, "Guide for Concrete Floor and Slab Construction".
 - 7. ACI 315 "Details and Detailing of Concrete Reinforcement."
 - 8. ACI 347 "Formwork for Concrete"; and
 - 9. Concrete Repair Manual, by ACI and ICRI.
- E. Concrete Testing Service: Engage a qualified independent testing agency to perform material evaluation tests and to design concrete mixtures.
- F. Preinstallation Conference: Conduct conference at Project site to comply with requirements in Division 01 Section "Project Management and Coordination."
 - 1. Before submitting design mixtures, review concrete design mixture and examine procedures for ensuring quality of concrete materials. Require representatives of each entity directly concerned with cast-in-place concrete to attend, including the following:
 - a. Contractor's superintendent.
 - b. Independent testing agency responsible for concrete design mixtures.

Weedsport Addition to Maintenance Section and Roof Replacement, MP 304.2

- c. Ready-mix concrete manufacturer.
- d. Concrete subcontractor.
- 2. Review the following:
 - a. Coordination with special inspection and testing and inspecting agency procedures for field quality control.
 - b. Concrete finishes and finishing.
 - c. Cold- and hot-weather concreting procedures.
 - d. Curing procedures.
 - e. Construction contraction and isolation joints and joint-filler strips.
 - f. Forms and form removal limitations.
 - g. Vapor-retarder installation.
 - h. Anchor rod and anchorage device installation tolerances.
 - i. Steel reinforcement installation.
 - j. Floor and slab flatness and levelness measurement.
 - k. Concrete repair procedures.
 - l. Concrete protection.

J. The Contractor is responsible for correction of concrete work which does not conform to the specified requirements, including strength, tolerances, and finishes. The Contractor shall correct deficient concrete as directed by the Architect.

1.5 DELIVERY, STORAGE, AND HANDLING

- A. Steel Reinforcement: Deliver, store, and handle steel reinforcement to prevent bending and damage.
 - 1. Store steel reinforcement off ground, under suitable cover or enclosed.
 - 2. Maintain ease of access for inspection and identification of materials.

PART 2 - PRODUCTS

2.1 FORM-FACING MATERIALS

- A. Smooth-Formed Finished Concrete: Form-facing panels that will provide continuous, true, and smooth concrete surfaces. Furnish in largest practicable sizes to minimize number of joints.
 - 1. Metal or other approved panel materials.
 - 2. Exterior-grade plywood panels, suitable for concrete forms, complying with DOC PS 1, and as follows:
 - a. High-density overlay, Class 1 or better.
 - b. Medium-density overlay, Class 1 or better; mill-release agent treated and edge sealed.
 - c. B-B (Concrete Form), Class 1 or better; mill oiled and edge sealed.
- B. Rough-Formed Finished Concrete: Plywood, lumber, metal, or another approved material. Provide lumber dressed on at least two edges and one side for tight fit.
- C. Chamfer Strips: Wood, metal, PVC, or rubber strips, 3/4 by 3/4 inch, minimum.
- D. Rustication Strips: Wood, metal, PVC, or rubber strips, kerfed for ease of form removal.
- E. Form-Release Agent: Commercially formulated form-release agent that will not bond with, stain, or adversely affect concrete surfaces and will not impair subsequent treatments of concrete surfaces.
 - 1. Formulate form-release agent with rust inhibitor for steel form-facing materials.

Weedsport Addition to Maintenance Section and Roof Replacement, MP 304.2

- F. Form Ties: Factory-fabricated, removable or snap-off metal or glass-fiber-reinforced plastic form ties designed to resist lateral pressure of fresh concrete on forms and to prevent spalling of concrete on removal.
1. Furnish units that will leave no corrodible metal closer than 1 inch to the plane of exposed concrete surface.
 2. Furnish ties that, when removed, will leave holes no larger than 1 inch in diameter in concrete surface.
 3. Furnish ties with integral water-barrier plates to walls indicated to receive dampproofing or waterproofing.

2.2 STEEL REINFORCEMENT

- A. Reinforcing Bars: ASTM A 615, Grade 60, deformed.
1. Include supplementary requirement S1.
- B. Plain-Steel Wire: ASTM A 82, as drawn.
- C. Plain-Steel Welded Wire Reinforcement: ASTM A 185, plain, fabricated from as-drawn steel wire into flat sheets.

2.3 REINFORCEMENT ACCESSORIES

- A. Joint Dowel Bars: ASTM A 615, Grade 60, plain-steel bars, cut bars true to length with ends square and free of burrs.
- B. Bar Supports: Bolsters, chairs, spacers, and other devices for spacing, supporting, and fastening reinforcing bars and welded wire reinforcement in place. Manufacture bar supports from steel wire, plastic, or precast concrete according to CRSI's "Manual of Standard Practice," of greater compressive strength than concrete and as follows:
1. For concrete surfaces exposed to view where legs of wire bar supports contact forms, use CRSI Class 1 plastic-protected steel wire or CRSI Class 2 stainless-steel bar supports.
 2. Supporting devices for slabs-on-grade shall have sand plates.
- C. Tie Wire: 16 gauge annealed type.

2.4 CONCRETE MATERIALS

- A. Cementitious Material: Use the following cementitious materials, of the same type, brand, and source, throughout Project:
1. Portland Cement: ASTM C 150, Type I or II. Supplement with the following:
 - a. Fly Ash: ASTM C 618, Class F.
- B. Aggregates, General: Tested and passed within 6 months of use for the following:
1. Gradation: ASTM C 136.
 2. Material Passing No. 200 Sieve: ASTM C 117.
 3. Organic Impurities: ASTM C 40.
 4. Soundness: ASTM C 88.
 5. Clay Lumps: ASTM C 142.
 6. Abrasiveness of Coarse Materials: ASTM C 131.
 7. Soft Particles: ASTM C 235.
 8. Freeze/Thaw Resistance: ASTM C 66, ASTM C 682.
- C. Normal-Weight Aggregates: ASTM C 33, Class 3S coarse aggregate or better, graded. Provide aggregates from a single source with documented service record data of at least 10 years'

Weedsport Addition to Maintenance Section and Roof Replacement, MP 304.2

satisfactory service in similar applications and service conditions using similar aggregates and cementitious materials.

1. Maximum Coarse-Aggregate Size:
 - a. Percentage passing No. 200 sieve shall be less than 0.7%.
 - b. Nominal size 1 1/2": ASTM Size No. 467.
 - c. Nominal size 1": ASTM Size No. 57.
 - d. Nominal size 1/2": ASTM Size No. 7.
2. Fine Aggregate: Free of materials with deleterious reactivity to alkali in cement.
 - a. Percentage passing No. 200 sieve shall be less than 3%.

D. Water: ASTM C 94 and potable.

2.5 ADMIXTURES

A. Air-Entraining Admixture: ASTM C 260.

B. Chemical Admixtures: Provide admixtures certified by manufacturer to be compatible with other admixtures and that will not contribute water-soluble chloride ions exceeding those permitted in hardened concrete. Do not use calcium chloride or admixtures containing calcium chloride. Admixtures which result in more than 0.1% of soluble chloride ions by weight of cement are prohibited.

1. Water-Reducing Admixture: ASTM C 494, Type A.
2. Retarding Admixture: ASTM C 494, Type B.
3. Water-Reducing and Retarding Admixture: ASTM C 494, Type D.
4. High-Range, Water-Reducing Admixture: ASTM C 494, Type F.
5. High-Range, Water-Reducing and Retarding Admixture: ASTM C 494, Type G.
6. Plasticizing and Retarding Admixture: ASTM C 1017, Type II.

C. Set-Accelerating Corrosion-Inhibiting Admixture: Commercially formulated, anodic inhibitor or mixed cathodic and anodic inhibitor; capable of forming a protective barrier and minimizing chloride reactions with steel reinforcement in concrete and complying with ASTM C 494, Type C.

1. Products:
 - a. Euclid Chemical Company (The); Eucon CIA.
 - b. Grace Construction Products, W. R. Grace & Co.; DCI.
 - c. Master Builders, Inc.; MasterLife CI 30.
 - d. Sika Corporation; Sika CNI.

2.6 VAPOR RETARDERS

A. Plastic Vapor Retarder: ASTM E 1745, Class A. Product shall have a permeance rating of 0.01 perms maximum. Include manufacturer's recommended adhesive or pressure-sensitive tape.

1. Products:
 - a. Fortifiber Corporation; Moistop Ultra A.
 - b. Raven Industries Inc.; Vapor Block 15.
 - c. Stego Industries, LLC; Stego Wrap, 15 mils.

B. Plastic Vapor Retarder: ASTM E 1745, Class B. Include manufacturer's recommended adhesive or pressure-sensitive tape.

1. Products:
 - a. Fortifiber Corporation; Moistop Ultra.
 - b. Raven Industries Inc.; Vapor Block 15.
 - c. Stego Industries, LLC; Stego Wrap, 15 mils.

Weedsport Addition to Maintenance Section and Roof Replacement, MP 304.2

- C. Granular Fill: Clean mixture of crushed stone or crushed or uncrushed gravel; ASTM D 448, Size 57, with 100 percent passing a 1-1/2-inch sieve and 0 to 5 percent passing a No. 8 sieve.
- D. Fine-Graded Granular Material: Clean mixture of crushed stone, crushed gravel, and manufactured or natural sand; ASTM D 448, Size 10, with 100 percent passing a 3/8-inch sieve, 10 to 30 percent passing a No. 100 sieve, and at least 5 percent passing No. 200 sieve; complying with deleterious substance limits of ASTM C 33 for fine aggregates.

2.7 CURING MATERIALS

- A. Evaporation Retarder: Waterborne, monomolecular film forming, manufactured for application to fresh concrete.
 - 1. Products:
 - a. Burke by Edoco; BurkeFilm.
 - b. ChemMasters; Spray-Film.
 - c. Meadows, W. R., Inc.; Sealtight Evapre.
 - d. Sika Corporation, Inc.; SikaFilm.
 - e. Symons Corporation, a Dayton Superior Company; Finishing Aid.
- B. Absorptive Cover: AASHTO M 182, Class 2, burlap cloth made from jute or kenaf, weighing approximately 9 oz./sq. yd. when dry.
- C. Moisture-Retaining Cover: ASTM C 171, polyethylene film or white burlap-polyethylene sheet.
- D. Water: Potable.
- E. Clear, Waterborne, Membrane-Forming Curing Compound: ASTM C 309, Type 1, Class B, 18 to 25 percent solids, nondissipating, certified by curing compound manufacturer to not interfere with bonding of floor covering.
 - 1. Characteristics: Acrylic polymer blend; non-yellowing from ultraviolet exposure; dustproofs concrete.
 - 2. Products:
 - a. ChemMasters; Safe-Cure Clear.
 - b. MBT Protection and Repair, Div. of ChemRex; MasterKure-N-Seal VOC.
 - c. Meadows, W. R., Inc.; Vocomp-20.
 - d. Sonneborn, Div. of ChemRex; Kure-N-Seal.
 - e. Symons Corporation, a Dayton Superior Company; Cure & Seal 18 Percent E.
 - f. Tamms Industries, Inc.; Clearseal WB STD.
- F. Clear, Solvent-Borne, Membrane-Forming Curing and Sealing Compound: ASTM C 1315, Type 1, Class A.
 - 1. Products:
 - a. Burke by Edoco; Cureseal 1315.
 - b. Euclid Chemical Company (The); Super Diamond Clear.
 - c. L&M Construction Chemicals, Inc.; Lumiseal Plus.
 - d. Meadows, W. R., Inc.; CS-309/30.
 - e. Sonneborn, Div. of ChemRex; Kure-N-Seal 5.
 - f. Tamms Industries, Inc.; LusterSeal 300.
- G. Evaporation Retarder:
 - Products:
 - a. BASF Construction Chemicals; Master Builders, Confilm.

Weedsport Addition to Maintenance Section and Roof Replacement, MP 304.2

2.8 RELATED MATERIALS

- A. Expansion-Joint-Filler and Isolation-Joint-Filler Strips: ASTM D 1751, asphalt-saturated cellulosic fiber for pavements and sidewalks, and ASTM D 1752, cork or self-expanding cork for slabs-on-grade.
- B. Preformed Control Joint Former for joints to receive sealant or for sawcut type joints. To be used only with approval of the Architect.
- C. Bonding Agent: ASTM C 1059, Type II, non-redispersible, acrylic emulsion or styrene butadiene.
- D. Burlap: AASHTO M 182, Class 2 jute or kenaf cloth.

2.9 REPAIR MATERIALS

- A. Repair Underlayment: Cement-based, polymer-modified, self-leveling product that can be applied in thicknesses from 1/8 inch and that can be feathered at edges to match adjacent floor elevations.
 - 1. Cement Binder: ASTM C 150, portland cement or hydraulic or blended hydraulic cement as defined in ASTM C 219.
 - 2. Primer: Product of underlayment manufacturer recommended for substrate, conditions, and application.
 - 3. Aggregate: Well-graded, washed gravel, 1/8 to 1/4 inch or coarse sand as recommended by underlayment manufacturer.
 - 4. Compressive Strength: Not less than 4100 psi at 28 days when tested according to ASTM C 109.

2.10 CONCRETE MIXTURES, GENERAL

- A. Prepare design mixtures for each type and strength of concrete, on the basis of laboratory trial mixture or field test data, or both, according to ACI 301. Proportion design mixes per the recommendations of ACI 211.1 for normal weight concrete.
 - 1. Use a qualified independent testing agency for preparing and reporting proposed mixture designs based on laboratory trial mixtures.
 - 2. Design mixes to meet or exceed each requirement specified. Adjust mix design to meet the most stringent requirement.
- B. Cementitious Materials: Limit percentage, by weight, of cementitious materials other than portland cement in concrete as follows:
 - 1. Fly Ash: 15 percent.
 - 2. Combined Fly Ash and Pozzolan: 15 percent.
- C. Limit water-soluble, chloride-ion content in hardened concrete to 0.06 percent by weight of cement.
- D. Admixtures: Use admixtures according to manufacturer's written instructions.
 - 1. Use water-reducing, high-range water-reducing or plasticizing admixture in concrete, as required, for placement and workability.
 - 2. Use water-reducing and retarding admixture when required by high temperatures, low humidity, or other adverse placement conditions.
 - 3. Use water-reducing admixture in pumped concrete, concrete for heavy-use industrial slabs and parking structure slabs, concrete required to be watertight, and concrete with a water-cementitious materials ratio below 0.50.
 - 4. Use set-accelerating corrosion-inhibiting admixture in concrete mixtures where indicated.

Weedsport Addition to Maintenance Section and Roof Replacement, MP 304.2

2.11 CONCRETE MIXTURES FOR BUILDING ELEMENTS

- A. Footings and Buried Foundations: Proportion normal-weight concrete mixture as follows:
1. Minimum Compressive Strength: 3,500 psi at 28 days.
 2. Maximum Water-Cementitious Materials Ratio by Weight: 0.50.
 3. Minimum Cementitious Materials Content: 475 lb/cu. yd.
 4. Maximum Nominal Aggregate Size: 1 inch.
 5. Maximum Slump Limit: 3-1/2 inches, plus or minus 1 inch.
- B. Slabs-on-Grade (Interior): Proportion normal-weight concrete mixture as follows:
1. Minimum Compressive Strength: 3000 psi at 28 days.
 2. Maximum Water-Cementitious Materials Ratio by Weight: 0.45.
 3. Minimum Cementitious Materials Content: 540 lb/cu. yd.
 4. Maximum Nominal Aggregate Size: 1 inch.
 5. Maximum Slump Limit: 3-1/2 inches, plus or minus 1 inch.
- C. Exposed Foundation, Exterior Walks and Retaining Walls: Proportion normal-weight concrete mixture as follows:
1. Minimum Compressive Strength: 5,000 psi at 28 days.
 2. Maximum Water-Cementitious Materials Ratio by Weight: 0.45.
 3. Minimum Cementitious Materials Content: 590 lb./cu.yd.
 4. Minimum Nominal Aggregate Size: 1/2 inch.
 5. Maximum Nominal Aggregate Size: 1-1/2 inches.
 6. Maximum Slump Limit: 3-1/2 inches, plus or minus 1 inch.
 7. Air Content: 5.5 percent, plus or minus 1.0 percent.
- D. Concrete Fill for Insulated Block Forms: Proportion normal-weight concrete mixture as follows:
1. Minimum Compressive Strength: 3,000 psi at 28 days.
 2. Maximum Water-Cementitious Materials Ratio by Weight: 0.45.
 3. Minimum Cementitious Materials Content: 590 lb./cu.yd.
 4. Maximum Nominal Aggregate Size: 3/8 inch to 3/4" max.
 5. Maximum Slump Limit: 5-7 inches, plus or minus 1 inch.
 6. Air Content: 4 to 6 percent.
- E. Controlled Low Strength Material (CLSM)
1. Permanent Material
 - a. Material shall meet the requirements of ACI 229R with a minimum compressive strength of 400 lb./sq. in.
 2. Removable Material
 - a. Material shall meet the requirements of ACI 229R with a minimum compressive strength of 50 to 100 lb./sq. in.

2.12 FABRICATING REINFORCEMENT

- A. Fabricate steel reinforcement according to CRSI's "Manual of Standard Practice."
- B. Bend steel reinforcement in accordance with ACI 318.
1. Do not heat steel reinforcement for bending. Bend or straighten bars cold.
 2. Do not bend partially embedded steel reinforcement, except as approved.

2.13 CONCRETE MIXING

- A. Ready-Mixed Concrete: Measure, batch, mix, and deliver concrete according to ASTM C 94, paragraphs 1 to 15 and 18 only, and furnish batch ticket information.

Weedspport Addition to Maintenance Section and Roof Replacement, MP 304.2

1. When air temperature is between 85 and 90 deg F, reduce mixing and delivery time from 1-1/2 hours to 75 minutes; when air temperature is above 90 deg F, reduce mixing and delivery time to 60 minutes.
2. Provide batch ticket for each batch discharged and used in the Work, indicating Project identification name and number, date, mixture type, mixture time, quantity, and amount of water added. Record approximate location of final deposit in structure.

PART 3 - EXECUTION

3.1 FORMWORK

- A. Design, erect, shore, brace, and maintain formwork, according to ACI 301, to support vertical, lateral, static, and dynamic loads, and construction loads that might be applied, until structure can support such loads.
- B.
 1. Where elevated concrete thickness exceeds 8 inches, contractor to provide Design Plans and Calculations of formwork shoring and bracing for review.
- C.
 2. Earth forms are not permitted.
- D. Construct formwork so concrete members and structures are of size, shape, alignment, elevation, and position indicated, within tolerance limits of ACI 117.
- E. Limit concrete surface irregularities, designated by ACI 347R as abrupt or gradual, as follows:
 1. Class A, 1/8 inch for smooth-formed finished surfaces.
 2. Class C, 1/2 inch for rough-formed finished surfaces.
- F. Construct forms tight enough to prevent loss of concrete mortar.
- G. Fabricate forms for easy removal without hammering or prying against concrete surfaces. Provide crush or wrecking plates where stripping may damage cast concrete surfaces. Provide top forms for inclined surfaces steeper than 1.5 horizontal to 1 vertical.
 1. Install keyways, recesses, and the like, for easy removal.
 2. Do not use rust-stained steel form-facing material.
- H. Set edge forms, bulkheads, and intermediate screed strips for slabs to achieve required elevations and slopes in finished concrete surfaces. Provide and secure units to support screed strips; use strike-off templates or compacting-type screeds.
- I. Provide temporary openings for cleanouts and inspection ports where interior area of formwork is inaccessible. Close openings with panels tightly fitted to forms and securely braced to prevent loss of concrete mortar. Locate temporary openings in forms at inconspicuous locations.
- J. Form openings, chases, offsets, sinkages, keyways, reglets, blocking, screeds, and bulkheads required in the Work. Determine sizes and locations from trades providing such items.
- K. Clean forms and adjacent surfaces to receive concrete. Remove chips, wood, sawdust, dirt, and other debris just before placing concrete.
- L. Retighten forms and bracing before placing concrete, as required, to prevent mortar leaks and maintain proper alignment.
- M. Coat contact surfaces of forms with form-release agent, according to manufacturer's written instructions, before placing reinforcement.

Weedspport Addition to Maintenance Section and Roof Replacement, MP 304.2

3.2 EMBEDDED ITEMS

- A. Place and secure anchorage devices and other embedded items required for adjoining work that is attached to or supported by cast-in-place concrete. Use setting drawings, templates, diagrams, instructions, and directions furnished with items to be embedded.
1. Install anchor rods, accurately located, to elevations required and complying with tolerances in Section 7.5 of AISC's "Code of Standard Practice for Steel Buildings and Bridges." Misplaced or damaged anchor rods will be subject to re-engineering fees.
 2. Install dovetail anchor slots in concrete structures as indicated.
 3. Installed penetrating conduits and embedded pipes in concrete shall comply with Section 6.3 of ACI 318.
 - a. No conduits or embedded pipes shall be located within supported slabs or slab-on-grade.

3.3 REMOVING AND REUSING FORMS

- A. General: Formwork for sides of beams, walls, columns, and similar parts of the Work that does not support weight of concrete may be removed after cumulatively curing at not less than 50 deg F for 24 hours after placing concrete, if concrete is hard enough to not be damaged by form-removal operations and curing and protection operations are maintained.
1. Leave formwork for beam soffits, joists, slabs, and other structural elements that supports weight of concrete in place until concrete has achieved at least 70 percent of its 28-day design compressive strength.
 2. Remove forms only if shores have been arranged to permit removal of forms without loosening or disturbing shores.
- B. Clean and repair surfaces of forms to be reused in the Work. Split, frayed, delaminated, or otherwise damaged form-facing material will not be acceptable for exposed surfaces. Apply new form-release agent.
- C. When forms are reused, clean surfaces, remove fins and laitance, and tighten to close joints. Align and secure joints to avoid offsets. Do not use patched forms for exposed concrete surfaces unless approved by Architect.

3.4 VAPOR RETARDERS

- A. Plastic Vapor Retarders: Place, protect, and repair vapor retarders according to ASTM E 1643 and manufacturer's written instructions.
1. Lap joints 6 inches and seal with manufacturer's recommended tape.

3.5 STEEL REINFORCEMENT

- A. General: Comply with CRSI's "Manual of Standard Practice" for placing reinforcement.
1. Do not cut or puncture vapor retarder. Repair damage and reseal vapor retarder before placing concrete.
 2. Allow six hours between completion of reinforcement installation and placement of concrete for special inspection.
- B. Clean reinforcement of dirt, grease, scale, loose rust, oil, paint and other foreign matter prior to installation.
- C. Accurately position, support, and secure reinforcement against displacement. Locate and support reinforcement with bar supports to maintain minimum concrete cover. Do not tack weld crossing reinforcing bars.
1. Weld reinforcing bars according to AWS D1.4, where indicated.

Weedsport Addition to Maintenance Section and Roof Replacement, MP 304.2

- D. Splicing and Embedment of Reinforcement: Conform to ACI 318 Chapter 12 for wired lap splices and embedment lengths.
- E. Set wire ties with ends directed into concrete, not toward exposed concrete surfaces.
- F. Install welded wire reinforcement in longest practicable lengths on bar supports spaced to minimize sagging. Lap edges and ends of adjoining sheets at least one mesh spacing. Offset laps of adjoining sheet widths to prevent continuous laps in either direction. Lace overlaps with wire.
- G. 1. "Hooking-up" or "Walking-in" of any reinforcement will not be permitted.
- H. Maintain required concrete cover dimensions indicated. Coordinate placement of conduit and inserts with reinforcement. Protect installed reinforcement from damage or displacement prior to and during concrete placement.
- I. 1. The Contractor shall repair or replace damaged, distorted, or displaced reinforcement.

3.6 JOINTS

- A. General: Construct joints true to line with faces perpendicular to surface plane of concrete.
- B. Construction Joints: Install so strength and appearance of concrete are not impaired, at locations indicated or as approved by Architect.
 - 1. Place joints perpendicular to main reinforcement. Continue reinforcement across construction joints, unless otherwise indicated. Do not continue reinforcement through sides of strip placements of floors and slabs.
 - 2. Form keyed joints as indicated. Embed keys at least 1-1/2 inches into concrete.
 - 3. Locate joints for beams, slabs, joists, and girders in the middle third of spans. Offset joints in girders a minimum distance of twice the beam width from a beam-girder intersection.
 - 4. Locate horizontal joints in walls and columns at underside of floors, slabs, beams, and girders and at the top of footings or floor slabs.
 - 5. Space vertical joints in walls as indicated. Locate joints beside piers integral with walls, near corners, and in concealed locations where possible.
 - 6. Use a bonding agent at locations where fresh concrete is placed against hardened or partially hardened concrete surfaces.
 - 7. Provide waterstops as indicated, and at all construction joints below grade adjacent to usable spaces.
- C. Contraction Joints in Slabs-on-Grade: Form weakened-plane contraction joints, sectioning concrete into areas as indicated. Construct contraction joints for a depth equal to at least one-fourth of concrete thickness or a minimum of 1-inch as follows:
 - 1. Grooved Joints: Form contraction joints after initial floating by grooving and finishing each edge of joint to a radius of 1/8 inch. Repeat grooving of contraction joints after applying surface finishes. Eliminate groover tool marks on concrete surfaces.
 - 2. Sawed Joints: Form contraction joints with power saws equipped with shatterproof abrasive or diamond-rimmed blades. Cut 1/8-inch-wide joints into concrete when cutting action will not tear, abrade, or otherwise damage surface and before concrete develops random contraction cracks.
 - 3. Spacing of joints shall not exceed 30 times (24 times for exposed concrete floor surface) the thickness of the slab nor 15 feet on center. All panels should be square or nearly so. Joints shall typically isolate columns and run between columns, with intermediate joints located at equal spaces between column lines.

Weedspport Addition to Maintenance Section and Roof Replacement, MP 304.2

4. Joints produced using conventional processes shall be made within 4 or 12 hours after the slab in that area has been finished- within 4 hours in hot weather and within 12 hours in cold weather.
 5. Joints produced using early-entry dry-cut saws shall be made within 1 or 4 hours after the slab in that area has been finished- within 1 hour in hot weather and within 4 hours in cold weather.
 6. Hand tooled joints shall be done immediately following edging, or at the same time.
 7. For floors to be covered with quarry tile, ceramic tile, or terrazzo, the joints shall be aligned with joints in the rigid floor coverings.
- D. Contraction Joints in Walls: Form weakened-plane contraction joints, sectioning concrete into areas as indicated. Provide adequate shear reinforcement as indicated or directed. Construct contraction joints as follows:
- E. 1. Joints shall be constructed to provide for the installation of watertight joint and sealant, and filled with sealant.
- F. 3. Spacing of joints shall be located about 4 feet from corners and intersections, and then at 25 feet on center thereafter.
- G. Isolation Joints in Slabs-on-Grade: After removing formwork, install joint-filler strips at slab junctions with vertical surfaces, such as column pedestals, foundation walls, grade beams, and other locations, as indicated.
1. Extend joint-filler strips full width and depth of joint, terminating flush with finished concrete surface, unless otherwise indicated.
 2. Terminate full-width joint-filler strips not less than 1/2 inch or more than 1 inch below finished concrete surface where joint sealants, specified in Division 07 Section "Joint Sealants," are indicated.
 3. Install joint-filler strips in lengths as long as practicable. Where more than one length is required, lace or clip sections together.
- H. Doweled Joints: Install dowel bars and support assemblies at joints where indicated. Lubricate or asphalt coat one-half of dowel length to prevent concrete bonding to one side of joint.

3.7 CONCRETE PLACEMENT

- A. Before placing concrete, verify that installation of formwork, reinforcement, and embedded items is complete and that required inspections have been performed and corrections made.
- B. Do not add water to concrete during delivery, at Project site, or during placement unless approved by Architect.
- C. Before test sampling and placing concrete, water may be added at Project site, subject to limitations of ACI 301.
1. Do not add water to concrete after adding high-range water-reducing admixtures to mixture.
- D. Deposit concrete continuously in one layer or in horizontal layers of such thickness that no new concrete will be placed on concrete that has hardened enough to cause seams or planes of weakness. If a section cannot be placed continuously, provide construction joints as indicated. Deposit concrete to avoid segregation.
1. Deposit concrete in horizontal layers of depth to not exceed formwork design pressures and in a manner to avoid inclined construction joints.
 2. Consolidate placed concrete with mechanical vibrating equipment according to ACI 301.

Weedsport Addition to Maintenance Section and Roof Replacement, MP 304.2

- a. Do not supplement mechanical consolidation by hand, spading, rodding, or tamping unless approved by Architect.
- 3. Do not use vibrators to transport concrete inside forms. Insert and withdraw vibrators vertically at uniformly spaced locations to rapidly penetrate placed layer and at least 6 inches into preceding layer. Do not insert vibrators into lower layers of concrete that have begun to lose plasticity. At each insertion, limit duration of vibration to time necessary to consolidate concrete and complete embedment of reinforcement and other embedded items without causing mixture constituents to segregate.
- E. Deposit and consolidate concrete slabs in a continuous operation, within limits of construction joints, until placement of a panel or section is complete.
 - 1. Consolidate concrete during placement operations so concrete is thoroughly worked around reinforcement and other embedded items and into corners.
 - 2. Maintain reinforcement in position on chairs during concrete placement.
 - 3. Screed slab surfaces with a straightedge and strike off to correct elevations.
 - 4. Slope surfaces uniformly to drains where required.
 - 5. Begin initial floating using bull floats or darbies to form a uniform and open-textured surface plane, before excess bleedwater appears on the surface. Do not further disturb slab surfaces before starting finishing operations.
- F. Provide sufficient time for excess water to evaporate prior to placement of floor coverings.
- G.
 - 1. Refer to floor covering product manufacturer submittals for requirements.
- H. Cold-Weather Placement: Comply with ACI 306 and as follows. Protect concrete work from physical damage or reduced strength that could be caused by frost, freezing actions, or low temperatures.
 - 1. When average high and low temperature is expected to fall below 40 deg F for three successive days, maintain delivered concrete mixture temperature within the temperature range required by ACI 301.
 - 2. Do not use frozen materials or materials containing ice or snow. Do not place concrete on frozen subgrade or on subgrade containing frozen materials.
 - 3. Do not use calcium chloride, salt, or other materials containing antifreeze agents or chemical accelerators unless otherwise specified and approved in mixture designs.
- I. Hot-Weather Placement: Comply with ACI 305 and as follows:
 - 1. Maintain concrete temperature below 90 deg F at time of placement. Chilled mixing water or chopped ice may be used to control temperature, provided water equivalent of ice is calculated to total amount of mixing water. Using liquid nitrogen to cool concrete is Contractor's option.
 - 2. Fog-spray forms, steel reinforcement, and subgrade just before placing concrete. Keep subgrade uniformly moist without standing water, soft spots, or dry areas.

3.8 FINISHING FORMED SURFACES

- A. Rough-Formed Finish: As-cast concrete texture imparted by form-facing material with tie holes and defects repaired and patched. Remove fins and other projections that exceed specified limits on formed-surface irregularities.
 - 1. Apply to concrete surfaces not exposed to public view.
- B. Smooth-Formed Finish: As-cast concrete texture imparted by form-facing material, arranged in an orderly and symmetrical manner with a minimum of seams. Repair and patch tie holes and defects. Remove fins and other projections that exceed specified limits on formed-surface irregularities.

Weedsport Addition to Maintenance Section and Roof Replacement, MP 304.2

1. Apply to concrete surfaces exposed to public view, to receive a rubbed finish, or to be covered with a coating or covering material applied directly to concrete.
- C. Related Unformed Surfaces: At tops of walls, horizontal offsets, and similar unformed surfaces adjacent to formed surfaces, strike off smooth and finish with a texture matching adjacent formed surfaces. Continue final surface treatment of formed surfaces uniformly across adjacent unformed surfaces, unless otherwise indicated.

3.9 FINISHING SLABS

- A. General: Comply with ACI 302.1R recommendations for screeding, restraighening, and finishing operations for concrete surfaces. Do not wet concrete surfaces.
- B. Trowel Finish: After applying float finish, apply first troweling and consolidate concrete by hand or power-driven trowel. Continue troweling passes and restraighen until surface is free of trowel marks and uniform in texture and appearance. Grind smooth any surface defects that would telegraph through applied coatings or floor coverings.
1. Apply a trowel finish to surfaces exposed to view or to be covered with resilient flooring, carpet, ceramic or quarry tile set over a cleavage membrane, paint, or another thin-film-finish coating system.
 2. Finish and measure surface so gap at any point between concrete surface and an unlevelled, freestanding, 10-foot-long straightedge resting on 2 high spots and placed anywhere on the surface does not exceed 1/8 inch.
- C. Trowel and Fine-Broom Finish: Apply a first trowel finish to surfaces where ceramic or quarry tile is to be installed by either thickset or thin-set method. While concrete is still plastic, slightly scarify surface with a fine broom.
1. Comply with flatness and levelness tolerances for trowel finished floor surfaces.
- D. Broom Finish: Apply a broom finish to exposed concrete platforms, steps, and ramps, and elsewhere as indicated.
1. Immediately after float finishing, slightly roughen trafficked surface by brooming with fiber-bristle broom perpendicular to main traffic route. Coordinate required final finish with Architect before application.

3.10 MISCELLANEOUS CONCRETE ITEMS

- A. Filling In: Fill in holes and openings left in concrete structures, unless otherwise indicated, after work of other trades is in place. Mix, place, and cure concrete, as specified, to blend with in-place construction. Provide other miscellaneous concrete filling indicated or required to complete the Work.
- B. Curbs: Provide monolithic finish to interior curbs by stripping forms while concrete is still green and by steel-troweling surfaces to a hard, dense finish with corners, intersections, and terminations slightly rounded.
- C. Equipment Bases and Foundations: Provide machine and equipment bases and foundations as shown on Drawings. Set anchor bolts for machines and equipment at correct elevations, complying with diagrams or templates from manufacturer furnishing machines and equipment. Misplaced or damaged anchor bolts will be subject to re-engineering fees.

Weedspport Addition to Maintenance Section and Roof Replacement, MP 304.2

3.11 CONCRETE PROTECTING AND CURING

- A. General: Protect freshly placed concrete from premature drying and excessive cold or hot temperatures. Comply with ACI 306 for cold-weather protection and ACI 305 for hot-weather protection during curing.
- B. Evaporation Retarder: Apply evaporation retarder to unformed concrete surfaces if hot, dry, or windy conditions cause moisture loss approaching 0.2 lb/sq. ft. x h before and during finishing operations. Apply according to manufacturer's written instructions after placing, screeding, and bull floating or darbying concrete, but before float finishing.
- C. Formed Surfaces: Cure formed concrete surfaces, including underside of beams, supported slabs, and other similar surfaces. If forms remain during curing period, moist cure after loosening forms. If removing forms before end of curing period, continue curing for the remainder of the curing period.
- D. Unformed Surfaces: Begin curing immediately after finishing concrete. Cure unformed surfaces, including floors and slabs, concrete floor toppings, and other surfaces.
- E. Cure concrete according to ACI 308.1, by one or a combination of the following methods:
 - 1. Moisture Curing: Keep surfaces continuously moist for not less than seven days with the following materials:
 - a. Water.
 - b. Continuous water-fog spray.
 - c. Absorptive cover, water saturated, and kept continuously wet. Cover concrete surfaces and edges with 12-inch lap over adjacent absorptive covers.
 - 2. Moisture-Retaining-Cover Curing: Cover concrete surfaces with moisture-retaining cover for curing concrete, placed in widest practicable width, with sides and ends lapped at least 12 inches, and sealed by waterproof tape or adhesive. Cure for not less than seven days. Immediately repair any holes or tears during curing period using cover material and waterproof tape.
 - a. Moisture cure or use moisture-retaining covers to cure concrete surfaces to receive penetrating liquid floor treatments as recommended by manufacturer.
 - b. Cure concrete surfaces to receive floor coverings with either a moisture-retaining cover or a curing compound that the manufacturer certifies will not interfere with bonding of floor coverings used on Project.
 - 3. Curing Compound: Apply uniformly in continuous operation by power spray or roller according to manufacturer's written instructions. Recoat areas subjected to heavy rainfall within three hours after initial application. Maintain continuity of coating and repair damage during curing period.
 - a. After curing period has elapsed, remove curing compound without damaging concrete surfaces by method recommended by curing compound manufacturer unless manufacturer certifies curing compound will not interfere with bonding of floor covering used on Project.
 - b. Curing compound to be applied only in locations permitted or required.
 - 4. Curing and Sealing Compound: Apply uniformly to floors and slabs indicated in a continuous operation by power spray or roller according to manufacturer's written instructions. Recoat areas subjected to heavy rainfall within three hours after initial application. Repeat process 24 hours later and apply a second coat. Maintain continuity of coating and repair damage during curing period.
 - a. Curing and sealing compound to be applied only in locations permitted or required.

Weedsport Addition to Maintenance Section and Roof Replacement, MP 304.2

3.12 JOINT FILLING

- A. Prepare, clean, and install joint filler according to manufacturer's written instructions.
 - 1. Defer joint filling until concrete has aged at least one month. Do not fill joints until construction traffic has permanently ceased.
- B. Remove dirt, debris, saw cuttings, curing compounds, and sealers from joints; leave contact faces of joint clean and dry.
- C. Install semirigid joint filler full depth in saw-cut joints and at least 2 inches deep in formed joints. Overfill joint and trim joint filler flush with top of joint after hardening.

3.13 CONCRETE SURFACE REPAIRS

- A. Defective Concrete: Repair and patch defective areas when approved by Architect. Remove and replace concrete that cannot be repaired and patched to Architect's approval.
- B. Patching Mortar: Mix dry-pack patching mortar, consisting of one part portland cement to two and one-half parts fine aggregate passing a No. 16 sieve, using only enough water for handling and placing.
- C. Repairing Formed Surfaces: Surface defects include color and texture irregularities, cracks, spalls, air bubbles, honeycombs, rock pockets, fins and other projections on the surface, and stains and other discolorations that cannot be removed by cleaning.
 - 1. Immediately after form removal, cut out honeycombs, rock pockets, and voids more than 1/2 inch in any dimension in solid concrete, but not less than 1 inch in depth. Make edges of cuts perpendicular to concrete surface. Clean, dampen with water, and brush-coat holes and voids with bonding agent. Fill and compact with patching mortar before bonding agent has dried. Fill form-tie voids with patching mortar or cone plugs secured in place with bonding agent.
 - 2. Repair defects on surfaces exposed to view by blending white portland cement and standard portland cement so that, when dry, patching mortar will match surrounding color. Patch a test area at inconspicuous locations to verify mixture and color match before proceeding with patching. Compact mortar in place and strike off slightly higher than surrounding surface.
 - 3. Repair defects on concealed formed surfaces that affect concrete's durability and structural performance as determined by Architect.
- D. Repairing Unformed Surfaces: Test unformed surfaces, such as floors and slabs, for finish and verify surface tolerances specified for each surface. Correct low and high areas. Test surfaces sloped to drain for trueness of slope and smoothness; use a sloped template.
 - 1. Repair finished surfaces containing defects. Surface defects include spalls, popouts, honeycombs, rock pockets, crazing and cracks in excess of 0.01 inch wide or that penetrate to reinforcement or completely through unreinforced sections regardless of width, and other objectionable conditions.
 - 2. After concrete has cured at least 14 days, correct high areas by grinding.
 - 3. Correct localized low areas during or immediately after completing surface finishing operations by cutting out low areas and replacing with patching mortar. Finish repaired areas to blend into adjacent concrete.
 - 4. Correct other low areas scheduled to receive floor coverings with a repair underlayment. Prepare, mix, and apply repair underlayment and primer according to manufacturer's written instructions to produce a smooth, uniform, plane, and level surface. Feather edges to match adjacent floor elevations.

Weedspport Addition to Maintenance Section and Roof Replacement, MP 304.2

5. Correct other low areas scheduled to remain exposed with a repair topping. Cut out low areas to ensure a minimum repair topping depth of 1/4 inch to match adjacent floor elevations. Prepare, mix, and apply repair topping and primer according to manufacturer's written instructions to produce a smooth, uniform, plane, and level surface.
 6. Repair defective areas, except random cracks and single holes 1 inch or less in diameter, by cutting out and replacing with fresh concrete. Remove defective areas with clean, square cuts and expose steel reinforcement with at least a 3/4-inch clearance all around. Dampen concrete surfaces in contact with patching concrete and apply bonding agent. Mix patching concrete of same materials and mixture as original concrete except without coarse aggregate. Place, compact, and finish to blend with adjacent finished concrete. Cure in same manner as adjacent concrete.
 7. Repair random cracks and single holes 1 inch or less in diameter with patching mortar. Groove top of cracks and cut out holes to sound concrete and clean off dust, dirt, and loose particles. Dampen cleaned concrete surfaces and apply bonding agent. Place patching mortar before bonding agent has dried. Compact patching mortar and finish to match adjacent concrete. Keep patched area continuously moist for at least 72 hours.
- E. Exposed reinforcing steel shall be mechanically cleaned using sandblasting or waterblasting methods. Reinforcing steel shall be free from rust, grease, or other bond-inhibiting coating.
- F. Repairs of depths greater than 3 inches are not covered by this specification. Notify Architect if such conditions are discovered for further direction of repair methods and products.
- G. Perform structural repairs of concrete, subject to Architect's approval, using epoxy adhesive and patching mortar.
- H. Repair materials and installation not specified above may be used, subject to Architect's approval.

3.14 FIELD QUALITY CONTROL

- A. Testing and Inspecting: Owner will engage a special inspector and qualified testing and inspecting agency to perform field tests and inspections and prepare test reports.
- B. Inspections:
1. Steel reinforcement placement.
 2. Verification of use of required design mixture.
 3. Concrete placement, including conveying and depositing.
 4. Curing procedures and maintenance of curing temperature.
- C. Concrete Tests: Testing of composite samples of fresh concrete obtained according to ASTM C 172 shall be performed according to the following requirements:
1. Testing Frequency: Obtain one composite sample for each day's pour of each concrete mixture exceeding 5 cu. yd., but less than 25 cu. yd., plus one set for each additional 50 cu. yd. or fraction thereof.
 2. Slump: ASTM C 143; one test at point of placement for each composite sample, but not less than one test for each day's pour of each concrete mixture. Perform additional tests when concrete consistency appears to change.
 3. Air Content: ASTM C 231, pressure method, for normal-weight concrete; ASTM C 173, volumetric method, for structural lightweight concrete; one test for each composite sample, but not less than one test for each day's pour of each concrete mixture.
 4. Concrete Temperature: ASTM C 1064; one test hourly when air temperature is 40 deg F and below and when 80 deg F and above, and one test for each composite sample.

Weedsport Addition to Maintenance Section and Roof Replacement, MP 304.2

5. Unit Weight: ASTM C 567, equilibrium unit weight of structural lightweight concrete; one test for each composite sample, but not less than one test for each day's pour of each concrete mixture.
 6. Compression Test Specimens: ASTM C 31.
 - a. Cast and laboratory cure two sets of two standard cylinder specimens for each composite sample.
 - b. Cast and field cure two sets of two standard cylinder specimens for each composite sample.
 7. Compressive-Strength Tests: ASTM C 39; test one set of two laboratory-cured specimens at 7 days and one set of two specimens at 28 days.
 - a. Test one set of two field-cured specimens at 7 days and one set of two specimens at 28 days.
 - b. A compressive-strength test shall be the average compressive strength from a set of two specimens obtained from same composite sample and tested at age indicated.
 8. When strength of field-cured cylinders is less than 85 percent of companion laboratory-cured cylinders, Contractor shall evaluate operations and provide corrective procedures for protecting and curing in-place concrete.
 9. Strength of each concrete mixture will be satisfactory if every average of any three consecutive compressive-strength tests equals or exceeds specified compressive strength and no compressive-strength test value falls below specified compressive strength by more than 500 psi.
 10. Test results shall be reported in writing to Architect, concrete manufacturer, and Contractor within 48 hours of testing. Reports of compressive-strength tests shall contain Project identification name and number, date of concrete placement, name of concrete testing and inspecting agency, location of concrete batch in Work, design compressive strength at 28 days, concrete mixture proportions and materials, compressive breaking strength, and type of break for both 7- and 28-day tests.
 11. Nondestructive Testing: Impact hammer, sonoscope, or other nondestructive device may be permitted by Architect but will not be used as sole basis for approval or rejection of concrete.
 12. Additional Tests: Testing and inspecting agency shall make additional tests of concrete when test results indicate that slump, air entrainment, compressive strengths, or other requirements have not been met, as directed by Architect. Testing and inspecting agency may conduct tests to determine adequacy of concrete by cored cylinders complying with ASTM C 42 or by other methods as directed by Architect.
 13. Additional testing and inspecting, at Contractor's expense, will be performed to determine compliance of replaced or additional work with specified requirements.
 14. Correct deficiencies in the Work that test reports and inspections indicate do not comply with the Contract Documents.
- D. Measure floor and slab flatness and levelness according to ASTM E 1155 within 72 hours of finishing.

END OF SECTION 033000

ITEM 627.0004 25**MASONRY****1. DESCRIPTION:**

- 1.01 Furnish all labor, materials, equipment and services necessary to complete the work as indicated on the Contract Plans and the attached Specification Summary.
- 1.02 All work shall conform to the requirements specified in Part 1 – General, of the Sections listed.

2. MATERIALS:

- 2.01 The materials shall be as specified in Part 2 – Products, of the Sections listed.

3. CONSTRUCTION DETAILS:

- 3.01 The construction details shall be as specified on Part 3 – Execution, if the Sections listed.

4. METHOD OF MEASUREMENT:

- 4.01 This item shall be measured for payment on a lump sum basis for the work completed in accordance with the Contract Documents and as directed by the Engineer.

5. BASIS OF PAYMENT:

- 5.01 Payment for this item shall be made at the lump sum bid price bid. The lump sum price bid shall include cost of furnishing all labor, material, equipment and appliances necessary to complete the work as indicated on the Contract Plans and as specified herein in the Sections listed.
- 5.02 Detailed Estimate:
 - A. Before the first certificate of payment is issued for the work under this item, submit a detailed estimate of quantities and prices for all materials, labor, and other items included under this item, which shall aggregate the contract lump sum price bid for this item. Prepare the detailed estimate in the same sequence as the Sections listed.
 - B. The detailed estimate shall be supported by such evidence, including certified copies of subcontracts, as the Engineer may require.
 - C. The detailed estimate must be approved by the Engineer who may revise it as, in his/her reasonable judgment, is necessary to make the various item conform to their true values. The value of each certificate of payment will be based on the approved detailed estimate.
- 5.03 Monthly payments will be made for this item in proportion to the total amount of work completed.

ITEM 627.0004 25**MASONRY****1. SPECIFICATION SUMMARY**

1.01 This Item includes the following specifications:

A. Section 042000 UNIT MASONRY

1.02 This item shall include, but not be limited to, the following:

A. Installation of new masonry units on the building's addition

SECTION 042000 - UNIT MASONRY

PART 1 - GENERAL

1.1 SUMMARY

- A. Section Includes:
1. Concrete masonry units.
 2. Concrete building brick.
 3. Face brick.
 4. Mortar and grout.
 5. Steel reinforcing bars.
 6. Masonry joint reinforcement.
 7. Ties and anchors.
 8. Embedded flashing.
 9. Miscellaneous masonry accessories.
 10. Cavity-wall insulation.

1.2 DEFINITIONS

- A. CMU(s): Concrete masonry unit(s).
- B. Reinforced Masonry: Masonry containing reinforcing steel in grouted cells.

1.3 SUBMITTALS

- A. Product Data: For each type of product indicated.
- B. Shop Drawings: For the following:
1. Reinforcing Steel: Detail bending and placement of unit masonry reinforcing bars. Comply with ACI 315, "Details and Detailing of Concrete Reinforcement." Show elevations of reinforced walls.
- C. Qualification Data: For testing agency.
- D. Material Certificates: For each type and size of the following:
1. Masonry units.
 2. Cementitious materials. Include brand, type, and name of manufacturer.
 3. Grout mixes. Include description of type and proportions of ingredients.
 4. Reinforcing bars.
 5. Joint reinforcement.
 6. Anchors, ties, and metal accessories.
- E. Mix Designs: For each type of mortar and grout. Include description of type and proportions of ingredients.
- F. Statement of Compressive Strength of Masonry: For each combination of masonry unit type and mortar type, provide statement of average net-area compressive strength of masonry units, mortar type, and resulting net-area compressive strength of masonry determined according to Tables 1 and 2 in ACI 530.1/ASCE 6/TMS 602.
- G. Cold-Weather and Hot-Weather Procedures: Detailed description of methods, materials, and equipment to be used to comply with requirements.

Weedsport Addition to Maintenance Section and Roof Replacement, MP 304.2

1.4 QUALITY ASSURANCE

- A. Source Limitations for Masonry Units: Obtain exposed masonry units of a uniform texture and color, or a uniform blend within the ranges accepted for these characteristics, from single source from single manufacturer for each product required.
- B. Source Limitations for Mortar Materials: Obtain mortar ingredients of a uniform quality, including color for exposed masonry, from single manufacturer for each cementitious component and from single source or producer for each aggregate.
- C. Masonry Standard: Comply with ACI 530.1/ASCE 6/TMS 602 unless modified by requirements in the Contract Documents.
- D. Installer Qualifications: The masonry installation contractor shall provide qualified installers. The International Masonry Institute (IMI) provides training and technical services to contractors will come to the job site to train masons in flashing fundamentals. Each employee shall receive this training prior to performing work on this project.
- E. Preinstallation Conference: Conduct conference at Project site.

1.5 DELIVERY, STORAGE, AND HANDLING

- A. Store masonry units on elevated platforms in a dry location. If units are not stored in an enclosed location, cover tops and sides of stacks with waterproof sheeting, securely tied. If units become wet, do not install until they are dry.
- B. Store cementitious materials on elevated platforms, under cover, and in a dry location. Do not use cementitious materials that have become damp.
- C. Store aggregates where grading and other required characteristics can be maintained and contamination avoided.
- D. Store masonry accessories, including metal items, to prevent corrosion and accumulation of dirt and oil.

1.6 PROJECT CONDITIONS

- A. Protection of Masonry: During construction, cover tops of walls, projections, and sills with waterproof sheeting at end of each day's work. Cover partially completed masonry when construction is not in progress.
 - 1. Extend cover a minimum of 24 inches down both sides of walls and hold cover securely in place.
 - 2. Where one wythe of multi-wythe masonry walls is completed in advance of other wythes, secure cover a minimum of 24 inches down face next to unconstructed wythe and hold cover in place.
- B. Do not apply uniform floor or roof loads for at least 12 hours and concentrated loads for at least three days after building masonry walls or columns.
- C. Stain Prevention: Prevent grout, mortar, and soil from staining the face of masonry to be left exposed or painted. Immediately remove grout, mortar, and soil that come in contact with such masonry.
 - 1. Protect base of walls from rain-splashed mud and from mortar splatter by spreading coverings on ground and over wall surface.
 - 2. Protect sills, ledges, and projections from mortar droppings.

Weedsport Addition to Maintenance Section and Roof Replacement, MP 304.2

3. Protect surfaces of window and door frames, as well as similar products with painted and integral finishes, from mortar droppings.
 4. Turn scaffold boards near the wall on edge at the end of each day to prevent rain from splashing mortar and dirt onto completed masonry.
- D. Cold-Weather Requirements: Do not use frozen materials or materials mixed or coated with ice or frost. Do not build on frozen substrates. Remove and replace unit masonry damaged by frost or by freezing conditions. Comply with cold-weather construction requirements contained in ACI 530.1/ASCE 6/TMS 602.
1. Cold-Weather Cleaning: Use liquid cleaning methods only when air temperature is 40 deg F and higher and will remain so until masonry has dried, but not less than seven days after completing cleaning.
- E. Hot-Weather Requirements: Comply with hot-weather construction requirements contained in ACI 530.1/ASCE 6/TMS 602.

PART 2 - PRODUCTS

2.1 MASONRY UNITS, GENERAL

- A. Defective Units: Referenced masonry unit standards may allow a certain percentage of units to contain chips, cracks, or other defects exceeding limits stated in the standard. Do not use units where such defects will be exposed in the completed Work.
- B. Fire-Resistance Ratings: Where indicated, provide units that comply with requirements for fire-resistance ratings indicated as determined by testing according to ASTM E 119, by equivalent masonry thickness, or by other means, as acceptable to authorities having jurisdiction.

2.2 CONCRETE MASONRY UNITS

- A. Shapes: Provide shapes indicated and as follows, with exposed surfaces matching exposed faces of adjacent units unless otherwise indicated.
1. Provide special shapes for lintels, corners, jambs, sashes, movement joints, headers, bonding, and other special conditions.
 2. Provide bullnose units for outside corners unless otherwise indicated.
- B. CMUs: ASTM C 90.
1. Density Classification: Lightweight unless otherwise indicated.
 2. Size (Width): Manufactured to dimensions 3/8 inch less than nominal dimensions.
 3. Exposed Faces: Provide color and texture matching the range represented by Architect's sample.
 4. Faces to Receive Plaster: Where units are indicated to receive a direct application of plaster, provide textured-face units made with gap-graded aggregates.
- C. Concrete Building Brick: ASTM C 55.
1. Density Classification: Lightweight.

2.3 BRICK

- A. General: Provide shapes indicated and as follows, with exposed surfaces matching finish and color of exposed faces of adjacent units:
1. For ends of sills and caps and for similar applications that would otherwise expose unfinished brick surfaces, provide units without cores or frogs and with exposed surfaces finished.

Weedsport Addition to Maintenance Section and Roof Replacement, MP 304.2

2. Provide special shapes for applications where stretcher units cannot accommodate special conditions, including those at corners, movement joints, bond beams, sashes, and lintels.
 3. Provide special shapes for applications requiring brick of size, form, color, and texture on exposed surfaces that cannot be produced by sawing.
 4. Provide special shapes for applications where shapes produced by sawing would result in sawed surfaces being exposed to view.
- B. Face Brick: Facing brick complying with ASTM C 216.
1. Where shown to "match existing," provide face brick matching color range, texture, and size of existing adjacent brickwork.

2.4 MORTAR AND GROUT MATERIALS

- A. Portland Cement: ASTM C 150, Type I or II, except Type III may be used for cold-weather construction. Provide natural color or white cement as required to produce mortar color indicated.
- B. Hydrated Lime: ASTM C 207, Type S.
- C. Portland Cement-Lime Mix: Packaged blend of portland cement and hydrated lime containing no other ingredients.
- D. Mortar Pigments: Natural and synthetic iron oxides and chromium oxides, compounded for use in mortar mixes and complying with ASTM C 979. Use only pigments with a record of satisfactory performance in masonry mortar.
1. Products: Subject to compliance with requirements, provide one of the following:
 - a. Davis Colors; True Tone Mortar Colors.
 - b. Lanxess Corporation; Bayferrox Iron Oxide Pigments.
 - c. Solomon Colors, Inc.; SGS Mortar Colors.
- E. Aggregate for Mortar: ASTM C 144.
1. For mortar that is exposed to view, use washed aggregate consisting of natural sand or crushed stone.
 2. For joints less than 1/4 inch thick, use aggregate graded with 100 percent passing the No. 16 sieve.
 3. White-Mortar Aggregates: Natural white sand or crushed white stone.
 4. Colored-Mortar Aggregates: Natural sand or crushed stone of color necessary to produce required mortar color.
- F. Aggregate for Grout: ASTM C 404.
- G. Water: Potable.

2.5 REINFORCEMENT

- A. Uncoated Steel Reinforcing Bars: ASTM A 615 or ASTM A 996, Grade 60.
- B. Masonry Joint Reinforcement, General: ASTM A 951.
1. Interior Walls: Mill-galvanized, carbon steel.
 2. Exterior Walls: Hot-dip galvanized, carbon steel.
 3. Wire Size for Side Rods: 0.148-inch diameter.
 4. Wire Size for Cross Rods: 0.148-inch diameter.
 5. Wire Size for Veneer Ties: 0.148-inch diameter.
 6. Spacing of Cross Rods, Tabs, and Cross Ties: Not more than 16 inches o.c.
 7. Provide in lengths of not less than 10 feet.

Weedsport Addition to Maintenance Section and Roof Replacement, MP 304.2

- C. Masonry Joint Reinforcement for Single-Wythe Masonry: Either ladder or truss type with single pair of side rods.
- D. Masonry Joint Reinforcement for Multiwythe Masonry:
 1. Adjustable (two-piece) type, either ladder or truss design, with one side rod at each face shell of backing wythe and with separate adjustable ties with pintle-and-eye connections having a maximum adjustment of 1-1/4 inches. Size ties to extend at least halfway through facing wythe but with at least 5/8-inch cover on outside face.

2.6 TIES AND ANCHORS

- A. Materials: Provide ties and anchors specified in this article that are made from materials that comply with the following unless otherwise indicated.
 1. Mill-Galvanized, Carbon-Steel Wire: ASTM A 82; with ASTM A 641, Class 1 coating.
 2. Hot-Dip Galvanized, Carbon-Steel Wire: ASTM A 82; with ASTM A 153, Class B-2 coating.
 3. Steel Sheet, Galvanized after Fabrication: ASTM A 1008, Commercial Steel, with ASTM A 153, Class B coating.
 4. Steel Plates, Shapes, and Bars: ASTM A 36.
- B. Corrugated Metal Ties: Metal strips not less than 7/8 inch wide with corrugations having a wavelength of 7.6 to 12.7 mm and an amplitude of 0.06 to 0.10 inch made from 0.030-inch-thick, steel sheet, galvanized after fabrication.
- C. Adjustable Anchors for Connecting to Structural Steel Framing: Provide anchors that allow vertical or horizontal adjustment but resist tension and compression forces perpendicular to plane of wall.
 1. Anchor Section for Welding to Steel Frame: Crimped 1/4-inch-diameter, stainless-steel wire.
 2. Tie Section: Triangular-shaped wire tie, sized to extend within 1 inch of masonry face, made from 0.25-inch-diameter, stainless-steel wire.
- D. Adjustable Anchors for Connecting to Concrete: Provide anchors that allow vertical or horizontal adjustment but resist tension and compression forces perpendicular to plane of wall.
- E. Partition Top anchors: 0.105-inch-thick metal plate with 3/8-inch-diameter metal rod 6 inches long welded to plate and with closed-end plastic tube fitted over rod that allows rod to move in and out of tube. Fabricate from steel, hot-dip galvanized after fabrication.
- F. Adjustable Masonry-Veneer Anchors:
 1. General: Provide anchors that allow vertical adjustment but resist tension and compression forces perpendicular to plane of wall, for attachment over sheathing to wood or metal studs, and as follows:
 - a. Structural Performance Characteristics: Capable of withstanding a 100-lbf load in both tension and compression without deforming or developing play in excess of 0.05 inch.
 2. Contractor's Option: Unless otherwise indicated, provide any of the following types of anchors:
 3. Screw-Attached, Masonry-Veneer Anchors: Units consisting of a wire tie and a metal anchor section.
 - a. Products: Subject to compliance with requirements, provide one of the following:
 - 1) Dayton Superior Corporation, Dur-O-Wal Division; D/A 213 or D/A 210 with D/A 700-708.

Weedsport Addition to Maintenance Section and Roof Replacement, MP 304.2

- 2) Heckmann Building Products Inc.; 315-D with 316 or Pos-I-Tie.
- 3) Hohmann & Barnard, Inc.; DW-10, DW-10HS or DW-10-X.
- 4) Wire-Bond; 1004, Type III or RJ-711.
- b. Fabricate sheet metal anchor sections and other sheet metal parts from 0.075-inch-thick, steel sheet, galvanized after fabrication.
- c. Wire Ties: Triangular-, rectangular-, or T-shaped wire ties fabricated from 0.187-inch-diameter, hot-dip galvanized steel wire.
4. Polymer-Coated, Steel Drill Screws for Steel Studs: ASTM C 954 except manufactured with hex washer head and neoprene or EPDM washer, No. 10 diameter by length required to penetrate steel stud flange with not less than three exposed threads, and with organic polymer coating with salt-spray resistance to red rust of more than 800 hours per ASTM B 117.
 - a. Products: Subject to compliance with requirements, provide one of the following:
 - 1) ITW Buildex; Teks Maxiseal with Climaseal finish.
 - 2) Textron Inc., Textron Fastening Systems; Elco Dril-Flex with Stalgard finish.
5. Stainless-Steel Drill Screws for Steel Studs: Proprietary fastener consisting of carbon-steel drill point and 300 Series stainless-steel shank, complying with ASTM C 954 except manufactured with hex washer head and neoprene or EPDM washer, No. 10 diameter by length required to penetrate steel stud flange with not less than three exposed threads.
 - a. Products: Subject to compliance with requirements, provide one of the following:
 - 1) Dayton Superior Corporation, Dur-O-Wal Division; Stainless Steel SX Fastener.
 - 2) ITW Buildex; Scots long life Teks.

2.7 MISCELLANEOUS ANCHORS

- A. Unit Type Inserts in Concrete: Cast-iron or malleable-iron wedge-type inserts.
- B. Anchor Bolts: Headed or L-shaped steel bolts complying with ASTM A 307, Grade A; with ASTM A 563 hex nuts and, where indicated, flat washers; hot-dip galvanized to comply with ASTM A 153, Class C; of dimensions indicated.
- C. Postinstalled Anchors: Chemical anchors.
 1. Material for Interior Locations: Carbon-steel components zinc plated to comply with ASTM B 633 or ASTM F 1941, Class Fe/Zn 5 unless otherwise indicated.
 2. Material for Exterior Locations and Where Stainless Steel Is Indicated: Alloy Group 2 stainless-steel bolts, ASTM F 593, and nuts, ASTM F 594.

2.8 EMBEDDED FLASHING MATERIALS

- A. Thru wall flashing system: A preassembled system that integrates a flashing membrane, drainage mat, weeps, and drip edge secured with a termination bar to the existing substrate.
 1. Manufacturer: Mortar Net
 2. Product: Total Flash System with the following options
 - a. Membrane: 5 oz Copper Laminate 18"
 - b. Termination Bar: 1-1/4 x 16 gauge thick
 - c. Drip Edge: 3 inch depth, 16 gauge thick with 3/8 inch hem.
 - d. Adhesive: As recommended by the manufacturer for the material specified
 - e. Preformed end dams and corner boots as required for a complete installation.

Weedsport Addition to Maintenance Section and Roof Replacement, MP 304.2

- B. Solder and Sealants for Sheet Metal Flashings: As specified in Division 07 Section "Sheet Metal Flashing and Trim."
- C. Adhesives, Primers, and Seam Tapes for Flashings: Flashing manufacturer's standard products or products recommended by flashing manufacturer for bonding flashing sheets to each other and to substrates.

2.9 MISCELLANEOUS MASONRY ACCESSORIES

- A. Compressible Filler: Premolded filler strips complying with ASTM D 1056, Grade 2A1; compressible up to 35 percent; of width and thickness indicated; formulated from neoprene.
- B. Preformed Control-Joint Gaskets: Made from styrene-butadiene-rubber compound, complying with ASTM D 2000, Designation M2AA-805 and designed to fit standard sash block and to maintain lateral stability in masonry wall; size and configuration as indicated.
- C. Bond-Breaker Strips: Asphalt-saturated felt complying with ASTM D 226/D 226M, Type I (No. 15 asphalt felt).
- D. Weep/Vent Products: Use the following unless otherwise indicated:
 - 1. Round Plastic Weep/Vent Tubing: Medium-density polyethylene, 3/8-inch OD by 4 inches long.
 - 2. Cellular Plastic Weep/Vent: One-piece, flexible extrusion made from UV-resistant polypropylene copolymer, full height and width of head joint and depth 1/8 inch less than depth of outer wythe, in color selected from manufacturer's standard.
- E. Cavity Drainage Material: Pea gravel or free-draining mesh, made from polymer strands that will not degrade within the wall cavity.
 - 1. Products: Subject to compliance with requirements, provide one of the following:
 - a. Advanced Building Products Inc.; Mortar Break or Mortar Break II.
 - b. Archovations, Inc.; CavClear Masonry Mat.
 - c. Dayton Superior Corporation, Dur-O-Wal Division; Polytite MortarStop.
 - d. Mortar Net USA, Ltd.; Mortar Net.
 - 2. Provide one of the following configurations:
 - a. Strips, full-depth of cavity and 10 inches high, with dovetail shaped notches 7 inches deep that prevent clogging with mortar droppings.
 - b. Strips, not less than 3/4 inch thick and 10 inches high, with dimpled surface designed to catch mortar droppings and prevent weep holes from clogging with mortar.
 - c. Sheets or strips full depth of cavity and installed to full height of cavity.
 - d. Sheets or strips not less than 3/4 inch thick and installed to full height of cavity with additional strips 4 inches high at weep holes and thick enough to fill entire depth of cavity and prevent weep holes from clogging with mortar.
- F. Reinforcing Bar Positioners: Wire units designed to fit into mortar bed joints spanning masonry unit cells and hold reinforcing bars in center of cells. Units are formed from 0.148-inch steel wire, hot-dip galvanized after fabrication. Provide units designed for number of bars indicated.
 - 1. Products: Subject to compliance with requirements, provide one of the following:
 - a. Dayton Superior Corporation, Dur-O-Wal Division; D/A 810, D/A 812 or D/A 817.
 - b. Heckmann Building Products Inc.; No. 376 Rebar Positioner.
 - c. Hohmann & Barnard, Inc.; #RB or #RB-Twin Rebar Positioner.
 - d. Wire-Bond; O-Ring or Double O-Ring Rebar Positioner.

Weedsport Addition to Maintenance Section and Roof Replacement, MP 304.2

2.10 CAVITY-WALL INSULATION

- A. Extruded-Polystyrene Board Insulation: ASTM C 578, Type IV, closed-cell product extruded with an integral skin.
- B. Adhesive: Type recommended by insulation board manufacturer for application indicated.

2.11 MASONRY CLEANERS

- A. Proprietary Acidic Cleaner: Manufacturer's standard-strength cleaner designed for removing mortar/grout stains, efflorescence, and other new construction stains from new masonry without discoloring or damaging masonry surfaces. Use product expressly approved for intended use by cleaner manufacturer and manufacturer of masonry units being cleaned.
 - 1. Manufacturers: Subject to compliance with requirements, provide products by one of the following:
 - a. Diedrich Technologies, Inc.
 - b. EaCo Chem, Inc.
 - c. ProSoCo, Inc.

2.12 MORTAR AND GROUT MIXES

- A. General: Do not use admixtures, including pigments, air-entraining agents, accelerators, retarders, water-repellent agents, antifreeze compounds, or other admixtures, unless otherwise indicated.
 - 1. Do not use calcium chloride in mortar or grout.
 - 2. Use portland cement-lime mortar unless otherwise indicated.
- B. Mortar for Unit Masonry: Comply with ASTM C 270, Proportion Specification. Provide the following types of mortar for applications stated unless another type is indicated.
 - 1. For masonry below grade or in contact with earth, use Type S.
 - 2. For reinforced masonry, use Type S.
 - 3. For mortar parge coats, use Type S.
 - 4. For exterior, above-grade, load-bearing and non-load-bearing walls and parapet walls; for interior load-bearing walls; for interior non-load-bearing partitions; and for other applications where another type is not indicated, use Type N.
 - 5. For interior non-load-bearing partitions, Type O may be used instead of Type N.
- C. Pigmented Mortar: Select and proportion pigments with other ingredients to produce color required. Do not add pigments to colored cement products.
 - 1. Pigments shall not exceed 10 percent of portland cement by weight.
 - 2. Mix to match Architect's sample.
 - 3. Application: Use pigmented mortar for exposed mortar joints with the following units:
 - a. Decorative CMUs.
 - b. Pre-faced CMUs.
 - c. Face brick.
 - d. Cast stone trim units.
- D. Colored-Aggregate Mortar: Produce required mortar color by using colored aggregates and natural color or white cement as necessary to produce required mortar color.
 - 1. Mix to match existing mortar.
 - 2. Application: Use colored aggregate mortar for exposed mortar joints with the following units:
 - a. Pre-faced CMUs.

Weedsport Addition to Maintenance Section and Roof Replacement, MP 304.2

- b. Face brick.
- E. Grout for Unit Masonry: Comply with ASTM C 476.
 - 1. Use grout of type indicated or, if not otherwise indicated, of type (fine or coarse) that will comply with Table 1.15.1 in ACI 530.1/ASCE 6/TMS 602 for dimensions of grout spaces and pour height.
 - 2. Provide grout with a slump of 8 to 11 inches as measured according to ASTM C 143.

PART 3 - EXECUTION

3.1 EXAMINATION

- A. Examine conditions, with Installer present, for compliance with requirements for installation tolerances and other conditions affecting performance of the Work.
- B. Before installation, examine rough-in and built-in construction for piping systems to verify actual locations of piping connections.
- C. Proceed with installation only after unsatisfactory conditions have been corrected.

3.2 INSTALLATION, GENERAL

- A. Thickness: Build cavity and composite walls and other masonry construction to full thickness shown. Build single-wythe walls to actual widths of masonry units, using units of widths indicated.
- B. Build chases and recesses to accommodate items specified in this and other Sections.
- C. Leave openings for equipment to be installed before completing masonry. After installing equipment, complete masonry to match the construction immediately adjacent to opening.
- D. Use full-size units without cutting if possible. If cutting is required to provide a continuous pattern or to fit adjoining construction, cut units with motor-driven saws; provide clean, sharp, unchipped edges. Allow units to dry before laying unless wetting of units is specified. Install cut units with cut surfaces and, where possible, cut edges concealed.
- E. Select and arrange units for exposed unit masonry to produce a uniform blend of colors and textures.
 - 1. Mix units from several pallets or cubes as they are placed.
- F. Matching Existing Masonry: Match coursing, bonding, color, and texture of existing masonry.
- G. Wetting of Brick: Wet brick before laying if initial rate of absorption exceeds 30 g/30 sq. in. per minute when tested per ASTM C 67. Allow units to absorb water so they are damp but not wet at time of laying.

3.3 TOLERANCES

- A. Dimensions and Locations of Elements:
 - 1. For dimensions in cross section or elevation do not vary by more than plus 1/2 inch or minus 1/4 inch.
 - 2. For location of elements in plan do not vary from that indicated by more than plus or minus 1/2 inch.
 - 3. For location of elements in elevation do not vary from that indicated by more than plus or minus 1/4 inch in a story height or 1/2 inch total.
- B. Lines and Levels:

Weedsport Addition to Maintenance Section and Roof Replacement, MP 304.2

1. For bed joints and top surfaces of bearing walls do not vary from level by more than 1/4 inch in 10 feet, or 1/2 inch maximum.
 2. For conspicuous horizontal lines, such as lintels, sills, parapets, and reveals, do not vary from level by more than 1/8 inch in 10 feet, 1/4 inch in 20 feet, or 1/2 inch maximum.
 3. For vertical lines and surfaces do not vary from plumb by more than 1/4 inch in 10 feet, 3/8 inch in 20 feet, or 1/2 inch maximum.
 4. For conspicuous vertical lines, such as external corners, door jambs, reveals, and expansion and control joints, do not vary from plumb by more than 1/8 inch in 10 feet, 1/4 inch in 20 feet, or 1/2 inch maximum.
 5. For lines and surfaces do not vary from straight by more than 1/4 inch in 10 feet, 3/8 inch in 20 feet, or 1/2 inch maximum.
 6. For vertical alignment of exposed head joints, do not vary from plumb by more than 1/4 inch in 10 feet, or 1/2 inch maximum.
 7. For faces of adjacent exposed masonry units, do not vary from flush alignment by more than 1/16 inch except due to warpage of masonry units within tolerances specified for warpage of units.
- C. Joints:
1. For bed joints, do not vary from thickness indicated by more than plus or minus 1/8 inch, with a maximum thickness limited to 1/2 inch.
 2. For exposed bed joints, do not vary from bed-joint thickness of adjacent courses by more than 1/8 inch.
 3. For head and collar joints, do not vary from thickness indicated by more than plus 3/8 inch or minus 1/4 inch.
 4. For exposed head joints, do not vary from thickness indicated by more than plus or minus 1/8 inch. Do not vary from adjacent bed-joint and head-joint thicknesses by more than 1/8 inch.
 5. For exposed bed joints and head joints of stacked bond, do not vary from a straight line by more than 1/16 inch from one masonry unit to the next.

3.4 LAYING MASONRY WALLS

- A. Lay out walls in advance for accurate spacing of surface bond patterns with uniform joint thicknesses and for accurate location of openings, movement-type joints, returns, and offsets. Avoid using less-than-half-size units, particularly at corners, jambs, and, where possible, at other locations.
- B. Bond Pattern for Exposed Masonry: Unless otherwise indicated, lay exposed masonry in running bond; do not use units with less than nominal 4-inch horizontal face dimensions at corners or jambs.
- C. Lay concealed masonry with all units in a wythe in running bond or bonded by lapping not less than 4-inches. Bond and interlock each course of each wythe at corners. Do not use units with less than nominal 4-inch horizontal face dimensions at corners or jambs.
- D. Stopping and Resuming Work: Stop work by racking back units in each course from those in course below; do not tooth. When resuming work, clean masonry surfaces that are to receive mortar, remove loose masonry units and mortar, and wet brick if required before laying fresh masonry.
- E. Built-in Work: As construction progresses, build in items specified in this and other Sections. Fill in solidly with masonry around built-in items.
- F. Fill space between steel frames and masonry solidly with mortar unless otherwise indicated.

Weedsport Addition to Maintenance Section and Roof Replacement, MP 304.2

- G. Where built-in items are to be embedded in cores of hollow masonry units, place a layer of metal lath, wire mesh, or plastic mesh in the joint below and rod mortar or grout into core.
- H. Fill cores in hollow CMUs with grout 24 inches under bearing plates, beams, lintels, posts, and similar items unless otherwise indicated.
- I. Build non-load-bearing interior partitions full height of story to underside of solid floor or roof structure above unless otherwise indicated.
 - 1. At fire-rated partitions, treat joint between top of partition and underside of structure above to comply with Division 07 Section "Fire-Resistive Joint Systems."

3.5 MORTAR BEDDING AND JOINTING

- A. Lay hollow CMUs as follows:
 - 1. With face shells fully bedded in mortar and with head joints of depth equal to bed joints.
 - 2. With webs fully bedded in mortar in all courses of piers, columns, and pilasters.
 - 3. With webs fully bedded in mortar in grouted masonry, including starting course on footings.
 - 4. With entire units, including areas under cells, fully bedded in mortar at starting course on footings where cells are not grouted.
- B. Lay solid masonry units with completely filled bed and head joints; butter ends with sufficient mortar to fill head joints and shove into place. Do not deeply furrow bed joints or slush head joints.
- C. Set trim units in full bed of mortar with full vertical joints. Fill dowel, anchor, and similar holes.
 - 1. Clean soiled surfaces with fiber brush and soap powder and rinse thoroughly with clear water.
 - 2. Allow cleaned surfaces to dry before setting.
 - 3. Wet joint surfaces thoroughly before applying mortar.
- D. Tool exposed joints slightly concave when thumbprint hard, using a jointer larger than joint thickness unless otherwise indicated.
- E. Cut joints flush for masonry walls to receive plaster or other direct-applied finishes (other than paint) unless otherwise indicated.

3.6 CAVITY WALLS

- A. Bond wythes of cavity walls together using one of the following methods:
 - 1. Masonry Veneer Anchors: Comply with requirements for anchoring masonry veneers.
- B. Keep cavities clean of mortar droppings and other materials during construction. Bevel beds away from cavity, to minimize mortar protrusions into cavity. Do not attempt to trowel or remove mortar fins protruding into cavity.
- C. Installing Cavity-Wall Insulation: Place small dabs of adhesive, spaced approximately 12 inches o.c. both ways, on inside face of insulation boards, or attach with plastic fasteners designed for this purpose. Fit courses of insulation between wall ties and other confining obstructions in cavity, with edges butted tightly both ways. Press units firmly against inside wythe of masonry or other construction as shown.
 - 1. Fill cracks and open gaps in insulation with crack sealer compatible with insulation and masonry.

Weedsport Addition to Maintenance Section and Roof Replacement, MP 304.2

3.7 MASONRY JOINT REINFORCEMENT

- A. General: Install entire length of longitudinal side rods in mortar with a minimum cover of 5/8 inch on exterior side of walls, 1/2 inch elsewhere. Lap reinforcement a minimum of 6 inches.
1. Space reinforcement not more than 16 inches o.c.
 2. Space reinforcement not more than 8 inches o.c. in foundation walls and parapet walls.
 3. Provide reinforcement not more than 8 inches above and below wall openings and extending 12 inches beyond openings.
- B. Interrupt joint reinforcement at control and expansion joints unless otherwise indicated.
- C. Cut and bend reinforcing units as directed by manufacturer for continuity at corners, returns, offsets, column fireproofing, pipe enclosures, and other special conditions.

3.8 ANCHORING MASONRY TO STRUCTURAL STEEL AND CONCRETE

- A. Anchor masonry to structural steel and concrete where masonry abuts or faces structural steel or concrete to comply with the following:
1. Provide an open space not less than 1/2 inch wide between masonry and structural steel or concrete unless otherwise indicated. Keep open space free of mortar and other rigid materials.
 2. Anchor masonry with anchors embedded in masonry joints and attached to structure.
 3. Space anchors as indicated, but not more than 24 inches o.c. vertically and 36 inches o.c. horizontally.

3.9 ANCHORING MASONRY VENEERS

- A. Anchor masonry veneers to wall framing and concrete and masonry backup with masonry-veneer anchors to comply with the following requirements:
1. Fasten screw-attached anchors through sheathing to wall framing and to concrete and masonry backup with metal fasteners of type indicated. Use two fasteners unless anchor design only uses one fastener.
 2. Embed connector sections and continuous wire in masonry joints. Provide not less than 2 inches of air space between back of masonry veneer and face of sheathing.
 3. Locate anchor sections to allow maximum vertical differential movement of ties up and down.
 4. Space anchors as indicated, but not more than 16 inches o.c. vertically and 24 inches o.c. horizontally with not less than 1 anchor for each 2.67 sq. ft. of wall area. Install additional anchors within 12 inches of openings and at intervals, not exceeding 36 inches, around perimeter.

3.10 CONTROL AND EXPANSION JOINTS

- A. General: Install control and expansion joint materials in unit masonry as masonry progresses. Do not allow materials to span control and expansion joints without provision to allow for in-plane wall or partition movement.
- B. Form expansion joints in brick as follows:
1. Form open joint full depth of brick wythe and of width indicated, but not less than 3/8 inch for installation of sealant and backer rod specified in Division 07 Section "Joint Sealants."
- C. Provide horizontal, pressure-relieving joints by either leaving an air space or inserting a compressible filler of width required for installing sealant and backer rod specified in Division 07 Section "Joint Sealants," but not less than 3/8 inch.

Weedsport Addition to Maintenance Section and Roof Replacement, MP 304.2

1. Locate horizontal, pressure-relieving joints beneath shelf angles supporting masonry.

3.11 LINTELS

- A. Install steel lintels where indicated.
- B. Provide minimum bearing of 8 inches at each jamb unless otherwise indicated.

3.12 FLASHING, WEEP HOLES, CAVITY DRAINAGE, AND VENTS

- A. General: Install embedded flashing and weep holes in masonry at shelf angles, lintels, ledges, other obstructions to downward flow of water in wall, and where indicated. Install vents at shelf angles, ledges, and other obstructions to upward flow of air in cavities, and where indicated.
- B. Install flashing as follows unless otherwise indicated:
 1. Prepare masonry surfaces so they are smooth and free from projections that could puncture flashing. Where flashing is within mortar joint, place through-wall flashing on sloping bed of mortar and cover with mortar. Before covering with mortar, seal penetrations in flashing with adhesive, sealant, or tape as recommended by flashing manufacturer.
 2. At multiwythe masonry walls, including cavity walls, extend flashing through outer wythe, turned up a minimum of 8 inches, and through inner wythe to within 1/2 inch of the interior face of wall in exposed masonry. Where interior face of wall is to receive furring or framing, carry flashing completely through inner wythe and turn flashing up approximately 2 inches on interior face.
 3. At masonry-veneer walls, extend flashing through veneer, across air space behind veneer, and up face of sheathing at least 8 inches; with upper edge tucked under building paper or building wrap, lapping at least 4 inches.
 4. At lintels and shelf angles, extend flashing a minimum of 6 inches into masonry at each end. At heads and sills, extend flashing 6 inches at ends and turn up not less than 2 inches to form end dams.
 5. Interlock end joints of ribbed sheet metal flashing by overlapping ribs not less than 1-1/2 inches or as recommended by flashing manufacturer, and seal lap with elastomeric sealant complying with requirements in Division 07 Section "Joint Sealants" for application indicated.
 6. Install metal sealant stops with ribbed sheet metal flashing by interlocking hemmed edges to form hooked seam. Seal seam with elastomeric sealant complying with requirements in Division 07 Section "Joint Sealants" for application indicated.
 7. Install metal flashing termination beneath flexible flashing at exterior face of wall. Stop flexible flashing 1/2 inch back from outside face of wall and adhere flexible flashing to top of metal flashing termination.
 8. Cut flexible flashing off flush with face of wall after masonry wall construction is completed.
- C. Install single-wythe CMU flashing system in bed joints of CMU walls where indicated to comply with manufacturer's written instructions. Install CMU cell pans with upturned edges located below face shells and webs of CMUs above and with weep spouts aligned with face of wall. Install CMU web covers so that they cover upturned edges of CMU cell pans at CMU webs and extend from face shell to face shell.
- D. Install reglets and nailers for flashing and other related construction where they are shown to be built into masonry.

Weedsport Addition to Maintenance Section and Roof Replacement, MP 304.2

- E. Install weep holes in head joints in exterior wythes of first course of masonry immediately above embedded flashing and as follows:
 1. Use specified weep/vent products or open head joints to form weep holes.
 2. Space weep holes 24 inches o.c. unless otherwise indicated.
- F. Place pea gravel in cavities as soon as practical to a height equal to height of first course above top of flashing, but not less than 2 inches, to maintain drainage.
 1. Place cavity drainage material in cavities to comply with configuration requirements for cavity drainage material in "Miscellaneous Masonry Accessories" Article.
- G. Install vents in head joints in exterior wythes at spacing indicated. Use specified weep/vent products or open head joints to form vents.
 1. Close cavities off vertically and horizontally with blocking in manner indicated. Install through-wall flashing and weep holes above horizontal blocking.

3.13 REINFORCED UNIT MASONRY INSTALLATION

- A. Placing Reinforcement: Comply with requirements in ACI 530.1/ASCE 6/TMS 602.
- B. Grouting: Do not place grout until entire height of masonry to be grouted has attained enough strength to resist grout pressure.
 1. Comply with requirements in ACI 530.1/ASCE 6/TMS 602 for cleanouts and for grout placement, including minimum grout space and maximum pour height.
 2. Limit height of vertical grout pours to not more than 60 inches.

3.14 THRU WALL FLASHING INSPECTION PROCEDURE

- A. At all area of thru wall flashing installation the completed flashing assembly shall be tested for leaks by flood testing the assembly before the brick masonry is less than 2 feet above the bottom of the flashing material. Should the results indicate that the flashing is not watertight the brickwork shall be removed and flashing resealed until no leaks are present.
 1. Continue brick masonry construction only after the Construction Manager has verified that no leaks exist in the wall construction.

3.15 FIELD QUALITY CONTROL

- A. Testing and Inspecting: Owner will engage special inspectors to perform tests and inspections and prepare reports. Allow inspectors access to scaffolding and work areas as needed to perform tests and inspections. Retesting of materials that fail to comply with specified requirements shall be done at Contractor's expense.
- B. Level B special inspections are required for masonry in nonessential facilities designed by either analytical method and for essential facilities designed by empirical method; Level C for masonry in essential facilities (IBC Occupancy Category IV) designed by either analytical method.
- C. Inspections: Special inspections according to Level B in TMS 402/ACI 530/ASCE 5.
 1. Begin masonry construction only after inspectors have verified proportions of site-prepared mortar.
 2. Place grout only after inspectors have verified compliance of grout spaces and of grades, sizes, and locations of reinforcement.
 3. Place grout only after inspectors have verified proportions of site-prepared grout.
- D. Testing Frequency: One set of tests for each 5000 sq. ft. of wall area or portion thereof.
- E. Clay Masonry Unit Test: For each type of unit provided, according to ASTM C 67 for compressive strength.

Weedsport Addition to Maintenance Section and Roof Replacement, MP 304.2

- F. Concrete Masonry Unit Test: For each type of unit provided, according to ASTM C 140 for compressive strength.
- G. Mortar Aggregate Ratio Test (Proportion Specification): For each mix provided, according to ASTM C 780.
- H. Mortar Test (Property Specification): For each mix provided, according to ASTM C 780. Test mortar for mortar air content and compressive strength.
- I. Grout Test (Compressive Strength): For each mix provided, according to ASTM C 1019.
- J. Prism Test: For each type of construction provided, according to ASTM C 1314 at 7 days and at 28 days.

3.16 PARGING

- A. Parge exterior faces of below-grade masonry walls, where indicated, in 2 uniform coats to a total thickness of 3/4 inch. Dampen wall before applying first coat and scarify first coat to ensure full bond to subsequent coat.
- B. Use a steel-trowel finish to produce a smooth, flat, dense surface with a maximum surface variation of 1/8 inch per foot. Form a wash at top of parging and a cove at bottom.
- C. Damp-cure parging for at least 24 hours and protect parging until cured.

3.17 REPAIRING, POINTING, AND CLEANING

- A. Remove and replace masonry units that are loose, chipped, broken, stained, or otherwise damaged or that do not match adjoining units. Install new units to match adjoining units; install in fresh mortar, pointed to eliminate evidence of replacement.
- B. Pointing: During the tooling of joints, enlarge voids and holes, except weep holes, and completely fill with mortar. Point up joints, including corners, openings, and adjacent construction, to provide a neat, uniform appearance. Prepare joints for sealant application, where indicated.
- C. In-Progress Cleaning: Clean unit masonry as work progresses by dry brushing to remove mortar fins and smears before tooling joints.
- D. Final Cleaning: After mortar is thoroughly set and cured, clean exposed masonry as follows:
 1. Remove large mortar particles by hand with wooden paddles and nonmetallic scrape hoes or chisels.
 2. Protect adjacent stone and nonmasonry surfaces from contact with cleaner by covering them with liquid strippable masking agent or polyethylene film and waterproof masking tape.
 3. Wet wall surfaces with water before applying cleaners; remove cleaners promptly by rinsing surfaces thoroughly with clear water.
 4. Clean brick by bucket-and-brush hand-cleaning method described in BIA Technical Notes 20.
 5. Clean masonry with a proprietary acidic cleaner applied according to manufacturer's written instructions.
 6. Clean concrete masonry by cleaning method indicated in NCMA TEK 8-2A applicable to type of stain on exposed surfaces.
 7. Clean stone trim to comply with stone supplier's written instructions.
 8. Clean limestone units to comply with recommendations in ILI's "Indiana Limestone Handbook."

Weedsport Addition to Maintenance Section and Roof Replacement, MP 304.2

3.18 FIELD QUALITY CONTROL

- A. Notify Architect's Project representatives in advance of times when lift devices and scaffolding will be relocated. Do not relocate lift devices and scaffolding until Architect's Project representatives have had reasonable opportunity to make inspections and observations of work areas at lift device or scaffold location.
- B. Inspecting: Owner will engage an inspector to perform inspections and prepare reports for thru wall flashing installation. Allow inspectors access to scaffolding and work areas, as needed to perform inspections.
- C. All thru wall flashing installed in this project shall be water tested to verify completed installations will perform as designed. These tests shall be witnessed and approved by the Architect.
 - 1. Testing will require that water be run into the brick cavity for a period of one hour to verify that no leaks exist. End dams are required at the end of all continuous through wall flashings so the water is directed to the weeps.

3.19 MASONRY WASTE DISPOSAL

- A. Salvageable Materials: Unless otherwise indicated, excess masonry materials are Contractor's property. At completion of unit masonry work, remove from Project site.
- B. Waste Disposal as Fill Material: Dispose of clean masonry waste, including excess or soil-contaminated sand, waste mortar, and broken masonry units, by crushing and mixing with fill material as fill is placed.
 - 1. Crush masonry waste to less than 4 inches in each dimension.
 - 2. Mix masonry waste with at least two parts of specified fill material for each part of masonry waste. Fill material is specified in Division 31 Section "Earth Moving."
 - 3. Do not dispose of masonry waste as fill within 18 inches of finished grade.
- C. Excess Masonry Waste: Remove excess clean masonry waste that cannot be used as fill, as described above, and other masonry waste, and legally dispose of off Owner's property.

END OF SECTION 042000

ITEM 627.0005 25**METALS****1. DESCRIPTION:**

- 1.01 Furnish all labor, materials, equipment and services necessary to complete the work as indicated on the Contract Plans and the attached Specification Summary.
- 1.02 All work shall conform to the requirements specified in Part 1 – General, of the Sections listed.

2. MATERIALS:

- 2.01 The materials shall be as specified in Part 2 – Products, of the Sections listed.

3. CONSTRUCTION DETAILS:

- 3.01 The construction details shall be as specified on Part 3 – Execution, if the Sections listed.

4. METHOD OF MEASUREMENT:

- 4.01 This item shall be measured for payment on a lump sum basis for the work completed in accordance with the Contract Documents and as directed by the Engineer.

5. BASIS OF PAYMENT:

- 5.01 Payment for this item shall be made at the lump sum bid price bid. The lump sum price bid shall include cost of furnishing all labor, material, equipment and appliances necessary to complete the work as indicated on the Contract Plans and as specified herein in the Sections listed.
- 5.02 Detailed Estimate:
 - A. Before the first certificate of payment is issued for the work under this item, submit a detailed estimate of quantities and prices for all materials, labor, and other items included under this item, which shall aggregate the contract lump sum price bid for this item. Prepare the detailed estimate in the same sequence as the Sections listed.
 - B. The detailed estimate shall be supported by such evidence, including certified copies of subcontracts, as the Engineer may require.
 - C. The detailed estimate must be approved by the Engineer who may revise it as, in his/her reasonable judgment, is necessary to make the various item conform to their true values. The value of each certificate of payment will be based on the approved detailed estimate.
- 5.03 Monthly payments will be made for this item in proportion to the total amount of work completed.

ITEM 627.0005 25**METALS****1. SPECIFICATION SUMMARY**

1.01 This Item includes the following specifications:

- A. Section 052100 STEEL JOIST FRAMING
- B. Section 053100 STEEL DECKING
- C. Section 055000 METAL FABRICATIONS

1.02 This item shall include, but not be limited to, the following:

- A. Detailing various components of metal fabrications, as well as steel joists and decking for the new roof of the building.

SECTION 052100 - STEEL JOIST FRAMING

PART 1 - GENERAL

1.1 SUMMARY

- A. This Section includes the following:
 - 1. K-series steel joists.
 - 2. Joist accessories.

1.2 DEFINITIONS

- A. SJI "Specifications": Steel Joist Institute's "Standard Specifications, Load Tables and Weight Tables for Steel Joists and Joist Girders."

1.3 PERFORMANCE REQUIREMENTS

- A. Structural Performance: Provide special joists and connections capable of withstanding design loads indicated.
- B. Design special joists to withstand design loads with live load deflections no greater than the following:
 - 1. Roof Joists: Vertical deflection of 1/240 of the span.
- C. Wind Uplift Loads:
 - 1. Eaves and Overhangs: 35 psf minimum.
 - 2. Roof Field: 20 psf minimum.

1.4 SUBMITTALS

- A. Product Data: For each type of joist, accessory, and product indicated.
- B. Shop Drawings: Show layout, designation, number, type, location, and spacing of joists. Include joining and anchorage details, bracing, bridging, joist accessories; splice and connection locations and details; and attachments to other construction.
 - 1. Indicate locations and details of bearing plates to be embedded in other construction.
 - 2. Comprehensive engineering analysis of special joists signed and sealed by the qualified professional engineer responsible for its preparation.
- C. Welding certificates.
- D. Manufacturer Certificates: Signed by manufacturers certifying that joists comply with requirements.
- E. Mill Certificates: Signed by bolt manufacturers certifying that bolts comply with requirements.
- F. Qualification Data: For manufacturer and professional engineer.
- G. Field quality-control test and inspection reports.
- H. Research/Evaluation Reports: For joists.

1.5 QUALITY ASSURANCE

- A. Manufacturer Qualifications: A manufacturer certified by SJI to manufacture joists complying with applicable standard specifications and load tables of SJI "Specifications."
 - 1. Manufacturer's responsibilities include providing professional engineering services for designing special joists to comply with performance requirements.

Weedspport Addition to Maintenance Section and Roof Replacement, MP 304.2

- B. SJI Specifications: Comply with standard specifications in SJI's "Specifications" that are applicable to types of joists indicated.
- C. Welding: Qualify field-welding procedures and personnel according to AWS D1.1, "Structural Welding Code - Steel."

1.6 DELIVERY, STORAGE, AND HANDLING

- A. Deliver, store, and handle joists as recommended in SJI's "Specifications."
- B. Protect joists from corrosion, deformation, and other damage during delivery, storage, and handling.

1.7 SEQUENCING

- A. Deliver steel bearing plates to be built into cast-in-place concrete and masonry construction.

PART 2 - PRODUCTS**2.1 PERFORMANCE REQUIREMENTS**

- A. Structural Performance: Provide special joists and connections capable of withstanding design loads indicated.
 - 1. Use ASD; data are given at service-load level.
 - 2. Design special joists to withstand design loads with live-load deflections no greater than the following:
 - a. Roof Joists: Vertical deflection of 1/360 of the span.

2.2 MATERIALS

- A. Steel: Comply with SJI's "Specifications" for web and steel-angle chord members.
- B. Steel Bearing Plates: ASTM A 36.
- C. Carbon-Steel Bolts and Threaded Fasteners: ASTM A 307, Grade A, carbon-steel, hex-head bolts and threaded fasteners; carbon-steel nuts; and flat, unhardened steel washers.
 - 1. Finish: Plain, uncoated.

2.3 K-SERIES STEEL JOISTS

- A. Manufacture steel joists of type indicated according to "Standard Specifications for Open Web Steel Joists, K-Series" in SJI's "Specifications," with steel-angle top- and bottom-chord members, underslung ends, and parallel top chord.
 - 1. Joist Type: K-series steel joists].
- B. Comply with AWS requirements and procedures for shop welding, appearance, quality of welds, and methods used in correcting welding work.
- C. Top-Chord Extensions: Extend top chords of joists with SJI's Type S top-chord extensions where indicated, complying with SJI's "Specifications."
- D. Do not camber joists.
- E. Equip bearing ends of joists with manufacturer's standard beveled ends or sloped shoes if joist slope exceeds 1/4 inch per 12 inches.
- F. Primer: SSPC-Paint 15, or manufacturer's standard shop primer complying with performance requirements in SSPC-Paint 15.

WeedSPORT Addition to Maintenance Section and Roof Replacement, MP 304.2

- G. Primer: Provide shop primer that complies with Division 09 Sections "Exterior Painting", "Interior Painting", and "High-Performance Coatings".

2.4 JOIST ACCESSORIES

- A. Bridging: Provide bridging anchors and number of rows of horizontal or diagonal bridging of material, size, and type required by SJI's "Specifications" for type of joist, chord size, spacing, and span. Furnish additional erection bridging if required for stability.
- B. Fabricate steel bearing plates from ASTM A 36 steel with integral anchorages of sizes and thicknesses indicated. Shop prime paint.
- C. Supply ceiling extensions, either extended bottom-chord elements or a separate extension unit of enough strength to support ceiling construction. Extend ends to within 1/2 inch of finished wall surface, unless otherwise indicated.
- D. Supply miscellaneous accessories, including splice plates and bolts required by joist manufacturer to complete joist installation.
- E. High-Strength Bolts, Nuts, and Washers: ASTM A 325, Type 1, heavy hex steel structural bolts; ASTM A 563 heavy hex carbon-steel nuts; and ASTM F 436 hardened carbon-steel washers.
1. Finish: Plain.
- F. Welding Electrodes: Comply with AWS standards.

2.5 CLEANING AND SHOP PAINTING

- A. Clean and remove loose scale, heavy rust, and other foreign materials from fabricated joists and accessories by hand-tool cleaning, SSPC-SP 2 or power-tool cleaning, SSPC-SP 3.
- B. Do not prime paint joists and accessories to receive sprayed fire-resistive materials.
- C. Apply 1 coat of shop primer to joists and joist accessories to be primed to provide a continuous, dry paint film not less than 1 mil thick.

PART 3 - EXECUTION**3.1 EXAMINATION**

- A. Examine supporting substrates, embedded bearing plates, and abutting structural framing for compliance with requirements for installation tolerances and other conditions affecting performance.
1. Proceed with installation only after unsatisfactory conditions have been corrected.

3.2 INSTALLATION

- A. Do not install joists until supporting construction is in place and secured.
- B. Install joists and accessories plumb, square, and true to line; securely fasten to supporting construction according to SJI's "Specifications," joist manufacturer's written recommendations, and requirements in this Section.
1. Before installation, splice joists delivered to Project site in more than one piece.
2. Space, adjust, and align joists accurately in location before permanently fastening.
3. Install temporary bracing and erection bridging, connections, and anchors to ensure that joists are stabilized during construction.
4. Delay rigidly connecting bottom-chord extensions to columns or supports until dead loads have been applied.

Weedsport Addition to Maintenance Section and Roof Replacement, MP 304.2

- C. Field weld joists to supporting steel bearing plates. Coordinate welding sequence and procedure with placement of joists. Comply with AWS requirements and procedures for welding, appearance and quality of welds, and methods used in correcting welding work.
 - 1. Weld and bolt joists with end movement connections as indicated.
- D. Bolt joists to supporting steel framework using carbon-steel bolts, 2-3/4-inch minimum.
- E. Bolt joists to supporting steel framework using high-strength structural bolts. Comply with RCSC's "Specification for Structural Joints Using ASTM A 325 or ASTM A 490 Bolts" for high-strength structural bolt installation and tightening requirements.
- F. Install and connect bridging concurrently with joist erection, before construction loads are applied. Anchor ends of bridging lines at top and bottom chords if terminating at walls or beams.

3.3 FIELD QUALITY CONTROL

- A. Testing Agency: Owner will engage a qualified independent testing and inspecting agency to inspect field welds and bolted connections and to perform field tests and inspections and prepare test and inspection reports.
- B. Field welds will be visually inspected according to AWS D1.1.
- C. Bolted connections will be visually inspected.
- D. High-strength, field-bolted connections will be tested and verified according to procedures in RCSC's "Specification for Structural Joints Using ASTM A 325 or ASTM A 490 Bolts."
- E. Correct deficiencies in Work that test and inspection reports have indicated are not in compliance with specified requirements.
- F. Additional testing will be performed to determine compliance of corrected Work with specified requirements.

3.4 REPAIRS AND PROTECTION

- A. Touchup Painting: After installation, promptly clean, prepare, and prime or reprime field connections, rust spots, and abraded surfaces of prime-painted joists, bearing plates, abutting structural steel, and accessories.
 - 1. Clean and prepare surfaces by hand-tool cleaning, SSPC-SP 2, or power-tool cleaning, SSPC-SP 3.
 - 2. Apply a compatible primer of same type as shop primer used on adjacent surfaces.
- B. Provide final protection and maintain conditions, in a manner acceptable to manufacturer and Installer, that ensure that joists and accessories are without damage or deterioration at time of Substantial Completion.

END OF SECTION 052100

SECTION 053100 - STEEL DECKING

PART 1 - GENERAL

1.1 SUMMARY

- A. This Section includes the following:
 - 1. Roof deck.

1.2 SUBMITTALS

- A. Product Data: For each type of deck, accessory, and product indicated.
- B. Shop Drawings: Show layout and types of deck panels, anchorage details, reinforcing channels, pans, cut deck openings, special jointing, accessories, and attachments to other construction.
- C. Product Certificates: For each type of steel deck, signed by product manufacturer.
- D. Welding certificates.
- E. Field quality-control test and inspection reports.
- F. Product Test Reports: Based on evaluation of comprehensive tests performed by a qualified testing agency, indicating that each of the following complies with requirements:
 - 1. Power-actuated mechanical fasteners.
- G. Evaluation Reports: For steel deck, from ICC-ES.

1.3 QUALITY ASSURANCE

- A. Testing Agency Qualifications: An independent agency qualified according to ASTM E 329 for testing indicated.
- B. Welding: Qualify procedures and personnel according to AWS D1.3, "Structural Welding Code - Sheet Steel."
- C. FMG Listing: Provide steel roof deck evaluated by FMG and listed in its "Approval Guide, Building Materials" for Class 1 fire rating and Class 1-90 windstorm ratings.

1.4 DELIVERY, STORAGE, AND HANDLING

- A. Protect steel deck from corrosion, deformation, and other damage during delivery, storage, and handling.
- B. Stack steel deck on platforms or pallets and slope to provide drainage. Protect with a waterproof covering and ventilate to avoid condensation.
 - 1. Protect and ventilate acoustical cellular roof deck with factory-installed insulation to maintain insulation free of moisture.

PART 2 - PRODUCTS

2.1 PERFORMANCE REQUIREMENTS

- A. AISI Specifications: Comply with calculated structural characteristics of steel deck according to AISI's "North American Specification for the Design of Cold-Formed Steel Structural Members."

Weedsport Addition to Maintenance Section and Roof Replacement, MP 304.2

- B. Fire-Resistance Ratings: Where indicated, provide steel deck units identical to those tested for fire resistance per ASTM E 119 by a testing and inspecting agency acceptable to authorities having jurisdiction.
1. Indicate by design designations of applicable testing and inspecting agency.
 2. Indicate design designations from UL's "fire Resistance Directory" or from the listings of another qualified testing agency

2.2 MANUFACTURERS

- A. Fire-Test-Response Characteristics: Where indicated, provide steel deck units identical to those tested for fire resistance per ASTM E 119 by a testing and inspecting agency acceptable to authorities having jurisdiction.
1. Fire-Resistance Ratings: Indicated by design designations of applicable testing and inspecting agency.
 2. Steel deck units shall be identified with appropriate markings of applicable testing and inspecting agency.
- B. Manufacturers: Subject to compliance with requirements, provide products by one of the following:
1. Steel Deck:
 - a. Epic Metals Corporation.
 - b. Nucor Corp.; Vulcraft Division.
 - c. Roof Deck, Inc.
 - d. United Steel Deck, Inc.
 - e. Verco Manufacturing Co.

2.3 ROOF DECK

- A. Steel Roof Deck: Fabricate panels, without top-flange stiffening grooves, to comply with "SDI Specifications and Commentary for Steel Roof Deck," in SDI Publication No. 31, and with the following:
1. Galvanized Steel Sheet: ASTM A 653, Structural Steel, Grade 33, G60 zinc coating.
 2. Galvanized and Shop-Primed Steel Sheet: ASTM A 653, Structural Steel, Grade 33, G60 zinc coating; cleaned, pretreated, and primed with manufacturer's standard baked-on, rust-inhibitive primer.
 - a. Color: White.
 3. Deck Profile: Type WR, wide rib.
 4. Profile Depth: 1-1/2 inches, unless otherwise indicated.
 5. Design Uncoated-Steel Thickness: 0.0358 inch.
 6. Span Condition: As indicated.
 7. Side Laps: Overlapped.

2.4 ACCESSORIES

- A. General: Provide manufacturer's standard accessory materials for deck that comply with requirements indicated.
- B. Mechanical Fasteners: Corrosion-resistant, low-velocity, power-actuated or pneumatically driven carbon-steel fasteners; or self-drilling, self-threading screws.
- C. Side-Lap Fasteners: Corrosion-resistant, hexagonal washer head; self-drilling, carbon-steel screws, No. 10 minimum diameter.
- D. Flexible Closure Strips: Vulcanized, closed-cell, synthetic rubber.

Weedspport Addition to Maintenance Section and Roof Replacement, MP 304.2

- E. Miscellaneous Sheet Metal Deck Accessories: Steel sheet, minimum yield strength of 33,000 psi, not less than 0.0359-inch design uncoated thickness, of same material and finish as deck; of profile indicated or required for application.
- F. Piercing Hanger Tabs: Piercing steel sheet hanger attachment devices for use with floor deck.
- G. Weld Washers: Uncoated steel sheet, shaped to fit deck rib, 0.0598 inch thick, with factory-punched hole of 3/8-inch minimum diameter.
- H. Recessed Sump Pans: Single-piece steel sheet, 0.0747 inch thick, of same material and finish as deck, with 3-inch- wide flanges and level recessed pans of 1-1/2-inch minimum depth. For drains, cut holes in the field.
- I. Flat Sump Plate: Single-piece steel sheet, 0.0747 inch thick, of same material and finish as deck. For drains, cut holes in the field.
- J. Galvanizing Repair Paint: SSPC-Paint 20 or MIL-P-21035B, with dry film containing a minimum of 94 percent zinc dust by weight.
- K. Repair Paint: Manufacturer's standard rust-inhibitive primer of same color as primer.

PART 3 - EXECUTION

3.1 EXAMINATION

- A. Examine supporting frame and field conditions for compliance with requirements for installation tolerances and other conditions affecting performance.
- B. Proceed with installation only after unsatisfactory conditions have been corrected.

3.2 INSTALLATION, GENERAL

- A. Install deck panels and accessories according to applicable specifications and commentary in SDI Publication No. 31, manufacturer's written instructions, and requirements in this Section.
- B. Install temporary shoring before placing deck panels, if required to meet deflection limitations.
- C. Locate deck bundles to prevent overloading of supporting members.
- D. Place deck panels flat and square and fasten to supporting frame without warp or deflection.
- E. Cut and neatly fit deck panels and accessories around openings and other work projecting through or adjacent to deck.
- F. Provide additional reinforcement and closure pieces at openings as required for strength, continuity of deck, and support of other work.
- G. Comply with AWS requirements and procedures for manual shielded metal arc welding, appearance and quality of welds, and methods used for correcting welding work.
- H. Mechanical fasteners may be used in lieu of welding to fasten deck. Locate mechanical fasteners and install according to deck manufacturer's written instructions.

3.3 ROOF-DECK INSTALLATION

- A. Fasten roof-deck panels to steel supporting members by arc spot (puddle) welds of the surface diameter indicated or arc seam welds with an equal perimeter that is not less than 1-1/2 inches long, and as follows:
 1. Weld Diameter: 5/8 inch, nominal.

Weedspport Addition to Maintenance Section and Roof Replacement, MP 304.2

2. Weld Spacing: Weld edge and interior ribs of deck units with a minimum of two welds per deck unit at each support. Space welds 12 inches apart in the field of roof and 6 inches apart in roof corners and perimeter, based on roof-area definitions in FMG Loss Prevention Data Sheet 1-28.
 3. Weld Washers: Install weld washers at each weld location.
- B. Side-Lap and Perimeter Edge Fastening: Fasten side laps and perimeter edges of panels between supports, at intervals not exceeding the lesser of 1/2 of the span or 36 inches, and as follows:
1. Mechanically fasten with self-drilling, No. 10 diameter or larger, carbon-steel screws.
 2. Fasten with a minimum of 1-1/2-inch- long welds.
- C. End Bearing: Install deck ends over supporting frame with a minimum end bearing of 1-1/2 inches, with end joints as follows:
1. End Joints: Lapped 2 inches minimum.
- D. Roof Sump Pans and Sump Plates: Install over openings provided in roof deck and mechanically fasten flanges to top of deck. Space mechanical fasteners not more than 12 inches apart with at least one fastener at each corner.
- E. Miscellaneous Roof-Deck Accessories: Install ridge and valley plates, finish strips, end closures, and reinforcing channels according to deck manufacturer's written instructions. Weld or mechanically fasten to substrate to provide a complete deck installation.
1. Weld cover plates at changes in direction of roof-deck panels, unless otherwise indicated.
- F. Flexible Closure Strips: Install flexible closure strips over partitions, walls, and where indicated. Install with adhesive according to manufacturer's written instructions to ensure complete closure.
- G. Sound-Absorbing Insulation: Installation into topside ribs of deck as specified in in Division 07 Section "Roofing".

3.4 FIELD QUALITY CONTROL

- A. Testing Agency: Owner will engage a qualified independent testing and inspecting agency to perform field tests and inspections and prepare test reports.
- B. Field welds will be subject to inspection.
- C. Testing agency will report inspection results promptly and in writing to Contractor and Architect.
- D. Remove and replace work that does not comply with specified requirements.
- E. Additional inspecting, at Contractor's expense, will be performed to determine compliance of corrected work with specified requirements.

3.5 REPAIRS AND PROTECTION

- A. Galvanizing Repairs: Prepare and repair damaged galvanized coatings on both surfaces of deck with galvanized repair paint according to ASTM A 780 and manufacturer's written instructions.
- B. Repair Painting: Wire brush and clean rust spots, welds, and abraded areas on both surfaces of prime-painted deck immediately after installation, and apply repair paint.
 1. Apply repair paint, of same color as adjacent shop-primed deck, to bottom surfaces of deck exposed to view.
 2. Wire brushing, cleaning, and repair painting of bottom deck surfaces are included in Division 09 Sections "Exterior Painting" and "Interior Painting."

Weedspport Addition to Maintenance Section and Roof Replacement, MP 304.2

- C. Provide final protection and maintain conditions to ensure that steel deck is without damage or deterioration at time of Substantial Completion.

END OF SECTION 05 3100

SECTION 055000 - METAL FABRICATIONS

PART 1 - GENERAL

1.1 SUMMARY

- A. Section Includes:
1. Steel framing and supports for applications where framing and supports are not specified in other Sections.
 2. Shelf angles.
 3. Loose bearing and leveling plates for applications where they are not specified in other Sections.
- B. Products furnished, but not installed, under this Section:
1. Loose steel lintels. Loose steel headers
 2. Anchor bolts, steel pipe sleeves.

1.2 SUBMITTALS

- A. Product Data: For the following:
1. Paint products.
 2. Grout.
- B. Shop Drawings: Show fabrication and installation details for metal fabrications.
1. Include plans, elevations, sections, and details of metal fabrications and their connections. Show anchorage and accessory items.

1.3 QUALITY ASSURANCE

- A. Welding Qualifications: Qualify procedures and personnel according to AWS D1.1 "Structural Welding Code - Steel."

1.4 PROJECT CONDITIONS

- A. Field Measurements: Verify actual locations of walls and other construction contiguous with metal fabrications by field measurements before fabrication.

1.5 COORDINATION

- A. Coordinate selection of shop primers with topcoats to be applied over them. Comply with paint and coating manufacturers' written recommendations to ensure that shop primers and topcoats are compatible with one another.
- B. Coordinate installation of anchorages and steel weld plates and angles for casting into concrete. Furnish setting drawings, templates, and directions for installing anchorages, including sleeves, concrete inserts, anchor bolts, and items with integral anchors, that are to be embedded in concrete or masonry. Deliver such items to Project site in time for installation.

PART 2 - PRODUCTS

2.1 METALS, GENERAL

- A. Metal Surfaces, General: Provide materials with smooth, flat surfaces unless otherwise indicated. For metal fabrications exposed to view in the completed Work, provide materials without seam marks, roller marks, rolled trade names, or blemishes.

Weedsport Addition to Maintenance Section and Roof Replacement, MP 304.2

2.2 FERROUS METALS

- A. Recycled Content of Steel Products: Provide products with average recycled content of steel products so postconsumer recycled content plus one-half of preconsumer recycled content is not less than 25 percent.
- B. Steel Plates, Shapes, and Bars: ASTM A 36.
- C. Steel Tubing: ASTM A 500, cold-formed steel tubing.
- D. Steel Pipe: ASTM A 53, standard weight (Schedule 40) unless otherwise indicated.
- E. Slotted Channel Framing: Cold-formed metal box channels (struts) complying with MFMA-4.
 - 1. Size of Channels: 1-5/8 by 1-5/8 inches unless otherwise indicated.
 - 2. Material: Cold-rolled steel, ASTM A 1008, structural steel, Grade 33; 0.0528-inch minimum thickness; unfinished.
- F. Cast Iron: Either gray iron, ASTM A 48, or malleable iron, ASTM A 47, unless otherwise indicated.

2.3 FASTENERS

- A. General: Unless otherwise indicated, provide Type 316 stainless-steel fasteners for exterior use and zinc-plated fasteners with coating complying with ASTM B 633 or ASTM F 1941, Class Fe/Zn 5, at exterior walls. Select fasteners for type, grade, and class required.
 - 1. Provide stainless-steel fasteners for fastening aluminum.
- B. Steel Bolts and Nuts: Regular hexagon-head bolts, ASTM A 307, Grade A; with hex nuts, ASTM A 563; and, where indicated, flat washers.
- C. Stainless-Steel Bolts and Nuts: Regular hexagon-head annealed stainless-steel bolts, ASTM F 593; with hex nuts, ASTM F 594; and, where indicated, flat washers; Alloy Group 2.
- D. Anchor Bolts: ASTM F 1554, Grade 36, of dimensions indicated; with nuts, ASTM A 563; and, where indicated, flat washers.
 - 1. Hot-dip galvanize or provide mechanically deposited, zinc coating where item being fastened is indicated to be galvanized.
- E. Cast-in-Place Anchors in Concrete: Either threaded type or wedge type unless otherwise indicated; galvanized ferrous castings, either ASTM A 47 malleable iron or ASTM A 27 cast steel. Provide bolts, washers, and shims as needed, all hot-dip galvanized per ASTM F 2329.
- F. Post-Installed Anchors: Chemical anchors.
 - 1. Material for Interior Locations: Carbon-steel components zinc plated to comply with ASTM B 633 or ASTM F 1941, Class Fe/Zn 5, unless otherwise indicated.
 - 2. Material for Exterior Locations and Where Stainless Steel is Indicated: Alloy Group 2 stainless-steel bolts, ASTM F 593, and nuts, ASTM F 594.
- G. Slotted-Channel Inserts: Cold-formed, hot-dip galvanized-steel box channels (struts) complying with MFMA-4, 1-5/8 by 7/8 inches by length indicated with anchor straps or studs not less than 3 inches long at not more than 8 inches o.c. Provide with temporary filler and tee-head bolts, complete with washers and nuts, all zinc-plated to comply with ASTM B 633, Class Fe/Zn 5, as needed for fastening to inserts.

2.4 MISCELLANEOUS MATERIALS

- A. Welding Rods and Bare Electrodes: Select according to AWS specifications for metal alloy welded.

Weedsport Addition to Maintenance Section and Roof Replacement, MP 304.2

- B. Universal Shop Primer: Fast-curing, lead- and chromate-free, universal modified-alkyd primer complying with MPI#79 and compatible with topcoat.
- C. Galvanizing Repair Paint: High-zinc-dust-content paint complying with SSPC-Paint 20 and compatible with paints specified to be used over it.
- D. Bituminous Paint: Cold-applied asphalt emulsion complying with ASTM D 1187.
- E. Non-shrink, Nonmetallic Grout: Factory-packaged, non-staining, noncorrosive, nongaseous grout complying with ASTM C 1107. Provide grout specifically recommended by manufacturer for interior and exterior applications.

2.5 FABRICATION, GENERAL

- A. Shop Assembly: Preassemble items in the shop to greatest extent possible. Disassemble units only as necessary for shipping and handling limitations. Use connections that maintain structural value of joined pieces. Clearly mark units for reassembly and coordinated installation.
- B. Cut, drill, and punch metals cleanly and accurately. Remove burrs and ease edges to a radius of approximately 1/32 inch unless otherwise indicated. Remove sharp or rough areas on exposed surfaces.
- C. Weld corners and seams continuously to comply with the following:
 1. Use materials and methods that minimize distortion and develop strength and corrosion resistance of base metals.
 2. Obtain fusion without undercut or overlap.
 3. Remove welding flux immediately.
 4. At exposed connections, finish exposed welds and surfaces smooth and blended so no roughness shows after finishing and contour of welded surface matches that of adjacent surface.
- D. Form exposed connections with hairline joints, flush and smooth, using concealed fasteners or welds where possible. Where exposed fasteners are required, use Phillips flat-head (countersunk) fasteners unless otherwise indicated. Locate joints where least conspicuous.
- E. Fabricate seams and other connections that will be exposed to weather in a manner to exclude water. Provide weep holes where water may accumulate.
- F. Cut, reinforce, drill, and tap metal fabrications as indicated to receive finish hardware, screws, and similar items.
- G. Provide for anchorage of type indicated; coordinate with supporting structure. Space anchoring devices to secure metal fabrications rigidly in place and to support indicated loads.
 1. Where units are indicated to be cast into concrete or built into masonry, equip with integrally welded steel strap anchors, 1/8 by 1-1/2 inches, with a minimum 6-inch embedment and 2-inch hook, not less than 8 inches from ends and corners of units and 24 inches o.c., unless otherwise indicated.

2.6 LOOSE BEARING AND LEVELING PLATES

- A. Provide loose bearing and leveling plates for steel items bearing on masonry or concrete construction. Drill plates to receive anchor bolts and for grouting.
- B. Galvanize plates.

2.7 LOOSE STEEL LINTELS

- A. Fabricate loose steel lintels from steel angles and shapes of size indicated for openings and recesses in masonry walls and partitions at locations indicated. Fabricate in single lengths for

Weedsport Addition to Maintenance Section and Roof Replacement, MP 304.2

each opening unless otherwise indicated. Weld adjoining members together to form a single unit where indicated.

- B. Size loose lintels to provide bearing length at each side of openings equal to 1/12 of clear span but not less than 8 inches unless otherwise indicated.
- C. Galvanize loose steel lintels located in exterior walls.

2.8 STEEL WELD PLATES AND ANGLES

- A. Provide steel weld plates and angles not specified in other Sections, for items supported from concrete construction as needed to complete the Work. Provide each unit with no fewer than two integrally welded steel strap anchors for embedding in concrete.

2.9 FINISHES, GENERAL

- A. Comply with NAAMM's "Metal Finishes Manual for Architectural and Metal Products" for recommendations for applying and designating finishes.
- B. Finish metal fabrications after assembly.
- C. Finish exposed surfaces to remove tool and die marks and stretch lines, and to blend into surrounding surface.

2.10 STEEL AND IRON FINISHES

- A. Galvanizing: Hot-dip galvanize items as indicated to comply with ASTM A 153/A 153M for steel and iron hardware and with ASTM A 123/A 123M for other steel and iron products.
 - 1. Do not quench or apply post galvanizing treatments that might interfere with paint adhesion.
- B. Shop prime iron and steel items not indicated to be galvanized unless they are to be embedded in concrete, or masonry, or unless otherwise indicated.
 - 1. Shop prime with universal shop primer unless indicated.
- C. Preparation for Shop Priming: Prepare surfaces to comply with requirements indicated below:
 - 1. Exterior Items: SSPC-SP 6/NACE No. 3, "Commercial Blast Cleaning."
 - 2. Other Items: SSPC-SP 3, "Power Tool Cleaning."
- D. Shop Priming: Apply shop primer to comply with SSPC-PA 1, "Paint Application Specification No. 1: Shop, Field, and Maintenance Painting of Steel," for shop painting.
 - 1. Stripe paint corners, crevices, bolts, welds, and sharp edges.

PART 3 - EXECUTION**3.1 INSTALLATION, GENERAL**

- A. Cutting, Fitting, and Placement: Perform cutting, drilling, and fitting required for installing metal fabrications. Set metal fabrications accurately in location, alignment, and elevation; with edges and surfaces level, plumb, true, and free of rack; and measured from established lines and levels.
- B. Fit exposed connections accurately together to form hairline joints. Weld connections that are not to be left as exposed joints but cannot be shop welded because of shipping size limitations. Do not weld, cut, or abrade surfaces of exterior units that have been hot-dip galvanized after fabrication and are for bolted or screwed field connections.
- C. Field Welding: Comply with the following requirements:
 - 1. Use materials and methods that minimize distortion and develop strength and corrosion resistance of base metals.

Weedsport Addition to Maintenance Section and Roof Replacement, MP 304.2

2. Obtain fusion without undercut or overlap.
 3. Remove welding flux immediately.
 4. At exposed connections, finish exposed welds and surfaces smooth and blended so no roughness shows after finishing and contour of welded surface matches that of adjacent surface.
- D. Fastening to In-Place Construction: Provide anchorage devices and fasteners where metal fabrications are required to be fastened to in-place construction. Provide threaded fasteners for use with concrete and masonry inserts, toggle bolts, through bolts, lag screws, wood screws, and other connectors.
- E. Provide temporary bracing or anchors in formwork for items that are to be built into concrete, masonry, or similar construction.

3.2 INSTALLING MISCELLANEOUS FRAMING AND SUPPORTS

- A. General: Install framing and supports to comply with requirements of items being supported, including manufacturers' written instructions and requirements indicated on Shop Drawings.
- B. Anchor supports for operable partitions securely to and rigidly brace from building structure.

3.3 INSTALLING BEARING AND LEVELING PLATES

- A. Clean concrete and masonry bearing surfaces of bond-reducing materials, and roughen to improve bond to surfaces. Clean bottom surface of plates.
- B. Set bearing and leveling plates on wedges, shims, or leveling nuts. After bearing members have been positioned and plumbed, tighten anchor bolts. Do not remove wedges or shims but, if protruding, cut off flush with edge of bearing plate before packing with grout.
1. Use nonshrink, nonmetallic grout in all locations unless otherwise indicated.
 2. Pack grout solidly between bearing surfaces and plates to ensure that no voids remain.

3.4 ADJUSTING AND CLEANING

- A. Touchup Painting: Immediately after erection, clean field welds, bolted connections, and abraded areas. Paint uncoated and abraded areas with the same material as used for shop painting to comply with SSPC-PA 1 for touching up shop-painted surfaces.
1. Apply by brush or spray to provide a minimum 2.0-mil dry film thickness.
- B. Galvanized Surfaces: Clean field welds, bolted connections, and abraded areas and repair galvanizing to comply with ASTM A 780.

END OF SECTION 055000

ITEM 627.0006 25**WOOD, PLASTICS AND COMPOSITES****1. DESCRIPTION:**

- 1.01 Furnish all labor, materials, equipment and services necessary to complete the work as indicated on the Contract Plans and the attached Specification Summary.
- 1.02 All work shall conform to the requirements specified in Part 1 – General, of the Sections listed.

2. MATERIALS:

- 2.01 The materials shall be as specified in Part 2 – Products, of the Sections listed.

3. CONSTRUCTION DETAILS:

- 3.01 The construction details shall be as specified on Part 3 – Execution, if the Sections listed.

4. METHOD OF MEASUREMENT:

- 4.01 This item shall be measured for payment on a lump sum basis for the work completed in accordance with the Contract Documents and as directed by the Engineer.

5. BASIS OF PAYMENT:

- 5.01 Payment for this item shall be made at the lump sum bid price bid. The lump sum price bid shall include cost of furnishing all labor, material, equipment and appliances necessary to complete the work as indicated on the Contract Plans and as specified herein in the Sections listed.
- 5.02 Detailed Estimate:
 - A. Before the first certificate of payment is issued for the work under this item, submit a detailed estimate of quantities and prices for all materials, labor, and other items included under this item, which shall aggregate the contract lump sum price bid for this item. Prepare the detailed estimate in the same sequence as the Sections listed.
 - B. The detailed estimate shall be supported by such evidence, including certified copies of subcontracts, as the Engineer may require.
 - C. The detailed estimate must be approved by the Engineer who may revise it as, in his/her reasonable judgment, is necessary to make the various item conform to their true values. The value of each certificate of payment will be based on the approved detailed estimate.
- 5.03 Monthly payments will be made for this item in proportion to the total amount of work completed.

ITEM 627.0006 25**WOOD, PLASTICS AND COMPOSITES****1. SPECIFICATION SUMMARY**

1.01 This Item includes the following specifications:

- A. Section 061053 MISCELLANOUS ROUGH CARPENTRY
- B. Section 064023 INTERIOR ARCHITECTURAL

1.02 This item shall include, but not be limited to, the following:

- A. Placement of various interior components for the new break room in the building's addition
- B. Miscellaneous interior architectural components

SECTION 061053 - MISCELLANEOUS ROUGH CARPENTRY

PART 1 - GENERAL

1.1 SUMMARY

- A. Section Includes:
1. Framing with dimension lumber.
 2. Wood blocking, cants, and nailers.
 3. Plywood backing panels.

1.2 DEFINITIONS

- A. Dimension Lumber: Lumber of 2 inches nominal or greater but less than 5 inches nominal in least dimension.
- B. Lumber grading agencies, and the abbreviations used to reference them, include the following:
1. NeLMA: Northeastern Lumber Manufacturers' Association.
 2. NHLA: National Hardwood Lumber Association.
 3. NLGA: National Lumber Grades Authority.
 4. SPIB: The Southern Pine Inspection Bureau.
 5. WCLIB: West Coast Lumber Inspection Bureau.
 6. WWPA: Western Wood Products Association.

1.3 ACTION SUBMITTALS

- A. Product Data: For each type of process and factory-fabricated product. Indicate component materials and dimensions and include construction and application details.
1. Include data for wood-preservative treatment from chemical treatment manufacturer and certification by treating plant that treated materials comply with requirements. Indicate type of preservative used and net amount of preservative retained.
 2. Include data for fire-retardant treatment from chemical treatment manufacturer and certification by treating plant that treated materials comply with requirements. Include physical properties of treated materials based on testing by a qualified independent testing agency.
 3. For fire-retardant treatments, include physical properties of treated lumber both before and after exposure to elevated temperatures, based on testing by a qualified independent testing agency according to ASTM D 5664.
 4. For products receiving a waterborne treatment, include statement that moisture content of treated materials was reduced to levels specified before shipment to Project site.
 5. Include copies of warranties from chemical treatment manufacturers for each type of treatment.

1.4 INFORMATIONAL SUBMITTALS

- A. Evaluation Reports: For the following, from ICC-ES:
1. Preservative-treated wood.
 2. Fire-retardant-treated wood.
 3. Power-driven fasteners.
 4. Powder-actuated fasteners.
 5. Expansion anchors.

Weedsport Addition to Maintenance Section and Roof Replacement, MP 304.2

1.5 QUALITY ASSURANCE

- A. Testing Agency Qualifications: For testing agency providing classification marking for fire-retardant treated material, an inspection agency acceptable to authorities having jurisdiction that periodically performs inspections to verify that the material bearing the classification marking is representative of the material tested.

1.6 DELIVERY, STORAGE, AND HANDLING

- A. Stack lumber flat with spacers beneath and between each bundle to provide air circulation. Protect lumber from weather by covering with waterproof sheeting, securely anchored. Provide for air circulation around stacks and under coverings.

PART 2 - PRODUCTS**2.1 WOOD PRODUCTS, GENERAL**

- A. Lumber: DOC PS 20 and applicable rules of grading agencies indicated. If no grading agency is indicated, provide lumber that complies with the applicable rules of any rules-writing agency certified by the ALSC Board of Review. Provide lumber graded by an agency certified by the ALSC Board of Review to inspect and grade lumber under the rules indicated.
1. Factory mark each piece of lumber with grade stamp of grading agency.
 2. Where nominal sizes are indicated, provide actual sizes required by DOC PS 20 for moisture content specified. Where actual sizes are indicated, they are minimum dressed sizes for dry lumber.
 3. Provide dressed lumber, S4S, unless otherwise indicated.
- B. Maximum Moisture Content of Lumber: 15 percent for 2-inch nominal thickness or less, 19 percent for more than 2-inch nominal thickness unless otherwise indicated.

2.2 WOOD-PRESERVATIVE-TREATED MATERIALS

- A. Preservative Treatment by Pressure Process: AWWA U1; Use Category UC2.
1. Preservative Chemicals: Acceptable to authorities having jurisdiction and containing no arsenic or chromium.
 2. For exposed items indicated to receive a stained or natural finish, use chemical formulations that do not require incising, contain colorants, bleed through, or otherwise adversely affect finishes.
- B. Kiln-dry lumber after treatment to a maximum moisture content of 15 percent. Do not use material that is warped or does not comply with requirements for untreated material.
- C. Mark lumber with treatment quality mark of an inspection agency approved by the ALSC Board of Review.
- D. Application: Treat items indicated on Drawings, and the following:
1. Wood cants, nailers, curbs, equipment support bases, blocking, stripping, and similar members in connection with roofing, flashing, vapor barriers, and waterproofing.

2.3 FIRE-RETARDANT-TREATED MATERIALS

- A. General: Where fire-retardant-treated materials are indicated, use materials complying with requirements in this article, that are acceptable to authorities having jurisdiction, and with fire-test-response characteristics specified as determined by testing identical products per test method indicated by a qualified testing agency.

Weedsport Addition to Maintenance Section and Roof Replacement, MP 304.2

- B. Fire-Retardant-Treated Lumber and Plywood by Pressure Process: Products with a flame spread index of 25 or less when tested according to ASTM E 84, and with no evidence of significant progressive combustion when the test is extended an additional 20 minutes, and with the flame front not extending more than 10.5 feet beyond the centerline of the burners at any time during the test.
1. Use treatment that does not promote corrosion of metal fasteners.
 2. Interior Type A: Treated materials shall have a moisture content of 28 percent or less when tested according to ASTM D 3201 at 92 percent relative humidity. Use where exterior type is not indicated.
 3. Design Value Adjustment Factors: Treated lumber shall be tested according ASTM D 5664, and design value adjustment factors shall be calculated according to ASTM D 6841.
- C. Kiln-dry lumber after treatment to a maximum moisture content of 19 percent. Kiln-dry plywood after treatment to a maximum moisture content of 15 percent.
- D. Identify fire-retardant-treated wood with appropriate classification marking of testing and inspecting agency acceptable to authorities having jurisdiction.
- E. Application: Treat items indicated on Drawings, and the following:
1. Concealed blocking.
 2. Plywood backing panels.

2.4 PLYWOOD BACKING PANELS

- A. Equipment Backing Panels: DOC PS 1, Exterior, AC, fire-retardant treated, in thickness indicated or, if not indicated, not less than 3/4-inch nominal thickness.

2.5 FASTENERS

- A. General: Provide fasteners of size and type indicated that comply with requirements specified in this article for material and manufacture.
1. Where carpentry is exposed to weather, in ground contact, pressure-preservative treated, or in area of high relative humidity, provide fasteners with hot-dip zinc coating complying with ASTM A 153/A 153M or Type 304 stainless steel.
- B. Screws for Fastening to Metal Framing: ASTM C 1002 or ASTM C 954 as required for application, length as recommended by screw manufacturer for material being fastened.
- C. Lag Bolts: ASME B18.2.1.
- D. Bolts: Steel bolts complying with ASTM A 307, Grade A; with ASTM A 563 hex nuts and, where indicated, flat washers.
- E. Expansion Anchors: Anchor bolt and sleeve assembly of material indicated below with capability to sustain, without failure, a load equal to 6 times the load imposed when installed in unit masonry assemblies and equal to 4 times the load imposed when installed in concrete as determined by testing per ASTM E 488 conducted by a qualified independent testing and inspecting agency.
1. Material: Carbon-steel components, zinc plated to comply with ASTM B 633, Class Fe/Zn 5.
 2. Material: Stainless steel with bolts and nuts complying with ASTM F 593 and ASTM F 594, Alloy Group 1 or 2.

Weedsport Addition to Maintenance Section and Roof Replacement, MP 304.2

2.6 MISCELLANEOUS MATERIALS

- A. Flexible Flashing: Composite, self-adhesive, flashing product consisting of a pliable, butyl rubber or rubberized-asphalt compound, bonded to a high-density polyethylene film, aluminum foil, or spunbonded polyolefin to produce an overall thickness of not less than 0.025 inch.

PART 3 - EXECUTION

3.1 INSTALLATION, GENERAL

- A. Set carpentry to required levels and lines, with members plumb, true to line, cut, and fitted. Fit carpentry to other construction; scribe and cope as needed for accurate fit. Locate nailers, blocking, and similar supports to comply with requirements for attaching other construction.
- B. Where wood-preserved-treated lumber is installed adjacent to metal decking, install continuous flexible flashing separator between wood and metal decking.
- C. Install plywood backing panels by fastening to studs; coordinate locations with utilities requiring backing panels. Install fire-retardant treated plywood backing panels with classification marking of testing agency exposed to view.
- D. Provide blocking and framing as indicated and as required to support facing materials, fixtures, specialty items, and trim.
- E. Sort and select lumber so that natural characteristics will not interfere with installation or with fastening other materials to lumber. Do not use materials with defects that interfere with function of member or pieces that are too small to use with minimum number of joints or optimum joint arrangement.
- F. Comply with AWWA M4 for applying field treatment to cut surfaces of preservative-treated lumber.
1. Use inorganic boron for items that are continuously protected from liquid water.
 2. Use copper naphthenate for items not continuously protected from liquid water.
- G. Securely attach carpentry work to substrate by anchoring and fastening as indicated, complying with the following:
1. NES NER-272 for power-driven fasteners.
 2. Table 2304.9.1, "Fastening Schedule," in ICC's International Building Code.

3.2 WOOD BLOCKING, AND NAILER INSTALLATION

- A. Install where indicated and where required for attaching other work. Form to shapes indicated and cut as required for true line and level of attached work. Coordinate locations with other work involved.
- B. Attach items to substrates to support applied loading. Recess bolts and nuts flush with surfaces unless otherwise indicated.

END OF SECTION 0610

SECTION 064023 - INTERIOR ARCHITECTURAL WOODWORK

PART 1 - GENERAL

1.1 SUMMARY

A. Section Includes:

1. Interior standing and running trim.
2. Wood furring, blocking, shims, and hanging strips for installing interior architectural woodwork items that are not concealed within other construction.

1.2 PREINSTALLATION MEETINGS

A. Preinstallation Conference: Conduct conference at Project site.

1.3 ACTION SUBMITTALS

A. Product Data: For the following:

1. Anchors.
2. Adhesives.
3. Shop finishing materials.

B. Shop Drawings:

1. Include the following:
 - a. Dimensioned plans, elevations, and sections.
 - b. Attachment details.
2. Show large-scale details.
3. Show locations and sizes of furring, blocking, and hanging strips, including blocking and reinforcement concealed by construction and specified in other Sections.

C. Samples: For each exposed product and for each shop-applied color and finish specified.

1.4 INFORMATIONAL SUBMITTALS

A. Qualification Data: For architectural woodwork manufacturer.

B. Product Certificates: For the following:

1. Adhesives.

1.5 CLOSEOUT SUBMITTALS

A. Quality Standard Compliance Certificates: AWI Quality Certification Program certificates.

1.6 QUALITY ASSURANCE

A. Manufacturer's Certification: Licensed participant in AWI's Quality Certification Program.

B. Mockups: Build mockups to verify selections made under Sample submittals, to demonstrate aesthetic effects, and to set quality standards for materials and execution.

Weedsport Addition to Maintenance Section and Roof Replacement, MP 304.2

1. Build mockups of typical interior architectural woodwork as shown on Drawings.
2. Approval of mockups does not constitute approval of deviations from the Contract Documents contained in mockups unless Owner specifically approves such deviations by Change Order.

1.7 FIELD CONDITIONS

- A. Environmental Limitations: Do not deliver or install interior architectural woodwork until building is enclosed, wet-work is complete, and HVAC system is operating and maintaining temperature and relative humidity at levels designed for building occupants for the remainder of the construction period.
- B. Environmental Limitations: Do not deliver or install interior architectural woodwork until building is enclosed, wet-work is complete, and HVAC system is operating and maintaining temperature between 60 and 90 deg F and relative humidity between 43 and 70 percent during the remainder of the construction period.

PART 2 - PRODUCTS**2.1 ARCHITECTURAL WOODWORK, GENERAL**

- A. Quality Standard: Unless otherwise indicated, comply with the Architectural Woodwork Standards for grades of interior architectural woodwork indicated for construction, finishes, installation, and other requirements.

2.2 INTERIOR STANDING AND RUNNING TRIM FOR TRANSPARENT FINISH

- A. Architectural Woodwork Standards Grade: Premium.
- B. Hardwood Lumber:
 1. Species: Select Red Oak.
 2. Cut: Plain sliced/plain sawn.
 3. Wood Moisture Content: 8 to 13 percent.
 4. Provide split species on trim that faces areas with different wood species, matching each face of woodwork to species and cut of finish wood surfaces in areas finished. For base wider than available lumber, glue for width. Do not use veneered construction.

2.3 MISCELLANEOUS MATERIALS

- A. Furring, Blocking, Shims, and Nailers: Softwood or hardwood lumber, kiln-dried to less than 15 percent moisture content.
- B. Provide self-drilling screws for metal-framing supports, as recommended by metal-framing manufacturer.
- C. Anchors: Select material, type, size, and finish required for each substrate for secure anchorage.
 1. Provide metal expansion sleeves or expansion bolts for post-installed anchors.
 2. Use nonferrous-metal or hot-dip galvanized anchors and inserts at inside face of exterior walls and at floors.
- D. Installation Adhesive: Product recommended by fabricator for each substrate for secure anchorage.

Weedsport Addition to Maintenance Section and Roof Replacement, MP 304.2

2.4 FABRICATION

- A. Fabricate interior architectural woodwork to dimensions, profiles, and details indicated.
 - 1. Ease edges to radius indicated for the following:
 - a. Edges of Solid-Wood (Lumber) Members: 1/16 inch unless otherwise indicated.
 - b. Edges of Rails and Similar Members More Than 3/4 Inch Thick: 1/8 inch.
- B. Complete fabrication, including assembly, to maximum extent possible before shipment to Project site.
 - 1. Disassemble components only as necessary for shipment and installation.
 - 2. Where necessary for fitting at site, provide allowance for scribing, trimming, and fitting.
 - 3. Trial fit assemblies at fabrication shop that cannot be shipped completely assembled.
 - a. Install dowels, screws, bolted connectors, and other fastening devices that can be removed after trial fitting.
 - b. Verify that parts fit as intended, and check measurements of assemblies against field measurements indicated on approved Shop Drawings before disassembling for shipment.

2.5 SHOP PRIMING

- A. Preparations for Finishing: Comply with the Architectural Woodwork Standards for sanding, filling countersunk fasteners, sealing concealed surfaces, and similar preparations for finishing interior architectural woodwork, as applicable to each unit of work.
- B. Interior Architectural Woodwork for Opaque Finish: Shop prime with one coat of wood primer.
 - 1. Backpriming: Apply one coat of primer, compatible with finish coats, to concealed surfaces of woodwork.
- C. Interior Architectural Woodwork for Transparent Finish: Shop-seal concealed surfaces with required pretreatments and first coat of finish.
 - 1. Backpriming: Apply one coat of sealer, compatible with finish coats, to concealed surfaces of woodwork.

PART 3 - EXECUTION**3.1 PREPARATION**

- A. Before installation, condition interior architectural woodwork to humidity conditions in installation areas for not less than 72 hours prior to beginning of installation.
- B. Before installing interior architectural woodwork, examine shop-fabricated work for completion and complete work as required, including removal of packing and backpriming of concealed surfaces.

3.2 INSTALLATION

- A. Grade: Install interior architectural woodwork to comply with same grade as item to be installed.

Weedsport Addition to Maintenance Section and Roof Replacement, MP 304.2

- B. Assemble interior architectural woodwork and complete fabrication at Project site to the extent that it was not completed during shop fabrication.
- C. Install interior architectural woodwork level, plumb, true in line, and without distortion.
 - 1. Shim as required with concealed shims.
 - 2. Install level and plumb to a tolerance of 1/8 inch in 96 inches.
- D. Scribe and cut interior architectural woodwork to fit adjoining work, refinish cut surfaces, and repair damaged finish at cuts.
- E. Anchor interior architectural woodwork to anchors or blocking built in or directly attached to substrates.
 - 1. Use **finishing screws** for exposed fastening, countersunk and filled flush with interior architectural woodwork.
 - 2. For shop-finished items, use filler matching finish of items being installed.
- F. Standing and Running Trim:
 - 1. Install with minimum number of joints possible, using full-length pieces (from maximum length of lumber available) to greatest extent possible.
 - 2. Do not use pieces less than 36 inches long, except where shorter single-length pieces are necessary.
 - 3. Scarf running joints and stagger in adjacent and related members.
 - 4. Fill gaps, if any, between top of base and wall with plastic wood filler; sand smooth; and finish same as wood base if finished.
 - 5. Install standing and running trim with no more variation from a straight line than 1/8 inch in 96 inches.

END OF SECTION 064023

ITEM 627.0007 25**THERMAL AND MOISTURE PROTECTION****1. DESCRIPTION:**

- 1.01 Furnish all labor, materials, equipment and services necessary to complete the work as indicated on the Contract Plans and the attached Specification Summary.
- 1.02 All work shall conform to the requirements specified in Part 1 – General, of the Sections listed.

2. MATERIALS:

- 2.01 The materials shall be as specified in Part 2 – Products, of the Sections listed.

3. CONSTRUCTION DETAILS:

- 3.01 The construction details shall be as specified on Part 3 – Execution, if the Sections listed.

4. METHOD OF MEASUREMENT:

- 4.01 This item shall be measured for payment on a lump sum basis for the work completed in accordance with the Contract Documents and as directed by the Engineer.

5. BASIS OF PAYMENT:

- 5.01 Payment for this item shall be made at the lump sum bid price bid. The lump sum price bid shall include cost of furnishing all labor, material, equipment and appliances necessary to complete the work as indicated on the Contract Plans and as specified herein in the Sections listed.
- 5.02 Detailed Estimate:
 - A. Before the first certificate of payment is issued for the work under this item, submit a detailed estimate of quantities and prices for all materials, labor, and other items included under this item, which shall aggregate the contract lump sum price bid for this item. Prepare the detailed estimate in the same sequence as the Sections listed.
 - B. The detailed estimate shall be supported by such evidence, including certified copies of subcontracts, as the Engineer may require.
 - C. The detailed estimate must be approved by the Engineer who may revise it as, in his/her reasonable judgment, is necessary to make the various item conform to their true values. The value of each certificate of payment will be based on the approved detailed estimate.
- 5.03 Monthly payments will be made for this item in proportion to the total amount of work completed.

ITEM 627.0007 25**THERMAL AND MOISTURE PROTECTION****1. SPECIFICATION SUMMARY**

1.01 This Item includes the following specifications:

- A. Section 070150 PREPARATION FOR REROOFING
- B. Section 072100 THERMAL INSULATION
- C. Section 074213 METAL WALL PANELS
- D. Section 075323 EPDM ROOFING
- E. Section 076200 SHEET METAL FLASHING AND TRIM
- F. Section 077100 ROOF SPECIALTIES
- G. Section 079200 JOINT SEALANTS

1.02 This item shall include, but not be limited to, the following:

- A. Roofing components needed for the replacement of the existing roof and the construction of the new roof over the building's addition.
- B. Exterior siding for the building's addition such as metal wall panels.

SECTION 070150.19 - PREPARATION FOR REROOFING

PART 1 - GENERAL

1.1 SUMMARY

- A. Section Includes:
1. Full tear-off of roof system at areas indicated on Drawings.
 2. Removal of flashings and counterflashings.
 3. Temporary roofing.
- B. Related Requirements:
1. Division 23 Sections for HVAC equipment removal and reinstallation.
 2. Division 26 Sections for electrical equipment disconnection and reconnection.

1.2 DEFINITIONS

- A. Roofing Terminology: Refer to ASTM D 1079 and glossary in NRCA's "The NRCA Roofing and Waterproofing Manual" for definition of terms related to roofing work in this Section.
- B. Full Roof Tear-off: Removal of existing roofing system down to existing concrete deck.
- C. Remove: Detach items from existing construction and legally dispose of them off-site unless indicated to be removed and reinstalled.
- D. Existing to Remain: Existing items of construction that are not indicated to be removed.

1.3 PREINSTALLATION MEETINGS

- A. Preliminary Roofing Conference: Before starting removal Work, conduct conference at Project site.
1. Meet with Owner's Representative, Architect, Owner's insurer if applicable, testing and inspecting agency representative, roofing Installer, and installers whose work interfaces with or affects roofing, including installers of roof accessories and roof-mounted equipment.
 2. Review methods and procedures related to roofing tear-off, including, but not limited to, the following:
 - a. Reroofing preparation, including roofing system manufacturer's written instructions.
 - b. Temporary protection requirements for existing roofing system components that are to remain.
 - c. Existing roof drains and roof drainage during each stage of reroofing, and roof-drain plugging and plug removal.
 - d. Construction schedule and availability of materials, Installer's personnel, equipment, and facilities needed to avoid delays.
 - e. Existing roof deck conditions requiring Owner's Representative and Architect notification.
 - f. Condition and acceptance of existing roof deck and base flashing substrate for reuse.
 - g. Structural loading limitations of roof deck during reroofing.
 - h. Base flashings, special roofing details, drainage, penetrations, equipment curbs, and condition of other construction that affect reroofing.
 - i. HVAC shutdown and sealing of air intakes.

Weedsport Addition to Maintenance Section and Roof Replacement, MP 304.2

- j. Shutdown of fire-suppression, -protection, and -alarm and -detection systems.
- k. Asbestos removal and discovery of asbestos-containing materials.
- l. Governing regulations and requirements for insurance and certificates if applicable.
- m. Existing conditions that may require Architect notification before proceeding.

1.4 ACTION SUBMITTALS

- A. Product Data: For each type of product.
- B. Temporary Roofing Submittal: Product data and description of temporary roofing system.

1.5 INFORMATIONAL SUBMITTALS

- A. Qualification Data: For Installer.
 - 1. Include certificate that Installer is approved by warrantor of existing roofing system.
 - 2. Include certificate that Installer is licensed to perform asbestos abatement.
- B. Photographs or Videotape: Show existing conditions of existing roof construction after roofing is removed adjoining construction and site improvements, including condition of blocking and other elements to remain, that can affect reroofing.
 - 1. Submit before new Work begins.

1.6 FIELD CONDITIONS

- A. Existing Roofing System: EPDM roof over (older) layers of: foam insulation, tar paper, and screed.
- B. Owner will occupy portions of building immediately below reroofing area.
 - 1. Conduct reroofing so Owner's operations are not disrupted.
 - 2. Provide Owner with not less than 72 hours' written notice of activities that may affect Owner's operations.
 - 3. Coordinate work activities daily with Owner so Owner has adequate advance notice to place protective dust and water-leakage covers over sensitive equipment and furnishings, shut down HVAC and fire-alarm or -detection equipment if needed, and evacuate occupants from below work area.
- C. Protect building to be reroofed, adjacent buildings, walkways, site improvements, exterior plantings, and landscaping from damage or soiling from reroofing operations.
- D. Maintain access to existing walkways, corridors, and other adjacent occupied or used facilities.
- E. Conditions existing at time of inspection for bidding will be maintained by Owner as far as practical.
 - 1. Construction Drawings for existing roofing system are provided for Contractor's convenience and information, but they are not a warranty of existing conditions. They are intended to supplement rather than serve in lieu of Contractor's own investigations. Contractor is responsible for conclusions derived from existing documents.
- F. Limit construction loads on existing roof areas to remain, and existing roof areas scheduled to be reroofed to loads defined in Building Codes of NYS for uniformly distributed loads.

Weedsport Addition to Maintenance Section and Roof Replacement, MP 304.2

- G. Weather Limitations: Proceed with reroofing preparation only when existing and forecasted weather conditions permit Work to proceed without water entering existing roofing system or building.
1. Remove only as much roofing in one day as can be made watertight in the same day.
- H. Hazardous Materials: A report on the presence of hazardous materials is included in this Project Manual. Examine report to become aware of locations where hazardous materials are present.
1. Hazardous material remediation is specified elsewhere in the Contract Documents.
 2. Do not disturb hazardous materials or items suspected of containing hazardous materials except according to procedures specified elsewhere in the Contract Documents.
 3. Coordinate reroofing preparation with hazardous material remediation to prevent water from entering existing roofing system or building.

PART 2 - PRODUCTS

2.1 TEMPORARY PROTECTION MATERIALS

- A. Plywood: DOC PS 1, Grade CD, Exposure 1.
- B. OSB: DOC PS 2, Exposure 1.

2.2 TEMPORARY ROOFING MATERIALS

- A. Design and selection of materials for temporary roofing are Contractor's responsibilities. Examples of temporary roofing materials are listed below.
- B. Base Sheet: ASTM D4601/D4601M, Type II, nonperforated, asphalt-impregnated and -coated, glass-fiber sheet.
- C. Glass-Fiber Felts: ASTM D2178/D2178M, Type IV, asphalt-impregnated, glass-fiber felt.
- D. Asphalt Primer: ASTM D41/D41M.
- E. Roofing Asphalt: ASTM D312/D312M, Type III or IV.
- F. Base Sheet Fasteners: Capped head, factory-coated steel fasteners, listed in FM Approvals' RoofNav.

2.3 REPLACEMENT MATERIALS

- A. Wood blocking, curbs, and nailers are specified in Section 061053 Miscellaneous Rough Carpentry."
- B. Fasteners: Factory-coated steel fasteners with metal or plastic plates listed in FM Approvals' RoofNav, and acceptable to new roofing system manufacturer.

2.4 AUXILIARY REROOFING MATERIALS

- A. General: Use auxiliary reroofing preparation materials recommended by roofing system manufacturer for intended use and compatible with components of existing and new roofing system.

PART 3 - EXECUTION

3.1 PREPARATION

- A. Protection of In-Place Conditions:
 - 1. Maintain temporary protection and leave in place until replacement roofing has been completed. Remove temporary protection on completion of reroofing.
- B. Seal or isolate windows that may be exposed to airborne substances created in removal of existing materials.
- C. Shut off rooftop utilities and service piping before beginning the Work.
- D. Test existing roof drains to verify that they are not blocked or restricted.
 - 1. Immediately notify Owner's Representative of any blockages or restrictions.
- E. During removal operations, have sufficient and suitable materials on-site to facilitate rapid installation of temporary protection in the event of unexpected rain.
- F. Maintain roof drains in functioning condition to ensure roof drainage at end of each workday.
 - 1. Prevent debris from entering or blocking roof drains and conductors.
 - a. Use roof-drain plugs specifically designed for this purpose.
 - b. Remove roof-drain plugs at end of each workday, when no work is taking place, or when rain is forecast.
 - 2. If roof drains are temporarily blocked or unserviceable due to roofing system removal or partial installation of new roofing system, provide alternative drainage method to remove water and eliminate ponding.

3.2 ROOF TEAR-OFF

- A. Notify Owner's Representative each day of extent of roof tear-off proposed for that day and obtain authorization to proceed.
- B. Lower removed roofing materials to ground and onto lower roof levels, using dust-tight chutes or other acceptable means of removing materials from roof areas.
- C. Remove Owner's accessories from roofing.
 - 1. Disconnect and salvage existing antenna(s), coordinate temporary storage of salvaged items with Owner's representative.
 - 2. Disconnect and salvage existing condensing unit, coordinate temporary storage with Owner's Representative.
- D. Full Roof Tear-off: Where indicated on Drawings, remove existing roofing and other roofing system components down to the existing concrete deck.
 - 1. Refer to Abatement drawings for abatement scope of work.
 - 2. For roof components not requiring abatement provide the following:
 - a. Remove all layers of existing roofing.
 - b. Remove base flashings and counter flashings.
 - c. Remove perimeter edge flashing
 - d. Remove flashings at pipes, curbs, mechanical equipment, and other penetrations.

Weedsport Addition to Maintenance Section and Roof Replacement, MP 304.2

- e. Remove roof drains components indicated on Drawings to be removed.
- f. Remove wood blocking, curbs, and nailers, unless noted otherwise.
- g. Inspect wood blocking, curbs, and nailers for deterioration and damage. If wood blocking, curbs, or nailers have deteriorated, immediately notify Architect through the Owner's Representative.
- g. Remove unadhered bitumen, unadhered felts, and wet felts.

3.3 DECK PREPARATION

- A. Inspect deck after tear-off of roofing system.
- B. Refer to Section 030130 Concrete Deck Repairs.

3.4 TEMPORARY ROOFING

- A. Install approved temporary roofing over area to be reroofed as required by the project schedule.

3.5 DISPOSAL

- A. Collect demolished materials and place in containers.
 - 1. Promptly dispose of demolished materials.
 - 2. Do not allow demolished materials to accumulate on-site.
 - 3. Storage or sale of demolished items or materials on-site is not permitted.
- B. Transport and legally dispose of demolished materials off Owner's property.

END OF SECTION 070150.19

SECTION 072100 - THERMAL INSULATION

PART 1 - GENERAL

1.1 SUMMARY

- A. Section Includes:
1. Glass-fiber blanket.

1.2 ACTION SUBMITTALS

- A. Product Data: For each type of product.

1.3 INFORMATIONAL SUBMITTALS

- A. Product Test Reports: For each product, for tests performed by a qualified testing agency.
- B. Evaluation Reports: For foam-plastic insulation, from ICC-ES.

1.4 DELIVERY, STORAGE, AND HANDLING

- A. Protect insulation materials from physical damage and from deterioration due to moisture, soiling, and other sources. Store inside and in a dry location. Comply with manufacturer's written instructions for handling, storing, and protecting during installation.

1.5 GLASS-FIBER BLANKET

- A. Glass-Fiber Blanket, Unfaced: ASTM C 665, Type I; with maximum flame-spread and smoke-developed indexes of 25 and 50, respectively, per ASTM E 84; passing ASTM E 136 for combustion characteristics.
1. Manufacturers: Subject to compliance with requirements, provide products by the following:
 - a. Owens Corning.
 - 1) Product: Sound Attenuation Batt Insulation (SAB)
 - b. Thicknesses
 - 1) 3-1/2"
 - 2) 5-1/2"

1.6 MINERAL-WOOL INSULATION

- A. Recycled Content: Postconsumer recycled content plus one-half of preconsumer recycled content not less than 70 percent.

PART 2 - EXECUTION

2.1 PREPARATION

- A. Clean substrates of substances that are harmful to insulation, including removing projections capable of puncturing insulation or vapor retarders, or that interfere with insulation attachment.

Weedsport Addition to Maintenance Section and Roof Replacement, MP 304.2

2.2 INSTALLATION, GENERAL

- A. Comply with insulation manufacturer's written instructions applicable to products and applications.
- B. Install insulation that is undamaged, dry, and unsoiled and that has not been left exposed to ice, rain, or snow at any time.
- C. Extend insulation to envelop entire area to be insulated. Fit tightly around obstructions and fill voids with insulation. Remove projections that interfere with placement.
- D. Provide sizes to fit applications and selected from manufacturer's standard thicknesses, widths, and lengths. Apply single layer of insulation units unless multiple layers are otherwise shown or required to make up total thickness or to achieve R-value.

2.3 INSTALLATION OF INSULATION IN FRAMED CONSTRUCTION

- A. Blanket Insulation: Install in cavities formed by framing members according to the following requirements:
 - 1. Use insulation widths and lengths that fill the cavities formed by framing members. If more than one length is required to fill the cavities, provide lengths that will produce a snug fit between ends.
 - 2. Place insulation in cavities formed by framing members to produce a friction fit between edges of insulation and adjoining framing members.
 - 3. For metal-framed wall cavities where cavity heights exceed 96 inches, support unfaced blankets mechanically.
- B. Miscellaneous Voids: Install insulation in miscellaneous voids and cavity spaces where required to prevent gaps in insulation using the following materials:
 - 1. Glass-Fiber Insulation: Compact to approximately 40 percent of normal maximum volume equaling a density of approximately 2.5 lb/cu. ft..

2.4 PROTECTION

- A. Protect installed insulation from damage due to harmful weather exposures, physical abuse, and other causes. Provide temporary coverings or enclosures where insulation is subject to abuse and cannot be concealed and protected by permanent construction immediately after installation.

END OF SECTION 072100

SECTION 074213 – METAL WALL PANELS

PART 1 - GENERAL

1.1 SUMMARY

- A. Section includes complete system of concealed-fastener, lap-seam metal panels in the following applications:
1. Metal wall panels.

1.2 REFERENCES

- A. Reference Standards:
1. ASCE 7: Minimum Design Loads for Buildings and Other Structures.
 2. ASTM A653: Steel Sheet, Zinc Coated (Galvanized) or Zinc Iron Alloy Coated (Galvannealed) by the Hot Dip Process.
 3. ASTM A792: Steel Sheet, 55 % Aluminum Zinc Alloy Coated by the Hot Dip Process.
 4. ASTM C1371: Determination of Emittance of Materials Near Room Temperature Using Portable Emisometers.
 5. ASTM C1549: Determination of Solar Reflectance Near Ambient Temperature Using a Portable Solar Reflectometer.
 6. ASTM D523: Specular Gloss.
 7. ASTM E283: Rate of Air Leakage Through Exterior Windows, Curtain Walls, and Doors Under Specified Pressure Differences Across the Specimen.
 8. ASTM E331: Water Penetration of Exterior Windows, Skylights, Doors, and Curtain Walls by Uniform Static Air Pressure Difference.
 9. ASTM E1592: Structural Performance of Sheet Metal Roof and Siding Systems by Uniform Static Air Pressure Difference.
 10. ASTM E1918: Measuring Solar Reflectance of Horizontal and Low Sloped Surfaces in the Field.
 11. ASTM E1980: Calculating Solar Reflectance Index of Horizontal and Low Sloped Opaque Surfaces.
 12. CRRC-1 Method #1: Measuring Solar Reflectance of a Flat, Opaque, and Heterogeneous Surface Using a Portable Solar Reflectometer.
 13. SMACNA Architectural Sheet Metal Manual.

1.3 SUBMITTALS

- A. Product Data.
- B. Shop Drawings:
1. Indicate thickness and dimensions of parts, fastenings and anchoring methods, details and locations of joints, transitions and other provisions necessary for thermal expansion and contraction.
 2. Indicate locations of field- and factory-applied sealant.
- C. Samples:
1. Submit two samples, 12 inches long by full panel width, showing proposed metal thickness and seam profile.

Weedsport Addition to Maintenance Section and Roof Replacement, MP 304.2

2. Submit standard color samples of metal for Architect's selection.
- D. Manufacturer Qualifications.
 - E. Installer Qualifications: Submit list of completed projects, with names and contact information for architects and contractors.
 - F. Test Reports: Indicating compliance of products with project requirements.
 - G. Warranty Documentation.

1.4 QUALITY ASSURANCE

- A. Manufacturer Qualifications:
 1. Ten years' experience, minimum, in factory fabrication of metal panels.
 2. Manufacturer shall carry \$2,000,000 liability insurance, minimum, for metal panel system.
- B. Installer Qualifications:
 1. Three years' experience, minimum, in application of metal roof or wall panels.
 2. Five satisfactory projects with metal panel work of similar scope and complexity to Work of this Project.
- C. Product Testing Agency Qualifications: Agency compliant with ISO/IEC Standard 17025, or an accredited independent agency recognized by the International Laboratory Accreditation Cooperation Mutual Recognition Arrangement or ANSI.

1.5 DELIVERY, STORAGE, AND HANDLING

- A. Storage and Handling Requirements:
 1. Keep panels and accessory items dry.
 2. Protect against damage and discoloration.
 3. Handle panels with non-marring slings.
 4. Support panels to prevent permanent deformation.
 5. Store panels above ground, with one end elevated for drainage.
 6. Protect panels against standing water and condensation between adjacent surfaces.
 7. If panels become wet, immediately separate sheets, wipe dry with clean cloth, and keep sheets separate for air-drying.
 8. Painted panels shall be shipped with protective plastic sheeting or a strippable film coating between panels. Remove strippable film coating prior to installation. Do not allow strippable film coating to remain on panels in extreme heat, cold, or direct sunlight or other UV source.

1.6 WARRANTY

- A. Manufacturer's Warranty: Manufacturer's standard 25-year performance warranty, stating the following:
 1. Architectural fluorocarbon finish:
 - a. Will be free of fading or color change in excess of 5 Hunter delta-E units as determined by ASTM D2244-02.
 - b. Will not chalk in excess of numerical rating of 8 when measured in accordance with standard procedures specified in ASTM D4214-98 method D659.
 - c. Will not peel, crack, chip, or delaminate.
 2. Metal substrate will not rupture, fail structurally, or perforate.

Weedsport Addition to Maintenance Section and Roof Replacement, MP 304.2

- B. Installer's Warranty: Warrant panels, flashings, sealants, fasteners and accessories against defective materials and/or workmanship, covering repairs required to maintain wall panels watertight and weatherproof with normal usage for two years following Project Substantial Completion date.
1. Furnish written warranty, signed by installer.

PART 2 - PRODUCTS

2.1 SYSTEM DESCRIPTION

- A. Products: Provide the following:
1. AEP Span, a Division of ASC Profiles, LLC.; Flex Series.
- B. Performance Criteria
1. Wind Uplift: As required by ASCE 7
 2. Panel system shall be ASTM E1592 tested under the supervision of an ANSI or ISO/IEC accredited laboratory and the laboratory shall issue the test report. Test data based on ASTM E330 is not acceptable.
 3. Deflection Limits: Withstand wind loads with deflections no greater than 1/180 of the span.
 4. Air Infiltration: 0.01 cfm/lf, maximum at a static difference of 6.24 psf when tested with sidelap sealant per ASTM E283.
 5. Water Penetration Under Static Pressure: No leakage at 20 psf when tested with sidelap sealant per ASTM E331.
 6. Thermal Movements: Accommodate thermal movement without buckling, joint opening, failure of connections, or other detrimental effects, through the following temperature changes:
 - a. 120 degrees F, ambient.
 - b. 180 degrees F, surface.

2.2 PANELS

- A. Panel: AEP Span, a Division of ASC Profiles, LLC; Flex Series
- B. Material: Steel conforming to ASTM A792.
1. 22 Gauge: Yield strength 50,000 psi; with aluminum-zinc alloy coating conforming to ASTM A792, Class AZ50.
- C. Profile and Pattern:
1. 10" rib with 2" reveal, 1.2FX20-12 (1 ¼" rib height)

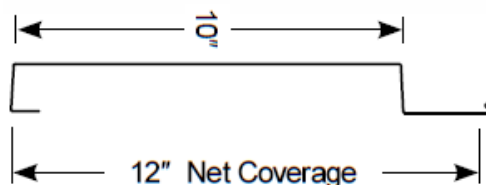

Weedsport Addition to Maintenance Section and Roof Replacement, MP 304.2

2. Panel to substrate attachment: Clip Attached

D. Finishes:

1. Exterior Panel Finish: Provide primer and finish coat on exposed faces; provide primer on concealed faces of panels.
 - a. DuraTech® 5000: Polyvinylidene Fluoride, full 70 percent Kynar 500/Hylar 5000, consisting of a baked-on 0.15-0.20 mil corrosion resistant primer and a baked-on 0.70-0.80 mil finish coat with a specular gloss of 8 to 15 when tested in accordance with ASTM D523 at 60 degrees.
 - b. Exterior Panel Color: Sage Green.
2. Interior Panel Finish: Corrosion-resistant primer; primer coat dry film thickness: 0.15 mils; polyester paint; dry film thickness of 0.35 mils, off-white to light gray in color.

E. Sustainability Characteristics:

1. Recycled Content: 27 percent post-consumer recycled content.
2. Solar Performance:
 - a. Solar reflective index (SRI): Not less than 29 per ASTM E1980.

F. Manufacturing Characteristics: Provide panels complying with provisions of Buy American Act 41 U.S. C 10a - 10d.

2.3 ACCESSORIES

A. Clip: Panel clip with pre-drilled holes attachment holes at one end and panel hook at other end, sized to fit panels.

1. Product: AEP Span; Flex Series Flush Mount Clip.
 - a. Material: 18 gauge (.0438 Min.), 40ksi yield min., G90 galvanized, material in conformance with ASTM A-653 Class G90.
 - b. Panel clips to be of proper design to resist uplift forces and reduce permanent deflection of panel assembly under design loads. Panel system manufacturer to provide proof that this has been addressed through use of clip strengthening ribs, short clip reach, or similar.

B. Trims and Flashings: Material, metal thickness, and finish to match panels. Profiles indicated in Drawings.

C. Panel Penetration Flashings: As recommended by panel manufacturer.

D. Fasteners: Per manufacturer recommendation.

E. Profile Closures: Polyethylene foam, die-cut or formed to panel configuration.

F. Sealant for Field Application: See Section 07 92 00 "Joint Sealants".

2.4 FABRICATION

A. Fabrication, General:

1. Unless otherwise shown on Drawings or specified herein, fabricate panels in continuous lengths and fabricate flashings and accessories in longest practical lengths.
2. Panels shall be factory correctively-leveled.

B. Fabrication Tolerances:

1. Flat metal surfaces will display waviness commonly referred to as "oil canning". This is caused by steel mill tolerances and is a characteristic, not a defect, of panels manufactured

Weedsport Addition to Maintenance Section and Roof Replacement, MP 304.2

from light gauge metal. Panels are factory correctively-leveled to minimize the occurrence of "oil canning". As such, "oil canning" will not be accepted as cause for rejection.

PART 3 - EXECUTION

3.1 EXAMINATION

- A. Verification of Conditions: With Installer present.
 - 1. Examine conditions and substrates on which metal panels are to be installed. Structural support or substrate shall be flat and plumb to avoid panel stresses and distortion.
 - 2. Prior to starting work, correct defects.
- B. Field Measurements:
 - 1. Coordinate field measurements and fabrication schedule with construction progress.
 - 2. Field measure prior to fabrication. Show recorded dimensions on shop drawings, including locations of shop-fabricated openings.
 - 3. If field measurements differ from drawing dimensions, notify Architect prior to fabrication.
- C. Framing and Substrate Tolerances: Deviations from flat plane shall not exceed the following.
 - 1. 1/4 inch in 20 feet vertically or horizontally.
 - 2. 1/8 inch in 5 feet.

3.2 PREPARATION

- A. Protection:
 - 1. Treat contacting surfaces of dissimilar materials to prevent electrolytic corrosion.
 - 2. Where panels or trim may come in contact with dissimilar materials or treated lumber, fabricate transitions to facilitate drainage and minimize possibility of galvanic corrosion.
 - 3. At points of contact with dissimilar metal or treated lumber, coat panel or trim with protective paint or separate materials with a weatherproof underlayment.
 - 4. Direct contact or run-off from CCA, ACQ, AC, or other treated lumber (outdoor wood) or fire retardant impregnated or treated wood shakes or siding can cause panels and trim to fail prematurely. Avoid contact with these materials.

3.3 INSTALLATION

- A. Secondary Framing: Install according to approved shop drawings and metal panel manufacturer's recommendations.
- B. Panels and Flashing:
 - 1. Install according to approved shop drawings.
 - 2. Comply with methods and recommendations of SMACNA Architectural Sheet Metal Manual for flashing configurations required.
 - 3. Overlap flashing at least 6 inches.
 - 4. Discrepancies between job site conditions and shop drawings shall be brought to the attention of the Architect for resolution.
 - 5. Cutting and Fitting:
 - a. Cut panels neat, square, and true with shearing action cutters. Torch or power saw cutting is prohibited.

Weedsport Addition to Maintenance Section and Roof Replacement, MP 304.2

- b. Openings 6 inches and larger: Shop fabricate and reinforce to maintain original load capacity.
- c. Openings less than 6 inches: Field cutting is acceptable.
- C. Accessories: Install trims, panel closures, flashings according to Drawings and manufacturer's recommended details.
- D. Sealant Installation: Apply according to approved shop drawings and SMACNA Architectural Sheet Metal Manual recommendations.
- E. Installation Tolerances: Match dimensional tolerances of framing or substrate.

3.4 CLEANING

- A. Repairs:
 - 1. Touch up paint is not required for panels with scratches that do not expose metal.
 - 2. Panels or flashings with finish damage exposing metal or with substrate damage shall be replaced.
- B. Cleaning and Waste Management: At completion of each day's work and at work completion, sweep panels, flashings, and gutters clean. Do not allow fasteners, cuttings, filings, or scraps to accumulate.

END OF SECTION

SECTION 075323 - ETHYLENE-PROPYLENE-DIENE-MONOMER (EPDM) ROOFING

PART 1 - GENERAL

1.1 DESCRIPTION

- A. The Project is located in Weedsport, N.Y.
- B. The project consists of installing Fully Adhered EPDM Roofing System with a 20 Year Total Systems Warranty as outlined below.
- C. Basis-of-Design System: Carlisle.
- D. **Metal Deck Areas:** Mechanically fasten 1/2" Carlisle Securock to meet the required uplift ratings but no less than 1 every 2 sq. ft. in the field and perimeter and 1 every 1 sq. ft. in the corners. Prime the substrate board with NYS VOC OTC compliant primer, Carlisle Cav-Grip. Install Carlisle VapAir Seal 725 TR vapor retarder. Adhesively attach Carlisle Polyisocyanurate insulation and Carlisle water resistant 3/8" Securock gypsum overlayment board with Carlisle Fast adhesive 4" on center in the field, perimeter & corners. Insulation must meet minimum R-30 to meet code. Fully adhere Carlisle .060 non-reinforced EPDM in accordance with current specifications and details.
- E. **Concrete Deck:** Completely remove existing roofing and flashing materials down to the existing structural deck. Prime the deck with NYS VOC OTC compliant primers, Carlisle CavGrip. Install Carlisle 725TR vapor retarder. Adhesively attach Carlisle Polyisocyanurate insulation and 3/8" Securock water resistant gypsum overlayment board with Carlisle Flexible Fast adhesive 4" on center in the field, perimeter and corners. Insulation must meet minimum R-30 to meet code. Fully adhere Carlisle .060 non-reinforced EPDM in accordance with current specifications and details.
- F. Provide owner with a 20 year, 72 MPH total system edge-to-edge warranty.

1.2 EXTENT OF WORK

- A. Provide all labor, material, tools, equipment, and supervision necessary to complete the installation of a .060 inch thick non-reinforced EPDM membrane Fully Adhered Roofing System including flashings and insulation as specified herein and as indicated on the drawings in accordance with the manufacturer's most current specifications and details.
- B. The roofing contractor shall be fully knowledgeable of all requirements of the contract documents and shall make themselves aware of all job site conditions that will affect their work.
- C. The roofing contractor shall confirm all given information and advise the building owner, prior to bid, of any conflicts that will affect their cost proposal.
- D. Any contractor who intends to submit a bid using a roofing system other than the approved manufacturer must submit for pre-qualification in writing ten (10) days prior to the bid date. Any contractor who fails to submit all information as requested will be subject to rejection. Bids stating "as per plans and specs" will be unacceptable.

1.3 SUBMITTALS

- A. Prior to starting work, the roofing contractor must submit the following:
 - 1. Shop drawings showing layout, details of construction and identification of materials.
 - 2. Sample of the manufacturer's Membrane System Warranty.

Weedspport Addition to Maintenance Section and Roof Replacement, MP 304.2

3. Submit a letter of certification from the manufacturer which certifies the roofing contractor is authorized to install the manufacturer's roofing system and lists foremen who have received training from the manufacturer along with the dates training was received.
 4. Certification of the manufacturer's warranty reserve.
- B. Upon completion of the installed work, submit copies of the manufacturer's final inspection to the specifier prior to the issuance of the manufacturer's warranty.

1.4 PRODUCT DELIVERY, STORAGE AND HANDLING

- A. Deliver materials to the job site in the manufacturer's original, unopened containers or wrappings with the manufacturer's name, brand name and installation instructions intact and legible. Deliver in sufficient quantity to permit work to continue without interruption.
- B. Comply with the manufacturer's written instructions for proper material storage.
1. Store materials, except membrane, between 60°F and 80°F in dry areas protected from water and direct sunlight. If exposed to lower temperature, restore to 60°F minimum temperature before using.
 2. Store materials containing solvents in dry, well-ventilated spaces with proper fire and safety precautions. Keep lids on tight. Use before expiration of their shelf life.
- C. Insulation must be on pallets, off the ground and tightly covered with waterproof materials.
- D. Any materials which are found to be damaged shall be removed and replaced at the applicator's expense.

1.5 WORK SEQUENCE

- A. Schedule and execute work to prevent leaks and excessive traffic on completed roof sections. Care should be exercised to provide protection for the interior of the building and to ensure water does not flow beneath any completed sections of the membrane system.
- B. Do not disrupt activities in occupied spaces.

1.6 USE OF THE PREMISES

- A. Before beginning work, the roofing contractor must secure approval from the building owner's representative for the following:
1. Areas permitted for personnel parking.
 2. Access to the site.
 3. Areas permitted for storage of materials and debris.
 4. Areas permitted for the location of cranes, hoists and chutes for loading and unloading materials to and from the roof.
 5. Interior stairs or elevators may not be used for removing debris or delivering materials, except as authorized by the building superintendent.

1.7 EXISTING CONDITIONS

If discrepancies are discovered between the existing conditions and those noted on the drawings, immediately notify the owner's representative by phone and solicit the manufacturer's approval prior to commencing with the work.

1.8 TEMPORARY FACILITIES AND CONTROLS

- A. Temporary Utilities:
1. Water, power for construction purposes and lighting are not available at the site and will not be made available to the roofing contractor.
- B. Temporary Sanitary Facilities

Weedspport Addition to Maintenance Section and Roof Replacement, MP 304.2

1. Sanitary facilities will not be available at the job site. The roofing contractor shall be responsible for the provision and maintenance of portable toilets or their equal.

C. Building Site

1. The roofing contractor shall use reasonable care and responsibility to protect the building and site against damages. The contractor shall be responsible for the correction of any damage incurred as a result of the performance of the contract.
2. The roofing contractor shall remove all debris from the job site in a timely and legally acceptable manner.

D. Security

1. Obey the owner's requirements for personnel identification, inspection and other security measures.

1.9 JOB SITE PROTECTION

- A. The roofing contractor shall adequately protect building, paved areas, service drives, lawn, shrubs, trees, etc. from damage while performing the required work. Provide canvas, boards and sheet metal (properly secured) as necessary for protection and remove protection material at completion.
- B. Do not overload any portion of the building, either by use of or placement of equipment, storage of debris, or storage of materials.
- C. Protect against fire and flame spread. Maintain proper and adequate fire extinguishers.
- D. Take precautions to prevent drains from clogging during the roofing application. Remove debris at the completion of each day's work and clean drains, if required.
- E. Store moisture susceptible materials above ground and protect with waterproof coverings.

1.10 SAFETY

- A. The roofing contractor shall be responsible for all means and methods as they relate to safety and shall comply with all applicable local, state and federal requirements that are safety related. **Safety shall be the responsibility of the roofing contractor.** All related personnel shall be instructed daily to be mindful of the full time requirement to maintain a safe environment for the facility's occupants including staff, visitors, customers and the occurrence of the general public on or near the site.

1.11 WORKMANSHIP

- A. Applicators installing the new roof, flashing and related work shall be factory trained and approved by the membrane manufacturer.
- B. All work shall be of highest quality and in strict accordance with the manufacturer's published specifications and to the building owner's satisfaction.
- C. There shall be a supervisor on the job site at all times while work is in progress.

1.12 QUALITY ASSURANCE

- A. The EPDM membrane roofing system must achieve a UL Class A rating and be installed to Factory Mutual standards.
- B. The specified roofing assembly must have been successfully tested by a qualified testing agency (ANSI/FM 44747) to resist the design uplift pressures calculated according to state adopted agency:
 1. American Society of Civil Engineers (ASCE 7)
 2. International Building Code (IBC)

Weedspport Addition to Maintenance Section and Roof Replacement, MP 304.2

3. Minimum accepted assembly uplift rating is 90-lbs/sqft

- C. The manufacturer must have a minimum of 20 (twenty) years experience in the manufacturing of vulcanized thermal set sheeting and must be the primary manufacturer of the EPDM membrane, membrane adhesives and membrane accessories. Secondary “marketers” of roofing systems will not be acceptable. The manufacturer must have warranty reserve fund. Evidence of this requirement shall be submitted in accordance with section 1.03.
- D. The roofing system must be installed by an applicator authorized and trained by the manufacturer in compliance with shop drawings as approved by the manufacturer. The roofing applicator shall be thoroughly experienced and upon request be able to provide evidence of having at least 10 (ten) years successful experience installing single-ply EPDM roofing systems and having installed at least 10 (ten) roofing applications of similar or equal scope. Roofing contractors must have a working office and warehouse location within 200 miles of project location to ensure prompt service of any potential issues or emergencies. Unless otherwise noted in this specification, the roofing contractor must strictly comply with the manufacturer's current specifications and details.
- E. Provide adequate number of experienced workmen regularly engaged in this type of work who are skilled in the application techniques of the materials specified. Provide at least one thoroughly trained and experienced superintendent on the job at all times roofing work is in progress.

Provide weekly inspections and provide written documentation to architect by a full time non-sales technical representative of membrane manufacturer or by a Registered Roof Observer.

- F. There shall be no deviations made from this specification or the approved shop drawings without the prior written approval of the specifier. Any deviation from the manufacturer's installation procedures must be supported by a written certification on the manufacturer's letterhead and presented for the specifier's consideration.
- G. Upon completion of the installation, the applicator shall arrange for an inspection to be made by a non-sales technical representative of the membrane manufacturer in order to determine whether or not corrective work will be required before the warranty will be issued. Notify the building owner seventy-two (72) hours prior to the manufacturer's final inspection.

1.13 JOB CONDITIONS, CAUTIONS AND WARNINGS

- A. Material Safety Data Sheets (MSDS) must be on location at all times during the transportation, storage and application of materials.
- B. When positioning membrane sheets, exercise care to locate all field splices away from low spots and out of drain sumps. All field splices should be shingled to prevent bucking of water.
- C. When loading materials onto the roof, the Carlisle Authorized Roofing Applicator must comply with the requirements of the building owner to prevent overloading and possible disturbance to the building structure.
- D. Proceed with roofing work only when weather conditions are in compliance with the manufacturer's recommended limitations, and when conditions will permit the work to proceed in accordance with the manufacturer's requirements and recommendations.
- E. Proceed with work so new roofing materials are not subject to construction traffic. When necessary, new roof sections shall be protected and inspected upon completion for possible damage.
- F. Provide protection, such as 3/4-inch thick plywood, for all roof areas exposed to traffic during construction. Plywood must be smooth and free of fasteners and splinters.

Weedspport Addition to Maintenance Section and Roof Replacement, MP 304.2

- G. The surface on which the insulation or roofing membrane is to be applied shall be clean, smooth, dry, and free of projections or contaminants that would prevent proper application of or be incompatible with the new installation, such as fins, sharp edges, foreign materials, oil and grease.
- H. New roofing shall be complete and weathertight at the end of the workday.
- I. Contaminants such as grease, fats and oils shall not be allowed to come in direct contact with the roofing membrane.

1.14 WARRANTY

- A. Provide manufacturer's 20 year Edge-to-Edge Total System Warranty covering both labor and material with no dollar limitation. The maximum wind speed coverage shall be peak gusts of 72 mph measured at 10 meters above ground level. Certification is required with submittals indicating the manufacturer has reviewed and agreed to such wind coverage. All products including substrate boards, vapor retarders, insulation, fasteners, fastening plates and edgings must be manufactured and/or supplied by the roofing system manufacturer and covered by the warranty.
- B. Pro-rated Warranties shall not be accepted.
- C. Evidence of the manufacturer's warranty reserve shall be included as part of the project submittals for the specifier's approval.

PART 2 - PRODUCTS**2.1 GENERAL**

- A. Roofing system is based upon the products of Carlisle SynTec Incorporated. Acceptable manufacturers are listed below:
 - 1. Carlisle Syntec (basis of design)
 - 2. Approved equal
- B. All products including substrate boards, vapor retarders, insulation, fasteners, fastening plates and edgings must be manufactured and/or supplied by the roofing system manufacturer and covered by the warranty.

2.2 MEMBRANE

- A. Furnish Carlisle .060 inch thick non-reinforced EPDM. The membrane shall conform to the minimum physical properties of ASTM D4637, or equal. When a 10-foot wide membrane is to be used, the membrane shall be manufactured in a single panel with no factory splices to reduce splice intersections with 6 inch factory applied tape. No substitutions will be considered unless written request for approval has been submitted and approved by the architect no less than ten days prior to the bid date.

2.3 UNDERLAYMENT and OVERLAYMENT BOARD

- A. Insulation underlayment board on metal deck areas shall be ½" Carlisle Securock. Insulation overlayment board shall be minimum 3/8" Carlisle Securock. Boards shall be an impact resistant, non-structural, fiber reinforced gypsum panel manufactured with 95% certified recycle content and moisture and mold resistance throughout the panel core and surface; manufactured to conform to ASTM C1278.

2.4 INSULATION

- A. Flat Insulation areas shall be Carlisle Insulbase polyisocyanurate and shall be minimum R-30 as per 2014 ASTM C1289, (LTTR).

Weedsport Addition to Maintenance Section and Roof Replacement, MP 304.2

- B. Tapered Insulation and crickets shall be Carlisle Insulbase Polyisocyanurate as supplied by Carlisle SynTec Incorporated (or the membrane manufacturers') as shown on drawings, with a minimum average R value of 30 as per 2014 ASTM C1289, (LTTR). Insulation transitions/step offs greater than ½" will require a transition board such as a wood fiberboard tapered edge strip.
- C. All Polyisocyanurate shall be as per ASTM 1289 Type II, Class 1, Grade 2, 20 PSI minimum.

2.5 VAPOR RETARDER / TEMPORARY ROOF

- A. Vapor retarder is a minimum 40 mil composite sheet consisting of a self-adhering rubberized asphalt membrane. The underlayment board shall be primed with Low VOC Carlisle Cav-Grip in accordance with manufacturer's specifications. Vapor retarder must have a perm rating of 0.05 or less as per ASTM E90. Vapor retarder must be rated by the manufacturer as a temporary roof with an allowable exposure to the elements for 90 days.

2.6 ADHESIVES AND CLEANERS

- A. All products shall be furnished by the membrane manufacturer and specifically formulated for the intended purpose. **All primers and adhesives must comply with NYS VOC OTC regulations.**
 1. Bonding Adhesive: Low VOC (**Membrane Adhesive must be manufactured by the Primary membrane manufacturer to ensure compatibility**)
 2. Splice Tape and Primer: Sure-Seal 6 inch SecurTAPE and Low VOC EPDM Primer
 3. Cleaning Solvent: Sure-Seal Weathered Membrane Cleaner
 4. External seam sealant: Sure-Seal Lap Sealant (**To be used on all field and flashing splices.**)
 5. Sealer: Sure-Seal Pourable Sealer
 6. Insulation & Overlayment adhesive: Flexible FAST Adhesive - Insulation adhesive must be V.O.C. free and be a 2 part low rise foam adhesive with 100% adhesion. (**Ribbon method adhesives are acceptable. Bead spacing shall be 4 inches on center in the field, perimeters and corners.**)

2.7 FASTENERS AND PLATES

- A. To be used for mechanical attachment of the underlayment board into the metal deck and to provide additional membrane securement:
 1. **HP Fasteners:** a threaded, black epoxy electro-deposition coated fastener used with steel and wood roof decks.
 2. **InsulFast Fasteners:** A threaded #12 fastener with #3 phillips head used for insulation and underlayment board attachment into steel or wood decks.
 3. **Hammer Screw:** an expansion anchor with stainless steel drive pin used for fastening the Sure-Seal Termination Bar or Seam Fastening Plates to concrete, brick, or block walls.
 4. **HP 14-10 Fasteners:** A #14 threaded fastener used for minimum 3,000 psi concrete decks.
 5. **Insulation Fastening Plates:** a nominal 3 inch diameter plastic or metal plate used for insulation attachment in conjunction with HP Fasteners or Concrete Spikes.
 6. **Seam Fastening Plates:** a 2 inch diameter steel, FM approved metal plate used in conjunction with RUSS or with EPDM membrane for membrane securement.
 7. **RUSS (Reinforced Universal Securement Strip):** a 6 or 9 inch wide, 100 foot long strip of reinforced EPDM membrane.
 - a. The **6 inch wide RUSS** shall be utilized horizontally or vertically (in conjunction with Seam Fastening Plates) below the EPDM membrane for additional membrane securement.
 - b. The **9 inch wide RUSS** shall be utilized in conjunction with metal edgings to allow the continuation of the EPDM deck membrane as flashing at all corner areas (20 foot in each direction) in accordance with details.

2.8 METAL EDGING AND MEMBRANE TERMINATIONS

- A. All metal edging shall be Factory Mutual Approved. All wood blocking shall be installed as per FM 1-49.
- B. METAL EDGE QUALITY ASSURANCE: High performance gravel stop shall be CERTIFIED by the gravel stop manufacturer to comply with ANSI/SPRI Standard ES-1-98. Roof edge/gravelstop shall meet performance design criteria according to the following test standards:
1. ANSI/SPRI ES-1-98 Test Method RE-1 Test for Roof Edge Termination of Single-ply Roofing Membranes: The fascia system shall be tested to secure the membrane to minimum 100 lbs/ft in accord with the ANSI/SPRI ES-1-98 Test Method RE-1. Use the current edition of ANSI/SPRI ES-1 Wind Design Standard for Edge Systems Used with Low Slope Roofing Systems.
 2. ANSI/SPRI ES-1-98 Test Method RE-2 Pull-Off Test for Fascia: The fascia system shall be tested in accord with the ANSI/SPRI ES-1-98 Test Method RE-2. Use the current edition of ANSI/SPRI ES-1 Wind Design Standard for Edge Systems Used with Low Slope Roofing Systems.
 3. FMRC Loss Prevention Data Sheet 1-49 "Perimeter Flashing." The fascia product shall be listed in current Factory Mutual Research Corporation Approval Guide.
- C. **SecurEdge 2000 Fascia / Gravel Stop:** a snap-on edge system consisting of an extruded aluminum base anchor and .050" aluminum fascia. Installed as per Carlisle detail U-1C similar with 6 inch seam tape. Color chosen by owner from standard color range.
- D. **SecurEdge 300 Coping:** incorporates a 20 gauge anchor cleat with 4 pre-slotted holes, a concealed joint cover and 10 foot continuous sections of coping cap; can accommodate minimum 5 inch wide parapet walls. Metal coping shall be .050 aluminum and the color shall be a standard Kynar color or as noted on drawings. **The required metal edge detail for this project shall be Carlisle Detail U-9F.**
- E. **Termination Bar:** a 1 inch wide and .098 inch thick extruded aluminum bar pre-punched 6 inches on center; incorporates a sealant ledge to support Lap Sealant and provide increased stability for membrane terminations. **The required metal edge detail for this project shall be Carlisle Detail U-9A.**
- F. **Fascia / drip edge:** an edge system consisting of a 26 gauge galvanized metal wind cleat and .050 inch thick aluminum fascia. **The required metal edge detail for this project shall be Carlisle Detail U-1D.1 Option 1.**
- G. **Wood blocking to be installed as per FM 1-49.**

2.9 WALKWAYS

- A. Protective surfacing for roof traffic shall be Sure-Seal Walkway Pads (30" x 30" molded black rubber with factory rounded corners) adhered to the EPDM membrane roof with Splice Tape.

PART 3 - EXECUTION**3.1 GENERAL**

- A. Comply with the manufacturer's published instructions for the installation of the membrane roofing system including proper substrate preparation, jobsite considerations and weather restrictions. All roofing products must be installed complete each day. Phased applications are not acceptable.
- B. Position sheets to accommodate contours of the roof deck and shingle splices to avoid bucking water.

3.2 UNDERLAYMENT BOARD ATTACHMENT ON METAL DECK AREAS ONLY

- A. Mechanically attach the 1/2" Carlisle Securock to meet the required uplift ratings but no less than one fastener per 2 square feet in the field and perimeter of the roof system and one per 1 square foot in the corners. **Mechanically fasten the underlayment board thru the top flutes only careful not to penetrate the low flutes.**

3.3 VAPOR BARRIER APPLICATION

- A. Surfaces to receive Carlisle 725 TR Air and Vapor Barrier must be clean and dry. Blow off and broom off any loose debris. Prime all surfaces to receive the vapor retarder with a NYS VOC OTC compliant primer, Low VOC CCW-702 Primer or Cav-Grip. Apply the primer with a long nap roller at the applicable coverage rate noted above. At 75° F allow primer to dry 1 hour minimum. If the Cav-Grip is being used; spray apply in a thin even coat at a rate of 2,000 - 2,500 square feet per cylinder. Apply Cav-Grip in a thin, even coat to substrate. Avoid high thickness buildup. Keep spray gun perpendicular to surface during spray. Set time for the Cav-Grip should be approximately 5 minutes. Primers have a satisfactory cure when it will not transfer when touched. Prime only areas to be waterproofed the same day. Reprime if area becomes dirty. Apply Carlisle 725TR Air and Vapor Barrier from low to high point, in a shingle fashion, so that laps will shed water. Overlap all edges at least 2-1/2 inches. End laps shall be staggered. Place membrane carefully so as to avoid wrinkles and fishmouths. Immediately after installation, roll with a 100-150 pound weighted steel roller. There shall be no gaps in the vapor barrier application.

3.4 INSULATION and OVERLAYMENT BOARD ATTACHMENT

- A. Secure all insulation, staggering all joints, to the Vapor Retarder with the Flexible FAST Adhesive in accordance with the manufacturer's specifications and application procedures. Insulation adhesive must be a 2 part low rise foam adhesive with 100% adhesion. Apply the overlayment board with the same adhesive application requirements. **(Ribbon method adhesives are acceptable. Bead spacing shall be 4 inches on center in the field, perimeters and corners.) Strict care must be taken to make sure that all insulation and cover boards lay flat and are in an even plane with adjacent boards.** **(Caution: Do not apply urethane adhesives to unweathered asphalt, new or residual.)**
1. Allow Flexible FAST adhesive to rise approximately 1/8" and develop a string/body (approximately 1.5-2 min). String time will vary based on environmental conditions like temperature and humidity. String time is measured by touching the adhesive with a splice wipe and looking for development of "strings" of adhesive as you pull the splice wipe out of the adhesive. Do not allow the adhesive to over-cure prior to setting the roof boards.
 2. When installing full spray or beads do not allow the foam installation pattern to exceed the width of the board being installed. Exceeding the width of the roof board will cause an uneven application of the adjacent board due to the rising foam. (See Carlisle Detail A-27G for 4" bead spacing.)
 3. Walk the boards into the adhesive **and** roll using a 30" wide, 150 pound weighted steel roller to ensure full embedment. Optimal set up time should be approximately 5 to 7 minutes. (Caution: walking on the boards immediately after placement in adhesive can cause slippage/movement until the adhesive has started to set. When walking the boards in, relief cuts may be necessary to allow a lifted board to lay flat, constant weight may be required to achieve adequate adhesion.)

3.5 MEMBRANE PLACEMENT AND BONDING

- A. Unroll and position membrane without stretching. Allow the membrane to relax for approximately 1/2 hour before bonding. Fold the sheet back onto itself so half the underside of the membrane is exposed.

Weedspport Addition to Maintenance Section and Roof Replacement, MP 304.2

- B. Apply the Bonding Adhesive in accordance with the manufacturer's published instructions, to both the underside of the membrane and the substrate. Allow the adhesive to dry until it is tacky but will not string or stick to a dry finger touch.
 1. Roll the coated membrane into the coated substrate while avoiding wrinkles. Brush down the bonded half of the membrane sheet with a soft bristle push broom to achieve maximum contact.
 2. Fold back the unbonded half of the membrane sheet and repeat the bonding procedure.
- C. Install adjoining membrane sheets in the same manner, overlapping edges approximately 7 inches. Do not apply bonding adhesive to the splice area.
- D. Strict care must be taken to make sure that bonding adhesive and bonding adhesive can stains are prevented on the finished roof membrane. Any short or long term storage of metal containers that can rust will require a separator sheet on the finished roof membrane.

3.6 MEMBRANE SPLICING: 6 inch pre-applied Splice Tape is required for this project: All details and splice procedures as per 25 & 30 Year Warranty specifications, no exceptions or deviations.

- A. Overlap adjacent sheets and mark a line 1/2 inch out from the top sheet.
- B. Fold the top sheet back and clean the dry splice area (minimum 6 inches wide) of membrane with Sure-Seal Primer as required by the membrane manufacturer.
- C. Apply Primer to the EPDM sheet. Press Membrane and tape onto the sheet using hand pressure.
- D. Remove the release film and press the top sheet onto the tape using hand pressure.
- E. Roll the seam toward the splice edge with a 2 inch wide steel roller.
- F. Splice intersections are to be overlaid with a layer of 6" X 6" **and** a 12" X 12" Pressure-Sensitive flashing.
- G. **All field and flashing splices are to be sealed with Lap Sealant and installed per Carlisle detail U-2A.1, option 2.**

3.7 FLASHING

- A. Wall and curb flashing shall be cured EPDM membrane. Continue the deck membrane as wall flashing where practical. All outside corners shall be as per Carlisle detail U-15G.1.
- B. Follow manufacturer's typical flashing procedures for all wall, curb, and penetration flashing including metal edging/coping and roof drain applications.
- C. The fascia edge detail must be installed in accordance with Carlisle detail U-1C.
- D. All wall terminations shall be as per Carlisle Detail U-9A.
- E. Base wall flashing shall be as per Carlisle Detail U-2C.

3.8 WALKWAYS

- A. Install walkways at all traffic concentration points (such as roof hatches, access doors, rooftop ladders, etc.) and all locations as identified on the specifier's drawing.
- B. Adhere walkways pads to the EPDM membrane in accordance with the manufacturer's specifications.

3.9 DAILY SEAL

- A. On phased roofing, when the completion of flashings and terminations is not achieved by the end of the work day, a daily seal must be performed to temporarily close the membrane to prevent water infiltration.

Weedsport Addition to Maintenance Section and Roof Replacement, MP 304.2

- B. Use Sure-Seal Pourable Sealer or other acceptable membrane seal in accordance with the manufacturer's requirements.

3.10 CLEAN UP

- A. Perform daily clean-up to collect all wrappings, empty containers, paper, and other debris from the project site. Upon completion, all debris must be disposed of in a legally acceptable manner.
- B. Prior to the manufacturer's inspection for warranty, the applicator must perform a pre-inspection to review all work and to verify all flashing has been completed as well as the application of all caulking.

END OF SECTION 075323

SECTION 076200 - SHEET METAL FLASHING AND TRIM

PART 1 - GENERAL

1.1 SUMMARY

- A. Section Includes:
1. Manufactured Products:
 - a. Manufactured reglets.
 2. Formed Products:
 - a. Formed miscellaneous flashings.

1.2 PERFORMANCE REQUIREMENTS

- A. General: Sheet metal flashing and trim assemblies as indicated shall withstand wind loads, structural movement, thermally induced movement, and exposure to weather without failure due to defective manufacture, fabrication, installation, or other defects in construction. Completed sheet metal flashing and trim shall not rattle, leak, or loosen, and shall remain watertight.
- B. Metal Edge Securement: Install in accordance with ANSI/SPRI ES-1, "American National Standard for Edge Systems Used with Low-Slope Roofing Systems."
- C. Thermal Movements: Provide sheet metal flashing and trim that allows for thermal movements from ambient and surface temperature changes.
1. Temperature Change (Range): 120 deg F, ambient; 180 deg F, material surfaces.

1.3 SUBMITTALS

- A. Product Data: For each type of product indicated. Include construction details, material descriptions, dimensions of individual components and profiles, and finishes for each manufactured product and accessory.
- B. Shop Drawings: Show fabrication and installation layouts of sheet metal flashing and trim, including plans, elevations, expansion-joint locations, and keyed details. Distinguish between shop- and field-assembled work. Include the following:
1. Identification of material, thickness, weight, and finish for each item and location in Project.
 2. Details for forming sheet metal flashing and trim, including profiles, shapes, seams, and dimensions.
 3. Details for joining, supporting, and securing sheet metal flashing and trim, including layout of fasteners, cleats, clips, and other attachments. Include pattern of seams.
 4. Details of termination points and assemblies, including fixed points.
 5. Details of expansion joints and expansion-joint covers, including showing direction of expansion and contraction.
 6. Details of edge conditions, including eaves, ridges, valleys, rakes, crickets, and counterflashings as applicable.
 7. Details of special conditions.
 8. Details of connections to adjoining work.
- C. Samples for Initial Selection: For each type of sheet metal flashing, trim, and accessory indicated with factory-applied color finishes involving color selection.
- D. Qualification Data: For qualified fabricator.

Weedsport Addition to Maintenance Section and Roof Replacement, MP 304.2

- E. Maintenance Data: For sheet metal flashing, trim, and accessories to include in maintenance manuals.
- F. Warranty: Sample of special warranty.

1.4 QUALITY ASSURANCE

- A. Fabricator Qualifications: Shop that employs skilled workers who custom fabricate sheet metal flashing and trim similar to that required for this Project and whose products have a record of successful in-service performance.
- B. Sheet Metal Flashing and Trim Standard: Comply with SMACNA's "Architectural Sheet Metal Manual" unless more stringent requirements are specified or shown on Drawings.

1.5 DELIVERY, STORAGE, AND HANDLING

- A. Do not store sheet metal flashing and trim materials in contact with other materials that might cause staining, denting, or other surface damage. Store sheet metal flashing and trim materials away from uncured concrete and masonry.
- B. Protect strippable protective covering on sheet metal flashing and trim from exposure to sunlight and high humidity, except to the extent necessary for the period of sheet metal flashing and trim installation.

1.6 WARRANTY

- A. Special Warranty on Finishes: Manufacturer's standard form in which manufacturer agrees to repair finish or replace sheet metal flashing and trim that shows evidence of deterioration of factory-applied finishes within specified warranty period.
 - 1. Exposed Panel Finish: Deterioration includes, but is not limited to, the following:
 - a. Color fading more than 5 Hunter units when tested according to ASTM D 2244.
 - b. Chalking in excess of a No. 8 rating when tested according to ASTM D 4214.
 - c. Cracking, checking, peeling, or failure of paint to adhere to bare metal.
 - 2. Finish Warranty Period: 10 years from date of Substantial Completion.

PART 2 - PRODUCTS**2.1 SHEET METALS**

- A. General: Protect mechanical and other finishes on exposed surfaces from damage by applying a strippable, temporary protective film before shipping.
- B. Aluminum Sheet: ASTM B 209, alloy as standard with manufacturer for finish required, with temper as required to suit forming operations and performance required.
 - 1. Surface: Smooth, flat.
 - 2. Exposed Coil-Coated Finishes:
 - a. Two-Coat Fluoropolymer: AAMA 620. Fluoropolymer finish containing not less than 70 percent PVDF resin by weight in color coat. Prepare, pretreat, and apply coating to exposed metal surfaces to comply with coating and resin manufacturers' written instructions.
 - 3. Color: As selected by Architect from manufacturer's full range.

Weedsport Addition to Maintenance Section and Roof Replacement, MP 304.2

4. Concealed Finish: Pretreat with manufacturer's standard white or light-colored acrylic or polyester backer finish, consisting of prime coat and wash coat with a minimum total dry film thickness of 0.5 mil.
- C. Stainless-Steel Sheet: ASTM A 240 or ASTM A 666, Type 304, dead soft, fully annealed.
1. Finish: 2D (dull, cold rolled).
 2. Surface: Smooth, flat.
- D. Copper Sheet: ASTM B370, cold-rolled copper sheet, H00 or H01 temper.
1. Source Limitations: Obtain sheet from single source from single manufacturer.
 2. Non-patinated, Exposed Finish: Mill.
 3. **16 oz./sq. ft.**
- E. Lead Sheet: ASTM B749 lead sheet

2.2 UNDERLAYMENT MATERIALS

- A. Felt: ASTM D 226, Type II (No. 30), asphalt-saturated organic felt, nonperforated.
- B. Self-Adhering, High-Temperature Sheet: Minimum 30 to 40 mils thick, consisting of slip-resisting polyethylene-film top surface laminated to layer of butyl or SBS-modified asphalt adhesive, with release-paper backing; cold applied. Provide primer when recommended by underlayment manufacturer.
1. Thermal Stability: ASTM D 1970; stable after testing at 240 deg F.
 2. Low-Temperature Flexibility: ASTM D 1970; passes after testing at minus 20 deg F.
 3. Products: Subject to compliance with requirements, provide one of the following:
 - a. Carlisle Coatings & Waterproofing Inc.; CCW WIP 300HT.
 - b. Grace Construction Products, a unit of W. R. Grace & Co.; Ultra.
 - c. Henry Company; Blueskin PE200 HT.
 - d. Metal-Fab Manufacturing, LLC; MetShield.
 - e. Owens Corning; WeatherLock Metal High Temperature Underlayment.
- C. Slip Sheet: Building paper, 3-lb/100 sq. ft. minimum, rosin sized.

2.3 MISCELLANEOUS MATERIALS

- A. General: Provide materials and types of fasteners, solder, welding rods, protective coatings, separators, sealants, and other miscellaneous items as required for complete sheet metal flashing and trim installation and recommended by manufacturer of primary sheet metal or manufactured item unless otherwise indicated.
- B. Fasteners: Wood screws, annular threaded nails, self-tapping screws, self-locking rivets and bolts, and other suitable fasteners designed to withstand design loads and recommended by manufacturer of primary sheet metal or manufactured item.
1. General: Blind fasteners or self-drilling screws, gasketed, with hex-washer head.
 - a. Blind Fasteners: High-strength aluminum or stainless-steel rivets suitable for metal being fastened.
 - b. Spikes and Ferrules: Same material as gutter; with spike with ferrule matching internal gutter width.
 2. Fasteners for Zinc-Tin Alloy-Coated Copper Sheet: Copper, hardware bronze or Series 300 stainless steel.
 3. Fasteners for Aluminum Sheet: Aluminum or Series 300 stainless steel.
 4. Fasteners for Stainless-Steel Sheet: Series 300 stainless steel.
- C. Solder:

Weedsport Addition to Maintenance Section and Roof Replacement, MP 304.2

1. For Stainless Steel: ASTM B 32, Grade Sn60, with an acid flux of type recommended by stainless-steel sheet manufacturer.
 2. For Copper: ASTM B 32, 100 percent tin with a maximum lead content of 0.2 percent.
- D. Sealant Tape: Pressure-sensitive, 100 percent solids, gray polyisobutylene compound sealant tape with release-paper backing. Provide permanently elastic, non-sag, nontoxic, non-staining tape 1/2 inch wide and 1/8 inch thick.
- E. Elastomeric Sealant: ASTM C 920, elastomeric silicone polymer sealant; low modulus; of type, grade, class, and use classifications required to seal joints in sheet metal flashing and trim and remain watertight.
- F. Epoxy Seam Sealer: Two-part, noncorrosive, aluminum seam-cementing compound, recommended by aluminum manufacturer for exterior nonmoving joints, including riveted joints.
- G. Bituminous Coating: Cold-applied asphalt emulsion complying with ASTM D 1187.
- H. Asphalt Roofing Cement: ASTM D 4586, asbestos free, of consistency required for application.

2.4 MANUFACTURED SHEET METAL FLASHING AND TRIM

- A. Reglets: Units of type, material, and profile indicated, formed to provide secure interlocking of separate reglet and counterflashing pieces, and compatible with flashing indicated with factory-mitered and -welded corners and junctions.
1. Basis-of-Design Product: Subject to compliance with requirements, provide Fry Reglet Corporation; **Springlock Flashing System** or a comparable product by one of the following:
 - a. Cheney Flashing Company.
 - b. Heckmann Building Products, Inc.
 - c. Metal-Era, Inc.
- B. Reglets: Manufactured units formed to provide secure interlocking of separate reglet and counterflashing pieces, from the following exposed metal:
1. Formed Aluminum: 0.040 inch thick.
 2. Corners: Factory mitered and mechanically clinched and sealed watertight.
 3. Surface-Mounted Type: Provide reglets with slotted holes for fastening to substrate, with neoprene or other suitable weatherproofing washers, and with channel for sealant at top edge. For use only where masonry type reglet is not suitable.
 4. Masonry Type, Embedded: Provide reglets with offset top flange for embedment in masonry mortar joint.
- C. Counterflashings: Manufactured units of heights to overlap top edges of base flashings by 4 inches and in lengths not exceeding 12 feet designed to snap into reglets and compress against base flashings with joints lapped, from the following exposed metal:
1. Formed Aluminum: 0.040 inch thick.
- D. Aluminum Finish: Manufacturer's standard polyester paint finish, gray.

2.5 FABRICATION, GENERAL

- A. General: Custom fabricate sheet metal flashing and trim to comply with recommendations in SMACNA's "Architectural Sheet Metal Manual" that apply to design, dimensions, geometry, metal thickness, and other characteristics of item indicated. Fabricate items at the shop to greatest extent possible.
1. Fabricate sheet metal flashing and trim in thickness or weight needed to comply with performance requirements, but not less than that specified for each application and metal.

Weedsport Addition to Maintenance Section and Roof Replacement, MP 304.2

2. Obtain field measurements for accurate fit before shop fabrication.
 3. Form sheet metal flashing and trim without excessive oil canning, buckling, and tool marks and true to line and levels indicated, with exposed edges folded back to form hems.
 4. Conceal fasteners and expansion provisions where possible. Exposed fasteners are not allowed on faces exposed to view.
- B. Fabrication Tolerances: Fabricate sheet metal flashing and trim that is capable of installation to a tolerance of 1/4 inch in 20 feet on slope and location lines as indicated and within 1/8-inch offset of adjoining faces and of alignment of matching profiles.
- C. Sealed Joints: Form non-expansion but movable joints in metal to accommodate elastomeric sealant.
- D. Fabricate cleats and attachment devices from same material as accessory being anchored or from compatible, noncorrosive metal.
- E. Fabricate cleats and attachment devices of sizes as recommended by SMACNA's "Architectural Sheet Metal Manual" and by FMG Loss Prevention Data Sheet 1-49 for application, but not less than thickness of metal being secured.
- F. Seams: Fabricate nonmoving seams with flat-lock seams. Tin edges to be seamed, form seams, and solder.
- G. Seams for Aluminum: Fabricate nonmoving seams with flat-lock seams. Form seams and seal with epoxy seam sealer. Rivet joints where necessary for strength.
- H. Do not use graphite pencils to mark metal surfaces.

PART 3 - EXECUTION

3.1 EXAMINATION

- A. Examine substrates, areas, and conditions, with Installer present, to verify actual locations, dimensions and other conditions affecting performance of the Work.
1. Verify that substrate is sound, dry, smooth, clean, sloped for drainage, and securely anchored.
- B. Proceed with installation only after unsatisfactory conditions have been corrected.

3.2 UNDERLAYMENT INSTALLATION

- A. Felt Underlayment: Install felt underlayment with adhesive for temporary anchorage to minimize use of mechanical fasteners under sheet metal flashing and trim. Apply in shingle fashion to shed water, with lapped joints of not less than 2 inches.
- B. Self-Adhering Sheet Underlayment: Install self-adhering sheet underlayment, wrinkle free. Apply primer if required by underlayment manufacturer. Comply with temperature restrictions of underlayment manufacturer for installation; use primer rather than nails for installing underlayment at low temperatures. Apply in shingle fashion to shed water, with end laps of not less than 6 inches staggered 24 inches between courses. Overlap side edges not less than 3-1/2 inches. Roll laps with roller. Cover underlayment within 14 days.

3.3 INSTALLATION, GENERAL

- A. General: Anchor sheet metal flashing and trim and other components of the Work securely in place, with provisions for thermal and structural movement. Use fasteners, solder, welding rods, protective coatings, separators, sealants, and other miscellaneous items as required to complete sheet metal flashing and trim system.
1. Install sheet metal flashing and trim true to line and levels indicated. Provide uniform, neat seams with minimum exposure of solder, welds, and sealant.
 2. Install sheet metal flashing and trim to fit substrates and to result in watertight performance. Verify shapes and dimensions of surfaces to be covered before fabricating sheet metal.
 3. Space cleats not more than 12 inches apart. Anchor each cleat with two fasteners. Bend tabs over fasteners.
 4. Install exposed sheet metal flashing and trim without excessive oil canning, buckling, and tool marks.
 5. Install sealant tape where indicated.
 6. Torch cutting of sheet metal flashing and trim is not permitted.
 7. Do not use graphite pencils to mark aluminum surfaces.
- B. Metal Protection: Where dissimilar metals will contact each other or corrosive substrates, protect against galvanic action by painting contact surfaces with bituminous coating or by other permanent separation as recommended by SMACNA.
1. Coat back side of uncoated aluminum and stainless-steel sheet metal flashing and trim with bituminous coating where flashing and trim will contact wood, ferrous metal, or cementitious construction.
 2. Underlayment: Where installing metal flashing directly on cementitious or wood substrates, install a course of felt underlayment and cover with a slip sheet.
- C. Expansion Provisions: Provide for thermal expansion of exposed flashing and trim. Space movement joints at a maximum of 10 feet with no joints allowed within 24 inches of corner or intersection.
- D. Fastener Sizes: Use fasteners of sizes as follows:
1. Penetrate wood sheathing not less than 1-1/4 inches for nails and not less than 3/4 inch for wood screws
 2. Penetrate metal decking not less than recommended by fastener manufacturer to achieve maximum pull-out resistance.
- E. Seal joints as shown and as required for watertight construction.
1. Where sealant-filled joints are used, embed hooked flanges of joint members not less than 1 inch into sealant. Form joints to completely conceal sealant. When ambient temperature at time of installation is moderate, between 40 and 70 deg F, set joint members for 50 percent movement each way. Adjust setting proportionately for installation at higher ambient temperatures. Do not install sealant-type joints at temperatures below 40 deg F.
 2. Prepare joints and apply sealants to comply with requirements in Division 07 Section "Joint Sealants."
- F. Soldered Joints: Clean surfaces to be soldered, removing oils and foreign matter. Pre-tin edges of sheets to be soldered to a width of 1-1/2 inches, except reduce pre-tinning where pre-tinned surface would show in completed Work.
1. Do not solder metallic-coated steel and aluminum sheet.
 2. Pre-tinning is not required for zinc-tin alloy-coated copper.

Weedsport Addition to Maintenance Section and Roof Replacement, MP 304.2

3. Do not use torches for soldering. Heat surfaces to receive solder and flow solder into joint. Fill joint completely. Completely remove flux and spatter from exposed surfaces.
4. Stainless-Steel Soldering: Tin edges of uncoated sheets using solder recommended for stainless steel and acid flux. Promptly remove acid flux residue from metal after tinning and soldering. Comply with solder manufacturer's recommended methods for cleaning and neutralization.

G. Rivets: Rivet joints in uncoated aluminum where indicated and where necessary for strength.

3.4 ROOF FLASHING INSTALLATION

- A. General: Install sheet metal flashing and trim to comply with performance requirements and SMACNA's "Architectural Sheet Metal Manual." Provide concealed fasteners where possible, set units true to line, and level as indicated. Install work with laps, joints, and seams that will be permanently watertight and weather resistant.
- B. Pipe or Post Counterflashing: Install counterflashing umbrella with close-fitting collar with top edge flared for elastomeric sealant, extending a minimum of 4 inches over base flashing. Install stainless-steel draw band and tighten.
- C. Counterflashing: Coordinate installation of counterflashing with installation of base flashing. Insert counterflashing in reglets or receivers and fit tightly to base flashing. Extend counterflashing 4 inches over base flashing. Lap counterflashing joints a minimum of 4 inches and bed with sealant. Secure in a waterproof manner by means of snap-in installation and sealant or lead wedges and sealant.
- D. Roof-Penetration Flashing: Coordinate installation of roof-penetration flashing with installation of roofing and other items penetrating roof. Seal with elastomeric sealant and clamp flashing to pipes that penetrate roof.

3.5 WALL FLASHING INSTALLATION

- A. General: Install sheet metal wall flashing to intercept and exclude penetrating moisture according to SMACNA recommendations and as indicated. Coordinate installation of wall flashing with installation of wall-opening components such as windows, doors, and louvers.
- B. Through-Wall Flashing: Installation of through-wall flashing is specified in Division 04 Section "Unit Masonry."
- C. Reglets: Installation of reglets is specified in Division 04 Section "Unit Masonry."
- D. Opening Flashings in Frame Construction: Install continuous head, sill, and similar flashings to extend 4 inches beyond wall openings.

3.6 MISCELLANEOUS FLASHING INSTALLATION

- A. Equipment Support Flashing: Coordinate installation of equipment support flashing with installation of roofing and equipment. Weld or seal flashing with elastomeric sealant to equipment support member.

3.7 ERECTION TOLERANCES

- A. Installation Tolerances: Shim and align sheet metal flashing and trim within installed tolerance of 1/4 inch in 20 feet on slope and location lines as indicated and within 1/8-inch offset of adjoining faces and of alignment of matching profiles.

Weedsport Addition to Maintenance Section and Roof Replacement, MP 304.2

3.8 CLEANING AND PROTECTION

- A. Clean exposed metal surfaces of substances that interfere with uniform oxidation and weathering.
- B. Clean and neutralize flux materials. Clean off excess solder.
- C. Clean off excess sealants.
- D. Remove temporary protective coverings and strippable films as sheet metal flashing and trim are installed unless otherwise indicated in manufacturer's written installation instructions. On completion of installation, remove unused materials and clean finished surfaces. Maintain in a clean condition during construction.
- E. Replace sheet metal flashing and trim that have been damaged or that have deteriorated beyond successful repair by finish touchup or similar minor repair procedures.

END OF SECTION 076200

SECTION 077100 - ROOF SPECIALTIES

PART 1 - GENERAL

1.1 SUMMARY

- A. Section Includes:
1. Roof-edge flashings.
 2. Pre-manufactured aluminum roof ladders.

1.2 PERFORMANCE REQUIREMENTS

- A. General Performance: Roof specialties shall withstand exposure to weather and resist thermally induced movement without failure, rattling, leaking, or fastener disengagement due to defective manufacture, fabrication, installation, or other defects in construction.
- B. FM Approvals' Listing: Manufacture and install roof-edge flashings that are listed in FM Approvals' "RoofNav" and approved for windstorm classification, Class 1-90. Identify materials with FM Approvals' markings.
- C. SPRI Wind Design Standard: Manufacture and install roof-edge flashings tested according to SPRI ES-1 and capable of resisting the following design pressures:
1. Design Pressure: As indicated on Drawings.
- D. Thermal Movements: Allow for thermal movements from ambient and surface temperature changes to prevent buckling, opening of joints, hole elongation, overstressing of components, failure of joint sealants, failure of connections, and other detrimental effects. Provide clips that resist rotation and avoid shear stress as a result of thermal movements. Base calculations on surface temperatures of materials due to both solar heat gain and nighttime-sky heat loss.
1. Temperature Change (Range): 120 deg F, ambient; 180 deg F, material surfaces.

1.3 SUBMITTALS

- A. Product Data: For each type of product indicated. Include construction details, material descriptions, dimensions of individual components and profiles, and finishes.
- B. Samples for Initial Selection: For each type of roof specialty indicated with factory-applied color finishes.
- C. Product Test Reports: Based on evaluation of comprehensive tests performed by a qualified testing agency, for roof-edge flashings.
- D. Maintenance Data: For roofing specialties to include in maintenance manuals.
- E. Warranty: Sample of special warranty.

1.4 QUALITY ASSURANCE

- A. Preinstallation Conference: Conduct conference at Project site.
1. Meet with Owner, Architect, Owner's insurer if applicable, Installer, and installers whose work interfaces with or affects roof specialties including installers of roofing materials and accessories.
 2. Examine substrate conditions for compliance with requirements, including flatness and attachment to structural members.

Weedsport Addition to Maintenance Section and Roof Replacement, MP 304.2

3. Review special roof details, roof drainage, and condition of other construction that will affect roof specialties.

1.5 DELIVERY, STORAGE, AND HANDLING

- A. Do not store roof specialties in contact with other materials that might cause staining, denting, or other surface damage. Store roof specialties away from uncured concrete and masonry.
- B. Protect strippable protective covering on roof specialties from exposure to sunlight and high humidity, except to extent necessary for the period of roof specialties installation.

1.6 WARRANTY

- A. Special Warranty on Painted Finishes: Manufacturer's standard form in which manufacturer agrees to repair finish or replace roof specialties that show evidence of deterioration of factory-applied finishes within specified warranty period.
 1. Fluoropolymer Finish: Deterioration includes, but is not limited to, the following:
 - a. Color fading more than 5 Hunter units when tested according to ASTM D 2244.
 - b. Chalking in excess of a No. 8 rating when tested according to ASTM D 4214.
 - c. Cracking, checking, peeling, or failure of paint to adhere to bare metal.
 2. Finish Warranty Period: 20 years from date of Substantial Completion.

PART 2 - PRODUCTS**2.1 ROOF-EDGE FLASHINGS**

- A. Roof-Edge Fascia: Manufactured, two-piece, roof-edge fascia consisting of snap-on metal fascia cover in section lengths not exceeding 12 feet and a continuous formed galvanized-steel sheet cant, 0.028 inch thick, minimum, with extended vertical leg terminating in a drip-edge cleat. Provide matching corner units.
 1. Basis-of-Design Product: Subject to compliance with requirements, provide Tremco **TremLock™ Fascia** or a comparable product by one of the following:
 - a. Hickman Company, W. P.
 - b. Metal-Era, Inc.
 2. Products must qualify to be included under the Tremco full system warranty
 3. Fascia Cover: Fabricated from the following exposed metal:
 - a. Kynar/Hylar coated aluminum, 0.050 thickness.
 4. Corners: Factory mitered and mechanically clinched and sealed watertight.
 5. Splice Plates: Concealed, of same material, finish, and shape as fascia cover.
 6. Face dimensions as indicated on drawings.
 7. Two coat Kynar 500/Hylar 5000 color to be selected from manufacturer's standard color chart.

2.2 UNDERLAYMENT MATERIALS

- A. Self-Adhering, High-Temperature Sheet: Minimum 30 to 40 mils thick, consisting of slip-resisting polyethylene-film top surface laminated to layer of butyl or SBS-modified asphalt adhesive, with release-paper backing; cold applied. Provide primer when recommended by underlayment manufacturer.

Weedsport Addition to Maintenance Section and Roof Replacement, MP 304.2

2.3 ALUMINUM LADDERS

- A. Low parapet access ladder: Manufactured, tubular rail aluminum access ladder with platform.
- B. Basis-of-Design Product: Subject to compliance with requirements, provide O’Keeffe’s aluminum ladder with platform, Model 503A or a comparable product by one of the following:
 - 1. Precision Ladders, LLC
 - 2. Alaco Ladder Company
 - 3. Jomy
- C. Rails and rungs: extruded aluminum.
- D. Top platform: 1” x 3” x 1/8” minimum channel frame with 1 ¼” minimum grate platform surface.
- E. Supports: 3/16” minimum aluminum wall brackets – ladder primary support must be by wall brackets.
- F. Finish: Powder coat selected from manufacturer’s standard color chart (OSHA safety colors).

2.4 MISCELLANEOUS MATERIALS

- A. General: Provide materials and types of fasteners, protective coatings, sealants, and other miscellaneous items required by manufacturer for a complete installation.
- B. Fasteners: Manufacturer's recommended fasteners, suitable for application and designed to meet performance requirements. Furnish the following unless otherwise indicated:
 - 1. Exposed Penetrating Fasteners: Gasketed screws with hex washer heads matching color of sheet metal.
 - 2. Fasteners for Zinc-Coated (Galvanized) Steel Sheet: Series 300 stainless steel or hot-dip zinc-coated steel according to ASTM A 153 or ASTM F 2329.
- C. Elastomeric Sealant: ASTM C 920, elastomeric silicone polymer sealant of type, grade, class, and use classifications required by roofing-specialty manufacturer for each application.
- D. Bituminous Coating: Cold-applied asphalt emulsion complying with ASTM D 1187.

2.5 GENERAL FINISH REQUIREMENTS

- A. Comply with NAAMM's "Metal Finishes Manual for Architectural and Metal Products" for recommendations for applying and designating finishes.
- B. Protect mechanical and painted finishes on exposed surfaces from damage by applying a strippable, temporary protective covering before shipping.
- C. Appearance of Finished Work: Noticeable variations in same piece are not acceptable. Variations in appearance of adjoining components are acceptable if they are within the range of approved Samples and are assembled or installed to minimize contrast.

PART 3 - EXECUTION**3.1 EXAMINATION**

- A. Examine substrates, areas, and conditions, with Installer present, to verify actual locations, dimensions, and other conditions affecting performance of the Work.
- B. Examine walls, roof edges, and parapets for suitable conditions for roof specialties.

Weedsport Addition to Maintenance Section and Roof Replacement, MP 304.2

- C. Verify that substrate is sound, dry, smooth, clean, sloped for drainage, and securely anchored.
- D. Proceed with installation only after unsatisfactory conditions have been corrected.

3.2 UNDERLAYMENT INSTALLATION

- A. Self-Adhering Sheet Underlayment: Install wrinkle free. Apply primer if required by underlayment manufacturer. Comply with temperature restrictions of underlayment manufacturer for installation; use primer rather than nails for installing underlayment at low temperatures. Apply in shingle fashion to shed water. Overlap edges not less than 3-1/2 inches. Roll laps with roller. Cover underlayment within 14 days.

3.3 INSTALLATION, GENERAL

- A. General: Install roof specialties according to manufacturer's written instructions. Anchor roof specialties securely in place, with provisions for thermal and structural movement. Use fasteners, solder, protective coatings, separators, sealants, and other miscellaneous items as required to complete roof-specialty systems.
 1. Install roof specialties level, plumb, true to line and elevation; with limited oil-canning and without warping, jogs in alignment, buckling, or tool marks.
 2. Provide uniform, neat seams with minimum exposure of solder and sealant.
 3. Install roof specialties to fit substrates and to result in watertight performance. Verify shapes and dimensions of surfaces to be covered before manufacture.
 4. Torch cutting of roof specialties is not permitted.
 5. Do not use graphite pencils to mark aluminum surfaces.
- B. Metal Protection: Protect metals against galvanic action by separating dissimilar metals from contact with each other or with corrosive substrates by painting contact surfaces with bituminous coating or by other permanent separation as recommended by manufacturer.
 1. Underlayment: Where installing metal flashing directly on cementitious or wood substrates, install a course of self-adhering, high-temperature sheet underlayment.
- C. Expansion Provisions: Allow for thermal expansion of exposed roof specialties.
 1. Space movement joints at a maximum of 12 feet with no joints within 18 inches of corners or intersections unless otherwise shown on Drawings.
 2. When ambient temperature at time of installation is between 40 and 70 deg F, set joint members for 50 percent movement each way. Adjust setting proportionately for installation at higher ambient temperatures.
- D. Fastener Sizes: Use fasteners of sizes as follows:
 1. Penetrate wood blocking or sheathing not less than 1-1/4 inches for nails and not less than 3/4 inch for wood screws.
 2. Penetrate substrate not less than recommended by fastener manufacturer to achieve maximum pull-out resistance.
- E. Seal joints with elastomeric sealant as required by roofing-specialty manufacturer.
- F. Seal joints as required for watertight construction. Place sealant to be completely concealed in joint. Do not install sealants at temperatures below 40 deg F.

3.4 ROOF-EDGE FLASHING INSTALLATION

- A. Install cleats, cants, and other anchoring and attachment accessories and devices with concealed fasteners.

Weedsport Addition to Maintenance Section and Roof Replacement, MP 304.2

- B. Anchor roof edgings with manufacturer's required devices, fasteners, and fastener spacing to meet performance requirements.

3.5 LADDER INSTALLATION

- A. Install ladders in configurations and at locations indicated on Drawings. Provide clearances from building elements as recommended by the manufacturer, and complying with OSHA standards.
- B. Prior to installation verify that the substrates are structurally sound, solid, clean, and ready to accept required fasteners.
- C. Use Manufacturer-supplied brackets and fasteners as recommended by the ladder Manufacturer.

3.6 CLEANING AND PROTECTION

- A. On completion of installation, clean finished surfaces including removing unused fasteners, metal filings, pop rivet stems, and pieces of flashing. Maintain roof specialties in a clean condition during construction.
- B. Replace roof specialties that have been damaged or that cannot be successfully repaired by finish touchup or similar minor repair procedures.

END OF SECTION 077100

SECTION 079200 - JOINT SEALANTS

PART 1 - GENERAL

1.1 SUMMARY

A. Section Includes:

1. Silicone joint sealants.
2. Nonstaining silicone joint sealants.
3. Mildew-resistant joint sealants.
4. Urethane joint sealants.
5. Latex joint sealants.

1.2 ACTION SUBMITTALS

- A. Product Data: For each joint-sealant product.
- B. Samples for Initial Selection: Manufacturer's color charts consisting of strips of cured sealants showing the full range of colors available for each product exposed to view.
- C. Joint-Sealant Schedule: Include the following information:
 1. Joint-sealant application, joint location, and designation.
 2. Joint-sealant manufacturer and product name.
 3. Joint-sealant formulation.
 4. Joint-sealant color.

1.3 INFORMATIONAL SUBMITTALS

- A. Qualification Data: For qualified testing agency.
- B. Product Test Reports: For each kind of joint sealant, for tests performed by a qualified testing agency.
- C. Field-Adhesion-Test Reports: For each sealant application tested.
- D. Sample Warranties: For special warranties.

1.4 QUALITY ASSURANCE

- A. Installer Qualifications: An authorized representative who is trained and approved by manufacturer.
- B. Product Testing: Test joint sealants using a qualified testing agency.
 1. Testing Agency Qualifications: Qualified according to ASTM C 1021 to conduct the testing indicated.

1.5 FIELD CONDITIONS

- A. Do not proceed with installation of joint sealants under the following conditions:
 1. When ambient and substrate temperature conditions are outside limits permitted by joint-sealant manufacturer.

Weedsport Addition to Maintenance Section and Roof Replacement, MP 304.2

2. When joint substrates are wet.
3. Where joint widths are less than those allowed by joint-sealant manufacturer for applications indicated.
4. Where contaminants capable of interfering with adhesion have not yet been removed from joint substrates.

1.6 WARRANTY

- A. Special Installer's Warranty: Installer agrees to repair or replace joint sealants that do not comply with performance and other requirements specified in this Section within specified warranty period.
 1. Warranty Period: Two years from date of Substantial Completion.
- B. Special Manufacturer's Warranty for Silicone Sealants: Manufacturer agrees to furnish joint sealants to repair or replace those joint sealants that do not comply with performance and other requirements specified in this Section within specified warranty period.
 1. Warranty Period: Twenty years from date of Substantial Completion.
- C. Special warranties specified in this article exclude deterioration or failure of joint sealants from the following:
 1. Movement of the structure caused by stresses on the sealant exceeding sealant manufacturer's written specifications for sealant elongation and compression.
 2. Disintegration of joint substrates from causes exceeding design specifications.
 3. Mechanical damage caused by individuals, tools, or other outside agents.
 4. Changes in sealant appearance caused by accumulation of dirt or other atmospheric contaminants.

PART 2 - PRODUCTS**2.1 JOINT SEALANTS, GENERAL**

- A. Compatibility: Provide joint sealants, backings, and other related materials that are compatible with one another and with joint substrates under conditions of service and application, as demonstrated by joint-sealant manufacturer, based on testing and field experience.
- B. Colors of Exposed Joint Sealants: As selected by Architect from manufacturer's full range.

2.2 SILICONE JOINT SEALANTS

- A. Silicone, S, NS, 50, NT: Single-component, nonsag, plus 50 percent and minus 50 percent movement capability, nontraffic-use, neutral-curing silicone joint sealant; ASTM C 920, Type S, Grade NS, Class 50, Use NT.
 1. Products: Subject to compliance with requirements, available products that may be incorporated into the Work include, but are not limited to the following:
 - a. Dow Corning Corporation; DOW CORNING® 795 SILICONE BUILDING SEALANT.

Weedsport Addition to Maintenance Section and Roof Replacement, MP 304.2

2.3 NONSTAINING SILICONE JOINT SEALANTS

- A. Nonstaining Joint Sealants: No staining of substrates when tested according to ASTM C 1248.
- B. Silicone, Nonstaining, S, NS, 100/50, T, NT: Nonstaining, single-component, nonsag, plus 100 percent and minus 50 percent movement capability, traffic- and nontraffic-use, neutral-curing silicone joint sealant; ASTM C 920, Type S, Grade NS, Class 100/50, Uses T and NT.
 - 1. Products: Subject to compliance with requirements, available products that may be incorporated into the Work include, but are not limited to the following:
 - a. Dow Corning Corporation; DOW CORNING® 790 SILICONE BUILDING SEALANT

2.4 URETHANE JOINT SEALANTS

- A. Urethane, S, NS, 100/50, T, NT: Single-component, nonsag, plus 100 percent and minus 50 percent movement capability, traffic- and nontraffic-use, urethane joint sealant; ASTM C 920, Type S, Grade NS, Class 100/50, Uses T and NT.
 - 1. Products: Subject to compliance with requirements, available products that may be incorporated into the Work include, but are not limited to the following:
 - a. Sika Corporation; Joint Sealants; Sikaflex 15LM.

2.5 MILDEW-RESISTANT JOINT SEALANTS

- A. Mildew-Resistant Joint Sealants: Formulated for prolonged exposure to humidity with fungicide to prevent mold and mildew growth.
- B. Silicone, Mildew Resistant, Acid Curing, S, NS, 25, NT: Mildew-resistant, single-component, nonsag, plus 25 percent and minus 25 percent movement capability, nontraffic-use, acid-curing silicone joint sealant; ASTM C 920, Type S, Grade NS, Class 25, Use NT.
 - 1. Products: Subject to compliance with requirements, available products that may be incorporated into the Work include, but are not limited to, the following:
 - a. Dow Corning Corporation; 786 Silicone Sealant
 - b. GE Construction Sealants; Momentive Performance Materials Inc.; SCS 1700.
 - c. Tremco Incorporated; Tremsil 200.

2.6 LATEX JOINT SEALANTS

- A. Acrylic Latex: Acrylic latex or siliconized acrylic latex, ASTM C 834, Type OP, Grade NF.
 - 1. Products: Subject to compliance with requirements, available products that may be incorporated into the Work include, but are not limited to the following:
 - a. Pecora Corporation; AC-20.
 - b. Tremco Incorporated; Tremflex 834.

2.7 JOINT-SEALANT BACKING

- A. Sealant Backing Material, General: Nonstaining; compatible with joint substrates, sealants, primers, and other joint fillers; and approved for applications indicated by sealant manufacturer based on field experience and laboratory testing.

Weedsport Addition to Maintenance Section and Roof Replacement, MP 304.2

- B. Cylindrical Sealant Backings: ASTM C 1330, Type C (closed-cell material with a surface skin), and of size and density to control sealant depth and otherwise contribute to producing optimum sealant performance.
- C. Bond-Breaker Tape: Polyethylene tape or other plastic tape recommended by sealant manufacturer for preventing sealant from adhering to rigid, inflexible joint-filler materials or joint surfaces at back of joint. Provide self-adhesive tape where applicable.

2.8 MISCELLANEOUS MATERIALS

- A. Primer: Material recommended by joint-sealant manufacturer where required for adhesion of sealant to joint substrates indicated, as determined from preconstruction joint-sealant-substrate tests and field tests.
- B. Cleaners for Nonporous Surfaces: Chemical cleaners acceptable to manufacturers of sealants and sealant backing materials, free of oily residues or other substances capable of staining or harming joint substrates and adjacent nonporous surfaces in any way, and formulated to promote optimum adhesion of sealants to joint substrates.
- C. Masking Tape: Nonstaining, nonabsorbent material compatible with joint sealants and surfaces adjacent to joints.

PART 3 - EXECUTION**3.1 EXAMINATION**

- A. Examine joints indicated to receive joint sealants, with Installer present, for compliance with requirements for joint configuration, installation tolerances, and other conditions affecting performance of the Work.
- B. Proceed with installation only after unsatisfactory conditions have been corrected.

3.2 PREPARATION

- A. Surface Cleaning of Joints: Clean out joints immediately before installing joint sealants to comply with joint-sealant manufacturer's written instructions and the following requirements:
 1. Remove all foreign material from joint substrates that could interfere with adhesion of joint sealant, including dust, paints (except for permanent, protective coatings tested and approved for sealant adhesion and compatibility by sealant manufacturer), old joint sealants, oil, grease, waterproofing, water repellents, water, surface dirt, and frost.
 2. Clean porous joint substrate surfaces by brushing, grinding, mechanical abrading, or a combination of these methods to produce a clean, sound substrate capable of developing optimum bond with joint sealants. Remove loose particles remaining after cleaning operations above by vacuuming or blowing out joints with oil-free compressed air. Porous joint substrates include the following:
 - a. Concrete.
 - b. Masonry.
 - c. Unglazed surfaces of ceramic tile.
 - d. Exterior insulation and finish systems.
 3. Remove laitance and form-release agents from concrete.

Weedsport Addition to Maintenance Section and Roof Replacement, MP 304.2

4. Clean nonporous joint substrate surfaces with chemical cleaners or other means that do not stain, harm substrates, or leave residues capable of interfering with adhesion of joint sealants. Nonporous joint substrates include the following:
 - a. Metal.
 - b. Glass.
 - c. Porcelain enamel.
 - d. Glazed surfaces of ceramic tile.
- B. Joint Priming: Prime joint substrates where recommended by joint-sealant manufacturer or as indicated by preconstruction joint-sealant-substrate tests or prior experience. Apply primer to comply with joint-sealant manufacturer's written instructions. Confine primers to areas of joint-sealant bond; do not allow spillage or migration onto adjoining surfaces.
- C. Masking Tape: Use masking tape where required to prevent contact of sealant or primer with adjoining surfaces that otherwise would be permanently stained or damaged by such contact or by cleaning methods required to remove sealant smears. Remove tape immediately after tooling without disturbing joint seal.

3.3 INSTALLATION OF JOINT SEALANTS

- A. General: Comply with joint-sealant manufacturer's written installation instructions for products and applications indicated, unless more stringent requirements apply.
- B. Sealant Installation Standard: Comply with recommendations in ASTM C 1193 for use of joint sealants as applicable to materials, applications, and conditions indicated.
- C. Install sealant backings of kind indicated to support sealants during application and at position required to produce cross-sectional shapes and depths of installed sealants relative to joint widths that allow optimum sealant movement capability.
 1. Do not leave gaps between ends of sealant backings.
 2. Do not stretch, twist, puncture, or tear sealant backings.
 3. Remove absorbent sealant backings that have become wet before sealant application, and replace them with dry materials.
- D. Install bond-breaker tape behind sealants where sealant backings are not used between sealants and backs of joints.
- E. Install sealants using proven techniques that comply with the following and at the same time backings are installed:
 1. Place sealants so they directly contact and fully wet joint substrates.
 2. Completely fill recesses in each joint configuration.
 3. Produce uniform, cross-sectional shapes and depths relative to joint widths that allow optimum sealant movement capability.
- F. Tooling of Nonsag Sealants: Immediately after sealant application and before skinning or curing begins, tool sealants according to requirements specified in subparagraphs below to form smooth, uniform beads of configuration indicated; to eliminate air pockets; and to ensure contact and adhesion of sealant with sides of joint.
 1. Remove excess sealant from surfaces adjacent to joints.
 2. Use tooling agents that are approved in writing by sealant manufacturer and that do not discolor sealants or adjacent surfaces.

Weedsport Addition to Maintenance Section and Roof Replacement, MP 304.2

3. Provide concave joint profile per Figure 8A in ASTM C 1193 unless otherwise indicated.
 - a. Use masking tape to protect surfaces adjacent to recessed tooled joints.

3.4 FIELD QUALITY CONTROL

A. Field-Adhesion Testing: Field test joint-sealant adhesion to joint substrates as follows:

1. Extent of Testing: Test completed and cured sealant joints as follows:
 - a. Perform 5 tests for the first 1000 feet (300 m) of joint length for each kind of sealant and joint substrate.
 - b. Perform one test for each 1000 feet (300 m) of joint length thereafter or one test per each floor per elevation.
2. Test Method: Test joint sealants according to Method A, Field-Applied Sealant Joint Hand Pull Tab, in Appendix X1 in ASTM C 1193 or Method A, Tail Procedure, in ASTM C 1521.
 - a. For joints with dissimilar substrates, verify adhesion to each substrate separately; extend cut along one side, verifying adhesion to opposite side. Repeat procedure for opposite side.
3. Inspect tested joints and report on the following:
 - a. Whether sealants filled joint cavities and are free of voids.
 - b. Whether sealant dimensions and configurations comply with specified requirements.
 - c. Whether sealants in joints connected to pulled-out portion failed to adhere to joint substrates or tore cohesively. Include data on pull distance used to test each kind of product and joint substrate. Compare these results to determine if adhesion complies with sealant manufacturer's field-adhesion hand-pull test criteria.
4. Record test results in a field-adhesion-test log. Include dates when sealants were installed, names of persons who installed sealants, test dates, test locations, whether joints were primed, adhesion results and percent elongations, sealant material, sealant configuration, and sealant dimensions.
5. Repair sealants pulled from test area by applying new sealants following same procedures used originally to seal joints. Ensure that original sealant surfaces are clean and that new sealant contacts original sealant.

- #### B. Evaluation of Field-Adhesion-Test Results: Sealants not evidencing adhesive failure from testing or noncompliance with other indicated requirements will be considered satisfactory. Remove sealants that fail to adhere to joint substrates during testing or to comply with other requirements. Retest failed applications until test results prove sealants comply with indicated requirements.

3.5 CLEANING

- #### A. Clean off excess sealant or sealant smears adjacent to joints as the Work progresses by methods and with cleaning materials approved in writing by manufacturers of joint sealants and of products in which joints occur.

Weedsport Addition to Maintenance Section and Roof Replacement, MP 304.2

3.6 PROTECTION

- A. Protect joint sealants during and after curing period from contact with contaminating substances and from damage resulting from construction operations or other causes so sealants are without deterioration or damage at time of Substantial Completion. If, despite such protection, damage or deterioration occurs, cut out, remove, and repair damaged or deteriorated joint sealants immediately so installations with repaired areas are indistinguishable from original work.

3.7 JOINT-SEALANT SCHEDULE

- A. Joint-Sealant Application: Exterior joints in vertical surfaces and horizontal nontraffic surfaces.
1. Joint Locations:
 - a. Construction joints in cast-in-place concrete.
 - b. Joints between plant-precast architectural concrete units.
 - c. Control and expansion joints in unit masonry.
 - d. Joints in exterior insulation and finish systems.
 - e. Joints between different materials listed above.
 2. Joint Sealant: Silicone, nonstaining, S, NS, 100/50, T,NT.
 3. Joint-Sealant Color: As selected by Architect from manufacturer's full range of colors.
- B. Joint-Sealant Application: Exterior joints in vertical surfaces and horizontal nontraffic surfaces.
1. Joint Locations:
 - a. Joints between metal panels.
 - b. Joints between aluminum framing components.
 - c. Perimeter joints between building materials and frames of doors windows and louvers.
 2. Joint Sealant: Silicone, nonstaining, S, NS, 50, NT.
 3. Joint-Sealant Color: As selected by Architect from manufacturer's full range of colors.
- C. Joint-Sealant Application: Interior joints in vertical surfaces and horizontal nontraffic surfaces where painting is required
1. Joint Locations:
 - a. Control and expansion joints on exposed interior surfaces of exterior walls.
 - b. Perimeter joints between interior wall surfaces and frames of interior doors windows and elevator entrances.
 - c. Vertical joints on exposed surfaces of unit masonry concrete walls and partitions.
 2. Joint Sealant: Urethane, S, NS, 100/50, T, NT.
 3. Joint-Sealant Color: As selected by Architect from manufacturer's full range of colors.
- D. Joint-Sealant Application: Interior joints in vertical surfaces and horizontal nontraffic surfaces not subject to significant movement and scheduled for painting.
1. Joint Sealant: Acrylic latex.
 2. Joint-Sealant Color: As selected by Architect from manufacturer's full range of colors.

Weedsport Addition to Maintenance Section and Roof Replacement, MP 304.2

- E. Joint-Sealant Application: Mildew-resistant interior joints in vertical surfaces and horizontal nontraffic surfaces.
1. Joint Locations:
 - a. Joints between plumbing fixtures and adjoining walls, floors, and counters.
 - b. Tile control and expansion joints where indicated.
 - c. Countertops
 - d. Other joints as indicated on Drawings.
 2. Joint Sealant: Silicone, mildew resistant, acid curing, S, NS, 25, NT.
 3. Joint-Sealant Color: As selected by Architect from manufacturer's full range of colors.

END OF SECTION 079200

ITEM 627.0008 25**OPENINGS****1. DESCRIPTION:**

- 1.01 Furnish all labor, materials, equipment and services necessary to complete the work as indicated on the Contract Plans and the attached Specification Summary.
- 1.02 All work shall conform to the requirements specified in Part 1 – General, of the Sections listed.

2. MATERIALS:

- 2.01 The materials shall be as specified in Part 2 – Products, of the Sections listed.

3. CONSTRUCTION DETAILS:

- 3.01 The construction details shall be as specified on Part 3 – Execution, if the Sections listed.

4. METHOD OF MEASUREMENT:

- 4.01 This item shall be measured for payment on a lump sum basis for the work completed in accordance with the Contract Documents and as directed by the Engineer.

5. BASIS OF PAYMENT:

- 5.01 Payment for this item shall be made at the lump sum bid price bid. The lump sum price bid shall include cost of furnishing all labor, material, equipment and appliances necessary to complete the work as indicated on the Contract Plans and as specified herein in the Sections listed.
- 5.02 Detailed Estimate:
 - A. Before the first certificate of payment is issued for the work under this item, submit a detailed estimate of quantities and prices for all materials, labor, and other items included under this item, which shall aggregate the contract lump sum price bid for this item. Prepare the detailed estimate in the same sequence as the Sections listed.
 - B. The detailed estimate shall be supported by such evidence, including certified copies of subcontracts, as the Engineer may require.
 - C. The detailed estimate must be approved by the Engineer who may revise it as, in his/her reasonable judgment, is necessary to make the various item conform to their true values. The value of each certificate of payment will be based on the approved detailed estimate.
- 5.03 Monthly payments will be made for this item in proportion to the total amount of work completed.

ITEM 627.0008 25**OPENINGS****1. SPECIFICATION SUMMARY**

1.01 This Item includes the following specifications:

- A. Section 081113 HOLLOW METAL DOORS AND FRAMES
- B. Section 085113 ALUMINUM WINDOWS
- C. Section 087100 DOOR HARDWARE

1.02 This item shall include, but not be limited to, the following:

- A. New doors and windows and associated hardware for the addition to the existing building.

SECTION 081113 - HOLLOW METAL DOORS AND FRAMES

PART 1 - GENERAL

1.1 SUMMARY

- A. Section includes:
1. Interior standard steel doors and frames.
 2. Exterior standard steel doors and frames.

1.2 ACTION SUBMITTALS

- A. Product Data: For each type of product.
- B. Shop Drawings: Include the following:
1. Elevations of each door type.
 2. Details of doors, including vertical- and horizontal-edge details and metal thicknesses.
 3. Frame details for each frame type, including dimensioned profiles and metal thicknesses.
- C. Product Schedule: For hollow-metal doors and frames, prepared by or under the supervision of supplier, using same reference numbers for details and openings as those on Drawings. Coordinate with final door hardware schedule.

1.3 INFORMATIONAL SUBMITTALS

- A. Product test reports.
- B. Field quality control reports.

1.4 CLOSEOUT SUBMITTALS

- A. Record Documents: For fire-rated doors, list of door numbers and applicable room name and number to which door accesses.

PART 2 - PRODUCTS

2.1 MANUFACTURERS

- A. Manufacturers: Subject to compliance with requirements, provide products by one of the following:
1. Ceco Door; ASSA ABLOY.
 2. Curries Company; ASSA ABLOY.
 3. Pioneer Industries.
 4. Republic Doors and Frames.
 5. Steelcraft; an Allegion brand.

2.2 PERFORMANCE REQUIREMENTS

- A. Fire-Rated Door Assemblies: Assemblies complying with NFPA 80 that are listed and labeled by a qualified testing agency acceptable to authorities having jurisdiction for fire-protection ratings indicated on Drawings, based on testing at positive pressure according to NFPA 252 or UL 10C.
 - 1. Smoke- and Draft-Control Door Assemblies: Listed and labeled for smoke and draft control by a qualified testing agency acceptable to authorities having jurisdiction, based on testing according to UL 1784 and installed in compliance with NFPA 105.
- B. Thermally Rated Door Assemblies: Provide door assemblies with U-factor of not more than 0.50 deg Btu/F x h x sq. ft. (2.84 W/K x sq. m) when tested according to ASTM C518.

2.3 INTERIOR STANDARD STEEL DOORS AND FRAMES

- A. Construct hollow-metal doors and frames to comply with standards indicated for materials, fabrication, hardware locations, hardware reinforcement, tolerances, and clearances, and as specified.
- B. Heavy-Duty Doors and Frames: ANSI/SDI A250.8, Level 2; ANSI/SDI A250.4, Level B. At locations indicated in the Door and Frame Schedule.
 - 1. Doors:
 - a. Type: As indicated in the Door and Frame Schedule.
 - b. Thickness: 1-3/4 inches (44.5 mm).
 - c. Face: Metallic-coated steel sheet, minimum thickness of 0.042 inch (1.0 mm).
 - d. Edge Construction: Model 1, Full Flush.
 - e. Core: Manufacturer's standard.
 - f. Fire-Rated Core: Manufacturer's standard laminated mineral board core for fire-rated doors.
 - 2. Frames:
 - a. Materials: Metallic-coated steel sheet, minimum thickness of 0.053 inch (1.3 mm).
 - b. Construction: Full profile welded.

2.4 EXTERIOR STANDARD STEEL DOORS AND FRAMES

- A. Construct hollow-metal doors and frames to comply with standards indicated for materials, fabrication, hardware locations, hardware reinforcement, tolerances, and clearances, and as specified.
- B. Extra-Heavy-Duty Doors and Frames: ANSI/SDI A250.8, Level 3; ANSI/SDI A250.4, Level A. At locations indicated in the Door and Frame Schedule.
 - 1. Doors:
 - a. Type: As indicated in the Door and Frame Schedule.
 - b. Thickness: 1-3/4 inches (44.5 mm).
 - c. Face: Metallic-coated steel sheet, minimum thickness of 0.053 inch (1.3 mm), with minimum A60 (ZF180) coating.

Weedsport Addition to Maintenance Section and Roof Replacement, MP 304.2

- d. Edge Construction: Model 2, Seamless.
 - e. Top Edge Closures: Close top edges of doors with flush closures of same material as face sheets. Seal joints against water penetration.
 - f. Bottom Edges: Close bottom edges of doors with end closures or channels of same material as face sheets. Provide weep-hole openings in bottoms of exterior doors to permit moisture to escape.
 - g. Core: Polyurethane or Polyisocyanurate.
2. Frames:
- a. Materials: Metallic-coated steel sheet, minimum thickness of 0.067 inch (1.7 mm), with minimum A60 (ZF180) coating.
 - b. Construction: Full profile welded.

2.5 FRAME ANCHORS**A. Jamb Anchors:**

- 1. Type: Anchors of minimum size and type required by applicable door and frame standard, and suitable for performance level indicated.
- 2. Quantity: Minimum of three anchors per jamb, with one additional anchor for frames with no floor anchor. Provide one additional anchor for each 24 inches (610 mm) of frame height above 7 feet (2.1 m).
- 3. Postinstalled Expansion Anchor: Minimum 3/8-inch- (9.5-mm-) diameter bolts with expansion shields or inserts, with manufacturer's standard pipe spacer.

B. Floor Anchors: Provide floor anchors for each jamb and mullion that extends to floor.**C. Floor Anchors for Concrete Slabs with Underlayment: Adjustable-type anchors with extension clips, allowing not less than 2-inch (51-mm) height adjustment. Terminate bottom of frames at top of underlayment.****D. Material: ASTM A879/A879M, Commercial Steel (CS), 04Z (12G) coating designation; mill phosphatized.**

- 1. For anchors built into exterior walls, steel sheet complying with ASTM A1008/A1008M or ASTM A1011/A1011M; hot-dip galvanized according to ASTM A153/A153M, Class B.

2.6 MATERIALS**A. Cold-Rolled Steel Sheet: ASTM A1008/A1008M, Commercial Steel (CS), Type B; suitable for exposed applications.****B. Hot-Rolled Steel Sheet: ASTM A1011/A1011M, Commercial Steel (CS), Type B; free of scale, pitting, or surface defects; pickled and oiled.****C. Metallic-Coated Steel Sheet: ASTM A653/A653M, Commercial Steel (CS), Type B.****D. Inserts, Bolts, and Fasteners: Hot-dip galvanized according to ASTM A153/A153M.****E. Power-Actuated Fasteners in Concrete: Fastener system of type suitable for application indicated, fabricated from corrosion-resistant materials, with clips or other accessory devices for attaching hollow-metal frames of type indicated.**

Weedsport Addition to Maintenance Section and Roof Replacement, MP 304.2

- F. Mineral-Fiber Insulation: ASTM C665, Type I (blankets without membrane facing); consisting of fibers manufactured from slag or rock wool; with maximum flame-spread and smoke-developed indexes of 25 and 50, respectively; passing ASTM E136 for combustion characteristics.
- G. Glazing: Safety Glazing: Where safety glazing is indicated, provide glazing that complies with 16 CFR 1201, Category II.
- H.

2.7 FABRICATION

- A. Door Astragals: Provide overlapping astragal on one leaf of pairs of doors where required by NFPA 80 for fire-performance rating or where indicated. Extend minimum 3/4 inch (19 mm) beyond edge of door on which astragal is mounted or as required to comply with published listing of qualified testing agency.
- B. Hollow-Metal Frames: Fabricate in one piece except where handling and shipping limitations require multiple sections. Where frames are fabricated in sections, provide alignment plates or angles at each joint, fabricated of metal of same or greater thickness as frames.
 - 1. Provide countersunk, flat- or oval-head exposed screws and bolts for exposed fasteners unless otherwise indicated.
 - 2. Door Silencers: Except on weather-stripped frames, drill stops to receive door silencers as follows. Keep holes clear during construction.
 - a. Single-Door Frames: Drill stop in strike jamb to receive three door silencers.
 - b. Double-Door Frames: Drill stop in head jamb to receive two door silencers.
- C. Hardware Preparation: Factory prepare hollow-metal doors and frames to receive templated mortised hardware, and electrical wiring; include cutouts, reinforcement, mortising, drilling, and tapping according to ANSI/SDI A250.6, the Door Hardware Schedule, and templates.
 - 1. Reinforce doors and frames to receive nontemplated, mortised, and surface-mounted door hardware.
 - 2. Comply with BHMA A156.115 for preparing hollow-metal doors and frames for hardware.
- D. Glazed Lites: Provide stops and moldings around glazed lites where indicated. Form corners of stops and moldings with butted or mitered hairline joints.
 - 1. Provide stops and moldings flush with face of door, and with square stops unless otherwise indicated.
 - 2. Multiple Glazed Lites: Provide fixed and removable stops and moldings so that each glazed lite is capable of being removed independently.
 - 3. Provide fixed frame moldings on outside of exterior and on secure side of interior doors and frames. Provide loose stops and moldings on inside of hollow-metal doors and frames.
 - 4. Coordinate rabbet width between fixed and removable stops with glazing and installation types indicated.
 - 5. Provide stops for installation with countersunk flat- or oval-head machine screws spaced uniformly not more than 9 inches (230 mm) o.c. and not more than 2 inches (51 mm) o.c. from each corner.

2.8 STEEL FINISHES

- A. Prime Finish: Clean, pretreat, and apply manufacturer's standard primer.
1. Shop Primer: Manufacturer's standard, fast-curing, lead- and chromate-free primer complying with ANSI/SDI A250.10; recommended by primer manufacturer for substrate; compatible with substrate and field-applied coatings despite prolonged exposure.

PART 3 - EXECUTION**3.1 PREPARATION**

- A. Remove welded-in shipping spreaders installed at factory. Restore exposed finish by grinding, filling, and dressing, as required to make repaired area smooth, flush, and invisible on exposed faces. Touch up factory-applied finishes where spreaders are removed.
- B. Drill and tap doors and frames to receive nontemplated, mortised, and surface-mounted door hardware.

3.2 INSTALLATION

- A. Hollow-Metal Frames: Comply with ANSI/SDI A250.11.
1. Set frames accurately in position; plumbed, aligned, and braced securely until permanent anchors are set. After wall construction is complete, remove temporary braces without damage to completed Work.
 - a. Where frames are fabricated in sections, field splice at approved locations by welding face joint continuously; grind, fill, dress, and make splice smooth, flush, and invisible on exposed faces. Touch-up finishes.
 - b. Install frames with removable stops located on secure side of opening.
 2. Fire-Rated Openings: Install frames according to NFPA 80.
 3. Floor Anchors: Secure with postinstalled expansion anchors.
 - a. Floor anchors may be set with power-actuated fasteners instead of postinstalled expansion anchors if so indicated and approved on Shop Drawings.
 4. Solidly pack mineral-fiber insulation inside frames.
 5. Masonry Walls: Coordinate installation of frames to allow for solidly filling space between frames and masonry with grout or mortar.
 6. In-Place Concrete or Masonry Construction: Secure frames in place with postinstalled expansion anchors. Countersink anchors, and fill and make smooth, flush, and invisible on exposed faces.
 7. Installation Tolerances: Adjust hollow-metal frames to the following tolerances:
 - a. Squareness: Plus or minus 1/16 inch (1.6 mm), measured at door rabbet on a line 90 degrees from jamb perpendicular to frame head.
 - b. Alignment: Plus or minus 1/16 inch (1.6 mm), measured at jambs on a horizontal line parallel to plane of wall.

Weedsport Addition to Maintenance Section and Roof Replacement, MP 304.2

- c. Twist: Plus or minus 1/16 inch (1.6 mm), measured at opposite face corners of jambs on parallel lines, and perpendicular to plane of wall.
 - d. Plumbness: Plus or minus 1/16 inch (1.6 mm), measured at jambs at floor.
- B. Hollow-Metal Doors: Fit and adjust hollow-metal doors accurately in frames, within clearances specified below.
 - 1. Non-Fire-Rated Steel Doors: Comply with ANSI/SDI A250.8.
 - 2. Fire-Rated Doors: Install doors with clearances according to NFPA 80.
 - 3. Smoke-Control Doors: Install doors according to NFPA 105.
- C. Glazing: Coordinate glazing channel dimensions to provide necessary bite on glass, minimum edge and face clearances, and adequate sealant thicknesses, with reasonable tolerances.

3.3 REPAIR

- A. Prime-Coat Touchup: Immediately after erection, sand smooth rusted or damaged areas of prime coat and apply touchup of compatible air-drying, rust-inhibitive primer.
- B. Metallic-Coated Surface Touchup: Clean abraded areas and repair with galvanizing repair paint according to manufacturer's written instructions.
- C. Touchup Painting: Cleaning and touchup painting of abraded areas of paint are specified in painting Sections.

END OF SECTION 081113

SECTION 085113 - ALUMINUM WINDOWS

PART 1 - GENERAL

1.1 SUMMARY

- A. This Section includes fixed and operable aluminum-framed windows for exterior locations.

1.2 DEFINITIONS

- A. Performance class designations according to AAMA/WDMA 101/I.S.2/NAFS:
1. AW: Architectural.
 2. HC: Heavy Commercial.
 3. C: Commercial.
 4. LC: Light Commercial.
 5. R: Residential.
- B. Performance grade number according to AAMA/WDMA 101/I.S.2/NAFS:
1. Design pressure number in pounds force per square foot used to determine the structural test pressure and water test pressure.
- C. Structural Test Pressure: For uniform load structural test, is equivalent to 150 percent of the design pressure.
- D. Minimum Test Size: Smallest size permitted for performance class (gateway test size). Products must be tested at minimum test size or at a size larger than minimum test size to comply with requirements for performance class.

1.3 PERFORMANCE REQUIREMENTS

- A. General: Provide aluminum windows capable of complying with performance requirements indicated, based on testing manufacturer's windows that are representative of those specified, and that are of minimum test size indicated below:
1. Size required by AAMA/WDMA 101/I.S.2/NAFS for gateway performance.
- B. Thermal Movements: Provide aluminum windows, including anchorage, that allow for thermal movements resulting from the following maximum change (range) in ambient and surface temperatures by preventing buckling, opening of joints, overstressing of components, failure of joint sealants, failure of connections, and other detrimental effects. Base engineering calculation on surface temperatures of materials due to both solar heat gain and nighttime-sky heat loss.
1. Temperature Change (Range): 120 deg F, ambient; 180 deg F material surfaces.

1.4 SUBMITTALS

- A. Product Data: Include construction details, material descriptions, fabrication methods, dimensions of individual components and profiles, hardware, finishes, and operating instructions for each type of aluminum window indicated.
- B. Shop Drawings: Include plans, elevations, sections, details, hardware, attachments to other work, operational clearances, installation details, and the following:
1. Mullion details, including reinforcement and stiffeners.
 2. Joinery details.
 3. Expansion provisions.
 4. Flashing and drainage details.

Weedsport Addition to Maintenance Section and Roof Replacement, MP 304.2

5. Weather-stripping details.
 6. Thermal-break details.
 7. Glazing details.
 8. Window cleaning provisions.
- C. Samples for Initial Selection: For units with factory-applied color finishes.
1. Include similar Samples of hardware and accessories involving color selection.
- D. Product Schedule: For aluminum windows. Use same designations indicated on Drawings.
- E. Qualification Data: For Installer.
- F. Maintenance Data: For operable window sash, operating hardware, weather stripping and finishes to include in maintenance manuals.
- G. Warranty: Special warranty specified in this Section.

1.5 QUALITY ASSURANCE

- A. Installer Qualifications: An installer acceptable to aluminum window manufacturer for installation of units required for this Project.
- B. Manufacturer Qualifications: A manufacturer capable of fabricating aluminum windows that meet or exceed performance requirements indicated and of documenting this performance by inclusion in lists and by labels, test reports, and calculations.
- C. Source Limitations: Obtain aluminum windows through one source from a single manufacturer.
- D. Product Options: Drawings indicate size, profiles, and dimensional requirements of aluminum windows and are based on the specific system indicated. Do not modify size and dimensional requirements.
1. Do not modify intended aesthetic effects, as judged solely by Architect, except with Architect's approval. If modifications are proposed, submit comprehensive explanatory data to Architect for review.
- E. Preinstallation Conference: Conduct conference at Project site.
- F. Test reports shall be accompanied by the window manufacturer's letter of certification, stating the tested window meets or exceeds the referenced criteria for the appropriate window type.

1.6 PROJECT CONDITIONS

- A. Field Measurements: Verify aluminum window openings by field measurements before fabrication and indicate measurements on Shop Drawings.
1. Established Dimensions: Where field measurements cannot be made without delaying the Work, establish opening dimensions and proceed with fabricating aluminum windows without field measurements. Coordinate wall construction to ensure that actual opening dimensions correspond to established dimensions.

1.7 WARRANTY

- A. Special Warranty: Manufacturer's standard form in which manufacturer agrees to repair or replace aluminum windows that fail in materials or workmanship within specified warranty period.
1. Failures include, but are not limited to, the following:
 - a. Failure to meet performance requirements.

Weedsport Addition to Maintenance Section and Roof Replacement, MP 304.2

- b. Structural failures including excessive deflection, water leakage, air infiltration, or condensation.
 - c. Faulty operation of movable sash and hardware.
 - d. Deterioration of metals, other materials, and metal finishes beyond normal weathering.
 - e. Failure of insulating glass.
2. Warranty Period:
- a. Window: Ten years from date of Substantial Completion.
 - b. Glazing: Ten years from date of Substantial Completion.
 - c. Metal Finish: 15 years from date of Substantial Completion.

PART 2 - PRODUCTS

2.1 MATERIALS

- A. Aluminum Extrusions: Alloy and temper recommended by aluminum window manufacturer for strength, corrosion resistance, and application of required finish, but not less than 22,000-psi ultimate tensile strength, not less than 16,000-psi minimum yield strength, and not less than 0.062-inch thickness at any location for the main frame and sash members.
- B. Fasteners: Aluminum, nonmagnetic stainless steel, epoxy adhesive, or other materials warranted by manufacturer to be noncorrosive and compatible with aluminum window members, trim, hardware, anchors, and other components.
 - 1. Reinforcement: Where fasteners screw anchor into aluminum less than 0.125 inch thick, reinforce interior with aluminum or nonmagnetic stainless steel to receive screw threads, or provide standard, noncorrosive, pressed-in, splined grommet nuts.
 - 2. Exposed Fasteners: Unless unavoidable for applying hardware, do not use exposed fasteners. For application of hardware, use fasteners that match finish of member or hardware being fastened, as appropriate.
- C. Anchors, Clips, and Accessories: Aluminum, nonmagnetic stainless steel, or zinc-coated steel or iron complying with ASTM B 633 for SC 3 severe service conditions; provide sufficient strength to withstand design pressure indicated.
- D. Reinforcing Members: Aluminum, nonmagnetic stainless steel, or nickel/chrome-plated steel complying with ASTM B 456 for Type SC 3 severe service conditions, or zinc-coated steel or iron complying with ASTM B 633 for SC 3 severe service conditions; provide sufficient strength to withstand design pressure indicated.
- E. Compression-Type Weather Stripping: Provide compressible weather stripping designed for permanently resilient sealing under bumper or wiper action and for complete concealment when aluminum window is closed.
 - 1. Weather-Stripping Material: Dense elastomeric gaskets complying with ASTM C 864.
 - 2. Configuration: Bulb- or fin-type at exterior vent member; fin-type at interior.
- F. Sliding-Type Weather Stripping: Provide woven-pile weather stripping of wool, polypropylene, or nylon pile and resin-impregnated backing fabric. Comply with AAMA 701/702.
 - 1. Weather Seals: Provide weather stripping with integral barrier fin or fins of semirigid, polypropylene sheet or polypropylene-coated material. Comply with AAMA 701/702.
- G. Sealant: For sealants required within fabricated windows, provide window manufacturer's standard, permanently elastic, nonshrinking, and nonmigrating type recommended by sealant manufacturer for joint size and movement.

Weedsport Addition to Maintenance Section and Roof Replacement, MP 304.2

- H. Thermal Barrier:
1. All exterior aluminum shall be separated from interior aluminum by a rigid, structural thermal barrier. For purposes of this specification, a structural thermal barrier is defined as a system that shall transfer shear during bending and therefore, promote composite action between the exterior and interior extrusions.
 2. The thermal barrier shall be thermal struts, consisting of glass reinforced polyamide nylon, mechanically crimped in raceways extruded in the exterior and interior extrusions.
 3. Poured and debrided urethane thermal barriers shall not be permitted.

2.2 WINDOWS

- A. Window Type: Fixed Windows.
1. AAMA/WDMA Performance Requirements: Provide aluminum windows of performance indicated that comply with AAMA/WDMA 101/I.S.2/NAFS unless more stringent performance requirements are indicated.
 2. Basis-of-Design Product: Subject to compliance with requirements, provide "Series FX32 Thermal AW-PG150-FW fixed" by EFCO or a comparable product by one of the following:
 - a. EFCO Corporation.
 - b. Graham Architectural Products Corp.
 - c. Kawneer; an Alcoa Company.
 - d. TRACO.
 - e. Wausau Window and Wall Systems.
 3. Laboratory Testing and Performance Requirements
 - a. Test Units
 - 1) Air, water, and structural test unit shall conform to requirements set forth in AAMA/WDMA/CSA 101/I.S.2/A440 – 17 and manufacturer's standard locking/operating hardware and insulated glazing configuration.
 - 2) Thermal test unit sizes shall be 24" (610 mm) x 60" (1524 mm).
 - b. Test Procedures and Performances
 - 1) Windows shall conform to all AAMA/WDMA/CSA 101/I.S.2/A440-17 requirements for window performance class AW. In addition, the following specific performance requirements shall be met.
 - 2) Air Infiltration Test
 - a) Test unit in accordance with ASTM E 283 at a static air pressure difference of 6.24 psf (299 Pa).
 - b) Air infiltration shall not exceed .30 cfm/SF (.50 l/s•m²) of unit.
 - 3) Water Resistance Test
 - a) Test unit in accordance with ASTM E 331/ASTM E 547 at a static air pressure difference of 15.0 psf (720 Pa).
 - b) There shall be no uncontrolled water leakage.
 - 4) Uniform Load Deflection Test
 - a) Test unit in accordance with ASTM E 330 at a static air pressure difference of 225.0 psf (10800 Pa), positive and negative pressure.
 - b) No member shall deflect over L/175 of its span.
 - 5) Uniform Load Structural Test
 - a) Test unit in accordance with ASTM E 330 at a static air pressure difference of 240.0 psf (11,491 Pa), both positive and negative.
 - b) At conclusion of test there shall be no glass breakage, permanent damage to fasteners, hardware parts, support arms or actuating

Weedsport Addition to Maintenance Section and Roof Replacement, MP 304.2

mechanisms, nor any other damage that would cause the window to be inoperable.

- 6) Condensation Resistance Test (CRF)
 - a) Test unit in accordance with AAMA 1503.1.
 - b) Condensation Resistance Factor (CRF) shall not be less than 73 (frame) when glazed with .24 center of glass U-Factor.
- 7) Thermal Transmittance Test (Conductive U-Factor)
 - a) Test unit in accordance with NFRC 100-2010.
 - b) Conductive thermal transmittance (U-Factor) shall not be more than .33 BTU/hr•ft²•°F when glazed with .24 center of glass U-Factor.

B. Window Type: Slider Windows.

1. AAMA/WDMA Performance Requirements: Provide aluminum windows of performance indicated that comply with AAMA/WDMA 101/I.S.2/NAFS unless more stringent performance requirements are indicated.
2. Basis-of-Design Product: Subject to compliance with requirements, provide "Series 3500 Thermal AW-PG55-HS Horizontal Sliding by EFCO or a comparable product by one of the following:
 - a. EFCO Corporation.
 - b. Graham Architectural Products Corp.
 - c. Kawneer; an Alcoa Company.
 - d. TRACO.
 - e. Wausau Window and Wall Systems.
3. Laboratory Testing and Performance Requirements
 - a. Test Units
 - 1) Air, water, and structural test unit shall conform to requirements set forth in AAMA/WDMA/CSA 101/I.S.2/A440-08 and manufacturer's standard locking/operating hardware and insulated glazing configuration.
 - 2) Thermal test unit sizes shall be 72" (1828 mm) x 48" (1219 mm). Unit shall consist of a single horizontal sliding window.
 - b. Test Procedures and Performances
 - 1) Windows shall conform to all AAMA/WDMA/CSA 101/I.S.2/A440-08 requirements for window performance class AW. In addition, the following specific performance requirements shall be met.
 - c. Life Cycle Testing
 - 1) Test in accordance with AAMA 910. There shall be no damage to fasteners, hardware parts, support arms, activating mechanisms, or any other damage that would cause the window to be inoperable. Air infiltration and water resistance tests shall not exceed specified requirements.
 - d. Air Infiltration Test
 - 1) With ventilators closed and locked, test unit in accordance with ASTM E 283 at a static air pressure difference of 6.24 psf (299 Pa).
 - 2) Air infiltration shall not exceed .10 cfm/SF (.50 l/s•m²) of unit.
 - e. Water Resistance Test
 - 1) With ventilators closed and locked, test unit in accordance with ASTM E 331/ASTM E 547 at a static air pressure difference of 12.0 psf (575 Pa).
 - 2) There shall be no uncontrolled water leakage.
 - f. Uniform Load Deflection Test

Weedsport Addition to Maintenance Section and Roof Replacement, MP 304.2

- 1) With ventilators closed and locked, test unit in accordance with ASTM E 330 at a static air pressure difference of 50 psf (2394 Pa), positive and negative pressure.
 - 2) No member shall deflect over L/175 of its span.
 - g. Uniform Load Structural Test
 - 1) With ventilators closed and locked, test unit in accordance with ASTM E 330 at a static air pressure difference of 82.5 psf (3591 Pa), both positive and negative.
 - 2) At conclusion of test there shall be no glass breakage, permanent damage to fasteners, hardware parts, support arms or actuating mechanisms, nor any other damage that would cause the window to be inoperable.
 - h. Forced Entry Resistance
 - 1) Windows shall be tested in accordance to ASTM F 588 or AAMA 1302.5 and meet the requirements of performance level 40
 - i. Condensation Resistance Test (CRF)
 - 1) Test unit in accordance with AAMA 1503.1.
 - 2) Condensation Resistance Factor (CRF) shall not be less than 60 (frame) when glazed with .024 center of glass U-Factor.
 - j. Condensation Resistance (CR)
 - 1) With ventilators closed and locked, test unit in accordance with NFRC 500-2010.
 - 2) Condensation Resistance (CR) shall not be less than 37 when glazed with 0.24 center of glass U-Factor.
 - k. Thermal Transmittance Test (Conductive U-Factor)
 - 1) With ventilators closed and locked, test unit in accordance with NFRC 100-2010.
 - 2) Conductive thermal transmittance (U-Factor) shall not be more than .46 BTU/hr•ft²•°F (2.61 W/m²•K) when glazed with 0.24 center of glass U-Factor.
- C. Hardware
1. Concealed plunger lock in the meeting rail with a flush mounted actuating handle.
 2. Sash shall ride on steel ball bearing rollers and a raised track, so dirt will not interfere with normal operation.
- D. Weather-Strip
1. All primary weather-strip shall be E-lon or equal.
- E. Operating Force and Auxiliary (Durability) Tests: Comply with AAMA/ WDMA 101/ I.S.2/ NAFS for operating window types indicated.
- F. Project Wind Loads
1. The system shall be designed to withstand the following loads normal to the plane of the wall:
 - a. Positive pressure of 25 psf
 - b. Negative pressure of 25 psf
- 2.3 GLAZING**
- A. Glass Type Low-E-coated, clear insulating glass.

Weedsport Addition to Maintenance Section and Roof Replacement, MP 304.2

1. Basis-of-Design Product: Guardian SN 68 / IS 20 Unit
2. Overall Unit Thickness: 1 inch.
3. Minimum Thickness of Outdoor Lite: 6 mm.
4. Outdoor Lite: Sun Guard SN68 on Clear Tempered.
5. Interspace Content: Argon.
6. Indoor Lite: Sun Guard IS 20 on Clear laminated glass with two plies of heat-strengthened float glass.
 - a. Minimum Thickness of Each Glass Ply: 3 mm.
 - b. Interlayer Thickness: 0.030 inch.
7. Low-E Coating: Second and Sixth surface.
8. Winter Nighttime U-Factor: 0.20 maximum.
9. Summer Daytime U-Factor: 0.22 maximum.
10. Visible Light Transmittance: 68 percent minimum.
11. Solar Heat Gain Coefficient: 0.36 maximum.
12. Safety glazing required.

2.4 HARDWARE

- A. General: Provide manufacturer's standard hardware fabricated from aluminum, stainless steel, carbon steel complying with AAMA 907, or other corrosion-resistant material compatible with aluminum; designed to smoothly operate, tightly close, and securely lock aluminum windows, and sized to accommodate sash or ventilator weight and dimensions. Do not use aluminum in frictional contact with other metals. Where exposed, provide extruded, cast, or wrought aluminum, die-cast zinc with special coating finish, or nonmagnetic stainless steel. Also as specified in 1.10 above.
- B. Limit Devices: Provide limit devices designed to restrict sash or ventilator opening.
 1. Safety Devices: Limit clear opening to 6 inches for ventilation; with custodial key release.

2.5 INSECT SCREENS

- A. General: Design windows and hardware to accommodate screens in a tight-fitting, removable arrangement, with a minimum of exposed fasteners and latches. Fabricate insect screens to fully integrate with window frame. Locate screens on inside or outside dependent on window type of window and provide for each operable exterior sash or ventilator.
 1. Comply with SMA 1004, "Specifications for Aluminum Tubular Frame Screens for Windows," for minimum standards of appearance, fabrication, attachment of screen fabric, hardware, and accessories unless more stringent requirements are indicated.
- B. Aluminum Insect Screen Frames: Manufacturer's standard aluminum alloy complying with SMA 1004. Fabricate frames with mitered or coped joints or corner extrusions, concealed fasteners, and removable PVC spline/anchor concealing edge of frame.
 1. Extruded-Aluminum or Aluminum Tubular Framing Sections and Cross Braces: Not less than 0.050-inch wall thickness.
 2. Finish: Match aluminum window members.
- C. Aluminum Wire Fabric: 18-by-16 mesh of 0.011-inch- diameter, coated aluminum wire.
 1. Wire-Fabric Finish: Black.

Weedsport Addition to Maintenance Section and Roof Replacement, MP 304.2

- D. Wickets: Provide sliding or hinged wickets, framed and trimmed for a tight fit and for durability during handling.

2.6 ACCESSORIES

- A. Provide manufacturer's standard subframe and subsill components with integral vapor barrier flanges and extended snap-on exterior trim for both fixed and operable windows.

2.7 FABRICATION

- A. Fabricate aluminum windows in sizes indicated. Include a complete system for assembling components and anchoring windows.
- B. Fabricate aluminum windows that are reglazable without dismantling sash or ventilator framing.
- C. All aluminum frame extrusions shall have a minimum wall thickness of .080" (3mm).
- D. Mechanical fasteners, welded components, and hardware items shall not bridge thermal barriers. Thermal barriers shall align at all frame corners.
- E. Depth of frame and vent shall not be less than 3 ¼" (82mm).
- F. All frame members shall be able to accommodate separate interior and exterior finishes and colors.
- G. Frame components shall be mechanically fastened.
- H. Weather Stripping: Provide full-perimeter weather stripping for each operable sash and ventilator.
 - 1. Vertically Pivoted Windows: Provide double-row weather stripping.
- I. Weep Holes: Provide weep holes and internal passages to conduct infiltrating water to exterior.
- J. Mullions: Provide mullions and cover plates as shown, matching window units, complete with anchors for support to structure and installation of window units. Allow for erection tolerances and provide for movement of window units due to thermal expansion and building deflections, as indicated. Provide mullions and cover plates capable of withstanding design loads of window units.
- K. All units shall be glazed with the manufacturer's standard sealant process provided the glass is held in place by a removable, extruded aluminum, glazing bead. The glazing bead must be isolated from the glazing material by a gasket.
- L. All units shall be glazed with a minimum of 9/16" glass bite.

2.8 FINISHES, GENERAL

- A. Comply with NAAMM's "Metal Finishes Manual for Architectural and Metal Products" for recommendations for applying and designating finishes.
- B. Protect mechanical finishes on exposed surfaces from damage by applying a strippable, temporary protective covering before shipping.
- C. Appearance of Finished Work: Variations in appearance of abutting or adjacent pieces are acceptable if they are within one-half of the range of approved Samples. Noticeable variations in the same piece are not acceptable. Variations in appearance of other components are acceptable if they are within the range of approved Samples and are assembled or installed to minimize contrast.

Weedsport Addition to Maintenance Section and Roof Replacement, MP 304.2

2.9 ALUMINUM FINISHES

- A. Finish designations prefixed by AA comply with the system established by the Aluminum Association for designating aluminum finishes.
- A. High-Performance Organic Finish (Two-Coat Fluoropolymer): AA-C12C40R1x (Chemical Finish: cleaned with inhibited chemicals; Chemical Finish: conversion coating; Organic Coating: manufacturer's standard two-coat, thermocured system consisting of specially formulated inhibitive primer and fluoropolymer color topcoat containing not less than 70 percent polyvinylidene fluoride resin by weight). Prepare, pretreat, and apply coating to exposed metal surfaces to comply with AAMA 2605 and with coating and resin manufacturers' written instructions.
 - 1. Color and Gloss: As selected by Architect from custom color selection.

PART 3 - EXECUTION**3.1 EXAMINATION**

- A. Examine openings, substrates, structural support, anchorage, and conditions, with Installer present, for compliance with requirements for installation tolerances and other conditions affecting performance of work. Verify rough opening dimensions, levelness of sill plate, and operational clearances. Examine wall flashings, vapor retarders, water and weather barriers, and other built-in components to ensure a coordinated, weathertight window installation.
 - 1. Masonry Surfaces: Visibly dry and free of excess mortar, sand, and other construction debris.
 - 2. Wood Frame Walls: Dry, clean, sound, well nailed, free of voids, and without offsets at joints. Ensure that nail heads are driven flush with surfaces in opening and within 3 inches of opening.
 - 3. Metal Surfaces: Dry; clean; free of grease, oil, dirt, rust, corrosion, and welding slag; without sharp edges or offsets at joints.
 - 4. Proceed with installation only after unsatisfactory conditions have been corrected.

3.2 INSTALLATION

- A. Comply with Drawings, Shop Drawings, and manufacturer's written instructions for installing windows, hardware, accessories, and other components.
- B. Install windows level, plumb, square, true to line, without distortion or impeding thermal movement, anchored securely in place to structural support, and in proper relation to wall flashing and other adjacent construction.
- C. Set sill members in bed of sealant or with gaskets, as indicated, for weathertight construction.
- D. Install windows and components to drain condensation, water penetrating joints, and moisture migrating within windows to the exterior.
- E. Separate aluminum and other corrodible surfaces from sources of corrosion or electrolytic action at points of contact with other materials.

3.3 FIELD QUALITY CONTROL

- A. Testing Agency: Owner may engage a qualified testing agency to perform tests and inspections and prepare test reports.

Weedsport Addition to Maintenance Section and Roof Replacement, MP 304.2

1. Testing and inspecting agency will interpret tests and state in each report whether tested work complies with or deviates from requirements.
- B. Testing Services: Testing and inspecting of installed windows shall take place as follows:
 1. Testing Methodology: Testing of windows for air infiltration and water resistance shall be performed according to AAMA 502, Test Method A or B, by applying same test pressures required to determine compliance with AAMA/WDMA 101/I.S.2/NAFS in Part 1 "Performance Requirements" Article.
- C. Remove and replace noncomplying aluminum window and retest as specified above.
- D. Additional testing and inspecting, at Contractor's expense, will be performed to determine compliance of replaced or additional work with specified requirements.

3.4 ADJUSTING, CLEANING, AND PROTECTION

- A. Adjust operating sashes and ventilators, screens, hardware, and accessories for a tight fit at contact points and weather stripping for smooth operation and weathertight closure. Lubricate hardware and moving parts.
- B. Clean aluminum surfaces immediately after installing windows. Avoid damaging protective coatings and finishes. Remove excess sealants, glazing materials, dirt, and other substances.
- C. Clean factory-glazed glass immediately after installing windows. Comply with manufacturer's written recommendations for final cleaning and maintenance. Remove nonpermanent labels, and clean surfaces.
- D. Remove and replace glass that has been broken, chipped, cracked, abraded, or damaged during construction period.
- E. Protect window surfaces from contact with contaminating substances resulting from construction operations. In addition, monitor window surfaces adjacent to and below exterior concrete and masonry surfaces during construction for presence of dirt, scum, alkaline deposits, stains, or other contaminants. If contaminating substances do contact window surfaces, remove contaminants immediately according to manufacturer's written recommendations.

END OF SECTION 08 5113

SECTION 087100 – DOOR HARDWARE

PART 1 - GENERAL

1.1 SUMMARY

- A. This Section includes commercial door hardware for the following:
 - 1. Swinging doors.
- B. Door hardware includes, but is not necessarily limited to, the following:
 - 1. Mechanical door hardware.
- C. Related Sections:
 - 1. Division 08 Section “Hollow Metal Doors and Frames”.
- D. Codes and References: Comply with the version year adopted by the Authority Having Jurisdiction.
 - 1. ANSI A117.1 - Accessible and Usable Buildings and Facilities.
 - 2. ICC/IBC - International Building Code.
 - 3. NFPA 70 - National Electrical Code.
 - 4. NFPA 80 - Fire Doors and Windows.
 - 5. NFPA 101 - Life Safety Code.
 - 6. NFPA 105 - Installation of Smoke Door Assemblies.
 - 7. State Building Codes, Local Amendments.
- E. Standards: All hardware specified herein shall comply with the following industry standards:
 - 1. ANSI/BHMA Certified Product Standards - A156 Series
 - 2. UL10C – Positive Pressure Fire Tests of Door Assemblies

1.2 SUBMITTALS

- A. Product Data: Manufacturer's product data sheets including installation details, material descriptions, dimensions of individual components and profiles, operational descriptions and finishes.
- B. Door Hardware Schedule: Prepared by or under the supervision of supplier, detailing fabrication and assembly of door hardware, as well as procedures and diagrams. Coordinate the final Door Hardware Schedule with doors, frames, and related work to ensure proper size, thickness, hand, function, and finish of door hardware.
 - 1. Format: Comply with scheduling sequence and vertical format in DHI's "Sequence and Format for the Hardware Schedule."
 - 2. Organization: Organize the Door Hardware Schedule into door hardware sets indicating complete designations of every item required for each door or opening. Organize door hardware sets in same order as in the Door Hardware Sets at the end of Part 3. Submittals that do not follow the same format and order as the Door Hardware Sets will be rejected and subject to resubmission.
 - 3. Content: Include the following information:
 - a. Type, style, function, size, label, hand, and finish of each door hardware item.
 - b. Manufacturer of each item.
 - c. Fastenings and other pertinent information.

Weedsport Addition to Maintenance Section and Roof Replacement, MP 304.2

- d. Location of door hardware set, cross-referenced to Drawings, both on floor plans and in door and frame schedule.
 - e. Explanation of abbreviations, symbols, and codes contained in schedule.
 - f. Mounting locations for door hardware.
 - g. Door and frame sizes and materials.
 - h. Warranty information for each product.
4. Submittal Sequence: Submit the final Door Hardware Schedule at earliest possible date, particularly where approval of the Door Hardware Schedule must precede fabrication of other work that is critical in the Project construction schedule. Include Product Data, Samples, Shop Drawings of other work affected by door hardware, and other information essential to the coordinated review of the Door Hardware Schedule.
- C. Shop Drawings: Details of electrified access control hardware indicating the following:
- 1. Wiring Diagrams: Upon receipt of approved schedules, submit detailed system wiring diagrams for power, signaling, monitoring, communication, and control of the access control system electrified hardware. Differentiate between manufacturer-installed and field-installed wiring. Include the following:
 - a. Elevation diagram of each unique access controlled opening showing location and interconnection of major system components with respect to their placement in the respective door openings.
 - b. Complete (risers, point-to-point) access control system block wiring diagrams.
 - c. Wiring instructions for each electronic component scheduled herein.
 - 2. Electrical Coordination: Coordinate with related sections the voltages and wiring details required at electrically controlled and operated hardware openings.
- D. Keying Schedule: After a keying meeting with the owner has taken place prepare a separate keying schedule detailing final instructions. Submit the keying schedule in electronic format. Include keying system explanation, door numbers, key set symbols, hardware set numbers and special instructions. Owner must approve submitted keying schedule prior to the ordering of permanent cylinders/cores.
- E. Informational Submittals:
- 1. Product Test Reports: Indicating compliance with cycle testing requirements, based on evaluation of comprehensive tests performed by manufacturer and witnessed by a qualified independent testing agency.
- F. Operating and Maintenance Manuals: Provide manufacturers operating and maintenance manuals for each item comprising the complete door hardware installation in quantity as required in Division 01, Operation and Maintenance Data.

1.3 QUALITY ASSURANCE

- A. Manufacturers Qualifications: Engage qualified manufacturers with a minimum 5 years of documented experience in producing hardware and equipment similar to that indicated for this Project and that have a proven record of successful in-service performance.
- B. Installer Qualifications: A minimum 3 years documented experience installing both standard and electrified door hardware similar in material, design, and extent to that indicated for this Project and whose work has resulted in construction with a record of successful in-service performance.

Weedsport Addition to Maintenance Section and Roof Replacement, MP 304.2

- C. Door Hardware Supplier Qualifications: Experienced commercial door hardware distributors with a minimum 5 years documented experience supplying both mechanical and electromechanical hardware installations comparable in material, design, and extent to that indicated for this Project. Supplier recognized as a factory direct distributor by the manufacturers of the primary materials with a warehousing facility in Project's vicinity. Supplier to have on staff a certified Architectural Hardware Consultant (AHC) available during the course of the Work to consult with Contractor, Architect, and Owner concerning both standard and electromechanical door hardware and keying.
- D. Source Limitations: Obtain each type and variety of door hardware specified in this section from a single source unless otherwise indicated.
 - 1. Electrified modifications or enhancements made to a source manufacturer's product line by a secondary or third party source will not be accepted.
 - 2. Provide electromechanical door hardware from the same manufacturer as mechanical door hardware, unless otherwise indicated.
- E. Each unit to bear third party permanent label demonstrating compliance with the referenced standards.
- F. Keying Conference: Conduct a conference with the Owner to finalize keying requirements and obtain final instructions in writing. Keying conference to incorporate the following criteria into the final keying schedule document:
 - 1. Function of building, purpose of each area and degree of security required.
 - 2. Plans for existing and future key system expansion.
 - 3. Requirements for key control storage and software.
 - 4. Installation of permanent keys, cylinder cores and software.
 - 5. Address and requirements for delivery of keys.

1.4 DELIVERY, STORAGE, AND HANDLING

- A. Inventory door hardware on receipt and provide secure lock-up and shelving for door hardware delivered to Project site. Do not store electronic access control hardware, software or accessories at Project site without prior authorization.
- B. Tag each item or package separately with identification related to the final Door Hardware Schedule, and include basic installation instructions with each item or package.
- C. Deliver, as applicable, permanent keys, cylinders, cores, access control credentials, software and related accessories directly to Owner via registered mail or overnight package service. Instructions for delivery to the Owner shall be established at the "Keying Conference".

1.5 COORDINATION

- A. Templates: Obtain and distribute to the parties involved templates for doors, frames, and other work specified to be factory prepared for installing standard and electrified hardware. Check Shop Drawings of other work to confirm that adequate provisions are made for locating and installing hardware to comply with indicated requirements.
- B. Door Hardware and Electrical Connections: Coordinate the layout and installation of scheduled electrified door hardware and related access control equipment with required connections to source power junction boxes, low voltage power supplies, detection and monitoring hardware, and fire and detection alarm systems.

Weedsport Addition to Maintenance Section and Roof Replacement, MP 304.2

- C. Door and Frame Preparation: Doors and corresponding frames are to be prepared, reinforced and pre-wired (if applicable) to receive the installation of the specified electrified, monitoring, signaling and access control system hardware without additional in-field modifications.

1.6 WARRANTY

- A. General Warranty: Reference Division 01, General Requirements. Special warranties specified in this Article shall not deprive Owner of other rights Owner may have under other provisions of the Contract Documents and shall be in addition to, and run concurrent with, other warranties made by Contractor under requirements of the Contract Documents.
- B. Warranty Period: Written warranty, executed by manufacturer(s), agreeing to repair or replace components of standard and electrified door hardware that fails in materials or workmanship within specified warranty period after final acceptance by the Owner. Failures include, but are not limited to, the following:
1. Structural failures including excessive deflection, cracking, or breakage.
 2. Faulty operation of the hardware.
 3. Deterioration of metals, metal finishes, and other materials beyond normal weathering.
 4. Electrical component defects and failures within the systems operation.
- C. Standard Warranty Period: One year from date of Substantial Completion, unless otherwise indicated.
- D. Special Warranty Periods:
1. Ten years for mortise locks and latches.
 2. Five years for exit hardware.
 3. Twenty five years for manual surface door closer bodies.
 4. Two years for electromechanical door hardware.

1.7 MAINTENANCE SERVICE

- A. Maintenance Tools and Instructions: Furnish a complete set of specialized tools and maintenance instructions as needed for Owner's continued adjustment, maintenance, and removal and replacement of door hardware.

PART 2 - PRODUCTS**2.1 SCHEDULED DOOR HARDWARE**

- A. General: Provide door hardware for each door to comply with requirements in Door Hardware Sets and each referenced section that products are to be supplied under.
- B. Designations: Requirements for quantity, item, size, finish or color, grade, function, and other distinctive qualities of each type of door hardware are indicated in the Door Hardware Sets at the end of Part 3. Products are identified by using door hardware designations, as follows:
- C. Named Manufacturer's Products: Product designation and manufacturer are listed for each door hardware type required for the purpose of establishing requirements. Manufacturers' names are abbreviated in the Door Hardware Schedule.

Weedsport Addition to Maintenance Section and Roof Replacement, MP 304.2

- D. Substitutions: Requests for substitution and product approval for inclusive mechanical and electromechanical door hardware in compliance with the specifications must be submitted in writing and in accordance with the procedures and time frames outlined in Division 01, Substitution Procedures. Approval of requests is at the discretion of the architect, owner, and their designated consultants.

2.2 HANGING DEVICES

- A. Hinges: ANSI/BHMA A156.1 certified butt hinges with number of hinge knuckles as specified in the Door Hardware Sets.
1. Quantity: Provide the following hinge quantity, unless otherwise indicated:
 - a. Two Hinges: For doors with heights up to 60 inches.
 - b. Three Hinges: For doors with heights 61 to 90 inches.
 - c. Four Hinges: For doors with heights 91 to 120 inches.
 - d. For doors with heights more than 120 inches, provide 4 hinges, plus 1 hinge for every 30 inches of door height greater than 120 inches.
 2. Hinge Size: Provide the following, unless otherwise indicated, with hinge widths sized for door thickness and clearances required:
 - a. Widths up to 3'0": 4-1/2" standard or heavy weight as specified.
 - b. Sizes from 3'1" to 4'0": 5" standard or heavy weight as specified.
 3. Hinge Weight and Base Material: Unless otherwise indicated, provide the following:
 - a. Exterior Doors: Heavy weight, non-ferrous, ball bearing or oil impregnated bearing hinges unless Hardware Sets indicate standard weight.
 - b. Interior Doors: Standard weight, steel, ball bearing or oil impregnated bearing hinges unless Hardware Sets indicate heavy weight.
 4. Hinge Options: Comply with the following where indicated in the Hardware Sets or on Drawings:
 - a. Non-removable Pins: Provide set screw in hinge barrel that, when tightened into a groove in hinge pin, prevents removal of pin while door is closed; for the all out-swinging lockable doors.
 5. Acceptable Manufacturers:
 - a. Stanley (ST).
 - b. Hager Companies (HA).
 - c. McKinney Products (MK).
- B. Continuous Geared Hinges: ANSI/BHMA A156.26 Grade 1-600 certified continuous geared hinge. with minimum 0.120-inch thick extruded 6060 T6 aluminum alloy hinge leaves and a minimum overall width of 4 inches. Hinges are non-handed, reversible and fabricated to template screw locations. Factory trim hinges to suit door height and prepare for electrical cut-outs.
1. Acceptable Manufacturers:
 - a. Stanley (ST).
 - b. McKinney Products (MK).
 - c. Pemko Manufacturing (PE).

2.3 DOOR OPERATING TRIM

- A. Door Push Plates and Pulls: ANS/BHMA A156.6 certified door pushes and pulls of type and design specified in the Hardware Sets. Coordinate and provide proper width and height as required where conflicting hardware dictates.

Weedsport Addition to Maintenance Section and Roof Replacement, MP 304.2

1. Push/Pull Plates: Minimum .050 inch thick, size as indicated in hardware sets, with beveled edges, secured with exposed screws unless otherwise indicated.
2. Fasteners: Provide manufacturer's designated fastener type as indicated in Hardware Sets.
3. Acceptable Manufacturers:
 - a. Burns Manufacturing (BU).
 - b. Rockwood Manufacturing (RO).
 - c. Trimco (TC).

2.4 CYLINDERS AND KEYING

- A. General: Cylinder manufacturer to have minimum (10) years experience designing secured master key systems and have on record a published security keying system policy.
- B. Source Limitations: Obtain each type of keyed cylinder and keys from the same source manufacturer as locksets and exit devices, unless otherwise indicated.
 1. Acceptable Manufacturers:
 - a. Best – 6 pin interchangeable core
- C. Cylinders: Original manufacturer cylinders complying with the following:
 1. Mortise Type: Threaded cylinders with rings and cams to suit hardware application.
 2. Rim Type: Cylinders with back plate, flat-type vertical or horizontal tailpiece, and raised trim ring.
 3. Bored-Lock Type: Cylinders with tailpieces to suit locks.
 4. Mortise and rim cylinder collars to be solid and recessed to allow the cylinder face to be flush and be free spinning with matching finishes.
 5. Keyway: Coordinate with owner.
- D. Keying System: Each type of lock and cylinders to be factory keyed.
 1. Conduct specified "Keying Conference" to define and document keying system instructions and requirements.
 2. Furnish factory cut, nickel-silver large bow permanently inscribed with a visual key control number as directed by Owner.
- E. Key Quantity: Provide the following minimum number of keys:
 1. Change Keys per Cylinder: Two (2)
 2. Master Keys (per Master Key Level/Group): Five (5).
 3. Construction Control Keys (where required): Two (2).
 4. Permanent Control Keys (where required): Two (2).
- F. Construction Keying: Provide temporary keyed construction cores.
- G. Key Registration List (Bitting List):
 1. Provide keying transcript list to Owner's representative in the proper format for importing into key control software.
 2. Provide transcript list in writing or electronic file as directed by the Owner.

2.5 MECHANICAL LOCKS AND LATCHING DEVICES

- A. Mortise Locksets, Grade 1 (Heavy Duty): ANSI/BHMA A156.13, Series 1000, Operational Grade 1 certified. Locksets are to be manufactured with a corrosion resistant steel case and be field-reversible for handing without disassembly of the lock body.

Weedsport Addition to Maintenance Section and Roof Replacement, MP 304.2

1. Extended cycle test: Locks to have been cycle tested in ordinance with ANSI/BHMA 156.13 requirements to 10 million cycles.
 2. Acceptable Manufacturers:
 - a. Stanley Best 45H series
 - b. Corbin Russwin Hardware (RU) – ML2000 Series.
 - c. Schlage (SC) – L9000 Series.
- B. Cylindrical Locksets, Grade 1 (Heavy Duty): ANSI/BHMA A156.2, Series 4000, Grade 1 certified cylindrical (bored) locksets furnished in the functions as specified in the Hardware Sets. Lock chassis fabricated of heavy gauge steel, zinc dichromate plated, with through-bolted application. Furnish with solid cast levers, standard 2 3/4" backset, and 1/2" (3/4" at rated paired openings) throw brass or stainless steel latchbolt. Locks are to be non-handed and fully field reversible.
1. Acceptable Manufacturers:
 - a. Stanley Best 9K series
 - b. Corbin Russwin Hardware (RU) – CL3100 Series.
 - c. Schlage (SC) – ND Series Series.

2.6 LOCK AND LATCH STRIKES

- A. Strikes: Provide manufacturer's standard strike with strike box for each latch or lock bolt, with curved lip extended to protect frame, finished to match door hardware set, unless otherwise indicated, and as follows:
1. Flat-Lip Strikes: For locks with three-piece antifriction latchbolts, as recommended by manufacturer.
 2. Extra-Long-Lip Strikes: For locks used on frames with applied wood casing trim.
 3. Aluminum-Frame Strike Box: Provide manufacturer's special strike box fabricated for aluminum framing.
 4. Double-lipped strikes: For locks at double acting doors. Furnish with retractable stop for rescue hardware applications.
- B. Standards: Comply with the following:
1. Strikes for Mortise Locks and Latches: BHMA A156.13.
 2. Strikes for Bored Locks and Latches: BHMA A156.2.
 3. Strikes for Auxiliary Deadlocks: BHMA A156.5.
 4. Dustproof Strikes: BHMA A156.16.

2.7 CONVENTIONAL EXIT DEVICES

- A. General Requirements: All exit devices specified herein shall meet or exceed the following criteria:
1. At doors not requiring a fire rating, provide devices complying with NFPA 101 and listed and labeled for "Panic Hardware" according to UL305. Provide proper fasteners as required by manufacturer including sex nuts and bolts at openings specified in the Hardware Sets.
 2. Where exit devices are required on fire rated doors, provide devices complying with NFPA 80 and with UL labeling indicating "Fire Exit Hardware". Provide devices with the proper fasteners for installation as tested and listed by UL. Consult manufacturer's catalog and template book for specific requirements.

Weedsport Addition to Maintenance Section and Roof Replacement, MP 304.2

3. Except on fire rated doors, provide exit devices with hex key dogging device to hold the pushbar and latch in a retracted position. Provide optional keyed cylinder dogging on devices where specified in Hardware Sets.
 4. Devices must fit flat against the door face with no gap that permits unauthorized dogging of the push bar. The addition of filler strips is required in any case where the door light extends behind the device as in a full glass configuration.
 5. Electromechanical Options: Subject to same compliance standards and requirements as mechanical exit devices, electrified devices to be of type and design as specified in hardware sets. Include any specific controllers when conventional power supplies are not sufficient to provide the proper inrush current.
 6. Lever Operating Trim: Where exit devices require lever trim, furnish manufacturer's heavy duty escutcheon trim with threaded studs for thru-bolts.
 - a. Lock Trim Design: As indicated in Hardware Sets, provide finishes and designs to match that of the specified locksets.
 - b. Where function of exit device requires a cylinder, provide a cylinder (Rim or Mortise) as specified in Hardware Sets.
 7. Vertical Rod Exit Devices: Where surface or concealed vertical rod exit devices are used at interior openings, provide as less bottom rod (LBR) unless otherwise indicated. Provide dust proof strikes where thermal pins are required to project into the floor.
 8. Narrow Stile Applications: At doors constructed with narrow stiles, or as specified in Hardware Sets, provide devices designed for maximum 2" wide stiles.
 9. Dummy Push Bar: Nonfunctioning push bar matching functional push bar.
 10. Extended cycle test: Devices to have been cycle tested in ordinance with ANSI/BHMA 156.2 requirements to 9 million cycles.
 11. Rail Sizing: Provide exit device rails factory sized for proper door width application.
 12. Through Bolt Installation: For exit devices and trim as indicated in Door Hardware Sets.
- B. Conventional Push Rail Exit Devices (Heavy Duty): ANSI/BHMA A156.3, Grade 1 certified panic and fire exit hardware devices furnished in the functions specified in the Hardware Sets. Exit device latch to be stainless steel, Pullman type, with deadlock feature.
1. Acceptable Manufacturers:
 - a. Stanley Precision (PR) - Apex 2000 Series.
 - b. Corbin Russwin Hardware (RU) - ED5000 Series.
 - c. Sargent Manufacturing (SA) - 80 Series.
- C. Extruded Aluminum Removable Mullions: ANSI/BHMA A156.3 anodized, removable mullions with malleable-iron top and bottom retainers. Mullions to be provided standard with stabilizers and imbedded weatherstrip.
1. Acceptable Manufacturers:
 - a. Corbin Russwin Hardware (RU) – 808 Series.
 - b. Sargent Manufacturing (SA) - 650A Series.

2.8 DOOR CLOSERS

- A. All door closers specified herein shall meet or exceed the following criteria:
1. General: Door closers to be from one manufacturer, matching in design and style, with the same type door preparations and templates regardless of application or spring size. Closers to be non-handed with full sized covers including installation and adjusting information on inside of cover.

Weedsport Addition to Maintenance Section and Roof Replacement, MP 304.2

2. Standards: Closers to comply with UL-10C for Positive Pressure Fire Test and be U.L. listed for use of fire rated doors.
 3. Cycle Testing: Provide closers which have surpassed 15 million cycles in a test witnessed and verified by UL.
 4. Size of Units: Comply with manufacturer's written recommendations for sizing of door closers depending on size of door, exposure to weather, and anticipated frequency of use. Where closers are indicated for doors required to be accessible to the physically handicapped, provide units complying with ANSI ICC/A117.1.
 5. Closer Arms: Provide heavy duty, forged steel closer arms unless otherwise indicated in Hardware Sets.
 6. Closers shall not be installed on exterior or corridor side of doors; where possible install closers on door for optimum aesthetics.
 7. Closer Accessories: Provide door closer accessories including custom templates, special mounting brackets, spacers and drop plates, and through-bolt and security type fasteners as required for proper installation.
- B. Door Closers, Surface Mounted (Large Body Cast Iron): ANSI/BHMA A156.4, Grade 1 surface mounted, heavy duty door closers with complete spring power adjustment, sizes 1 thru 6; and fully operational adjustable according to door size, frequency of use, and opening force. Closers to be rack and pinion type, one piece cast iron body construction, with adjustable backcheck and separate non-critical valves for closing sweep and latch speed control.
1. Acceptable Manufacturers:
 - a. Stanley D4550/D-4551 Series
 - b. LCN Closers (LC) - 4040XP Series.
 - c. Corbin Russwin (RU) – 6000 Series.
 - d. Sargent Manufacturing (SA) - 281 Series.

2.9 DOOR STOPS AND HOLDERS

- A. General: Door stops and holders to be of type and design as specified below or in the Hardware Sets.
- B. Door Stops and Bumpers: ANSI/BHMA A156.16, Grade 1 certified door stops and wall bumpers. Provide wall bumpers, either convex or concave types with anchorage as indicated, unless floor or other types of door stops are specified in Hardware Sets. Do not mount floor stops where they will impede traffic. Where floor or wall bumpers are not appropriate, provide overhead type stops and holders.
1. Acceptable Manufacturers:
 - a. Burns Manufacturing (BU).
 - b. Rockwood Manufacturing (RO).
 - c. Trimco (TC).

2.10 ARCHITECTURAL SEALS

- A. General: Thresholds, weatherstripping, and gasket seals to be of type and design as specified below or in the Hardware Sets. Provide continuous weatherstrip gasketing on exterior doors and provide smoke, light, or sound gasketing on interior doors where indicated. At exterior applications provide non-corrosive fasteners and elsewhere where indicated.

Weedsport Addition to Maintenance Section and Roof Replacement, MP 304.2

- B. Smoke Labeled Gasketing: Assemblies complying with NFPA 105 that are listed and labeled by a testing and inspecting agency acceptable to authorities having jurisdiction, for smoke control ratings indicated, based on testing according to UL 1784.
 - 1. Provide smoke labeled perimeter gasketing at all smoke labeled openings.
- C. Fire Labeled Gasketing: Assemblies complying with NFPA 80 that are listed and labeled by a testing and inspecting agency acceptable to authorities having jurisdiction, for fire ratings indicated, based on testing according to UL-10C.
 - 1. Provide intumescent seals as indicated to meet UL10C Standard for Positive Pressure Fire Tests of Door Assemblies, and UBC 7-2, Fire Tests of Door Assemblies.
- D. Sound-Rated Gasketing: Assemblies that are listed and labeled by a testing and inspecting agency, for sound ratings indicated.
- E. Replaceable Seal Strips: Provide only those units where resilient or flexible seal strips are easily replaceable and readily available from stocks maintained by manufacturer.
- F. Acceptable Manufacturers:
 - 1. National Guard Products (NG).
 - 2. Pemko Manufacturing (PE).
 - 3. Reese Enterprises, Inc. (RE).

2.11 FABRICATION

- A. Fasteners: Provide door hardware manufactured to comply with published templates generally prepared for machine, wood, and sheet metal screws. Provide screws according to manufacturers recognized installation standards for application intended.

2.12 FINISHES

- A. Standard: Designations used in the Hardware Sets and elsewhere indicate hardware finishes complying with ANSI/BHMA A156.18, including coordination with traditional U.S. finishes indicated by certain manufacturers for their products.
- B. Provide quality of finish, including thickness of plating or coating (if any), composition, hardness, and other qualities complying with manufacturer's standards, but in no case less than specified by referenced standards for the applicable units of hardware.
- C. Protect mechanical finishes on exposed surfaces from damage by applying a strippable, temporary protective covering before shipping.

PART 3 - EXECUTION**3.1 EXAMINATION**

- A. Examine scheduled openings, with Installer present, for compliance with requirements for installation tolerances, labeled fire door assembly construction, wall and floor construction, and other conditions affecting performance.

Weedsport Addition to Maintenance Section and Roof Replacement, MP 304.2

- B. Notify architect of any discrepancies or conflicts between the door schedule, door types, drawings and scheduled hardware. Proceed only after such discrepancies or conflicts have been resolved in writing.

3.2 PREPARATION

- A. Hollow Metal Doors and Frames: Comply with ANSI/DHI A115 series.
- B. Wood Doors: Comply with ANSI/DHI A115-W series.

3.3 INSTALLATION

- A. Install each item of mechanical and electromechanical hardware and access control equipment to comply with manufacturer's written instructions and according to specifications.
 - 1. Installers are to be trained and certified by the manufacturer on the proper installation and adjustment of fire, life safety, and security products including: hanging devices; locking devices; closing devices; and seals.
- B. Mounting Heights: Mount door hardware units at heights indicated in following applicable publications, unless specifically indicated or required to comply with governing regulations:
 - 1. Standard Steel Doors and Frames: DHI's "Recommended Locations for Architectural Hardware for Standard Steel Doors and Frames."
 - 2. Wood Doors: DHI WDHS.3, "Recommended Locations for Architectural Hardware for Wood Flush Doors."
 - 3. Where indicated to comply with accessibility requirements, comply with ANSI A117.1 "Accessibility Guidelines for Buildings and Facilities."
 - 4. Provide blocking in drywall partitions where wall stops or other wall mounted hardware is located.
- C. Retrofitting: Install door hardware to comply with manufacturer's published templates and written instructions. Where cutting and fitting are required to install door hardware onto or into surfaces that are later to be painted or finished in another way, coordinate removal, storage, and reinstallation of surface protective trim units with finishing work specified in Division 9 Sections. Do not install surface-mounted items until finishes have been completed on substrates involved.
- D. Thresholds: Set thresholds for exterior and acoustical doors in full bed of sealant complying with requirements specified in Division 7 Section "Joint Sealants."
- E. Storage: Provide a secure lock up for hardware delivered to the project but not yet installed. Control the handling and installation of hardware items so that the completion of the work will not be delayed by hardware losses before and after installation.

3.4 FIELD QUALITY CONTROL

- A. Field Inspection: Supplier will perform a final inspection of installed door hardware and state in report whether work complies with or deviates from requirements, including whether door hardware is properly installed, operating and adjusted.

3.5 ADJUSTING

- A. Initial Adjustment: Adjust and check each operating item of door hardware and each door to ensure proper operation or function of every unit. Replace units that cannot be adjusted to operate as intended. Adjust door control devices to compensate for final operation of heating and ventilating equipment and to comply with referenced accessibility requirements.

3.6 CLEANING AND PROTECTION

- A. Protect all hardware stored on construction site in a covered and dry place. Protect exposed hardware installed on doors during the construction phase. Install any and all hardware at the latest possible time frame.
- B. Clean adjacent surfaces soiled by door hardware installation.
- C. Clean operating items as necessary to restore proper finish. Provide final protection and maintain conditions that ensure door hardware is without damage or deterioration at time of owner occupancy.

3.7 DEMONSTRATION

- A. Instruct Owner's maintenance personnel to adjust, operate, and maintain mechanical and electromechanical door hardware.

3.8 DOOR HARDWARE SETS

- A. The hardware sets represent the design intent and direction of the owner and architect. They are a guideline only and should not be considered a detailed hardware schedule. Discrepancies, conflicting hardware and missing items should be brought to the attention of the architect with corrections made prior to the bidding process. Omitted items not included in a hardware set should be scheduled with the appropriate additional hardware required for proper application and functionality

Hardware Schedule**Set: 1**

3	Hinges	FBB 199 4 ½" x 4 ½" NRP	32D	Stanley
1	Closer	D-4550 HCS	689	Stanley
1	Exit Device	2108 X 4908A CD	626	Precision
1	Electric Strike	BES 0162	626	Best
1	Threshold	<u>253x3AFG Pemkote MSSES25SS</u>		Pemko

DOOR HARDWARE

087100-12

Weedsport Addition to Maintenance Section and Roof Replacement, MP 304.2

1	Gasketing	303CS		Pemko
1	Sweep	<u>3452CNB TKSP8</u>		Pemko

Set: 2

3	Hinges	FBB 179 4 ½" x 4 ½"	26D	Stanley
1	Classroom Lockset	9K3-7R15D S3	626	Best
1	Wall Stop	409	612	Rockwood
1	Closer	D-4550 H	689	Stanley

Set: 3

1	Continuous Hinge	FULL MORTISE, AL, GEARED	26D	Stanley
1	Passage Lockset	9K3-0N15D S3	626	Best
1	Closer	D-4550	689	Stanley
1	Wall Stop	409	612	Rockwood

END OF SECTION 087100

ITEM 627.0009 25**FINISHES****1. DESCRIPTION:**

- 1.01 Furnish all labor, materials, equipment and services necessary to complete the work as indicated on the Contract Plans and the attached Specification Summary.
- 1.02 All work shall conform to the requirements specified in Part 1 – General, of the Sections listed.

2. MATERIALS:

- 2.01 The materials shall be as specified in Part 2 – Products, of the Sections listed.

3. CONSTRUCTION DETAILS:

- 3.01 The construction details shall be as specified on Part 3 – Execution, if the Sections listed.

4. METHOD OF MEASUREMENT:

- 4.01 This item shall be measured for payment on a lump sum basis for the work completed in accordance with the Contract Documents and as directed by the Engineer.

5. BASIS OF PAYMENT:

- 5.01 Payment for this item shall be made at the lump sum bid price bid. The lump sum price bid shall include cost of furnishing all labor, material, equipment and appliances necessary to complete the work as indicated on the Contract Plans and as specified herein in the Sections listed.
- 5.02 Detailed Estimate:
 - A. Before the first certificate of payment is issued for the work under this item, submit a detailed estimate of quantities and prices for all materials, labor, and other items included under this item, which shall aggregate the contract lump sum price bid for this item. Prepare the detailed estimate in the same sequence as the Sections listed.
 - B. The detailed estimate shall be supported by such evidence, including certified copies of subcontracts, as the Engineer may require.
 - C. The detailed estimate must be approved by the Engineer who may revise it as, in his/her reasonable judgment, is necessary to make the various item conform to their true values. The value of each certificate of payment will be based on the approved detailed estimate.
- 5.03 Monthly payments will be made for this item in proportion to the total amount of work completed.

ITEM 627.0009 25**FINISHES****1. SPECIFICATION SUMMARY**

1.01 This Item includes the following specifications:

- A. Section 092216 NON-STRUCTURAL METAL FRAMING
- B. Section 092900 GYPSUM BOARD
- C. Section 093000 TILING
- D. Section 095113 ACOUSTICAL PANEL CEILINGS
- E. Section 096513 RESILIENT BASE AND ACCESSORIES
- F. Section 096519 RESILIENT TILE FLOORING
- G. Section 099113 EXTERIOR PAINTING
- H. Section 099123 INTERIOR PAINTING
- I. Section 099600 HIGH-PERFORMANCE COATINGS SPECIALTIES

1.02 This item shall include, but not be limited to, the following:

- A. Surface Preparation for Priming & Painting
- B. Paint Primer & Finish Coatings
- C. Acoustical Panel Ceilings and other Tiling

SECTION 092216 - NON-STRUCTURAL METAL FRAMING

PART 1 - GENERAL

1.1 SUMMARY

- A. Section Includes:
1. Non-load-bearing steel framing systems for interior gypsum board assemblies.
 2. Suspension systems for interior gypsum ceilings, soffits, and grid systems.

1.2 ACTION SUBMITTALS

- A. Product Data: For each type of product.

1.3 INFORMATIONAL SUBMITTALS

- A. Evaluation Reports: For dimpled steel studs and runners, firestop tracks, from ICC-ES.

PART 2 - PRODUCTS

2.1 PERFORMANCE REQUIREMENTS

- A. Fire-Test-Response Characteristics: For fire-resistance-rated assemblies that incorporate non-load-bearing steel framing, provide materials and construction identical to those tested in assembly indicated, according to ASTM E 119 by an independent testing agency.
- B. STC-Rated Assemblies: For STC-rated assemblies, provide materials and construction identical to those tested in assembly indicated, according to ASTM E 90 and classified according to ASTM E 413 by an independent testing agency.

2.2 FRAMING SYSTEMS

- A. Recycled Content of Steel Products: Postconsumer recycled content plus one-half of preconsumer recycled content not less than 25 percent.
- B. Framing Members, General: Comply with ASTM C 754 for conditions indicated.
1. Steel Sheet Components: Comply with ASTM C 645 requirements for metal unless otherwise indicated.
 2. Protective Coating: ASTM A 653/A 653M, G40, hot-dip galvanized unless otherwise indicated.
- C. Studs and Runners: ASTM C 645. Use either steel studs and runners or dimpled steel studs and runners.
1. Steel Studs and Runners:
 - a. Minimum Base-Metal Thickness: 0.0312 inch (30mil)
 - b. Depth: As indicated on Drawings.
 2. Dimpled Steel Studs and Runners:
 - a. Base-Metal Thickness and Yield Strength required to achieve structural performance equivalent to 30 mil, 33 KSI standard studs
 - b. Depth: As indicated on Drawings.

Weedsport Addition to Maintenance Section and Roof Replacement, MP 304.2

- D. Slip-Type Head Joints: Where indicated, provide one of the following:
1. Single Long-Leg Runner System: ASTM C 645 top runner with 2-inch deep flanges in thickness not less than indicated for studs, installed with studs friction fit into top runner and with continuous bridging located within 12 inches of the top of studs to provide lateral bracing.
 2. Double-Runner System: ASTM C 645 top runners, inside runner with 2-inch deep flanges in thickness not less than indicated for studs and fastened to studs, and outer runner sized to friction fit inside runner.
 3. Deflection Track: Steel sheet top runner manufactured to prevent cracking of finishes applied to interior partition framing resulting from deflection of structure above; in thickness not less than indicated for studs and in width to accommodate depth of studs.
- E. Firestop Tracks: Top runner manufactured to allow partition heads to expand and contract with movement of the structure while maintaining continuity of fire-resistance-rated assembly indicated; in thickness not less than indicated for studs and in width to accommodate depth of studs.
1. Products: Subject to compliance with requirements, available products that may be incorporated into the Work include, but are not limited to, the following:
 - a. Fire Trak Corp.; Fire Trak System attached to studs with Fire Trak Posi Klip.
 - b. Grace Construction Products; FlameSafe FlowTrak System.
 - c. Metal-Lite, Inc.; The System.
- F. Flat Strap and Backing Plate: Steel sheet for blocking and bracing in length and width indicated.
1. Minimum Base-Metal Thickness: 0.027 inch.
- G. Cold-Rolled Channel Bridging: Steel, 0.053-inch minimum base-metal thickness, with minimum 1/2-inch- wide flanges.
1. Depth: As indicated on Drawings.
 2. Clip Angle: Not less than 1-1/2 by 1-1/2 inches, 0.068-inch- thick, galvanized steel.
- H. Hat-Shaped, Rigid Furring Channels: ASTM C 645.
1. Minimum Base-Metal Thickness: 0.033 inch.
 2. Depth: As indicated on Drawings.
- I. Resilient Furring Channels: 1/2-inch- deep, steel sheet members designed to reduce sound transmission.
1. Configuration: Asymmetrical.
- J. Cold-Rolled Furring Channels: 0.053-inch uncoated-steel thickness, with minimum 1/2-inch wide flanges.
1. Depth: As indicated on Drawings.
 2. Furring Brackets: Adjustable, corrugated-edge type of steel sheet with minimum uncoated-steel thickness of 0.033 inch.
 3. Tie Wire: ASTM A 641/A 641M, Class 1 zinc coating, soft temper, 0.062-inch- diameter wire, or double strand of 0.048-inch- diameter wire.
- K. Z-Shaped Furring: With slotted or nonslotted web, face flange of 1-1/4 inches, wall attachment flange of 7/8 inch, minimum uncoated-metal thickness of 0.018 inch, and depth required to fit insulation thickness indicated.
- L. Partial Wall Framing Connection: Connector designed to support out-of-plane loading of cantilevered partial wall systems that are unsupported at the top track.
1. Basis-of-Design Product: Subject to compliance with requirements, provide ClarkDietrich Pony Wall PW36 or comparable product by a current member of the SFIA.

Weedsport Addition to Maintenance Section and Roof Replacement, MP 304.2

- a. Minimum Base-Steel Thickness: 0.0966 inch (2.45 mm).

2.3 SUSPENSION SYSTEMS

- A. Tie Wire: ASTM A 641/A 641M, Class 1 zinc coating, soft temper, 0.062-inch- diameter wire, or double strand of 0.048-inch- diameter wire.
- B. Hanger Attachments to Concrete:
 - 1. Anchors: Fabricated from corrosion-resistant materials with holes or loops for attaching wire hangers and capable of sustaining, without failure, a load equal to 5 times that imposed by construction as determined by testing according to ASTM E 488 by an independent testing agency.
 - a. Type: Postinstalled, expansion anchor.
 - 2. Powder-Actuated Fasteners: Suitable for application indicated, fabricated from corrosion-resistant materials with clips or other devices for attaching hangers of type indicated, and capable of sustaining, without failure, a load equal to 10 times that imposed by construction as determined by testing according to ASTM E 1190 by an independent testing agency.
- C. Wire Hangers: ASTM A 641/A 641M, Class 1 zinc coating, soft temper, 0.16 inch in diameter.
- D. Carrying Channels: Cold-rolled, commercial-steel sheet with a base-metal thickness of 0.053 inch and minimum 1/2-inch- wide flanges.
 - 1. Depth: 2 inches.
- E. Grid Suspension System for Gypsum Board Ceilings: ASTM C 645, direct-hung system composed of main beams and cross-furring members that interlock.
 - 1. Products: Subject to compliance with requirements, available products that may be incorporated into the Work include, but are not limited to, the following:
 - a. Armstrong World Industries, Inc.; Drywall Grid Systems.
 - b. Chicago Metallic Corporation; Drywall Grid System.
 - c. USG Corporation; Drywall Suspension System.

2.4 AUXILIARY MATERIALS

- A. General: Provide auxiliary materials that comply with referenced installation standards.
 - 1. Fasteners for Metal Framing: Of type, material, size, corrosion resistance, holding power, and other properties required to fasten steel members to substrates.
- B. Isolation Strip at Exterior Walls: Provide one of the following:
 - 1. Asphalt-Saturated Organic Felt: ASTM D 226, Type I (No. 15 asphalt felt), nonperforated.
 - 2. Foam Gasket: Adhesive-backed, closed-cell vinyl foam strips that allow fastener penetration without foam displacement, 1/8 inch thick, in width to suit steel stud size.

PART 3 - EXECUTION**3.1 EXAMINATION**

- A. Examine areas and substrates, with Installer present, and including welded hollow-metal frames, cast-in anchors, and structural framing, for compliance with requirements and other conditions affecting performance of the Work.
- B. Proceed with installation only after unsatisfactory conditions have been corrected.

Weedsport Addition to Maintenance Section and Roof Replacement, MP 304.2

3.2 PREPARATION

- A. Suspended Assemblies: Coordinate installation of suspension systems with installation of overhead structure to ensure that inserts and other provisions for anchorages to building structure have been installed to receive hangers at spacing required to support the Work and that hangers will develop their full strength.
 - 1. Furnish concrete inserts and other devices indicated to other trades for installation in advance of time needed for coordination and construction.
- B. Coordination with Sprayed Fire-Resistive Materials:
 - 1. Before sprayed fire-resistive materials are applied, attach offset anchor plates or ceiling runners (tracks) to surfaces indicated to receive sprayed fire-resistive materials. Where offset anchor plates are required, provide continuous plates fastened to building structure not more than 24 inches o.c.
 - 2. After sprayed fire-resistive materials are applied, remove them only to extent necessary for installation of non-load-bearing steel framing. Do not reduce thickness of fire-resistive materials below that required for fire-resistance ratings indicated. Protect adjacent fire-resistive materials from damage.

3.3 INSTALLATION, GENERAL

- A. Installation Standard: ASTM C 754.
 - 1. Gypsum Board Assemblies: Also comply with requirements in ASTM C 840 that apply to framing installation.
- B. Install supplementary framing, and blocking to support fixtures, equipment services, heavy trim, grab bars, toilet accessories, furnishings, or similar construction.
- C. Install bracing at terminations in assemblies.
- D. Do not bridge building control and expansion joints with non-load-bearing steel framing members. Frame both sides of joints independently.

3.4 INSTALLING FRAMED ASSEMBLIES

- A. Install framing system components according to spacings indicated, but not greater than spacings required by referenced installation standards for assembly types.
 - 1. Single-Layer Application: 16 inches o.c. unless otherwise indicated.
 - 2. Multilayer Application: 16 inches o.c. unless otherwise indicated.
 - 3. Tile Backing Panels: 16 inches o.c. unless otherwise indicated.
- B. Where studs are installed directly against exterior masonry walls or dissimilar metals at exterior walls, install isolation strip between studs and exterior wall.
- C. Install studs so flanges within framing system point in same direction.
- D. Install tracks (runners) at floors and overhead supports. Extend framing full height to structural supports or substrates above suspended ceilings except where partitions are indicated to terminate at suspended ceilings. Continue framing around ducts penetrating partitions above ceiling.
 - 1. Slip-Type Head Joints: Where framing extends to overhead structural supports, install to produce joints at tops of framing systems that prevent axial loading of finished assemblies.
 - 2. Door Openings: Screw vertical studs at jambs to jamb anchor clips on door frames; install runner track section (for cripple studs) at head and secure to jamb studs.
 - a. Install two studs at each jamb unless otherwise indicated.

Weedsport Addition to Maintenance Section and Roof Replacement, MP 304.2

- b. Install cripple studs at head adjacent to each jamb stud, with a minimum 1/2-inch clearance from jamb stud to allow for installation of control joint in finished assembly.
- c. Extend jamb studs through suspended ceilings and attach to underside of overhead structure.
- 3. Other Framed Openings: Frame openings other than door openings the same as required for door openings unless otherwise indicated. Install framing below sills of openings to match framing required above door heads.
- 4. Fire-Resistance-Rated Partitions: Install framing to comply with fire-resistance-rated assembly indicated and support closures and to make partitions continuous from floor to underside of solid structure.
 - a. Firestop Track: Install to maintain continuity of fire-resistance-rated assembly indicated.
- 5. Sound-Rated Partitions: Install framing to comply with sound-rated assembly indicated.
- 6. Curved Partitions:
 - a. Bend track to uniform curve and locate straight lengths so they are tangent to arcs.
 - b. Begin and end each arc with a stud, and space intermediate studs equally along arcs. On straight lengths of no fewer than two studs at ends of arcs, place studs 6 inches o.c.

3.5 INSTALLING SUSPENSION SYSTEMS

- A. Install suspension system components according to spacings indicated, but not greater than spacings required by referenced installation standards for assembly types.
 - 1. Hangers: 48 inches o.c.
 - 2. Carrying Channels (Main Runners): 48 inches o.c.
- B. Isolate suspension systems from building structure where they abut or are penetrated by building structure to prevent transfer of loading imposed by structural movement.
- C. Suspend hangers from building structure as follows:
 - 1. Install hangers plumb and free from contact with insulation or other objects within ceiling plenum that are not part of supporting structural or suspension system.
 - a. Splay hangers only where required to miss obstructions and offset resulting horizontal forces by bracing, countersplaying, or other equally effective means.
 - 2. Where width of ducts and other construction within ceiling plenum produces hanger spacings that interfere with locations of hangers required to support standard suspension system members, install supplemental suspension members and hangers in the form of trapezes or equivalent devices.
 - a. Size supplemental suspension members and hangers to support ceiling loads within performance limits established by referenced installation standards
 - 3. Wire Hangers: Secure by looping and wire tying, either directly to structures or to inserts, eye screws, or other devices and fasteners that are secure and appropriate for substrate, and in a manner that will not cause hangers to deteriorate or otherwise fail.
 - 4. Do not attach hangers to steel roof deck.
 - 5. Do not attach hangers to permanent metal forms. Furnish cast-in-place hanger inserts that extend through forms.
 - 6. Do not attach hangers to rolled-in hanger tabs of composite steel floor deck.
 - 7. Do not connect or suspend steel framing from ducts, pipes, or conduit.

Weedsport Addition to Maintenance Section and Roof Replacement, MP 304.2

- D. Fire-Resistance-Rated Assemblies: Wire tie furring channels to supports.
- E. Seismic Bracing: Sway-brace suspension systems with hangers used for support.
- F. Grid Suspension Systems: Attach perimeter wall track or angle where grid suspension systems meet vertical surfaces. Mechanically join main beam and cross-furring members to each other and butt-cut to fit into wall track.
- G. Installation Tolerances: Install suspension systems that are level to within 1/8 inch in 12 feet measured lengthwise on each member that will receive finishes and transversely between parallel members that will receive finishes.

END OF SECTION 092216

SECTION 092900 - GYPSUM BOARD

PART 1 - GENERAL

1.1 SUMMARY

- A. Section Includes:
 - 1. Interior gypsum board.
 - 2. Tile backing panels.
 - 3. Partition Closures
 - 4. Identifying and labeling of partitions.
- B. Related Requirements:
 - 1. Section 092216 "Non-Structural Metal Framing" for non-structural framing and suspension systems that support gypsum board panels.
 - 2. Section 093000 "Tiling" for cementitious backer units installed as substrates for ceramic tile.

1.2 ACTION SUBMITTALS

- A. Product Data: For each type of product.
- B. Samples: For the following products:
 - 1. Trim Accessories: Full-size Sample in 12-inch- long length for each trim accessory indicated.

1.3 QUALITY ASSURANCE

- A. Mockups: Before beginning gypsum board installation, install mockups of at least 100 sq. ft. in surface area to demonstrate aesthetic effects and set quality standards for materials and execution.
 - 1. Install mockups for the following:
 - a. Each level of gypsum board finish indicated for use in exposed locations.
 - 2. Apply or install final decoration indicated, including painting and wall coverings, on exposed surfaces for review of mockups.
 - 3. Simulate finished lighting conditions for review of mockups.
 - 4. Subject to compliance with requirements, approved mockups may become part of the completed Work if undisturbed at time of Substantial Completion.

1.4 DELIVERY, STORAGE AND HANDLING

- A. Store materials inside under cover and keep them dry and protected against weather, condensation, direct sunlight, construction traffic, and other potential causes of damage. Stack panels flat and supported on risers on a flat platform to prevent sagging.

Weedsport Addition to Maintenance Section and Roof Replacement, MP 304.2

1.5 FIELD CONDITIONS

- A. Environmental Limitations: Comply with ASTM C 840 requirements or gypsum board manufacturer's written recommendations, whichever are more stringent.
- B. Do not install paper-faced gypsum panels until installation areas are enclosed and conditioned.
- C. Do not install panels that are wet, those that are moisture damaged, and those that are mold damaged.
 - 1. Indications that panels are wet or moisture damaged include, but are not limited to, discoloration, sagging, or irregular shape.
 - 2. Indications that panels are mold damaged include, but are not limited to, fuzzy or splotchy surface contamination and discoloration.

PART 2 - PRODUCTS**2.1 PERFORMANCE REQUIREMENTS**

- A. Fire-Resistance-Rated Assemblies: For fire-resistance-rated assemblies, provide materials and construction identical to those tested in assembly indicated according to ASTM E 119 by an independent testing agency.
- B. STC-Rated Assemblies: For STC-rated assemblies, provide materials and construction identical to those tested in assembly indicated according to ASTM E 90 and classified according to ASTM E 413 by an independent testing agency.
- C. Low-Emitting Materials: For ceiling and wall assemblies, provide materials and construction identical to those tested in assembly and complying with the testing and product requirements of the California Department of Health Services' "Standard Practice for the Testing of Volatile Organic Emissions from Various Sources Using Small-Scale Environmental Chambers."

2.2 GYPSUM BOARD, GENERAL

- A. Recycled Content of Gypsum Panel Products: Postconsumer recycled content plus one-half of preconsumer recycled content not less than 60 percent.
- B. Regional Materials: Gypsum panel products shall be manufactured within 500 miles of Project site.
- C. Size: Provide maximum lengths and widths available that will minimize joints in each area and that correspond with support system indicated.

2.3 INTERIOR GYPSUM BOARD

- A. Manufacturers: Subject to compliance with requirements, provide products by the following:
 - 1. Georgia-Pacific Gypsum LLC.
 - 2. National Gypsum Company.
 - 3. USG Corporation.
- B. Hi Abuse Moisture and mold resistant Gypsum Board: ASTM C 1396.
 - 1. Basis of Design Product: Gold Bond® Hi-Abuse XP Gypsum Panel
 - 2. Core: 5/8-inch, Type X.
 - 3. Long Edges: Tapered.
 - 4. Mold Resistance: ASTM D 3273, score of 10 as rated according to ASTM D 3274.

Weedsport Addition to Maintenance Section and Roof Replacement, MP 304.2

2.4 TILE BACKING PANELS

- A. Cementitious Backer Units: ANSI A118.9 and ASTM C 1288 or 1325, with manufacturer's standard edges.
1. Products: Subject to compliance with requirements, available products that may be incorporated into the Work include, but are not limited to, the following:
 - a. CertainTeed Corp.; FiberCement BackerBoard.
 - b. James Hardie Building Products, Inc.; Hardiebacker.
 - c. National Gypsum Company, Permabase Cement Board.
 - d. USG Corporation; DUROCK Cement Board.
 2. Thickness: 5/8 inch.
 3. Mold Resistance: ASTM D 3273, score of 10 as rated according to ASTM D 3274.

2.5 TRIM ACCESSORIES

- A. Interior Trim: ASTM C 1047.
1. Material: Galvanized or aluminum-coated steel sheet or rolled zinc.
 2. Shapes:
 - a. Cornerbead.
 - b. LC-Bead: J-shaped; exposed long flange receives joint compound.
 - c. Expansion (Control) Joint: One-piece, rolled zinc with V-shaped slot and removable strip covering slot opening.
- B. Interior Reveals
1. Manufacturer: Fry Reglet
 2. Product: Snap-in Reveal DRM-Snap-in-375 - 3/8" reveal
 3. Description: A 6063 Aluminum reveal fastened to gypsum board with joint treatment compound finish with snap in finish reveal trim.
 4. Provide in locations as indicated on the drawings.

2.6 JOINT TREATMENT MATERIALS

- A. General: Comply with ASTM C 475/C 475M.
- B. Joint Tape:
1. Interior Gypsum Board: Paper.
 2. Tile Backing Panels: As recommended by panel manufacturer.
- C. Joint Compound for Interior Gypsum Board: For each coat use formulation that is compatible with other compounds applied on previous or for successive coats.
1. Prefilling: At open joints, rounded or beveled panel edges, and damaged surface areas, use setting-type taping compound.
 2. Embedding and First Coat: For embedding tape and first coat on joints, fasteners, and trim flanges, use setting-type taping or drying-type, all-purpose compound.
 3. Fill Coat: For second coat, use setting-type, sandable topping or drying-type, all-purpose compound.
 4. Finish Coat: For third coat, use drying-type, all-purpose compound.

Weedsport Addition to Maintenance Section and Roof Replacement, MP 304.2

5. Skim Coat: For final coat of Level 5 finish, use drying-type, all-purpose compound or high-build interior coating product designed for application by airless sprayer and to be used instead of skim coat to produce Level 5 finish.
- D. Joint Compound for Tile Backing Panels:
1. Cementitious Backer Units: As recommended by backer unit manufacturer.

2.7 AUXILIARY MATERIALS

- A. General: Provide auxiliary materials that comply with referenced installation standards and manufacturer's written recommendations.
- B. Steel Drill Screws: ASTM C 1002, unless otherwise indicated.
1. Use screws complying with ASTM C 954 for fastening panels to steel members from 0.033 to 0.112 inch thick.
 2. For fastening cementitious backer units, use screws of type and size recommended by panel manufacturer.
- C. Acoustical Joint Sealant: Manufacturer's standard nonsag, paintable, nonstaining latex sealant complying with ASTM C 834. Product effectively reduces airborne sound transmission through perimeter joints and openings in building construction as demonstrated by testing representative assemblies according to ASTM E 90.
1. Products: Subject to compliance with requirements, provide the following:
 - a. Pecora Corporation; AC-20 FTR.
- D. Thermal Insulation: As specified in Section 072100 "Thermal Insulation."

PART 3 - EXECUTION**3.1 EXAMINATION**

- A. Examine areas and substrates including welded hollow-metal frames and framing, with Installer present, for compliance with requirements and other conditions affecting performance.
- B. Examine panels before installation. Reject panels that are wet, moisture damaged, and mold damaged.
- C. Proceed with installation only after unsatisfactory conditions have been corrected.

3.2 APPLYING AND FINISHING PANELS, GENERAL

- A. Comply with ASTM C 840.
- B. Install ceiling panels across framing to minimize the number of abutting end joints and to avoid abutting end joints in central area of each ceiling. Stagger abutting end joints of adjacent panels not less than one framing member.
- C. Install panels with face side out. Butt panels together for a light contact at edges and ends with not more than 1/16 inch of open space between panels. Do not force into place.
- D. Locate edge and end joints over supports, except in ceiling applications where intermediate supports or gypsum board back-blocking is provided behind end joints. Do not place tapered

Weedsport Addition to Maintenance Section and Roof Replacement, MP 304.2

edges against cut edges or ends. Stagger vertical joints on opposite sides of partitions. Do not make joints other than control joints at corners of framed openings.

- E. Cover both faces of support framing with gypsum panels in concealed spaces (above ceilings, etc.), except in chases braced internally.
 - 1. Fit gypsum panels around ducts, pipes, and conduits.
 - 2. Where partitions intersect, structural members projecting below underside of floor/roof slabs and decks, cut gypsum panels to fit profile formed by structural members; allow 1/4- to 3/8-inch- wide joints to install sealant.
- F. Isolate perimeter of gypsum board applied to non-load-bearing partitions at structural abutments, except floors. Provide 1/4- to 1/2-inch- wide spaces at these locations and trim edges with edge trim where edges of panels are exposed. Seal joints between edges and abutting structural surfaces with acoustical sealant.
- G. Attachment to Steel Framing: Attach panels so leading edge or end of each panel is attached to open (unsupported) edges of stud flanges first.
- H. STC-Rated Assemblies: Seal construction at perimeters, behind control joints, and at openings and penetrations with a continuous bead of acoustical sealant. Install acoustical sealant at both faces of partitions at perimeters and through penetrations. Comply with ASTM C 919 and with manufacturer's written recommendations for locating edge trim and closing off sound-flanking paths around or through assemblies, including sealing partitions above acoustical ceilings.
- I. Install sound attenuation blankets before installing gypsum panels unless blankets are readily installed after panels have been installed on one side.

3.3 APPLYING INTERIOR GYPSUM BOARD

- A. Single-Layer Application:
 - 1. On ceilings, apply gypsum panels before wall/partition board application to greatest extent possible and at right angles to framing unless otherwise indicated.
 - 2. On partitions/walls, apply gypsum panels vertically (parallel to framing) unless otherwise indicated or required by fire-resistance-rated assembly, and minimize end joints.
 - a. Stagger abutting end joints not less than one framing member in alternate courses of panels.
 - b. At stairwells and other high walls, install panels horizontally unless otherwise indicated or required by fire-resistance-rated assembly.
 - 3. Fastening Methods: Apply gypsum panels to supports with steel drill screws.

3.4 APPLYING TILE BACKING PANELS

- A. Cementitious Backer Units: ANSI A108.11, at locations indicated to receive tile.

3.5 INSTALLING TRIM ACCESSORIES

- A. General: For trim with back flanges intended for fasteners, attach to framing with same fasteners used for panels. Otherwise, attach trim according to manufacturer's written instructions.

Weedsport Addition to Maintenance Section and Roof Replacement, MP 304.2

- B. Control Joints: Install control joints according to ASTM C 840 and in specific locations approved by Architect for visual effect. Locate Control Joint over door head as indicated on the drawings at a maximum spacing of 30'.
- C. Interior Trim: Install in the following locations:
 - 1. Cornerbead: Use at outside corners unless otherwise indicated.
 - 2. LC-Bead: Use at exposed panel edges.

3.6 PARTITION CLOSURE INSTALLATION

- A. Prepare Joint in accordance with manufacturers installation instructions.
- B. Cut the material lengthwise to fit the opening. Add 1/2" to the length.
- C. Insert the joint material into the closure opening by applying hand pressure. Use a plastic trowel to adjust the final position. Finished position should be slightly recessed from the wall.

3.7 FINISHING GYPSUM BOARD

- A. General: Treat gypsum board joints, interior angles, edge trim, control joints, penetrations, fastener heads, surface defects, and elsewhere as required to prepare gypsum board surfaces for decoration. Promptly remove residual joint compound from adjacent surfaces.
- B. Apply joint tape over gypsum board joints, except for trim products specifically indicated as not intended to receive tape.
- C. Gypsum Board Finish Levels: Finish panels to levels indicated below and according to ASTM C 840:
 - 1. Level 1: Ceiling plenum areas, concealed areas, and where indicated.
 - 2. Level 2: Panels that are substrate for tile.
 - 3. Level 4: At panel surfaces that will be exposed to view unless otherwise indicated.
- D. Cementitious Backer Units: Finish according to manufacturer's written instructions.

3.8 FIRE AND SMOKE BARRIER IDENTIFICATION

- A. Mark wall above ceiling every 8 feet maximum, once per wall section minimum, with its fire and/or smoke barrier designation.
 - 1. Designations to be marked clearly using die-cut mylar stencils.
 - 2. Characters to be 4" minimum in height of a legible font type.
 - 3. Characters to be marked with bright red spray paint
 - a. Character Designations:
 - 1) One hour fire barrier
 - a) 1FB
 - 2) Two hour fire barrier
 - a) 2FB
 - 3) One hour smoke barrier
 - a) 1SB
 - 4) One hour fire/smoke barrier
 - a) 1FSB
 - 5) Two hour fire/smoke barrier
 - a) 2FSB

Weedsport Addition to Maintenance Section and Roof Replacement, MP 304.2

- 6) Smoke Tight Partitions
 - a) ST

3.9 PROTECTION

- A. Protect adjacent surfaces from drywall compound and promptly remove from floors and other non-drywall surfaces. Repair surfaces stained, marred, or otherwise damaged during drywall application.
- B. Protect installed products from damage from weather, condensation, direct sunlight, construction, and other causes during remainder of the construction period.
- C. Remove and replace panels that are wet, moisture damaged, and mold damaged.
 - 1. Indications that panels are wet or moisture damaged include, but are not limited to, discoloration, sagging, or irregular shape.
 - 2. Indications that panels are mold damaged include, but are not limited to, fuzzy or splotchy surface contamination and discoloration.

END OF SECTION 092900

SECTION 093000 - TILING

PART 1 - GENERAL

1.1 SUMMARY

A. Section Includes:

1. Ceramic tile.
2. Stone thresholds.
3. Waterproof membrane.
4. Crack isolation membrane.
5. Metal edge strips.

B. Related Sections:

1. Section 079200 "Joint Sealants" for sealing of expansion, contraction, control, and isolation joints in tile surfaces.
2. Section 092900 "Gypsum Board" for cementitious backer units.

1.2 DEFINITIONS

- A. General: Definitions in the ANSI A108 series of tile installation standards and in ANSI A137.1 apply to Work of this Section unless otherwise specified.
- B. ANSI A108 Series: ANSI A108.01, ANSI A108.02, ANSI A108.1A, ANSI A108.1B, ANSI A108.1C, ANSI A108.4, ANSI A108.5, ANSI A108.6, ANSI A108.8, ANSI A108.9, ANSI A108.10, ANSI A108.11, ANSI A108.12, ANSI A108.13, ANSI A108.14, ANSI A108.15, ANSI A108.16, and ANSI A108.17, which are contained in "American National Standard Specifications for Installation of Ceramic Tile."
- C. Module Size: Actual tile size plus joint width indicated.
- D. Face Size: Actual tile size, excluding spacer lugs.

1.3 PERFORMANCE REQUIREMENTS

- A. Static Coefficient of Friction: For tile installed on walkway surfaces, provide products with the following values as determined by testing identical products per ASTM C 1028:
1. Level Surfaces: Minimum 0.42.

1.4 ACTION SUBMITTALS

- A. Product Data: For each type of product indicated.
- B. Shop Drawings: Show locations of each type of tile and tile pattern. Show widths, details, and locations of expansion, contraction, control, and isolation joints in tile substrates and finished tile surfaces.
- C. Samples for Verification:
1. Full-size units of each type and composition of tile and for each color and finish required. For ceramic mosaic tile in color blend patterns, provide full sheets of each color blend.
 2. Stone thresholds in 6-inch lengths.

Weedsport Addition to Maintenance Section and Roof Replacement, MP 304.2

3. Metal edge strips in 6-inch lengths.

1.5 INFORMATIONAL SUBMITTALS

- A. Qualification Data: For qualified Installer.
- B. Master Grade Certificates: For each shipment, type, and composition of tile, signed by tile manufacturer and Installer.
- C. Product Certificates: For each type of product, signed by product manufacturer.
- D. Material Test Reports: For each tile-setting and -grouting product.

1.6 MAINTENANCE MATERIAL SUBMITTALS

- A. Furnish extra materials that match and are from same production runs as products installed and that are packaged with protective covering for storage and identified with labels describing contents.
 1. Tile and Trim Units: Furnish quantity of full-size units equal to 3 percent of amount installed for each type, composition, color, pattern, and size indicated.
 2. Grout: Furnish quantity of grout equal to 3 percent of amount installed for each type, composition, and color indicated.

1.7 QUALITY ASSURANCE

- A. Source Limitations for Tile: Obtain tile of each type and color or finish from one source or producer.
 1. Obtain tile of each type and color or finish from same production run and of consistent quality in appearance and physical properties for each contiguous area.
- B. Source Limitations for Setting and Grouting Materials: Obtain ingredients of a uniform quality for each mortar, adhesive, and grout component from one manufacturer and each aggregate from one source or producer.
- C. Source Limitations for Other Products: Obtain each of the following products specified in this Section from a single manufacturer for each product:
 1. Stone thresholds.
 2. Waterproof membrane.
 3. Crack isolation membrane.
 4. Joint sealants.
 5. Cementitious backer units.
 6. Metal edge strips.

1.8 DELIVERY, STORAGE, AND HANDLING

- A. Deliver and store packaged materials in original containers with seals unbroken and labels intact until time of use. Comply with requirements in ANSI A137.1 for labeling tile packages.
- B. Store tile and cementitious materials on elevated platforms, under cover, and in a dry location.
- C. Store aggregates where grading and other required characteristics can be maintained and contamination can be avoided.

Weedsport Addition to Maintenance Section and Roof Replacement, MP 304.2

- D. Store liquid materials in unopened containers and protected from freezing.
- E. Handle tile that has temporary protective coating on exposed surfaces to prevent coated surfaces from contacting backs or edges of other units. If coating does contact bonding surfaces of tile, remove coating from bonding surfaces before setting tile.

1.9 PROJECT CONDITIONS

- A. Environmental Limitations: Do not install tile until construction in spaces is complete and ambient temperature and humidity conditions are maintained at the levels indicated in referenced standards and manufacturer's written instructions.

PART 2 - PRODUCTS**2.1 PRODUCTS, GENERAL**

- A. ANSI Ceramic Tile Standard: Provide tile that complies with ANSI A137.1 for types, compositions, and other characteristics indicated.
 - 1. Provide tile complying with Standard grade requirements unless otherwise indicated.
- B. ANSI Standards for Tile Installation Materials: Provide materials complying with ANSI A108.02, ANSI standards referenced in other Part 2 articles, ANSI standards referenced by TCA installation methods specified in tile installation schedules, and other requirements specified.
- C. Factory Blending: For tile exhibiting color variations within ranges, blend tile in factory and package so tile units taken from one package show same range in colors as those taken from other packages and match approved Samples.
- D. Mounting: For factory-mounted tile, provide back- or edge-mounted tile assemblies as standard with manufacturer unless otherwise indicated.

2.2 TILE PRODUCTS

- A. Products: Refer to Color and Finish Schedule on Drawings I-250 for Manufacturer, Product, and Finish.
- B. Colors and Patterns: As indicated by manufacturer's designations.
- A. Ceramic Floor Tile: Unglazed porcelain tile.
 - 1. **Basis** of Design: Crossville Inc. **COLOR BLOX** Series
 - 2. Certification: Tile certified by the Porcelain Tile Certification Agency.
 - 3. Face Size: 11-13/16 by 11-13/16 inches (300 by 300 mm).
 - 4. Size of wall base: nominal 12' x 4" high bullnose trim.
 - 5. Face Size Variation: Rectified.
 - 6. Thickness: 3/8 inch (9.5 mm).
 - 7. Face: Plain with square or cushion edges.
 - 8. Dynamic Coefficient of Friction: Not less than 0.42.
 - 9. Tile Color, Glaze, and Pattern: As selected by Architect from manufacturer's full range.
 - 10. Grout Color: As selected by Architect from manufacturer's full range.
- A. Ceramic Wall Tile Type: Unglazed porcelain tile.

Weedsport Addition to Maintenance Section and Roof Replacement, MP 304.2

1. **Basis** of Design: Crossville Inc. **COLOR BLOX** Series
2. Certification: Tile certified by the Porcelain Tile Certification Agency.
3. Face Size: 6 by 6 inches (152 by 152 mm).
4. Face Size Variation: Rectified.
5. Thickness: 3/8 inch (9.5 mm).
6. Face: Plain with square or cushion edges.
7. Dynamic Coefficient of Friction: Not less than 0.42.
8. Tile Color, Glaze, and Pattern: As selected by Architect from manufacturer's full range.
9. Grout Color: As selected by Architect from manufacturer's full range.

2.3 THRESHOLDS

- A. General: Fabricate to sizes and profiles indicated or required to provide transition between adjacent floor finishes.
 1. Bevel edges at 1:2 slope, with lower edge of bevel aligned with or up to 1/16 inch above adjacent floor surface. Finish bevel to match top surface of threshold. Limit height of threshold to 1/2 inch or less above adjacent floor surface.
- B. Marble Thresholds: ASTM C 503, with a minimum abrasion resistance of 10 per ASTM C 1353 or ASTM C 241 and with honed finish.
 1. Description: Uniform, fine- to medium-grained white stone with gray veining.
 2. Description: Match Architect's sample.

2.4 ACCESSORY TRIMS

- A. Metal Edge and Trim Strips: (TR) Angle or L-shape, height to match tile and setting-bed thickness, metallic base, designed specifically for ceramic tiling applications; aluminum exposed-edge material.
 1. Products: Schluter
 - a. Jolly profile

2.5 WATERPROOFING AND CRACK ISOLATION MEMBRANE

- A. General: Manufacturer's standard product that complies with ANSI A118.10 and is recommended by the manufacturer for the application indicated. Include reinforcement and accessories recommended by manufacturer.
- B. Fluid-Applied Membrane: Liquid-latex rubber or elastomeric polymer.
 1. Products: Subject to compliance with requirements, provide one of the following:
 - a. Laticrete International, Inc.; Hydro Ban.
 - b. Custom Building Products; RedGuard.

2.6 SETTING MATERIALS

- A. Latex-Portland Cement Mortar (Thin Set): ANSI A118.4.
 1. Manufacturers: Subject to compliance with requirements, provide products by one of the following:
 - a. Laticrete International, Inc.
 - b. MAPEI Corporation.
 - c. Custom Building Products

Weedsport Addition to Maintenance Section and Roof Replacement, MP 304.2

2. Provide prepackaged, dry-mortar mix containing dry, redispersible, vinyl acetate or acrylic additive to which only water must be added at Project site.
 3. For wall applications, provide mortar that complies with requirements for nonsagging mortar in addition to the other requirements in ANSI A118.4.
- B. Medium-Bed, Latex-Portland Cement Mortar: Comply with requirements in ANSI A118.4. Provide product that is approved by manufacturer for application thickness of 5/8 inch.
1. Manufacturers: Subject to compliance with requirements, provide products by one of the following:
 - a. Laticrete International, Inc.
 - b. MAPEI Corporation.
 - c. Custom Building Products
 2. Provide prepackaged, dry-mortar mix containing dry, redispersible, vinyl acetate or acrylic additive to which only water must be added at Project site.

2.7 GROUT MATERIALS

- A. Polymer-Modified Tile Grout: ANSI A118.7.
1. Products: Subject to compliance with requirements, provide the basis of design product indicated on the Color and Finish Schedule or the following equivalent products matching the basis of design products, characteristics and color.:
 - a. Laticrete International, Inc.
 - b. MAPEI Corporation.
 - c. Custom Building Products
 2. Polymer Type: Ethylene vinyl acetate or acrylic additive, in dry, redispersible form, prepackaged with other dry ingredients.

2.8 MISCELLANEOUS MATERIALS

- A. Trowelable Underlayments and Patching Compounds: Latex-modified, portland cement-based formulation provided or approved by manufacturer of tile-setting materials for installations indicated.
- B. Metal Edge Strips: Angle or L-shape, height to match tile and setting-bed thickness, metallic or combination of metal and PVC or neoprene base, designed specifically for flooring applications; stainless-steel, ASTM A 666, 300 Series] exposed-edge material.

2.9 MIXING MORTARS AND GROUT

- A. Mix mortars and grouts to comply with referenced standards and mortar and grout manufacturers' written instructions.
- B. Add materials, water, and additives in accurate proportions.
- C. Obtain and use type of mixing equipment, mixer speeds, mixing containers, mixing time, and other procedures to produce mortars and grouts of uniform quality with optimum performance characteristics for installations indicated.

PART 3 - EXECUTION

3.1 EXAMINATION

- A. Examine substrates, areas, and conditions where tile will be installed, with Installer present, for compliance with requirements for installation tolerances and other conditions affecting performance of installed tile.
1. Verify that substrates for setting tile are firm, dry, clean, free of coatings that are incompatible with tile-setting materials including curing compounds and other substances that contain soap, wax, oil, or silicone; and comply with flatness tolerances required by ANSI A108.01 for installations indicated.
 2. Verify that concrete substrates for tile floors installed with thin-set mortar comply with surface finish requirements in ANSI A108.01 for installations indicated.
 - a. Verify that surfaces that received a steel trowel finish have been mechanically scarified.
 - b. Verify that protrusions, bumps, and ridges have been removed by sanding or grinding.
 3. Verify that installation of grounds, anchors, recessed frames, electrical and mechanical units of work, and similar items located in or behind tile has been completed.
 4. Verify that joints and cracks in tile substrates are coordinated with tile joint locations; if not coordinated, adjust joint locations in consultation with Architect.
- B. Proceed with installation only after unsatisfactory conditions have been corrected.

3.2 PREPARATION

- A. Fill holes, and depressions in concrete substrates for tile floors installed with thin-set mortar with trowelable leveling and patching compound specifically recommended by tile-setting material manufacturer.
- B. For cracks, in concrete substrates for tile floors apply crack suppression membrane installed with specified reinforcement materials and adhesive compounds specifically recommended by tile-setting material manufacturer.
- C. Where indicated, prepare substrates to receive fluid applied waterproofing.
- D. Blending: For tile exhibiting color variations, verify that tile has been factory blended and packaged so tile units taken from one package show same range of colors as those taken from other packages and match approved Samples. If not factory blended, either return to manufacturer or blend tiles at Project site before installing.

3.3 TILE INSTALLATION

- A. Comply with TCA's "Handbook for Ceramic Tile Installation" for TCA installation methods specified in tile installation schedules. Comply with parts of the ANSI A108 Series "Specifications for Installation of Ceramic Tile" that are referenced in TCA installation methods, specified in tile installation schedules, and apply to types of setting and grouting materials used.
1. For the following installations, follow procedures in the ANSI A108 Series of tile installation standards for providing 95 percent mortar coverage:
 - a. Tile floors in wet areas

Weedsport Addition to Maintenance Section and Roof Replacement, MP 304.2

- b. Tile floors composed of tiles 8 by 8 inches or larger.
- B. Extend tile work into recesses and under or behind equipment and fixtures to form complete covering without interruptions unless otherwise indicated. Terminate work neatly at obstructions, edges, and corners without disrupting pattern or joint alignments.
- C. Accurately form intersections and returns. Perform cutting and drilling of tile without marring visible surfaces. Carefully grind cut edges of tile abutting trim, finish, or built-in items for straight aligned joints. Fit tile closely to electrical outlets, piping, fixtures, and other penetrations so plates, collars, or covers overlap tile.
- D. Provide manufacturer's standard trim shapes where necessary to eliminate exposed tile edges.
- E. Jointing Pattern: Lay tile in grid pattern unless otherwise indicated. Lay out tile work and center tile fields in both directions in each space or on each wall area. Lay out tile work to minimize the use of pieces that are less than half of a tile. Provide uniform joint widths unless otherwise indicated.
 - 1. For tile mounted in sheets, make joints between tile sheets same width as joints within tile sheets so joints between sheets are not apparent in finished work.
 - 2. Where adjoining tiles on floor, base, walls, or trim are specified or indicated to be same size, align joints.
 - 3. Where tiles are specified or indicated to be whole integer multiples of adjoining tiles on floor, base, walls, or trim, align joints unless otherwise indicated.
- F. Joint Widths: Unless otherwise indicated, install tile with the following joint widths:
 - 1. Ceramic Wall Tile: 1/16 inch.
 - 2. Ceramic Floor Tile: 1/8 inch.
- G. Lay out tile wainscots to dimensions indicated or to next full tile beyond dimensions indicated.
- H. Expansion Joints: Provide expansion joints and other sealant-filled joints, including control, contraction, and isolation joints, where indicated. Form joints during installation of setting materials, mortar beds, and tile. Do not saw-cut joints after installing tiles.
 - 1. Where joints occur in concrete substrates, locate joints in tile surfaces directly above them.
- I. Stone Thresholds: Install stone thresholds in same type of setting bed as adjacent floor unless otherwise indicated.
 - 1. At locations where mortar bed (thickset) would otherwise be exposed above adjacent floor finishes, set thresholds in latex-portland cement mortar (thin set).
 - 2. Do not extend waterproofing or crack isolation membrane under thresholds set in latex-portland cement mortar. Fill joints between such thresholds and adjoining tile set on waterproofing or crack isolation membrane with elastomeric sealant.
- J. Metal Edge Strips: Install where exposed edge of tile flooring meets carpet, wood, or other flooring that finishes flush with or below top of tile and no threshold is indicated.

3.4 TILE BACKING PANEL INSTALLATION

- A. Install cementitious backer units and treat joints according to ANSI A108.11 and manufacturer's written instructions for type of application indicated. Use latex-portland cement mortar for bonding material unless otherwise directed in manufacturer's written instructions.

Weedsport Addition to Maintenance Section and Roof Replacement, MP 304.2

3.5 WATERPROOFING INSTALLATION

- A. Install waterproofing to comply with ANSI A108.13 and manufacturer's written instructions to produce waterproof membrane of uniform thickness and bonded securely to substrate.
- B. Do not install tile or setting materials over waterproofing until waterproofing has cured and been tested to determine that it is watertight.

3.6 CRACK ISOLATION MEMBRANE INSTALLATION

- A. Install crack isolation membrane to comply with ANSI A108.17 and manufacturer's written instructions to produce membrane of uniform thickness and bonded securely to substrate.
- B. Do not install tile or setting materials over crack isolation membrane until membrane has cured.

3.7 CLEANING AND PROTECTING

- A. Cleaning: On completion of placement and grouting, clean all ceramic tile surfaces so they are free of foreign matter.
 - 1. Remove epoxy and latex-portland cement grout residue from tile as soon as possible.
 - 2. Clean grout smears and haze from tile according to tile and grout manufacturer's written instructions but no sooner than 10 days after installation. Use only cleaners recommended by tile and grout manufacturers and only after determining that cleaners are safe to use by testing on samples of tile and other surfaces to be cleaned. Protect metal surfaces and plumbing fixtures from effects of cleaning. Flush surfaces with clean water before and after cleaning.
 - 3. Remove temporary protective coating by method recommended by coating manufacturer and that is acceptable to tile and grout manufacturer. Trap and remove coating to prevent drain clogging.
- B. Protect installed tile work with kraft paper or other heavy covering during construction period to prevent staining, damage, and wear. If recommended by tile manufacturer, apply coat of neutral protective cleaner to completed tile walls and floors.
- C. Prohibit foot and wheel traffic from tiled floors for at least seven days after grouting is completed.
- D. Before final inspection, remove protective coverings and rinse neutral protective cleaner from tile surfaces.

3.8 INTERIOR TILE INSTALLATION SCHEDULE

- A. Interior Floor Installations, Concrete Subfloor:
 - 1. Tile Installation F122: Thin-set mortar on waterproof membrane; TCA F122.
 - a. Tile Type: As specified
 - b. Thin-Set Mortar: Latex- or Medium-bed, latex- portland cement mortar.
 - c. Grout: Polymer-modified sanded grout.
- B. Interior Wall Installations, Masonry or Concrete:
 - 1. Tile Installation W202: Thin-set mortar; TCA W202.
 - a. Tile Type: As specified.

Weedsport Addition to Maintenance Section and Roof Replacement, MP 304.2

- b. Thin-Set Mortar: Latex or Medium-bed, latex- portland cement mortar.
 - c. Grout: Polymer-modified sanded or Polymer-modified unsanded grout.
- C. Interior Wall Installations, Metal Studs or Furring:
- 1. Tile Installation W244: Thin-set mortar on cementitious backer units or fiber cement underlayment; TCA W244.
 - a. Tile Type: As specified.
 - b. Thin-Set Mortar: Latex- portland cement mortar.
 - c. Grout: Polymer-modified sanded or Polymer-modified unsanded grout.
- D. Shower Installations, Concrete Subfloor:
- 1. Tile Installation B421: Thin-set mortar on bonded waterproof membrane; TCNA B421.
 - a. Tile Type: As specified
 - b. Thin-Set Mortar: Latex- - portland cement mortar.
 - c. Grout: Polymer-modified sanded grout.
 - d. If drain with integrated bonding flange is used, provide TCNA method B422
- E.

END OF SECTION 093000

SECTION 095113 - ACOUSTICAL PANEL CEILINGS

PART 1 - GENERAL

1.1 SUMMARY

- A. Section includes acoustical panels and exposed suspension systems for ceilings.

1.2 PREINSTALLATION MEETINGS

- A. Preinstallation Conference: Conduct conference at Project site.

1.3 ACTION SUBMITTALS

- A. Product Data: For each type of product, including proposed hanger wire anchors.
- B. Samples: For each exposed product and for each color and texture specified, 6 inches in size.
- C. Samples for Initial Selection: For components with factory-applied color finishes.
- D. Samples for Verification: For each component indicated and for each exposed finish required, prepared on Samples of size indicated below.
1. Acoustical Panel: Set of 6-inch- square Samples of each type, color, pattern, and texture.
 2. Exposed Suspension-System Members, Moldings, and Trim: Set of 6-inch- long Samples of each type, finish, and color.

1.4 INFORMATIONAL SUBMITTALS

- A. Coordination Drawings: Reflected ceiling plans, drawn to scale, on which the following items are shown and coordinated with each other, using input from installers of the items involved:
1. Suspended ceiling components.
 2. Structural members to which suspension systems will be attached.
 3. Size and location of initial access modules for acoustical panels.
 4. Items penetrating finished ceiling including the following:
 - a. Lighting fixtures.
 - b. Air outlets and inlets.
 - c. Speakers.
 - d. Sprinklers.
 - e. Access panels.
 5. Perimeter moldings.
- B. Evaluation Reports: For each acoustical panel ceiling suspension system, from ICC-ES.
- C. Field quality-control reports.

1.5 CLOSEOUT SUBMITTALS

- A. Maintenance Data: For finishes to include in maintenance manuals.

1.6 MAINTENANCE MATERIAL SUBMITTALS

- A. Furnish extra materials that match products installed and that are packaged with protective covering for storage and identified with labels describing contents.
1. Acoustical Ceiling Panels: Full-size panels equal to 2 percent of quantity installed.

Weedsport Addition to Maintenance Section and Roof Replacement, MP 304.2

2. Suspension-System Components: Quantity of each exposed component equal to 2 percent of quantity installed.
3. Hold-Down Clips: Equal to 2 percent of quantity installed.

1.7 QUALITY ASSURANCE

- A. Test reports: Manufacturer will provide test certification for minimum requirements as tested in accordance with applicable industry standards and/or to meet performance standards specified by various agencies.
- B. Changes from system: System performance following any substitution of materials or change in assembly design must be certified by the manufacturer.
- C. All ceiling panel cartons must contain UL label for acoustical compliance.
- D. All suspension system cartons must contain UL label for load compliance per ASTM C635.

1.8 DELIVERY, STORAGE, AND HANDLING

- A. Deliver acoustical panels, suspension-system components, and accessories to Project site in original, unopened packages and store them in a fully enclosed, conditioned space where they will be protected against damage from moisture, humidity, temperature extremes, direct sunlight, surface contamination, and other causes.
- B. Before installing acoustical panels, permit them to reach room temperature and a stabilized moisture content.
- C. Handle acoustical panels carefully to avoid chipping edges or damaging units in any way.

1.9 FIELD CONDITIONS

- A. Environmental Limitations: Do not install acoustical panel ceilings until spaces are enclosed and weatherproof, wet work in spaces is complete and dry, work above ceilings is complete, and ambient temperature and humidity conditions are maintained at the levels indicated for Project when occupied for its intended use.
 1. Pressurized Plenums: Operate ventilation system for not less than 48 hours before beginning acoustical panel ceiling installation.

PART 2 - PRODUCTS**2.1 PERFORMANCE REQUIREMENTS**

- A. Seismic Performance: Acoustical ceiling shall withstand the effects of earthquake motions determined according to Seismic Category C.
 1. Provide manufacturer's approved and tested seismic assembly complying with:
 - a. American Society of Civil Engineers 7-05: Minimum Design Loads for Buildings and Other Structures.
 - b. CISCA: Guidelines for Seismic Restraint Direct Hung Suspended Ceiling Assemblies Seismic Zones 3 & 4.
- B. Surface-Burning Characteristics: Comply with ASTM E 84; testing by a qualified testing agency. Identify products with appropriate markings of applicable testing agency.
 1. Flame-Spread Index: Comply with ASTM E 1264 for Class A materials.
 2. Smoke-Developed Index: 50 or less.

Weedsport Addition to Maintenance Section and Roof Replacement, MP 304.2

- C. Fire-Resistance Ratings: Comply with ASTM E 119; testing by a qualified testing agency. Identify products with appropriate markings of applicable testing agency.
1. Indicate design designations from UL's "Fire Resistance Directory" or from the listings of another qualified testing agency.

2.2 ACOUSTICAL PANELS, GENERAL

- A. Low-Emitting Materials: Acoustical panel ceilings shall comply with the testing and product requirements of the California Department of Health Services' "Standard Practice for the Testing of Volatile Organic Emissions from Various Sources Using Small-Scale Environmental Chambers."
- B. Source Limitations:
1. Acoustical Ceiling Panel: Obtain each type from single source from single manufacturer.
 2. Suspension System: Obtain each type from single source from single manufacturer.
- C. Source Limitations: Obtain each type of acoustical ceiling panel and supporting suspension system from single source from single manufacturer.
- D. Glass-Fiber-Based Panels: Made with binder containing no urea formaldehyde.
- E. Acoustical Panel Standard: Provide manufacturer's standard panels of configuration indicated that comply with ASTM E 1264 classifications as designated by types, patterns, acoustical ratings, and light reflectances unless otherwise indicated.
1. Mounting Method for Measuring NRC: Type E-400; plenum mounting in which face of test specimen is 15-3/4 inches away from test surface according to ASTM E 795.
- F. Acoustical Panel Colors and Patterns: Match appearance characteristics indicated for each product type.
1. Where appearance characteristics of acoustical panels are indicated by referencing pattern designations in ASTM E 1264 and not manufacturers' proprietary product designations, provide products selected by Architect from each manufacturer's full range that comply with requirements indicated for type, pattern, color, light reflectance, acoustical performance, edge detail, and size.

2.3 ACOUSTICAL PANELS - ACT-1

- A. Basis-of-Design Product: Subject to compliance with requirements, provide "School Zone® Fine Fissured™ #1713" by Armstrong World Industries or comparable product by one of the following:
1. USG Corp.
 2. CertainTeed Corp.
- B. Classification: Provide panels complying with ASTM E 1264 for type, form, and pattern as follows:
1. Type and Form: Type III, mineral base with painted finish; Form 2, water felted.
 2. Pattern: C (perforated, small holes)) E (lightly textured).
- C. Fire Classification: Class A.
- D. Color: White.
- E. NRC: Not less than 0.70.
- F. CAC: Not less than 35.
- G. Edge/Joint Detail: Square.

Weedsport Addition to Maintenance Section and Roof Replacement, MP 304.2

- H. Thickness: 3/4 inch.
- I. Modular Size: 24 by 24 inches.

2.4 METAL SUSPENSION SYSTEMS, GENERAL

- A. Metal Suspension-System Standard: Provide manufacturer's standard direct-hung metal suspension systems of types, structural classifications, and finishes indicated that comply with applicable requirements in ASTM C 635/C 635M.
 - 1. High-Humidity Finish: Comply with ASTM C 635/C 635M requirements for "Coating Classification for Severe Environment Performance" where high-humidity finishes are indicated.
- B. Attachment Devices: Size for five times the design load indicated in ASTM C 635/C 635M, Table 1, "Direct Hung," unless otherwise indicated. Comply with seismic design requirements.
 - 1. Anchors in Concrete: Anchors of type and material indicated below, with holes or loops for attaching hangers of type indicated and with capability to sustain, without failure, a load equal to five times that imposed by ceiling construction, as determined by testing according to ASTM E 488 or ASTM E 1512 as applicable, conducted by a qualified testing and inspecting agency.
 - a. Type: Postinstalled expansion anchors.
 - b. Corrosion Protection: Carbon-steel components zinc plated to comply with ASTM B 633, Class Fe/Zn 5 (0.005 mm) for Class SC 1 service condition.
 - c. Corrosion Protection: Stainless-steel components complying with ASTM F 593 and ASTM F 594, Group 1 Alloy 304 or 316 for bolts; Alloy 304 or 316 for anchor.
 - d. Corrosion Protection: Components fabricated from nickel-copper-alloy rods complying with ASTM B 164 for UNS No. N04400 alloy.
 - 2. Power-Actuated Fasteners in Concrete: Fastener system of type suitable for application indicated, fabricated from corrosion-resistant materials, with clips or other accessory devices for attaching hangers of type indicated and with capability to sustain, without failure, a load equal to 10 times that imposed by ceiling construction, as determined by testing according to ASTM E 1190, conducted by a qualified testing and inspecting agency.
- C. Wire Hangers, Braces, and Ties: Provide wires complying with the following requirements:
 - 1. Zinc-Coated, Carbon-Steel Wire: ASTM A 641/A 641M, Class 1 zinc coating, soft temper.
 - 2. Stainless-Steel Wire: ASTM A 580/A 580M, Type 304, nonmagnetic.
 - 3. Nickel-Copper-Alloy Wire: ASTM B 164, nickel-copper-alloy UNS No. N04400.
 - 4. Size: Select wire diameter so its stress at three times hanger design load (ASTM C 635/C 635M, Table 1, "Direct Hung") will be less than yield stress of wire, but provide not less than 0.106-inch- diameter wire.
- D. Hanger Rods: Mild steel, zinc coated or protected with rust-inhibitive paint.
- E. Angle Hangers: Angles with legs not less than 7/8 inch wide; formed with 0.04-inch- thick, galvanized-steel sheet complying with ASTM A 653/A 653M, G90 coating designation; with bolted connections and 5/16-inch- diameter bolts.
- F. Seismic Stabilizer Bars: Manufacturer's standard perimeter stabilizers designed to accommodate seismic forces.

Weedsport Addition to Maintenance Section and Roof Replacement, MP 304.2

- G. Seismic Struts: Manufacturer's standard compression struts designed to accommodate seismic forces.
- H. Seismic Clips: Manufacturer's standard seismic clips designed and spaced to secure acoustical panels in place.
- I. Hold-Down Clips: Where indicated, provide manufacturer's standard hold-down clips spaced 24 inches o.c. on all cross tees.
- J. Impact Clips: Where indicated, provide manufacturer's standard impact-clip system designed to absorb impact forces against acoustical panels.

2.5 METAL SUSPENSION SYSTEM

- A. Manufacturers: Subject to compliance with requirements, available manufacturers offering products that may be incorporated into the Work include, but are not limited to, the following:
 1. Armstrong World Industries, Inc.
 2. CertainTeed Corp.
 3. Chicago Metallic Corporation.
 4. USG Interiors, Inc.; Subsidiary of USG Corporation.
- B. Wide-Face, Capped, Double-Web, Steel Suspension System: Main and cross runners roll formed from cold-rolled steel sheet; prepainted, electrolytically zinc coated, or hot-dip galvanized according to ASTM A 653/A 653M, not less than G30 coating designation; with prefinished 15/16-inch- wide metal caps on flanges.
 1. Structural Classification: Heavy-duty system.
 2. End Condition of Cross Runners: Override (stepped) or butt-edge type.
 3. Face Design: Flat, flush.
 4. Cap Material: Steel or aluminum cold-rolled sheet.
 5. Cap Finish: Painted white or flat black to match panel color.
 6. Basis of Design: Prelude

2.6 METAL EDGE MOLDINGS AND TRIM

- A. Manufacturers: Subject to compliance with requirements, available manufacturers offering products that may be incorporated into the Work include, but are not limited to, the following:
 1. Armstrong World Industries, Inc.
 2. CertainTeed Corp.
 3. Chicago Metallic Corporation.
 4. USG Interiors, Inc.; Subsidiary of USG Corporation.
- B. Roll-Formed, Sheet-Metal Edge Moldings and Trim: Type and profile indicated or, if not indicated, manufacturer's standard moldings for edges and penetrations that comply with seismic design requirements; formed from sheet metal of same material, finish, and color as that used for exposed flanges of suspension-system runners.
 1. Provide manufacturer's standard edge moldings that fit acoustical panel edge details and suspension systems indicated and that match width and configuration of exposed runners unless otherwise indicated.
 2. For circular penetrations of ceiling, provide edge moldings fabricated to diameter required to fit penetration exactly.
 3. Outside Corner: Prefabricated corner cap; formed to 90° angle; hemmed edge; size and finish to match wall molding.

Weedsport Addition to Maintenance Section and Roof Replacement, MP 304.2

2.7 ACOUSTICAL SEALANT

- A. Products: Subject to compliance with requirements, available products that may be incorporated into the Work include, but are not limited to, the following:
1. Acoustical Sealant for Exposed and Concealed Joints:
 - a. Pecora Corporation; AC-20 FTR Acoustical and Insulation Sealant.
 - b. USG Corporation; SHEETROCK Acoustical Sealant.
 2. Acoustical Sealant for Concealed Joints:
 - a. Henkel Corporation; OSI Pro-Series SC-175 Acoustical Sound Sealant.
 - b. Pecora Corporation; AIS-919.
 - c. Tremco, Inc.; Tremco Acoustical Sealant.
- B. Acoustical Sealant: Manufacturer's standard sealant complying with ASTM C 834 and effective in reducing airborne sound transmission through perimeter joints and openings in building construction as demonstrated by testing representative assemblies according to ASTM E 90.
1. Exposed and Concealed Joints: Nonsag, paintable, nonstaining latex sealant.
 2. Concealed Joints: Nondrying, nonhardening, nonskinning, nonstaining, gunnable, synthetic-rubber sealant.
 3. Acoustical sealant shall have a VOC content of 250 g/L or less when calculated according to 40 CFR 59, Subpart D (EPA Method 24).

PART 3 - EXECUTION**3.1 EXAMINATION**

- A. Examine substrates, areas, and conditions, including structural framing to which acoustical panel ceilings attach or abut, with Installer present, for compliance with requirements specified in this and other Sections that affect ceiling installation and anchorage and with requirements for installation tolerances and other conditions affecting performance of acoustical panel ceilings.
- B. Examine acoustical panels before installation. Reject acoustical panels that are wet, moisture damaged, or mold damaged.
- C. Proceed with installation only after unsatisfactory conditions have been corrected.

3.2 PREPARATION

- A. Measure each ceiling area and establish layout of acoustical panels to balance border widths at opposite edges of each ceiling. Avoid using less-than-half-width panels at borders, and comply with layout shown on reflected ceiling plans.

3.3 INSTALLATION

- A. General: Install acoustical panel ceilings to comply with ASTM C 636/C 636M and seismic design requirements indicated, according to manufacturer's written instructions and CISCA's "Ceiling Systems Handbook."
1. Fire-Rated Assembly: Install fire-rated ceiling systems according to tested fire-rated design.
- B. Suspend ceiling hangers from building's structural members and as follows:
1. Install hangers plumb and free from contact with insulation or other objects within ceiling plenum that are not part of supporting structure or of ceiling suspension system.
 2. Splay hangers only where required to miss obstructions; offset resulting horizontal forces by bracing, countersplaying, or other equally effective means.

Weedsport Addition to Maintenance Section and Roof Replacement, MP 304.2

3. Where width of ducts and other construction within ceiling plenum produces hanger spacings that interfere with location of hangers at spacings required to support standard suspension-system members, install supplemental suspension members and hangers in form of trapezes or equivalent devices.
 4. Secure wire hangers to ceiling-suspension members and to supports above with a minimum of three tight turns. Connect hangers directly either to structures or to inserts, eye screws, or other devices that are secure and appropriate for substrate and that will not deteriorate or otherwise fail due to age, corrosion, or elevated temperatures.
 5. Secure flat, angle, channel, and rod hangers to structure, including intermediate framing members, by attaching to inserts, eye screws, or other devices that are secure and appropriate for both the structure to which hangers are attached and the type of hanger involved. Install hangers in a manner that will not cause them to deteriorate or fail due to age, corrosion, or elevated temperatures.
 6. Do not support ceilings directly from permanent metal forms or floor deck. Fasten hangers to cast-in-place hanger inserts, postinstalled mechanical or adhesive anchors, or power-actuated fasteners that extend through forms into concrete.
 7. When steel framing does not permit installation of hanger wires at spacing required, install carrying channels or other supplemental support for attachment of hanger wires.
 8. Do not attach hangers to steel deck tabs.
 9. Do not attach hangers to steel roof deck. Attach hangers to structural members.
 10. Space hangers not more than 48 inches o.c. along each member supported directly from hangers unless otherwise indicated; provide hangers not more than 8 inches from ends of each member.
 11. Size supplemental suspension members and hangers to support ceiling loads within performance limits established by referenced standards and publications.
- C. Secure bracing wires to ceiling suspension members and to supports with a minimum of four tight turns. Suspend bracing from building's structural members as required for hangers, without attaching to permanent metal forms, steel deck, or steel deck tabs. Fasten bracing wires into concrete with cast-in-place or post installed anchors.
- D. Install edge moldings and trim of type indicated at perimeter of acoustical ceiling area and where necessary to conceal edges of acoustical panels.
1. Apply acoustical sealant in a continuous ribbon concealed on back of vertical legs of moldings before they are installed.
 2. Screw attach moldings to substrate at intervals not more than 16 inches o.c. and not more than 3 inches from ends, leveling with ceiling suspension system to a tolerance of 1/8 inch in 12 feet. Miter corners accurately and connect securely.
 3. Do not use exposed fasteners, including pop rivets, on moldings and trim.
- E. Ceiling Perimeter (Seismic Considerations): Install edge moldings (7/8" minimum) and trim of type indicated at perimeter of acoustical ceiling area and where necessary to conceal edges of acoustical panels.
1. Tee ends shall be tied together with manufacturer supplied Stabilizer Bars or other approved means to prevent the tees from spreading apart.
 2. Maintain a 3/8" clearance between the ends of the suspension members and the wall. The unattached ends of the suspension members shall rest upon and be free to slide perpendicularly to the perimeter molding.
 3. Alternate Perimeter Attachment: When approved by local code officials install 7/8" edge molding with grid manufacturers Seismic Clip accessory in lieu of stabilizer bars.

Weedsport Addition to Maintenance Section and Roof Replacement, MP 304.2

- F. Install suspension-system runners so they are square and securely interlocked with one another. Remove and replace dented, bent, or kinked members.
- G. Install acoustical panels with undamaged edges and fit accurately into suspension-system runners and edge moldings. Scribe and cut panels at borders and penetrations to provide a neat, precise fit.
 - 1. For square-edged panels, install panels with edges fully hidden from view by flanges of suspension-system runners and moldings.
 - 2. For reveal-edged panels on suspension-system runners, install panels with bottom of reveal in firm contact with top surface of runner flanges.
 - 3. For reveal-edged panels on suspension-system members with box-shaped flanges, install panels with reveal surfaces in firm contact with suspension-system surfaces and panel faces flush with bottom face of runners.
 - 4. Paint cut edges of panel remaining exposed after installation; match color of exposed panel surfaces using coating recommended in writing for this purpose by acoustical panel manufacturer.
 - 5. Install hold-down clips in areas indicated, in areas required by authorities having jurisdiction, and for fire-resistance ratings; space as recommended by panel manufacturer's written instructions unless otherwise indicated.
 - 6. Install clean-room gasket system in areas indicated, sealing each panel and fixture as recommended by panel manufacturer's written instructions.
 - 7. Protect lighting fixtures and air ducts to comply with requirements indicated for fire-resistance-rated assembly.

3.4 CLEANING

- A. Clean exposed surfaces of acoustical panel ceilings, including trim, edge moldings, and suspension-system members. Comply with manufacturer's written instructions for cleaning and touchup of minor finish damage. Remove and replace ceiling components that cannot be successfully cleaned and repaired to permanently eliminate evidence of damage.

END OF SECTION 095113

SECTION 096513 - RESILIENT BASE AND ACCESSORIES

PART 1 - GENERAL

1.1 SUMMARY

- A. Section Includes:
1. Resilient base.
 2. Resilient molding accessories.

1.2 ACTION SUBMITTALS

- A. Product Data: For each type of product.
- B. Samples: For each exposed product and for each color and texture specified, not less than 12 inches long.
- C. Samples for Initial Selection: For each type of product indicated.
- D. Product Schedule: For resilient base and accessory products.

1.3 MAINTENANCE MATERIAL SUBMITTALS

- A. Furnish extra materials that match products installed and that are packaged with protective covering for storage and identified with labels describing contents.
1. Furnish not less than 10 linear feet for every 500 linear feet or fraction thereof, of each type, color, pattern, and size of resilient product installed.

1.4 QUALITY ASSURANCE

- A. Mockups: Build mockups to verify selections made under Sample submittals and to demonstrate aesthetic effects and set quality standards for materials and execution.
1. Coordinate mockups in this Section with mockups specified in other Sections.

1.5 DELIVERY, STORAGE, AND HANDLING

- A. Store resilient products and installation materials in dry spaces protected from the weather, with ambient temperatures maintained within range recommended by manufacturer, but not less than 50 deg F or more than 90 deg F.

1.6 FIELD CONDITIONS

- A. Maintain ambient temperatures within range recommended by manufacturer, but not less than 70 deg F or more than 90 deg F. Insert temperature, in spaces to receive resilient products during the following time periods:
1. 48 hours before installation.
 2. During installation.
 3. 48 hours after installation.
- B. After installation and until Substantial Completion, maintain ambient temperatures within range recommended by manufacturer, but not less than 55 deg F or more than 90 deg F.

Weedsport Addition to Maintenance Section and Roof Replacement, MP 304.2

- C. Install resilient products after other finishing operations, including painting, have been completed.

PART 2 - PRODUCTS

2.1 PERFORMANCE REQUIREMENTS

- A. Low-Emitting Materials: Flooring system shall comply with the testing and product requirements of the California Department of Public Health's "Standard Method for the Testing and Evaluation of Volatile Organic Chemical Emissions from Indoor Sources Using Environmental Chambers."]

2.2 VINYL BASE

- A. Basis of Design Product: Subject to compliance with requirements, provide Johnsonite "Traditional Wall Base" or a comparable product by one of the following:
1. Armstrong World Industries, Inc.
 2. Nora Systems, Inc.
 3. Roppe Corporation, USA.
- B. Product Standard: ASTM F1861, Type TV (vinyl, thermoplastic).
1. Group: I (solid, homogeneous).
 2. Style and Location:
 - a. Style B, Cove: .
- C. Minimum Thickness: 0.125 inch (3.2 mm).
- D. Height: 4 inches (102 mm).
- E. Lengths: Coils in manufacturer's standard length.
- F. Outside Corners: Job formed or preformed.
- G. Inside Corners: Job formed or preformed.
- H. Colors and Patterns: As selected by Architect.

2.3 INSTALLATION MATERIALS

- A. Trowelable Leveling and Patching Compounds: Latex-modified, portland cement based or blended hydraulic-cement-based formulation provided or approved by resilient-product manufacturer for applications indicated.
- B. Adhesives: Water-resistant type recommended by resilient-product manufacturer for resilient products and substrate conditions indicated.
1. Adhesives shall have a VOC content of 50 g/L or less.
- C. Metal Edge Strips: Extruded aluminum with mill finish of width shown, of height required to protect exposed edges of flooring, and in maximum available lengths to minimize running joints.

PART 3 - EXECUTION

3.1 EXAMINATION

- A. Examine substrates, with Installer present, for compliance with requirements for maximum moisture content and other conditions affecting performance of the Work.
 - 1. Verify that finishes of substrates comply with tolerances and other requirements specified in other Sections and that substrates are free of cracks, ridges, depressions, scale, and foreign deposits that might interfere with adhesion of resilient products.
- B. Proceed with installation only after unsatisfactory conditions have been corrected.
 - 1. Installation of resilient products indicates acceptance of surfaces and conditions.

3.2 PREPARATION

- A. Prepare substrates according to manufacturer's written instructions to ensure adhesion of resilient products.
- B. Concrete Substrates for Resilient Stair Accessories: Prepare horizontal surfaces according to ASTM F 710.
 - 1. Verify that substrates are dry and free of curing compounds, sealers, and hardeners.
 - 2. Remove substrate coatings and other substances that are incompatible with adhesives and that contain soap, wax, oil, or silicone, using mechanical methods recommended by manufacturer. Do not use solvents.
 - 3. Alkalinity and Adhesion Testing: Perform tests recommended by manufacturer. Proceed with installation only after substrate alkalinity falls within range on pH scale recommended by manufacturer in writing, but not less than 5 or more than 9 pH.
 - 4. Moisture Testing: Proceed with installation only after substrates pass testing according to manufacturer's written recommendations, but not less stringent than the following:
 - a. Perform anhydrous calcium chloride test according to ASTM F 1869. Proceed with installation only after substrates have maximum moisture-vapor-emission rate of 3 lb of water/1000 sq. ft. in 24 hours.
 - b. Perform relative humidity test using in situ probes according to ASTM F 2170. Proceed with installation only after substrates have maximum 75 percent relative humidity level.
- C. Fill cracks, holes, and depressions in substrates with trowelable leveling and patching compound; remove bumps and ridges to produce a uniform and smooth substrate.
- D. Do not install resilient products until they are the same temperature as the space where they are to be installed.
 - 1. At least 48 hours in advance of installation, move resilient products and installation materials into spaces where they will be installed.
- E. Immediately before installation, sweep and vacuum clean substrates to be covered by resilient products.

Weedsport Addition to Maintenance Section and Roof Replacement, MP 304.2

3.3 RESILIENT BASE INSTALLATION

- A. Comply with manufacturer's written instructions for installing resilient base.
- B. Apply resilient base to walls, columns, pilasters, casework and cabinets in toe spaces, and other permanent fixtures in rooms and areas where base is required.
- C. Install resilient base in lengths as long as practical without gaps at seams and with tops of adjacent pieces aligned.
- D. Tightly adhere resilient base to substrate throughout length of each piece, with base in continuous contact with horizontal and vertical substrates.
- E. Do not stretch resilient base during installation.
- F. On masonry surfaces or other similar irregular substrates, fill voids along top edge of resilient base with manufacturer's recommended adhesive filler material.
- G. Preformed Corners: Install preformed corners before installing straight pieces.
- H. Job-Formed Corners:
 - 1. Inside Corners: Use straight pieces of maximum lengths possible and form with returns not less than 3 inches in length.
 - a. Miter corners to minimize open joints.

3.4 CLEANING AND PROTECTION

- A. Comply with manufacturer's written instructions for cleaning and protecting resilient products.
- B. Perform the following operations immediately after completing resilient-product installation:
 - 1. Remove adhesive and other blemishes from exposed surfaces.
 - 2. Sweep and vacuum horizontal surfaces thoroughly.
 - 3. Damp-mop horizontal surfaces to remove marks and soil.
- C. Protect resilient products from mars, marks, indentations, and other damage from construction operations and placement of equipment and fixtures during remainder of construction period.
- D. Floor Polish: Remove soil, visible adhesive, and surface blemishes from resilient stair treads before applying liquid floor polish.
 - 1. Apply three coat(s).
- E. Cover resilient products subject to wear and foot traffic until Substantial Completion.

END OF SECTION 096513

SECTION 096519 - RESILIENT TILE FLOORING

PART 1 - GENERAL

1.1 SUMMARY

- A. Section Includes:
1. Solid Vinyl Floor Tile
 2. Luxury Vinyl Floor Tile.
 3. Moisture Mitigation Membrane
 4. Flooring Protection

1.2 ACTION SUBMITTALS

- A. Product Data: For each type of product.
- B. Shop Drawings: For each type of floor tile. Include floor tile layouts, edges, columns, doorways, enclosing partitions, built-in furniture, cabinets, and cutouts.
1. Show details of special patterns.
- C. Samples: Full-size units of each color and pattern of floor tile required.
- D. Samples for Initial Selection: For each type of floor tile indicated.
- E. Samples for Verification: Full-size units of each color and pattern of floor tile required.
- F. Product Schedule: For floor tile. Use same designations indicated on Drawings.

1.3 INFORMATIONAL SUBMITTALS

- A. Qualification Data: For Installer.

1.4 CLOSEOUT SUBMITTALS

- A. Maintenance Data: For each type of floor tile to include in maintenance manuals.

1.5 QUALITY ASSURANCE

- A. Installer Qualifications: A qualified installer who employs workers for this Project who are competent in techniques required by manufacturer for floor tile installation and seaming method indicated.
1. Engage an installer who employs workers for this Project who are trained or certified by floor tile manufacturer for installation techniques required.
- B. Mockups: Build mockups to verify selections made under Sample submittals and to demonstrate aesthetic effects and set quality standards for materials and execution.
1. Build mockups for floor tile including resilient base and accessories.
 - a. Size: Minimum 100 sq. ft. for each type, color, and pattern in locations directed by Architect.

Weedsport Addition to Maintenance Section and Roof Replacement, MP 304.2

2. Approval of mockups does not constitute approval of deviations from the Contract Documents contained in mockups unless Architect specifically approves such deviations in writing.
 3. Subject to compliance with requirements, approved mockups may become part of the completed Work if undisturbed at time of Substantial Completion.
- C. All flooring types and colors to be furnished for this project shall be from the same production run and dye lot.

1.6 DELIVERY, STORAGE, AND HANDLING

- A. Store floor tile and installation materials in dry spaces protected from the weather, with ambient temperatures maintained within range recommended by manufacturer, but not less than 50 deg F or more than 90 deg F. Store floor tiles on flat surfaces.

1.7 FIELD CONDITIONS

- A. Maintain ambient temperatures within range recommended by manufacturer, but not less than 70 deg F or more than 90 deg F, in spaces to receive floor tile during the following time periods:
1. 48 hours before installation.
 2. During installation.
 3. 48 hours after installation.
- B. After installation and until Substantial Completion, maintain ambient temperatures within range recommended by manufacturer, but not less than 55 deg F or more than 90 deg F.
- C. Close spaces to traffic during floor tile installation.
- D. Close spaces to traffic for 48 hours after floor tile installation.
- E. Install floor tile after other finishing operations, including painting, have been completed.

PART 2 - PRODUCTS**2.1 PERFORMANCE REQUIREMENTS**

- A. Fire-Test-Response Characteristics: For resilient tile flooring, as determined by testing identical products according to ASTM E 648 or NFPA 253 by a qualified testing agency.
1. Critical Radiant Flux Classification: Class I, not less than 0.45 W/sq. cm.
- B. FloorScore Compliance: Resilient tile flooring shall comply with requirements of FloorScore certification.
- C. Low-Emitting Materials: Flooring system shall comply with the testing and product requirements of the California Department of Public Health's "Standard Method for the Testing and Evaluation of Volatile Organic Chemical Emissions from Indoor Sources Using Environmental Chambers."

2.2 SOLID VINYL FLOOR TILE

- A. Basis of Design: TOLI Corporation, LIGHTWOOD (150mm plank)

Weedsport Addition to Maintenance Section and Roof Replacement, MP 304.2

- B. Thickness: 0.120 inch (3.0 mm).
- C. Surface clear wear layer 0.5mm
- D. Fine-beveled
- E. Size: 150 by 900 mm
- F. Colors and Patterns: As selected by Architect

2.3 INSTALLATION MATERIALS

- A. Moisture Mitigation Membrane: Provide one component moisture vapor retarder.
 - 1. Product: Ardex VR 98, Mapei Planiseal MSP or TEC Liquidam EZ
 - 2. Apply to concrete slabs to receive resilient sheet flooring.
- B. Trowelable Leveling and Patching Compounds: Latex-modified, portland cement based or blended hydraulic-cement-based formulation provided or approved by floor tile manufacturer for applications indicated.
 - 1. Products:
 - a. Ardex Feather Finish
 - b. Mapei Planipatch
- C. Adhesives: Water-resistant type recommended by floor tile and adhesive manufacturers to suit floor tile and substrate conditions indicated.
 - 1. Adhesives shall comply with the following limits for VOC content:
 - a. Vinyl Tile Adhesives: 50 g/L or less.
 - 2. Adhesives shall comply with the testing and product requirements of the California Department of Public Health's "Standard Method for the Testing and Evaluation of Volatile Organic Chemical Emissions from Indoor Sources Using Environmental Chambers."
- D. Special Adhesive for Solid Vinyl Tiles
 - 1. Manufacturer: Tarkett
 - a. Product: 926 Adhesive
 - 2. Manufacturer: Toli International
 - a. Product: CBC 5001 High Performance Adhesive

2.4 FLOOR PROTECTION MATERIALS

- A. Provide floor protection product in areas of completed work.
 - 1. Product: Ram Board
 - 2. Seam Tape: Vapor Cure Tape.

PART 3 - EXECUTION**3.1 EXAMINATION**

- A. Examine substrates, with Installer present, for compliance with requirements for maximum moisture content and other conditions affecting performance of the Work.

Weedsport Addition to Maintenance Section and Roof Replacement, MP 304.2

1. Verify that finishes of substrates comply with tolerances and other requirements specified in other Sections and that substrates are free of cracks, ridges, depressions, scale, and foreign deposits that might interfere with adhesion of floor tile.
- B. Proceed with installation only after unsatisfactory conditions have been corrected.

3.2 PREPARATION

- A. Prepare substrates according to floor tile manufacturer's written instructions to ensure adhesion of resilient products.
- B. Concrete Substrates: Prepare according to ASTM F 710.
1. Verify that substrates are dry and free of curing compounds, sealers, and hardeners.
 - a. Coordinate removal of existing flooring systems with the selective demolition and asbestos abatement specifications.
 2. Remove substrate coatings and other substances that are incompatible with adhesives and that contain soap, wax, oil, or silicone, using mechanical methods recommended by floor tile manufacturer. Do not use solvents.
 - a. If Solvent methods are used to remove asbestos mastics comply with the procedures outlined in the asbestos abatement specifications regarding solvent removal of mastics.
 3. Alkalinity and Adhesion Testing: Perform tests recommended by floor tile manufacturer. Proceed with installation only after substrate alkalinity falls within range on pH scale recommended by manufacturer in writing, but not less than 5 or more than 9 pH.
 4. Moisture Testing: Proceed with installation only after substrates pass testing according to floor tile manufacturer's written recommendations, but not less stringent than the following:
 - a. Perform relative humidity test using in situ probes according to ASTM F 2170. Proceed with installation only after substrates have a maximum 75 percent relative humidity level.
- C. Vapor Retarder; Apply moisture mitigation membrans/vapor retarder to a properly prepared substrate per manufacturers requirements. Sequence with leveling and patching process as recommended by manufacturer.
- D. Floor Preparation Sequence
1. Fill cracks, holes, and depressions in substrates with trowelable leveling and patching compound; remove bumps and ridges.
 2. Flash Patch and Skim Coat the entire floor surface. Lightly sand ridges and bumps using a commercial grade floor sander to produce uniform and smooth substrate.
- E. Do not install floor tiles until they are the same temperature as the space where they are to be installed.
1. At least 48 hours in advance of installation, move resilient floor tile and installation materials into spaces where they will be installed.
- F. Immediately before installation, sweep and vacuum clean substrates to be covered by resilient floor tile.

3.3 FLOOR TILE INSTALLATION

- A. Comply with manufacturer's written instructions for installing floor tile.

Weedsport Addition to Maintenance Section and Roof Replacement, MP 304.2

- B. Lay out floor tiles from center marks established with principal walls, discounting minor offsets, so tiles at opposite edges of room are of equal width. Adjust as necessary to avoid using cut widths that equal less than one-half tile at perimeter.
- C. Match floor tiles for color and pattern by selecting tiles from cartons in the same sequence as manufactured and packaged, if so numbered. Discard broken, cracked, chipped, or deformed tiles.
- D. Scribe, cut, and fit floor tiles to butt neatly and tightly to vertical surfaces and permanent fixtures including built-in furniture, cabinets, pipes, outlets, and door frames.
- E. Water Jet cut flooring materials at flooring pattern changes where indicated on the drawings.
- F. Extend floor tiles into toe spaces, door reveals, closets, and similar openings. Extend floor tiles to center of door openings.
- G. Maintain reference markers, holes, and openings that are in place or marked for future cutting by repeating on floor tiles as marked on substrates. Use chalk or other nonpermanent marking device.
- H. Install floor tiles on covers for telephone and electrical ducts, building expansion-joint covers, and similar items in finished floor areas. Maintain overall continuity of color and pattern between pieces of tile installed on covers and adjoining tiles. Tightly adhere tile edges to substrates that abut covers and to cover perimeters.
- I. Adhere floor tiles to flooring substrates using a full spread of adhesive applied to substrate to produce a completed installation without open cracks, voids, raising and puckering at joints, telegraphing of adhesive spreader marks, and other surface imperfections.

3.4 CLEANING AND PROTECTION

- A. Comply with manufacturer's written instructions for cleaning and protecting floor tile.
- B. Perform the following operations immediately after completing floor tile installation:
 - 1. Remove adhesive and other blemishes from exposed surfaces.
 - 2. Sweep and vacuum surfaces thoroughly.
 - 3. Damp-mop surfaces to remove marks and soil.
- C. Protect floor tile from marks, marks, indentations, and other damage from construction operations and placement of equipment and fixtures during remainder of construction period.
- D. Cover floor coverings with specified floor protection material in accordance with manufacturer's instructions until Substantial Completion

END OF SECTION 096519

SECTION 099113 - EXTERIOR PAINTING

PART 1 - GENERAL

1.1 SUMMARY

- A. Section includes surface preparation and the application of paint systems on exterior substrates.
- B. Related Requirements:
 - 1. Section 099600 "High-Performance Coatings" for special-use coatings.
 - 2. Section 099123 "Interior Painting" for surface preparation and the application of paint systems on interior substrates.

1.2 DEFINITIONS

- A. Gloss Level 1: Not more than 5 units at 60 degrees and 10 units at 85 degrees, according to ASTM D 523, a matte flat finish.
- B. Gloss Level 2: Not more than 10 units at 60 degrees and 10 to 35 units at 85 degrees, according to ASTM D 523, a high-side sheen flat, velvet-like finish.
- C. Gloss Level 3: 10 to 25 units at 60 degrees and 10 to 35 units at 85 degrees, according to ASTM D 523, an eggshell finish.
- D. Gloss Level 4: 20 to 35 units at 60 degrees and not less than 35 units at 85 degrees, according to ASTM D 523, a satin-like finish.
- E. Gloss Level 5: 35 to 70 units at 60 degrees, according to ASTM D 523, a semi-gloss finish.
- F. Gloss Level 6: 70 to 85 units at 60 degrees, according to ASTM D 523, a gloss finish.

1.3 ACTION SUBMITTALS

- A. Product Data: For each type of product. Include preparation requirements and application instructions.
- B. Samples for Initial Selection: For each type of topcoat product.
- C. Samples for Verification: For each type of paint system and each color and gloss of topcoat.
 - 1. Submit Samples on rigid backing, 8 inches square.
 - 2. Step coats on Samples to show each coat required for system.
 - 3. Label each coat of each Sample.
 - 4. Label each Sample for location and application area.
- D. Product List: For each product indicated, include the following:
 - 1. Cross-reference to paint system and locations of application areas. Use same designations indicated on Drawings and in schedules.
 - 2. Printout of current "MPI Approved Products List" for each product category specified in Part 2, with the proposed product highlighted.
 - 3. VOC content.

Weedsport Addition to Maintenance Section and Roof Replacement, MP 304.2

1.4 CLOSEOUT SUBMITTALS

- A. Coating Maintenance Manual: Provide coating maintenance manual including area summary with finish schedule, area detail designating location where each product/color/finish was used, product data pages, material safety data sheets, care and cleaning instructions, touch-up procedures, and color samples of each color and finish used.

1.5 QUALITY ASSURANCE

- A. Mockups: Apply mockups of each paint system indicated and each color and finish selected to verify preliminary selections made under Sample submittals and to demonstrate aesthetic effects and set quality standards for materials and execution.
1. Architect will select one surface to represent surfaces and conditions for application of each paint system specified in Part 3.
 - a. Vertical and Horizontal Surfaces: Provide samples of at least 100 sq. ft..
 - b. Other Items: Architect will designate items or areas required.
 2. Final approval of color selections will be based on mockups.
 - a. If preliminary color selections are not approved, apply additional mockups of additional colors selected by Architect at no added cost to Owner.
 3. Approval of mockups does not constitute approval of deviations from the Contract Documents contained in mockups unless Architect specifically approves such deviations in writing.
 4. Subject to compliance with requirements, approved mockups may become part of the completed Work if undisturbed at time of Substantial Completion.

1.6 DELIVERY, STORAGE, AND HANDLING

- A. Delivery and Handling: Deliver products to Project site in an undamaged condition in manufacturer's original sealed containers, complete with labels and instructions for handling, storing, unpacking, protecting, and installing. Packaging shall bear the manufacture's label with the following information:
1. Product name and type (description).
 2. Batch date.
 3. Color number.
 4. VOC content.
 5. Environmental handling requirements.
 6. Surface preparation requirements.
 7. Application instructions.
- B. Store materials not in use in tightly covered containers in well-ventilated areas with ambient temperatures continuously maintained at not less than 45 deg F.
1. Maintain containers in clean condition, free of foreign materials and residue.
 2. Remove rags and waste from storage areas daily.

Weedsport Addition to Maintenance Section and Roof Replacement, MP 304.2

1.7 FIELD CONDITIONS

- A. Apply paints only when temperature of surfaces to be painted and ambient air temperatures are between 50 and 95 deg F.
- B. Do not apply paints in snow, rain, fog, or mist; when relative humidity exceeds 85 percent; at temperatures less than 5 deg F above the dew point; or to damp or wet surfaces.

PART 2 - PRODUCTS**2.1 MANUFACTURERS**

- A. Basis-of-Design Product: Subject to compliance with requirements, provide Sherwin-Williams Company products indicated or comparable product from one of the following:
 - 1. Benjamin Moore & Co.
 - 2. PPG Architectural Finishes, Inc.

2.2 PAINT, GENERAL

- A. MPI Standards: Provide products that comply with MPI standards indicated and that are listed in its "MPI Approved Products List."
- B. Material Compatibility:
 - 1. Provide materials for use within each paint system that are compatible with one another and substrates indicated, under conditions of service and application as demonstrated by manufacturer, based on testing and field experience.
 - 2. For each coat in a paint system, provide products recommended in writing by manufacturers of topcoat for use in paint system and on substrate indicated.
- C. VOC Content: Provide materials that comply with VOC limits of authorities having jurisdiction.
- D. Colors: As selected by Architect from manufacturer's full range

2.3 SOURCE QUALITY CONTROL

- A. Testing of Paint Materials: Owner reserves the right to invoke the following procedure:
 - 1. Owner will engage the services of a qualified testing agency to sample paint materials. Contractor will be notified in advance and may be present when samples are taken. If paint materials have already been delivered to Project site, samples may be taken at Project site. Samples will be identified, sealed, and certified by testing agency.
 - 2. Testing agency will perform tests for compliance with product requirements.
 - 3. Owner may direct Contractor to stop applying paints if test results show materials being used do not comply with product requirements. Contractor shall remove noncomplying paint materials from Project site, pay for testing, and repaint surfaces painted with rejected materials. Contractor will be required to remove rejected materials from previously painted surfaces if, on repainting with complying materials, the two paints are incompatible.

PART 3 - EXECUTION

3.1 EXAMINATION

- A. Examine substrates and conditions, with Applicator present, for compliance with requirements for maximum moisture content and other conditions affecting performance of the Work. Verify suitability of substrates, including surface conditions and compatibility with existing finishes and primers. Where acceptability of substrate conditions is in question, apply samples and perform in-situ testing to verify compatibility, adhesion, and film integrity of new paint application.
1. Report, in writing, conditions that may affect application, appearance, or performance of paint.
- B. Substrate Conditions:
1. Maximum Moisture Content of Substrates: When measured with an electronic moisture meter as follows:
 - a. Concrete: 12 percent.
 - b. Masonry (Clay and CMU): 12 percent.
 - c. Wood: 15 percent.
 - d. Portland Cement Plaster: 12 percent.
 2. Portland Cement Plaster Substrates: Verify that plaster is fully cured.
- C. Proceed with coating application only after unsatisfactory conditions have been corrected; application of coating indicates acceptance of surfaces and conditions.
1. Application of coating indicates acceptance of surfaces and conditions.

3.2 PREPARATION

- A. Comply with manufacturer's written instructions and recommendations in "MPI Manual" applicable to substrates and paint systems indicated.
- B. Remove hardware, covers, plates, and similar items already in place that are removable and are not to be painted. If removal is impractical or impossible because of size or weight of item, provide surface-applied protection before surface preparation and painting.
1. After completing painting operations, use workers skilled in the trades involved to reinstall items that were removed. Remove surface-applied protection.
- C. Clean substrates of substances that could impair bond of paints, including dust, dirt, oil, grease, and incompatible paints and encapsulants.
1. Remove incompatible primers and reprime substrate with compatible primers or apply tie coat as required to produce paint systems indicated.
- D. Concrete Substrates: Remove release agents, curing compounds, efflorescence, and chalk. Do not paint surfaces if moisture content or alkalinity of surfaces to be painted exceeds that permitted in manufacturer's written instructions.

Weedsport Addition to Maintenance Section and Roof Replacement, MP 304.2

- E. Masonry Substrates: Remove efflorescence and chalk. Do not paint surfaces if moisture content or alkalinity of surfaces or mortar joints exceeds that permitted in manufacturer's written instructions.
- F. Shop-Primed Steel Substrates: Clean field welds, bolted connections, and abraded areas of shop paint, and paint exposed areas with the same material as used for shop priming to comply with SSPC-PA 1 for touching up shop-primed surfaces.
- G. Galvanized-Metal Substrates: Remove grease and oil residue from galvanized sheet metal by mechanical methods to produce clean, lightly etched surfaces that promote adhesion of subsequently applied paints.
- H. Aluminum Substrates: Remove loose surface oxidation.
- I. Wood Substrates:
 - 1. Scrape and clean knots. Before applying primer, apply coat of knot sealer recommended in writing by topcoat manufacturer for exterior use in paint system indicated.
 - 2. Sand surfaces that will be exposed to view, and dust off.
 - 3. Prime edges, ends, faces, undersides, and backsides of wood.
 - 4. After priming, fill holes and imperfections in the finish surfaces with putty or plastic wood filler. Sand smooth when dried.
- J. Plastic Trim Fabrication Substrates: Remove dust, dirt, and other foreign material that might impair bond of paints to substrates.

3.3 APPLICATION

- A. Apply paints according to manufacturer's written instructions and recommendations in "MPI Manual."
 - 1. Use applicators and techniques suited for paint and substrate indicated.
 - 2. Paint surfaces behind movable items same as similar exposed surfaces. Before final installation, paint surfaces behind permanently fixed items with prime coat only.
 - 3. Paint both sides and edges of exterior doors and entire exposed surface of exterior door frames.
 - 4. Paint entire exposed surface of window frames and sashes.
 - 5. Do not paint over labels of independent testing agencies or equipment name, identification, performance rating, or nomenclature plates.
 - 6. Primers specified in painting schedules may be omitted on items that are factory primed or factory finished if acceptable to topcoat manufacturers.
- B. Tint undercoats same color as topcoat, but tint each undercoat a lighter shade to facilitate identification of each coat if multiple coats of same material are to be applied. Provide sufficient difference in shade of undercoats to distinguish each separate coat.
- C. If undercoats or other conditions show through topcoat, apply additional coats until cured film has a uniform paint finish, color, and appearance.
- D. Apply paints to produce surface films without cloudiness, spotting, holidays, laps, brush marks, roller tracking, runs, sags, ropiness, or other surface imperfections. Cut in sharp lines and color breaks.
- E. Painting Fire Suppression, Plumbing, HVAC, Electrical, Communication, and Electronic Safety and Security Work:

Weedsport Addition to Maintenance Section and Roof Replacement, MP 304.2

1. Paint the following work where exposed to view:
 - a. Equipment, including panelboards.
 - b. Uninsulated metal piping.
 - c. Uninsulated plastic piping.
 - d. Pipe hangers and supports.
 - e. Metal conduit.
 - f. Plastic conduit.
 - g. Tanks that do not have factory-applied final finishes.

3.4 FIELD QUALITY CONTROL

- A. Dry Film Thickness Testing: Owner may engage the services of a qualified testing and inspecting agency to inspect and test paint for dry film thickness.
 1. Contractor shall touch up and restore painted surfaces damaged by testing.
 2. If test results show that dry film thickness of applied paint does not comply with paint manufacturer's written recommendations, Contractor shall pay for testing and apply additional coats as needed to provide dry film thickness that complies with paint manufacturer's written recommendations.

3.5 CLEANING AND PROTECTION

- A. At end of each workday, remove rubbish, empty cans, rags, and other discarded materials from Project site.
- B. After completing paint application, clean spattered surfaces. Remove spattered paints by washing, scraping, or other methods. Do not scratch or damage adjacent finished surfaces.
- C. Protect work of other trades against damage from paint application. Correct damage to work of other trades by cleaning, repairing, replacing, and refinishing, as approved by Architect, and leave in an undamaged condition.
- D. At completion of construction activities of other trades, touch up and restore damaged or defaced painted surfaces.

3.6 EXTERIOR PAINTING SCHEDULE

- A. Ferrous Metal, Galvanized-Metal, and Aluminum Substrates:
 1. Water-Based Light Industrial Coating System:
 - a. Prime Coat: Primer, water-based, anti-corrosive for metal[, **MPI #107**]: S-W Pro Industrial Pro-Cryl Universal Primer, B66-310 Series, 5.0 to 10.0 mils wet, 2.0 to 4.0 mils dry.
 - b. Prime Coat: Shop primer specified in Section where substrate is specified.
 - c. Intermediate Coat: Light industrial coating, exterior, water based, matching topcoat.
 - d. Topcoat: Light industrial coating, exterior, water based, semi-gloss, (Gloss Level 5), **MPI #163**: S-W Pro Industrial Acrylic Semi-Gloss Coating, B66-650 Series, at 2.5 to 4.0 mils dry, per coat.

END OF SECTION 099113

SECTION 099123 - INTERIOR PAINTING

PART 1 - GENERAL

1.1 SUMMARY

- A. Section includes surface preparation and the application of paint systems on interior substrates.
- B. Related Requirements:
 - 1. Section 099600 "High-Performance Coatings" for high-performance and special-use coatings.

1.2 DEFINITIONS

- A. Gloss Level 1: Not more than 5 units at 60 degrees and 10 units at 85 degrees, according to ASTM D 523, a matte flat finish.
- B. Gloss Level 2: Not more than 10 units at 60 degrees and 10 to 35 units at 85 degrees, according to ASTM D 523, a high-side sheen flat, velvet-like finish.
- C. Gloss Level 3: 10 to 25 units at 60 degrees and 10 to 35 units at 85 degrees, according to ASTM D 523, an eggshell finish.
- D. Gloss Level 4: 20 to 35 units at 60 degrees and not less than 35 units at 85 degrees, according to ASTM D 523, a satin-like finish.
- E. Gloss Level 5: 35 to 70 units at 60 degrees, according to ASTM D 523, a semi-gloss finish.
- F. Gloss Level 6: 70 to 85 units at 60 degrees, according to ASTM D 523, a gloss finish.

1.3 ACTION SUBMITTALS

- A. Product Data: For each type of product. Include preparation requirements and application instructions.

1.4 CLOSEOUT SUBMITTALS

- A. Coating Maintenance Manual: Provide coating maintenance manual including area summary with finish schedule, area detail designating location where each product/color/finish was used, product data pages, material safety data sheets, care and cleaning instructions, touch-up procedures, and color samples of each color and finish used.

1.5 MAINTENANCE MATERIAL SUBMITTALS

- A. Furnish extra materials, from the same product run, that match products installed and that are packaged with protective covering for storage and identified with labels describing contents.
 - 1. Paint: 5 percent, but not less than 1 gal. of each material and color applied.

1.6 DELIVERY, STORAGE, AND HANDLING

- A. Delivery and Handling: Deliver products to Project site in an undamaged condition in manufacturer's original sealed containers, complete with labels and instructions for handling,

Weedspport Addition to Maintenance Section and Roof Replacement, MP 304.2

storing, unpacking, protecting, and installing. Packaging shall bear the manufacturer's label with the following information:

1. Product name and type (description).
 2. Batch date.
 3. Color number.
 4. VOC content.
 5. Environmental handling requirements.
 6. Surface preparation requirements.
 7. Application instructions.
- B. Store materials not in use in tightly covered containers in well-ventilated areas with ambient temperatures continuously maintained at not less than 45 deg F.
1. Maintain containers in clean condition, free of foreign materials and residue.
 2. Remove rags and waste from storage areas daily.

1.7 FIELD CONDITIONS

- A. Apply paints only when temperature of surfaces to be painted and ambient air temperatures are between 50 and 95 deg F.
- B. Do not apply paints when relative humidity exceeds 85 percent; at temperatures less than 5 deg F above the dew point; or to damp or wet surfaces.
- C. Lead Paint: Lead paint is likely to be present in buildings and structures to be painted.
1. Use Lead Safe Work Practices in accordance with US Dept.of Housing and Urban Development. All employees working with Lead based paint Materials shall have HUD approved training.
 2. Do not disturb lead paint or items suspected of containing hazardous materials except under procedures specified.
 3. Perform preparation for painting of substrates known to include lead paint in accordance with EPA Renovation, Repair and Painting Rule and additional requirements of authorities having jurisdiction.

PART 2 - PRODUCTS

2.1 MANUFACTURERS

- A. Basis-of-Design Product: Subject to compliance with requirements, provide Sherwin-Williams Company products indicated or comparable product from one of the following:
1. Benjamin Moore & Co.
 2. Devoe
 3. Glidden Professional, Division of PPG Architectural Finishes, Inc.
 4. Pratt & Lambert.
- B. Colors: As selected by Owner. Expected number of colors is indicated in Room finish schedule on Drawing A701.

2.2 PAINT, GENERAL

- A. MPI Standards: Provide products that comply with MPI standards indicated and that are listed in its "MPI Approved Products List."
- B. Material Compatibility:
 - 1. Provide materials for use within each paint system that are compatible with one another and substrates indicated, under conditions of service and application as demonstrated by manufacturer, based on testing and field experience.
 - 2. For each coat in a paint system, provide products recommended in writing by manufacturers of topcoat for use in paint system and on substrate indicated.
- C. VOC Content: Products shall comply with VOC limits of authorities having jurisdiction.
 - 1. Flat Paints and Coatings: 50 g/L.
 - 2. Nonflat Paints and Coatings: 150 g/L.
 - 3. Dry-Fog Coatings: 400 g/L.
 - 4. Primers, Sealers, and Undercoaters: 200 g/L.
 - 5. Anticorrosive and Antirust Paints Applied to Ferrous Metals: 250 g/L.
 - 6. Zinc-Rich Industrial Maintenance Primers: 340 g/L.
 - 7. Pretreatment Wash Primers: 420 g/L.
 - 8. Floor Coatings: 100 g/L.
 - 9. Shellacs, Clear: 730 g/L.
 - 10. Shellacs, Pigmented: 550 g/L.
- D. Low-Emitting Materials: Interior paints and coatings shall comply with the testing and product requirements of the California Department of Health Services' "Standard Practice for the Testing of Volatile Organic Emissions from Various Sources Using Small-Scale Environmental Chambers."

2.3 SOURCE QUALITY CONTROL

- A. Testing of Paint Materials: Owner reserves the right to invoke the following procedure:
 - 1. Owner may engage the services of a qualified testing agency to sample paint materials. Contractor will be notified in advance and may be present when samples are taken. If paint materials have already been delivered to Project site, samples may be taken at Project site. Samples will be identified, sealed, and certified by testing agency.
 - 2. Testing agency may perform tests for compliance with product requirements.
 - 3. Owner may direct Contractor to stop applying coatings if test results show materials being used do not comply with product requirements. Contractor shall remove noncomplying paint materials from Project site, pay for testing, and repaint surfaces painted with rejected materials. Contractor will be required to remove rejected materials from previously painted surfaces if, on repainting with complying materials, the two paints are incompatible.

PART 3 - EXECUTION

3.1 EXAMINATION

- A. Examine substrates and conditions, with Applicator present, for compliance with requirements for maximum moisture content and other conditions affecting performance of the Work. Verify suitability of substrates, including surface conditions and compatibility with existing finishes and primers. Where acceptability of substrate conditions is in question, apply samples and perform in-situ testing to verify compatibility, adhesion, and film integrity of new paint application.
1. Report, in writing, conditions that may affect application, appearance, or performance of paint.
- B. Substrate Conditions:
1. Maximum Moisture Content of Substrates: When measured with an electronic moisture meter as follows:
 - a. Concrete: 12 percent.
 - b. Masonry (Clay and CMU): 12 percent.
 - c. Gypsum Board: 12 percent.
 - d. Plaster: 12 percent.
 2. Gypsum Board Substrates: Verify that finishing compound is sanded smooth.
 3. Plaster Substrates: Verify that plaster is fully cured.
 4. Spray-Textured Ceiling Substrates: Verify that surfaces are dry.
- C. Proceed with coating application only after unsatisfactory conditions have been corrected; application of coating indicates acceptance of surfaces and conditions.
1. Application of coating indicates acceptance of surfaces and conditions.

3.2 PREPARATION

- A. Comply with manufacturer's written instructions and recommendations in "MPI Manual" applicable to substrates indicated.
- B. Remove hardware, covers, plates, and similar items already in place that are removable and are not to be painted. If removal is impractical or impossible because of size or weight of item, provide surface-applied protection before surface preparation and painting.
1. After completing painting operations, use workers skilled in the trades involved to reinstall items that were removed. Remove surface-applied protection if any.
- C. Clean substrates of substances that could impair bond of paints, including dust, dirt, oil, grease, and incompatible paints and encapsulants.
1. Remove incompatible primers and reprime substrate with compatible primers or apply tie coat as required to produce paint systems indicated.
- D. Concrete Substrates: Remove release agents, curing compounds, efflorescence, and chalk. Do not paint surfaces if moisture content or alkalinity of surfaces to be painted exceeds that permitted in manufacturer's written instructions.

Weedsport Addition to Maintenance Section and Roof Replacement, MP 304.2

1. Concrete Floors: Remove oil, dust, grease, dirt, and other foreign materials. Comply with SSPC-SP-13/NACE 6 or ICRI 03732.
- E. Masonry Substrates: Remove efflorescence and chalk. Do not paint surfaces if moisture content or alkalinity of surfaces or mortar joints exceed that permitted in manufacturer's written instructions.
- F. Steel Substrates: Remove rust, loose mill scale, and shop primer, if any. Clean using methods recommended in writing by paint manufacturer.
- G. Shop-Primed Steel Substrates: Clean field welds, bolted connections, and abraded areas of shop paint, and paint exposed areas with the same material as used for shop priming to comply with SSPC-PA 1 for touching up shop-primed surfaces.
- H. Galvanized-Metal Substrates: Remove grease and oil residue from galvanized sheet metal fabricated from coil stock by mechanical methods to produce clean, lightly etched surfaces that promote adhesion of subsequently applied paints.
- I. Aluminum Substrates: Remove loose surface oxidation.

3.3 APPLICATION

- A. Apply paints according to manufacturer's written instructions and to recommendations in "MPI Manual."
 1. Use applicators and techniques suited for paint and substrate indicated.
 2. Paint surfaces behind movable equipment and furniture same as similar exposed surfaces. Before final installation, paint surfaces behind permanently fixed equipment or furniture with prime coat only.
 3. Paint front and backsides of access panels, removable or hinged covers, and similar hinged items to match exposed surfaces.
 4. Do not paint over labels of independent testing agencies or equipment name, identification, performance rating, or nomenclature plates.
 5. Primers specified in painting schedules may be omitted on items that are factory primed or factory finished if acceptable to topcoat manufacturers.
- B. Tint each undercoat a lighter shade to facilitate identification of each coat if multiple coats of same material are to be applied. Tint undercoats to match color of topcoat, but provide sufficient difference in shade of undercoats to distinguish each separate coat.
- C. If undercoats or other conditions show through topcoat, apply additional coats until cured film has a uniform paint finish, color, and appearance.
- D. Apply paints to produce surface films without cloudiness, spotting, holidays, laps, brush marks, roller tracking, runs, sags, ropiness, or other surface imperfections. Cut in sharp lines and color breaks.
- E. Painting Fire Suppression, Plumbing, HVAC, Electrical, Communication, and Electronic Safety and Security Work:
 1. Paint the following work where exposed in equipment rooms:
 - a. Uninsulated metal piping.
 - b. Uninsulated plastic piping.
 - c. Pipe hangers and supports.
 - d. Metal conduit.

- e. Plastic conduit.
2. Paint the following work where exposed in occupied spaces:
 - a. Uninsulated metal piping.
 - b. Uninsulated plastic piping.
 - c. Pipe hangers and supports.
 - d. Metal conduit.
 - e. Plastic conduit.

3.4 FIELD QUALITY CONTROL

- A. Dry Film Thickness Testing: Owner may engage the services of a qualified testing and inspecting agency to inspect and test paint for dry film thickness.
 1. Contractor shall touch up and restore painted surfaces damaged by testing.
 2. If test results show that dry film thickness of applied paint does not comply with paint manufacturer's written recommendations, Contractor shall pay for testing and apply additional coats as needed to provide dry film thickness that complies with paint manufacturer's written recommendations.

3.5 CLEANING AND PROTECTION

- A. At end of each workday, remove rubbish, empty cans, rags, and other discarded materials from Project site.
- B. After completing paint application, clean spattered surfaces. Remove spattered paints by washing, scraping, or other methods. Do not scratch or damage adjacent finished surfaces.
- C. Protect work of other trades against damage from paint application. Correct damage to work of other trades by cleaning, repairing, replacing, and refinishing, as approved by Architect, and leave in an undamaged condition.
- D. At completion of construction activities of other trades, touch up and restore damaged or defaced painted surfaces.

3.6 INTERIOR PAINTING SCHEDULE

- A. Concrete Substrates, Nontraffic Surfaces:
 1. Latex System:
 - a. Prime Coat: Primer sealer, latex, interior, MPI #3: S-W Loxon Concrete & Masonry Primer Sealer, A24W8300, at 8.0 mils wet, 3.2 mils dry.
 - b. Intermediate Coat: Latex, interior, matching topcoat.
 - c. Topcoat: Latex, interior, semi-gloss, (Gloss Level 4), MPI #43 X-Green: S-W ProMar 200 Zero VOC Latex Semi-Gloss, B31-2600 Series, at 4.0 mils wet, 1.6 mils dry, per coat.
- B. CMU Substrates:
 1. Latex System:

Weedsport Addition to Maintenance Section and Roof Replacement, MP 304.2

- a. Block Filler: Block filler, latex, interior/exterior, MPI #4 X-Green: S-W PrepRite Block Filler, B25W25, at 100 to 200 sq. ft. per gal.
 - b. Intermediate Coat: Latex, interior, matching topcoat.
 - c. Topcoat: Latex, interior, semi-gloss, (Gloss Level 4), MPI #43 X-Green: S-W ProMar 200 Zero VOC Latex Semi-Gloss, B31-2600 Series, at 4.0 mils wet, 1.6 mils dry, per coat.
- C. Metal Substrates (Aluminum, Steel, Galvanized Steel):
1. Latex System:
 - a. Prime Coat: Primer, rust-inhibitive, water based, MPI #107: S-W Pro Industrial Pro-Cryl Universal Primer, B66-310 Series, at 5.0 to 10 mils wet, 2.0 to 4.0 mils dry.
 - b. Intermediate Coat: Water-based acrylic, interior, matching topcoat.
 - c. Topcoat: Water-based acrylic, semi-gloss, (Gloss Level 5), MPI #147 X-Green: S-W Pro Industrial Acrylic Semi-Gloss Coating, B66-650 Series, at 2.5 to 4.0 mils dry, per coat.
 2. Water-Based Dry-Fall System:
 - a. Top Coat: Dry-fall latex, eggshell, MPI #131/155: S-W Pro Industrial Waterborne Acrylic DryFall Eg-Shel, B42-2 Series, at 6.0 mils wet, 1.9 mils dry.
- D. Gypsum Board and Plaster Substrates:
1. Latex System:
 - a. Prime Coat: Primer, latex, interior, MPI #149 X-Green: S-W ProMar 200 Zero VOC Latex Primer, B28W2600, at 4.0 mils wet, 1.5 mils dry.
 - b. Intermediate Coat: Latex, interior, matching topcoat.
 - c. Topcoat: Latex, interior, eggshell, (Gloss Level 3), MPI #52 X-Green/#145 X-Green: S-W ProMar 200 Zero VOC Latex Eg-Shel, B20-2600 Series, at 4.0 mils wet, 1.7 mils dry, per coat.

END OF SECTION 099123

SECTION 099600 - HIGH-PERFORMANCE COATINGS

PART 1 - GENERAL

1.1 SUMMARY

- A. Section includes surface preparation and application of high-performance coating systems.
- B. Related Requirements:
 - 1. Section 099113 "Exterior Painting" for special-use coatings and general field painting.
 - 2. Section 099123 "Interior Painting" for special-use coatings and general field painting.

1.2 DEFINITIONS

- A. Gloss Level 3: 10 to 25 units at 60 degrees and 10 to 35 units at 85 degrees, according to ASTM D 523, an eggshell finish.
- B. Gloss Level 5: 35 to 70 units at 60 degrees, according to ASTM D 523, a semi-gloss finish.
- C. Gloss Level 6: 70 to 85 units at 60 degrees, according to ASTM D 523, a gloss finish.
- D. Gloss Level 7: More than 85 units at 60 degrees, according to ASTM D 523, a high-gloss finish.

1.3 ACTION SUBMITTALS

- A. Product Data: For each type of product indicated. Include preparation requirements and application instructions.
- B. Product List: For each product indicated, include the following:
 - 1. Cross-reference to paint system and locations of application areas. Use same designations indicated on Drawings and in schedules.
 - 2. Printout of current "MPI Approved Products List" for each coating system specified in Part 3, with the proposed product highlighted.
 - 3. VOC content.

1.4 CLOSEOUT SUBMITTALS

- A. Coating Maintenance Manual: Provide coating maintenance manual including area summary with finish schedule, area detail designating location where each product/color/finish was used, product data pages, material safety data sheets, care and cleaning instructions, touch-up procedures, and color samples of each color and finish used.

1.5 DELIVERY, STORAGE, AND HANDLING

- A. Delivery and Handling: Deliver products to Project site in an undamaged condition in manufacturer's original sealed containers, complete with labels and instructions for handling, storing, unpacking, protecting, and installing. Packaging shall bear the manufacture's label with the following information:
 - 1. Product name and type (description).
 - 2. Batch date.
 - 3. Color number.
 - 4. VOC content.
 - 5. Environmental handling requirements.

Weedsport Addition to Maintenance Section and Roof Replacement, MP 304.2

6. Surface preparation requirements.
 7. Application instructions.
- B. Store materials not in use in tightly covered containers in well-ventilated areas with ambient temperatures continuously maintained at not less than 45 deg F.
1. Maintain containers in clean condition, free of foreign materials and residue.
 2. Remove rags and waste from storage areas daily.

1.6 FIELD CONDITIONS

- A. Apply coatings only when temperature of surfaces to be coated and surrounding air temperatures are between 50 and 95 deg F.
- B. Do not apply coatings when relative humidity exceeds 85 percent; at temperatures less than 5 deg F above the dew point; or to damp or wet surfaces.
- C. Do not apply exterior coatings in snow, rain, fog, or mist.

PART 2 - PRODUCTS**2.1 MANUFACTURERS**

- A. Basis-of-Design Product: Subject to compliance with requirements, provide The Sherwin-Williams Company; products indicated or comparable product from one of the following:
1. Benjamin Moore & Co.
 2. PPG Architectural Finishes, Inc.
 3. Tnemec Inc.
- B. Source Limitations: Obtain paint materials from single source from single listed manufacturer.
1. Manufacturer's designations listed on a separate color schedule are for color reference only and do not indicate prior approval.

2.2 HIGH-PERFORMANCE COATINGS, GENERAL

- A. MPI Standards: Provide products that comply with MPI standards indicated and are listed in "MPI Approved Products List."
- B. Material Compatibility:
1. Provide materials for use within each coating system that are compatible with one another and substrates indicated, under conditions of service and application as demonstrated by manufacturer, based on testing and field experience.
 2. For each coat in a coating system, provide products recommended in writing by manufacturers of topcoat for use in coating system and on substrate indicated.
 3. Provide products of same manufacturer for each coat in a coating system.
- C. VOC Content: Products shall comply with VOC limits of authorities having jurisdiction.
1. Flat Paints and Coatings: 50 g/L.
 2. Nonflat Paints and Coatings: 150 g/L.
 3. Primers, Sealers, and Undercoaters: 200 g/L.
 4. Anti-Corrosive and Anti-Rust Paints Applied to Ferrous Metals: 250 g/L.

Weedsport Addition to Maintenance Section and Roof Replacement, MP 304.2

5. Zinc-Rich Industrial Maintenance Primers: 340 g/L.
6. Pre-Treatment Wash Primers: 420 g/L.
7. Floor Coatings: 100 g/L.
8. Shellacs, Clear: 730 g/L.
9. Shellacs, Pigmented: 550 g/L.

D. Colors: As selected by owner.

2.3 SOURCE QUALITY CONTROL

A. Testing of Coating Materials: Owner reserves the right to invoke the following procedure:

1. Owner may engage the services of a qualified testing agency to sample coating materials. Contractor will be notified in advance and may be present when samples are taken. If coating materials have already been delivered to Project site, samples may be taken at Project site. Samples will be identified, sealed, and certified by testing agency.
2. Testing agency may perform tests for compliance with product requirements.
3. Owner may direct Contractor to stop applying paints if test results show materials being used do not comply with product requirements. Contractor shall remove noncomplying coating materials from Project site, pay for testing, and recoat surfaces coated with rejected materials. Contractor will be required to remove rejected materials from previously coated surfaces if, on recoating with complying materials, the two coatings are incompatible.

PART 3 - EXECUTION

3.1 EXAMINATION

- A. Examine substrates and conditions, with Applicator present, for compliance with requirements for maximum moisture content and other conditions affecting performance of the Work. Verify suitability of substrates, including surface conditions and compatibility with existing finishes and primers. Where acceptability of substrate conditions is in question, apply samples and perform in-situ testing to verify compatibility, adhesion, and film integrity of new paint application.
1. Report in writing conditions that may affect application, appearance, or performance of paint.
- B. Substrate Conditions:
1. Maximum Moisture Content of Substrates: When measured with an electronic moisture meter as follows:
 - a. Concrete: 12 percent.
 - b. Concrete Masonry: 12 percent.
 - c. Gypsum Board: 12 percent.
 2. Gypsum Board Substrates: Verify that finishing compound is sanded smooth.
 3. Plaster Substrates: Verify that plaster is fully cured.
- C. Verify suitability of substrates, including surface conditions and compatibility with existing finishes and primers.
- D. Proceed with coating application only after unsatisfactory conditions have been corrected; application of coating indicates acceptance of surfaces and conditions.

Weedsport Addition to Maintenance Section and Roof Replacement, MP 304.2

3.2 PREPARATION

- A. Comply with manufacturer's written instructions and recommendations in "MPI Architectural Painting Specification Manual" applicable to substrates indicated.
- B. Remove hardware, covers, plates, and similar items already in place that are removable and are not to be painted. If removal is impractical or impossible because of size or weight of item, provide surface-applied protection before surface preparation and painting.
 - 1. After completing painting operations, use workers skilled in the trades involved to reinstall items that were removed. Remove surface-applied protection.
- C. Clean substrates of substances that could impair bond of coatings, including dust, dirt, oil, grease, and incompatible paints and encapsulants.
 - 1. Remove incompatible primers and reprime substrate with compatible primers or apply tie coat as required to produce coating systems indicated.
- D. Concrete Substrates: Remove release agents, curing compounds, efflorescence, and chalk. Do not coat surfaces if moisture content or alkalinity of surfaces to be coated exceeds that permitted in manufacturer's written instructions.
- E. Masonry Substrates: Remove efflorescence and chalk. Do not coat surfaces if moisture content or alkalinity of surfaces or if alkalinity of mortar joints exceed that permitted in manufacturer's written instructions.
- F. Steel Substrates: Remove rust, loose mill scale, and shop primer if any. Clean using methods recommended in writing by paint manufacturer.
- G. Shop-Primed Steel Substrates: Clean field welds, bolted connections, and abraded areas of shop paint, and paint exposed areas with the same material as used for shop priming to comply with SSPC-PA 1 for touching up shop-primed surfaces.
- H. Galvanized-Metal Substrates: Remove grease and oil residue from galvanized sheet metal by mechanical methods to produce clean, lightly etched surfaces that promote adhesion of subsequently applied coatings.

3.3 APPLICATION

- A. Apply high-performance coatings according to manufacturer's written instructions and recommendations in "MPI Architectural Painting Specification Manual."
 - 1. Use applicators and techniques suited for coating and substrate indicated.
 - 2. Coat surfaces behind movable equipment and furniture same as similar exposed surfaces. Before final installation, coat surfaces behind permanently fixed equipment or furniture with prime coat only.
 - 3. Coat back sides of access panels, removable or hinged covers, and similar hinged items to match exposed surfaces.
 - 4. Do not apply coatings over labels of independent testing agencies or equipment name, identification, performance rating, or nomenclature plates.
- B. Tint each undercoat a lighter shade to facilitate identification of each coat if multiple coats of the same material are to be applied. Tint undercoats to match color of finish coat, but provide sufficient difference in shade of undercoats to distinguish each separate coat.

Weedsport Addition to Maintenance Section and Roof Replacement, MP 304.2

- C. If undercoats or other conditions show through final coat, apply additional coats until cured film has a uniform coating finish, color, and appearance.
- D. Apply coatings to produce surface films without cloudiness, spotting, holidays, laps, brush marks, runs, sags, ropiness, or other surface imperfections. Produce sharp glass lines and color breaks.

3.4 FIELD QUALITY CONTROL

- A. Dry Film Thickness Testing: Owner will engage the services of a qualified testing and inspecting agency to inspect and test coatings for dry film thickness.
 - 1. Contractor shall touch up and restore coated surfaces damaged by testing.
 - 2. If test results show that dry film thickness of applied coating does not comply with coating manufacturer's written recommendations, Contractor shall pay for testing and apply additional coats as needed to provide dry film thickness that complies with coating manufacturer's written recommendations.

3.5 CLEANING AND PROTECTION

- A. At end of each workday, remove rubbish, empty cans, rags, and other discarded materials from Project site.
- B. After completing coating application, clean spattered surfaces. Remove spattered coatings by washing, scraping, or other methods. Do not scratch or damage adjacent finished surfaces.
- C. Protect work of other trades against damage from coating operation. Correct damage by cleaning, repairing, replacing, and recoating, as approved by Architect, and leave in an undamaged condition.
- D. At completion of construction activities of other trades, touch up and restore damaged or defaced coated surfaces.

3.6 INTERIOR HIGH-PERFORMANCE COATING SCHEDULE

- A. CMU Substrates:
 - 1. Epoxy-Modified Latex System:
 - a. Block Filler: Block filler, latex, interior/exterior, MPI #4: S-W PrepRite Interior/Exterior Block Filler, B25 Series, at 8 mils dry, per coat.
 - b. Intermediate Coat: Epoxy-modified latex, interior, gloss, matching topcoat.
 - c. Topcoat: Epoxy-modified latex, interior, eggshell, (Gloss Level 3), MPI #254/MPI #254X-Green: S-W Pro Industrial Waterbased Catalyzed Epoxy Eggshell, B73-300 Series, at 2.0 to 4.0 mils dry, per coat.
- B. Steel Substrates:
 - 1. Epoxy-Modified Latex System:
 - a. Prime Coat: Primer, rust-inhibitive, water based, MPI #107: S-W Pro-Cryl Universal Primer, B66-310 Series, at 2.0 to 4.0 mils dry, per coat.
 - b. Intermediate Coat: Epoxy-modified latex, interior, gloss matching topcoat.
 - c. Topcoat: Epoxy-modified latex, interior, gloss, (Gloss Level 6), MPI #115/MPI #115X-Green: S-W Pro Industrial Waterbased Catalyzed Epoxy Gloss, B73-300 Series, at 2.0 to 4.0 mils dry, per coat.

Weedsport Addition to Maintenance Section and Roof Replacement, MP 304.2

C. Gypsum and Board Plaster Substrates:

1. Epoxy-Modified Latex System:

- a. Prime Coat: Primer sealer, latex, interior, MPI #50: S-W ProMar 200 Zero VOC Interior Latex Primer, B28 Series, at 1.0 mils dry, per coat.
- b. Intermediate Coat: Epoxy-modified latex, interior, matching topcoat.
- c. Topcoat: Epoxy-modified latex, interior, eggshell, (Gloss Level 3), MPI #115/#115X-Green: S-W Pro Industrial Waterbased Catalyzed Epoxy Eggshell, B73-360 Series, at 2.0 to 4.0 mils dry, per coat.

END OF SECTION 099600

ITEM 627.0010 25**SPECIALTIES****1. DESCRIPTION:**

- 1.01 Furnish all labor, materials, equipment and services necessary to complete the work as indicated on the Contract Plans and the attached Specification Summary.
- 1.04 All work shall conform to the requirements specified in Part 1 – General, of the Sections listed.

2. MATERIALS:

- 2.01 The materials shall be as specified in Part 2 – Products, of the Sections listed.

3. CONSTRUCTION DETAILS:

- 3.01 The construction details shall be as specified on Part 3 – Execution, if the Sections listed.

4. METHOD OF MEASUREMENT:

- 4.01 This item shall be measured for payment on a lump sum basis for the work completed in accordance with the Contract Documents and as directed by the Engineer.

5. BASIS OF PAYMENT:

- 5.01 Payment for this item shall be made at the lump sum bid price bid. The lump sum price bid shall include cost of furnishing all labor, material, equipment and appliances necessary to complete the work as indicated on the Contract Plans and as specified herein in the Sections listed.
- 5.02 Detailed Estimate:
 - A. Before the first certificate of payment is issued for the work under this item, submit a detailed estimate of quantities and prices for all materials, labor, and other items included under this item, which shall aggregate the contract lump sum price bid for this item. Prepare the detailed estimate in the same sequence as the Sections listed.
 - B. The detailed estimate shall be supported by such evidence, including certified copies of subcontracts, as the Engineer may require.
 - C. The detailed estimate must be approved by the Engineer who may revise it as, in his/her reasonable judgment, is necessary to make the various item conform to their true values. The value of each certificate of payment will be based on the approved detailed estimate.
- 5.03 Monthly payments will be made for this item in proportion to the total amount of work completed.

ITEM 627.0010 25**SPECIALTIES****1. SPECIFICATION SUMMARY**

- A. Section 101400 SIGNAGE
 - B. Section 102800 TOILET, BATH, AND LAUNDRY ACCESSORIES
 - C. Section 104413 FIRE POTECTION CABINETS
- 1.02 This item shall include, but not be limited to, the following:
- A. Miscellaneous signage throughout the building's addition
 - B. Toilet room accessories such as toilets, lockers, sinks, etc.
 - C. Fire protection cabinets

SECTION 101400 - SIGNAGE

PART 1 - GENERAL

1.1 SUMMARY

- A. This Section includes the following:
1. Panel signs.

1.2 DEFINITIONS

- A. ADA-ABA Accessibility Guidelines: U.S. Architectural & Transportation Barriers Compliance Board's "Americans with Disabilities Act (ADA) Accessibility Guidelines for Buildings and Facilities; Architectural Barriers Act (ABA) Accessibility Guidelines."

1.3 ACTION SUBMITTALS

- A. Product Data: For each type of product indicated.
- B. Shop Drawings: Show fabrication and installation details for signs.
1. Show sign mounting heights, locations of supplementary supports to be provided by others, and accessories.
 2. Provide message list, typestyles, graphic elements, including tactile characters and Braille, and layout for each sign.
- C. Samples for Initial Selection: Manufacturer's color charts consisting of actual units or sections of units showing the full range of colors available for the following:
1. Aluminum.
 2. Acrylic sheet.
 3. Polycarbonate sheet.
 4. Fiberglass sheet.
 5. Die-cut vinyl characters and graphic symbols. Include representative samples of available typestyles and graphic symbols.
- D. Sign Schedule: Provide as Submittal.

1.4 QUALITY ASSURANCE

- A. Regulatory Requirements: Comply with applicable provisions in ADA-ABA Accessibility Guidelines and ICC/ANSI A117.1.

1.5 COORDINATION

- A. Coordinate placement of anchorage devices with templates for installing signs.

1.6 WARRANTY

- A. Special Warranty: Manufacturer's standard form in which manufacturer agrees to repair or replace components of signs that fail in materials or workmanship within specified warranty period.
1. Failures include, but are not limited to, the following:

Weedsport Addition to Maintenance Section and Roof Replacement, MP 304.2

- a. Deterioration of metal and polymer finishes beyond normal weathering.
 - b. Deterioration of embedded graphic image colors and sign lamination.
2. Warranty Period: Five years from date of Substantial Completion.

PART 2 - PRODUCTS

2.1 MATERIALS

- A. Acrylic Sheet: ASTM D 4802, Category A-1 (cell-cast sheet), Type UVA (UV absorbing).
- B. Polycarbonate Sheet: Of thickness indicated, manufactured by extrusion process, coated on both surfaces with abrasion-resistant coating:
 1. Impact Resistance: 16 ft-lbf/in. per ASTM D 256, Method A.
 2. Tensile Strength: 9000 lbf/sq. in. per ASTM D 638.
 3. Flexural Modulus of Elasticity: 340,000 lbf/sq. in. per ASTM D 790.
 4. Heat Deflection: 265 deg F at 264 lbf/sq. in. per ASTM D 648.
 5. Abrasion Resistance: 1.5 percent maximum haze increase for 100 revolutions of a Taber abraser with a load of 500 g per ASTM D 1044.
- C. Applied Vinyl: Die-cut characters from vinyl film of nominal thickness of 3 mils with pressure-sensitive adhesive backing, suitable for exterior applications.

2.2 PANEL SIGNS

- A. Basis-of-Design Product: Subject to compliance with requirements, provide **TAKEFORM, INC.: FUSION 51 series** or a comparable product by one of the following:
 1. APCO Graphics, Inc.
 2. ASI-Modulex, Inc.
 3. Mohawk Sign Systems.
- B. Interior Panel Signs: Provide smooth sign panel surfaces constructed to remain flat under installed conditions within a tolerance of plus or minus 1/16 inch measured diagonally from corner to corner, complying with the following requirements:
 1. High-Pressure Decorative Laminate: 0.035 inch thick.
 2. The sign shall incorporate balanced construction with the core sandwiched between laminates to prevent warping. Laminate on the sign face only shall not be acceptable.
 3. Tactile lettering shall be precision machined, raised 1/32", matte PETG and subsurface colored for scratch resistance.
 4. Signs shall incorporate a metal accent bar. Bars shall be dyed, brushed anodized aluminum .125" thick.
 5. The signage system shall be capable of accepting paper or acetate inserts to allow changing and updating as required. Insert modules shall have a .080 thickness non-glare acrylic window and shall be inlaid flush to sign face for a smooth, seamless appearance.
 6. The signage system shall, with the exception of directories and overheads, be a maximum 8.5" width to accommodate inserts printed on standard width paper.
 7. Manufacturer shall provide a PC template containing layout, font, color, artwork and trim lines to allow owner to produce inserts on a laser or inkjet printer.
 8. The signage system shall include modules allowing for inserts, notice holders, occupancy sliders, marker, magnetic, and cork pin boards. All modules shall be flush to sign face for a smooth, seamless appearance.

Weedsport Addition to Maintenance Section and Roof Replacement, MP 304.2

9. The signage system shall utilize an acrylic sphere for Grade II Braille inserted directly into a mark and scratch resistant, high pressure laminate sign face. Braille dots are to be pressure fit in high tolerance milled holes. Braille dots shall be half hemispherical domed and protruding a minimum of .025" high.
 10. The laminates (front and back) shall be pressure laminated and precision machined together to a 90 degree angle. Edges shall be smooth, void of chips, burrs, sharp edges, marks and polished to a satin luster.
 11. The signage system shall incorporate a shim plate. The shim shall raise the sign off the wall allowing for cleaning and/or painting without removal.
 12. Mounting: Unframed.
 - a. Wall mounted with two-face tape.
 - b. Manufacturer's standard anchors for substrates encountered.
- C. Brackets: Fabricate brackets and fittings for bracket-mounted signs from extruded aluminum to suit panel sign construction and mounting conditions indicated.
- D. Tactile and Braille Sign: Manufacturer's standard process for producing text and symbols complying with ADA-ABA Accessibility Guidelines and with ICC/ANSI A117.1. Text shall be accompanied by Grade 2 Braille. Produce precisely formed characters with square-cut edges free from burrs and cut marks; Braille dots with domed or rounded shape.
1. Raised-Copy Thickness: Not less than 1/32 inch.
- E. Panel Sign Schedule:
1. Code required signage to be included in base bid.
 - a. Locations and Quantity – Refer to Floor Plan Drawing A201.
 - b. Signage dimensions, text size and type, and tactile and braille components are to comply with the ADA-ABA Accessibility Guidelines, ICC/ANSI A117.1, and the New York State Building Code.
 - c. Code required signage includes the following types:
 - 1) Sign Type 1: Accessible Toilet Room – Men
 - 2) Sign Type 2: Accessible Toilet Room - Women
 - 3) Sign Type 3: Accessible Toilet Room - Unisex
 - 4) Sign Type 4: Tactile Exit Sign
 - 5) Sign Type 5: Tactile Directional Exit Sign

2.3 TRUSS IDENTIFICATION SIGNAGE

- A. Provide Truss Identification Signage in accordance with Title 19, part 1264, section 505.3 – Appendix H of the New York State Code
1. Signs identifying the existence of truss construction shall contain the roman alphanumeric designation of the construction type of the building, in accordance with the provisions for the classification of types of construction set forth in section 602 of the Building Code of New York State (see 19 NYCRR Part 1221), and an alphabetic designation for the structural components that are of truss construction, as follows:
 - a. “F” shall mean floor framing, including girders and beams
 - b. “R” shall mean roof framing
 - c. “FR” shall mean floor and roof framing
 2. The construction type designation shall be placed at the twelve o'clock position over the structural component designation, which shall be placed at the six o'clock position.
 3. (f) Signs identifying the existence of truss construction shall be affixed in the locations specified in Table I-1264.

Weedsport Addition to Maintenance Section and Roof Replacement, MP 304.2

- B. Sign shall consist of a circle 6 inches in diameter, with a stroke width of ½ inch. The sign background shall be reflective white in color. The circle and contents shall be reflective red in color, conforming to Pantone matching system (PMS) #187.
 - 1. Where a sign is directly applied to a door or sidelight, it may be a permanent non-fading sticker or decal. Signs not directly applied to doors or sidelights shall be of sturdy, non-fading, weather resistant material.
- C. Signs to be provided at all exterior doors.

PART 3 - EXECUTION

3.1 EXAMINATION

- A. Examine substrates, areas, and conditions, with Installer present, for compliance with requirements for installation tolerances and other conditions affecting performance of work.
- B. Verify that items, including anchor inserts, are sized and located to accommodate signs.
- C. Proceed with installation only after unsatisfactory conditions have been corrected.

3.2 INSTALLATION

- A. Locate signs and accessories where indicated, using mounting methods of types described and complying with manufacturer's written instructions.
 - 1. Install signs level, plumb, and at heights indicated, with sign surfaces free of distortion and other defects in appearance.
 - 2. Interior Wall Signs: Install signs on walls adjacent to latch side of door where applicable. Where not indicated or possible, such as double doors, install signs on nearest adjacent walls. Locate to allow approach within 3 inches of sign without encountering protruding objects or standing within swing of door.
- B. Wall-Mounted Signs: Comply with sign manufacturer's written instructions except where more stringent requirements apply.
 - 1. Two-Face Tape: Mount signs to smooth, nonporous surfaces. Do not use this method for vinyl-covered or rough surfaces.
 - 2. Hook-and-Loop Tapes: Mount signs to smooth, nonporous surfaces.
 - 3. Magnetic Tape: Mount signs to smooth, nonporous surfaces.
 - 4. Silicone-Adhesive Mounting: Attach signs to irregular, porous, or vinyl-covered surfaces.
 - 5. Shim Plate Mounting: Provide 1/8-inch-thick, concealed aluminum shim plates with predrilled and countersunk holes, at locations indicated, and where other mounting methods are not practicable. Attach plate with fasteners and anchors suitable for secure attachment to substrate. Attach panel signs to plate using method specified above.
 - 6. Mechanical Fasteners: Use nonremovable mechanical fasteners placed through predrilled holes. Attach signs with fasteners and anchors suitable for secure attachment to substrate as recommended in writing by sign manufacturer.
 - 7. Signs Mounted on Glass: Provide matching opaque plate on opposite side of glass to conceal mounting materials.
- C. Bracket-Mounted Signs: Provide manufacturer's standard brackets, fittings, and hardware for mounting signs that project at right angles from walls and ceilings. Attach brackets and fittings

Weedsport Addition to Maintenance Section and Roof Replacement, MP 304.2

securely to walls and ceilings with concealed fasteners and anchoring devices to comply with manufacturer's written instructions.

3.3 CLEANING AND PROTECTION

- A. After installation, clean soiled sign surfaces according to manufacturer's written instructions. Protect signs from damage until acceptance by Owner.

END OF SECTION 101400

SECTION 102800 - TOILET, BATH, AND LAUNDRY ACCESSORIES

PART 1 - GENERAL

1.1 SUMMARY

- A. Section Includes:
 - 1. Public-use washroom accessories.
- B. Owner-Furnished Material: Refer to drawings

1.2 ACTION SUBMITTALS

- A. Product Data: For each type of product indicated. Include the following:
 - 1. Construction details and dimensions.
 - 2. Anchoring and mounting requirements, including requirements for cutouts in other work and substrate preparation.
 - 3. Material and finish descriptions.
 - 4. Features that will be included for Project.
 - 5. Manufacturer's warranty.
- B. Product Schedule: Indicating types, quantities, sizes, and installation locations by room of each accessory required.
 - 1. Identify locations using room designations indicated.
 - 2. Identify products using designations indicated.

1.3 INFORMATIONAL SUBMITTALS

- A. Warranty: Sample of special warranty.

1.4 CLOSEOUT SUBMITTALS

- A. Maintenance Data: For toilet and bath accessories to include in maintenance manuals.

1.5 QUALITY ASSURANCE

- A. Source Limitations: For products listed together in the same Part 2 articles, obtain products from single source from single manufacturer.
- B. Electrical Components, Devices, and Accessories: Listed and labeled as defined in NFPA 70, by a qualified testing agency, and marked for intended location and application.

1.6 COORDINATION

- A. Coordinate accessory locations with other work to prevent interference with clearances required for access by people with disabilities, and for proper installation, adjustment, operation, cleaning, and servicing of accessories.
- B. Deliver inserts and anchoring devices set into concrete or masonry as required to prevent delaying the Work.

Weedsport Addition to Maintenance Section and Roof Replacement, MP 304.2

1.7 WARRANTY

- A. Special Mirror Warranty: Manufacturer's standard form in which manufacturer agrees to replace mirrors that develop visible silver spoilage defects and that fail in materials or workmanship within specified warranty period.
1. Warranty Period: 15 years from date of Substantial Completion.

PART 2 - PRODUCTS**2.1 MATERIALS**

- A. Stainless Steel: ASTM A 666, Type 304, 0.031-inch minimum nominal thickness unless otherwise indicated.
- B. Brass: ASTM B 19, flat products; ASTM B 16/B 16M, rods, shapes, forgings, and flat products with finished edges; or ASTM B 30, castings.
- C. Steel Sheet: ASTM A 1008/A 1008M, Designation CS (cold rolled, commercial steel), 0.036-inch minimum nominal thickness.
- D. Galvanized-Steel Sheet: ASTM A 653/A 653M, with G60 hot-dip zinc coating.
- E. Galvanized-Steel Mounting Devices: ASTM A 153/A 153M, hot-dip galvanized after fabrication.
- F. Fasteners: Screws, bolts, and other devices of same material as accessory unit and tamper-and-theft resistant where exposed, and of galvanized steel where concealed.
- G. Chrome Plating: ASTM B 456, Service Condition Number SC 2 (moderate service).
- H. Mirrors: ASTM C 1503, Mirror Glazing Quality, clear-glass mirrors, nominal 6.0 mm thick.
- I. ABS Plastic: Acrylonitrile-butadiene-styrene resin formulation.

2.2 PUBLIC-USE WASHROOM ACCESSORIES

- A. Manufacturers: Subject to compliance with requirements, available manufacturers offering products that may be incorporated into the Work include, but are not limited to, the following:
1. A & J Washroom Accessories, Inc.
 2. American Specialties, Inc.
 3. Bobrick Washroom Equipment, Inc.
 4. Bradley Corporation.
- B. Grab Bar:
1. Basis-of-Design Product: Bobrick Washroom Equipment, Inc. – B-5806 series
 2. Mounting: Flanges with concealed fasteners.
 3. Material: Stainless steel, 0.05 inch thick.
 - a. Finish: Smooth, No. 4 finish (satin).
 4. Outside Diameter: 1-1/4 inches.
 5. Configuration and Length: As indicated on Drawings.
- C. Mirror Unit:
1. Basis-of-Design Product: Bobrick Washroom Equipment, Inc.
 - a. Model B-290 Series
 2. Frame: Stainless-steel angle.
 - a. Corners: Manufacturer's standard, welded.

Weedsport Addition to Maintenance Section and Roof Replacement, MP 304.2

3. Hangers: Produce rigid, tamper- and theft-resistant installation, using method indicated below.
 - a. One-piece, galvanized-steel, wall-hanger device with spring-action locking mechanism to hold mirror unit in position with no exposed screws or bolts.
 - b. Wall bracket of galvanized steel, equipped with concealed locking devices requiring a special tool to remove.
- D. Toilet Tissue (Roll) Dispenser:
1. Basis-of-Design Product: Bobrick B-2740.
 2. Description: Double-roll dispenser.
 3. Mounting: Surface mounted.
 4. Capacity: Designed for **up to 6"** diameter tissue rolls.
 5. Material and Finish: Cast aluminum (satin finish).
- E. Paper Towel Roll Dispenser:
1. Basis-of-Design Product: Bobrick No. B-253
 2. Mounting: Surface mounted.
 3. Minimum Capacity: 6" diameter standard paper towel roll.
 4. Material and Finish: Cast aluminum (satin finish).
- F. Liquid-Soap Dispenser:
1. Basis-of-Design Product: Bobrick No. B-26617
 2. Description: Designed for dispensing soap in liquid or lotion form.
 3. Mounting: Vertically oriented, surface mounted.
 4. Capacity: 1000 ml
 5. Materials: Stainless steel, Type 304.
 - a. Finish: Smooth, No. 4, satin finish.
 6. Lockset: Bobrick system key.
 7. Refill Indicator: Window type.
- G. Sanitary-Napkin Disposal Unit:
1. Basis-of-Design Product: Bobrick No. B-270.
 2. Mounting: Surface mounted,
 3. Receptacle: Removable.
 4. Material and Finish: Stainless steel, No. 4 finish (satin).
- H. Surface-Mounted QuietDry Series Hand Dryer:
1. Basis of Design: Bobrick TerraDry Model B-7188 115V.
 - a. Cover: One-piece, aluminum die-casting with chrome finish.
 - b. Power: 115V AC, 8.5 amp, 1000 watts, 50/60 Hz, single phase, cULus listed.

2.3 CUSTODIAL ACCESSORIES

- A. Manufacturers: Subject to compliance with requirements, provide products by one of the following:
1. American Specialties, Inc.
 2. Bobrick Washroom Equipment, Inc.
 3. Bradley Corporation.
- B. Mop and Broom Holder:
1. Description: Unit with shelf, hooks, holders, and rod suspended beneath shelf.

Weedsport Addition to Maintenance Section and Roof Replacement, MP 304.2

2. Length: 36 inches.
3. Mop/Broom Holders: Four, spring-loaded, rubber hat, cam type.
4. Material and Finish: Stainless steel, No. 4 finish (satin).
 - a. Shelf: Not less than nominal 0.05-inch- thick stainless steel.
 - b. Rod: Approximately 1/4-inch- diameter stainless steel.

2.4 CLOTHES HOOK

- A. Manufacturers: Subject to compliance with requirements, provide products by one of the following:
 1. American Specialties, Inc.
 2. Bobrick Washroom Equipment, Inc. B 211 (Basis of Design)
 3. Bradley Corporation.
- B. Locations: As indicated on the drawings.
 1. Description: Heavy duty clothes hook
 2. Material and Finish: Stainless steel, No. 4 finish (satin).

2.5 FABRICATION

- A. General: Fabricate units with tight seams and joints, and exposed edges rolled. Hang doors and access panels with full-length, continuous hinges. Equip units for concealed anchorage and with corrosion-resistant backing plates.

PART 3 - EXECUTION

3.1 INSTALLATION

- A. Install accessories according to manufacturers' written instructions, using fasteners appropriate to substrate indicated and recommended by unit manufacturer. Install units level, plumb, and firmly anchored in locations and at heights indicated.
- B. Grab Bars: Install to withstand a downward load of at least 250 lbf, when tested according to ASTM F 446.

3.2 ADJUSTING AND CLEANING

- A. Adjust accessories for unencumbered, smooth operation. Replace damaged or defective items.
- B. Remove temporary labels and protective coatings.
- C. Clean and polish exposed surfaces according to manufacturer's written recommendations.

END OF SECTION 102800

SECTION 104413 - FIRE PROTECTION CABINETS

PART 1 - GENERAL

1.1 SUMMARY

- A. Section Includes:
1. Fire-protection cabinets
 2. Portable fire extinguishers.

1.2 ACTION SUBMITTALS

- A. Product Data: For each type of product. Show door hardware, cabinet type, trim style, and panel style. Include roughing-in dimensions and details showing recessed-, semirecessed-, or surface-mounting method and relationships of box and trim to surrounding construction.
- B. Shop Drawings: For fire-protection cabinets. Include plans, elevations, sections, details, and attachments to other work.
- C. Product Schedule: For fire-protection cabinets. Indicate whether recessed, semirecessed, or surface mounted. Coordinate final fire-protection cabinet schedule with fire-extinguisher schedule to ensure proper fit and function.

1.3 CLOSEOUT SUBMITTALS

- A. Maintenance Data: For fire-protection cabinets to include in maintenance manuals.

1.4 COORDINATION

- A. Coordinate size of fire-protection cabinets to ensure that type and capacity of fire extinguishers indicated are accommodated.
- B. Coordinate sizes and locations of fire-protection cabinets with wall depths.

PART 2 - PRODUCTS

2.1 PERFORMANCE REQUIREMENTS

- A. Fire-Rated Fire-Protection Cabinets: Listed and labeled to comply with requirements in ASTM E 814 for fire-resistance rating of walls where they are installed.

2.2 FIRE-PROTECTION CABINET

- A. Cabinet Type: Suitable for fire extinguisher.
1. Products: Subject to compliance with requirements, provide one of the following:
 - a. Larsens Manufacturing Company. **Architectural Series, Vertical Duo Door Model 2409-6R – (Basis of Design)**

Weedsport Addition to Maintenance Section and Roof Replacement, MP 304.2

- b. Potter Roemer LLC.
 - c. JL Industries, Inc.; a division of the Activar Construction Products Group.
- B. Cabinet Construction: Nonrated, 1-hour fire rated, or 2-hour fire rated as required by wall construction.
- 1. Fire-Rated Cabinets: Construct fire-rated cabinets with double walls fabricated from 0.043-inch-thick cold-rolled steel sheet lined with minimum 5/8-inch-thick fire-barrier material. Provide factory-drilled mounting holes.
- C. Cabinet Material: Cold-rolled steel sheet.
- D. Semirecessed Cabinet: One-piece combination trim and perimeter door frame overlapping surrounding wall surface with exposed trim face and wall return at outer edge (backbend).
- 1. Rolled-Edge Trim: 2-1/2-inch backbend depth.
- E. Cabinet Trim Material: Steel sheet.
- F. Door Material: Steel sheet.
- G. Door Hardware: Manufacturer's standard door-operating hardware of proper type for cabinet type, trim style, and door material and style indicated.
- 1. Provide projecting lever handle with cam-action latch.
 - 2. Provide manufacturer's standard hinge permitting door to open 180 degrees.
- H. Accessories:
- 1. Identification for fire extinguisher cabinet: Lettering complying with authorities having jurisdiction for letter style, size, spacing, and location. Locate as directed by Architect.
 - a. Identify fire extinguisher in fire-protection cabinet with the words "FIRE EXTINGUISHER."
 - 1) Location: Applied to cabinet door.
 - 2) Application Process: Silk-screened.
 - 3) Lettering Color: Red.
 - 4) Orientation: Horizontal.
 - 2. Identification: Fire extinguisher location sign: Wall mounted 3-way view sign.
 - a. Identify fire extinguisher in fire-protection cabinet with the ARROW pointing down and words "FIRE EXTINGUISHER."
 - 1) Location: Wall mounted above fire extinguisher cabinet
 - 2) Plastic tent sign, 18" long; BAasis-of-Design: JL Industries 23S.
 - 3) Colors: White background, Red arrow, White lettering.

Weedsport Addition to Maintenance Section and Roof Replacement, MP 304.2

4) Orientation: Vertical.

I. Cabinet Materials:

1. Cold-Rolled Steel: ASTM A 1008/A 1008M, Commercial Steel (CS), Type B.
 - a. Finish: Baked enamel or powder coat.
 - b. Color: As selected by Architect from full range of industry colors and color densities.

2.3 PORTABLE FIRE EXTINGUISHERS

- A. General: Provide fire extinguishers, of type, size, and capacity indicated, for each cabinet.
- B. Multipurpose Dry-Chemical Type: UL-rated 4-A : 80-B : C, 10-lb (4.5-kg) nominal capacity, in enameled-steel container.
- C. Provide one additional extinguisher of the same type, with a bracket for wall mounting, in the Mechanical Room.

2.4 FABRICATION

- A. Fire-Protection Cabinets: Provide manufacturer's standard box (tub) with trim, frame, door, and hardware to suit cabinet type, trim style, and door style indicated.
 1. Weld joints and grind smooth.
 2. Provide factory-drilled mounting holes.
 3. Prepare doors and frames to receive locks.
 4. Install door locks at factory.
- B. Cabinet Doors: Fabricate doors according to manufacturer's standards, from materials indicated and coordinated with cabinet types and trim styles.
 1. Fabricate door frames with tubular stiles and rails and hollow-metal design, minimum 1/2 inch thick.
 2. Fabricate door frames of one-piece construction with edges flanged.
 3. Miter and weld perimeter door frames.
- C. Cabinet Trim: Fabricate cabinet trim in one piece with corners mitered, welded, and ground smooth.

2.5 GENERAL FINISH REQUIREMENTS

- A. Comply with NAAMM's AMP 500, "Metal Finishes Manual for Architectural and Metal Products," for recommendations for applying and designating finishes.

Weedsport Addition to Maintenance Section and Roof Replacement, MP 304.2

- B. Protect mechanical finishes on exposed surfaces of fire-protection cabinets from damage by applying a strippable, temporary protective covering before shipping.
- C. Finish fire-protection cabinets after assembly.
- D. Appearance of Finished Work: Noticeable variations in same piece are not acceptable. Variations in appearance of adjoining components are acceptable if they are within the range of approved Samples and are assembled or installed to minimize contrast.

PART 3 - EXECUTION**3.1 EXAMINATION**

- A. Examine walls and partitions for suitable framing depth and blocking where semirecessed cabinets will be installed.
- B. Proceed with installation only after unsatisfactory conditions have been corrected.

3.2 PREPARATION

- A. Prepare recesses for semirecessed fire-protection cabinets as required by type and size of cabinet and trim style.

3.3 INSTALLATION

- A. General: Install fire-protection cabinets in locations and at mounting heights indicated or, if not indicated, at heights acceptable to authorities having jurisdiction.
- B. Fire-Protection Cabinets: Fasten cabinets to structure, square and plumb.
 - 1. Unless otherwise indicated, provide recessed fire-protection cabinets. If wall thickness is inadequate for recessed cabinets, provide semirecessed fire-protection cabinets.
 - 2. Provide inside latch and lock for break-glass panels.
 - 3. Fasten mounting brackets to inside surface of fire-protection cabinets, square and plumb.
- C. Identification: Apply decals at locations indicated.

3.4 ADJUSTING AND CLEANING

- A. Remove temporary protective coverings and strippable films, if any, as fire-protection cabinets are installed unless otherwise indicated in manufacturer's written installation instructions.
- B. Adjust fire-protection cabinet doors to operate easily without binding. Verify that integral locking devices operate properly.
- C. On completion of fire-protection cabinet installation, clean interior and exterior surfaces as recommended by manufacturer.

Weedsport Addition to Maintenance Section and Roof Replacement, MP 304.2

- D. Touch up marred finishes, or replace fire-protection cabinets that cannot be restored to factory-finished appearance. Use only materials and procedures recommended or furnished by fire-protection cabinet and mounting bracket manufacturers.
- E. Replace fire-protection cabinets that have been damaged or have deteriorated beyond successful repair by finish touchup or similar minor repair procedures.

END OF SECTION 104413

ITEM 627.0012 25**FURNISHINGS****1. DESCRIPTION:**

- 1.01 Furnish all labor, materials, equipment and services necessary to complete the work as indicated on the Contract Plans and the attached Specification Summary.
- 1.02 All work shall conform to the requirements specified in Part 1 – General, of the Sections listed.

2. MATERIALS:

- 2.01 The materials shall be as specified in Part 2 – Products, of the Sections listed.

3. CONSTRUCTION DETAILS:

- 3.01 The construction details shall be as specified on Part 3 – Execution, if the Sections listed.

4. METHOD OF MEASUREMENT:

- 4.01 This item shall be measured for payment on a lump sum basis for the work completed in accordance with the Contract Documents and as directed by the Engineer.

5. BASIS OF PAYMENT:

- 5.01 Payment for this item shall be made at the lump sum bid price bid. The lump sum price bid shall include cost of furnishing all labor, material, equipment and appliances necessary to complete the work as indicated on the Contract Plans and as specified herein in the Sections listed.
- 5.02 Detailed Estimate:
 - A. Before the first certificate of payment is issued for the work under this item, submit a detailed estimate of quantities and prices for all materials, labor, and other items included under this item, which shall aggregate the contract lump sum price bid for this item. Prepare the detailed estimate in the same sequence as the Sections listed.
 - B. The detailed estimate shall be supported by such evidence, including certified copies of subcontracts, as the Engineer may require.
 - C. The detailed estimate must be approved by the Engineer who may revise it as, in his/her reasonable judgment, is necessary to make the various item conform to their true values. The value of each certificate of payment will be based on the approved detailed estimate.
- 5.03 Monthly payments will be made for this item in proportion to the total amount of work completed.

ITEM 627.0012 25**FURNISHINGS****1. SPECIFICATION SUMMARY**

1.01 This Item includes the following specifications:

- A. Section 123530 RESIDENTIAL CASEWORK
- B. Section 123661 SOLID SURFACING COUNTERTOPS

1.02 This item shall include, but not be limited to, the following:

- A. Casework and countertops for the building's addition

SECTION 123530 - RESIDENTIAL CASEWORK

PART 1 - GENERAL

1.1 SUMMARY

- A. Section includes kitchen cabinets.

1.2 ACTION SUBMITTALS

- A. Product Data: For each type of product.
- B. Shop Drawings: For residential casework. Include plans, elevations, details, and attachments to other work.
- C. Samples: For casework and hardware finishes.

1.3 INFORMATIONAL SUBMITTALS

- A. Product Certificates: For casework.

PART 2 - PRODUCTS

2.1 CABINETS

- A. Basis of Design: Masco Cabinetry - KRAFTMAID.
- B. Quality Standard: Provide cabinets that comply with KCMA A161.1.
 - 1. KCMA Certification: Provide cabinets with KCMA's "Certified Cabinet" seal affixed in a semiexposed location of each unit and showing compliance with KCMA A161.1.
- C. Door and Drawer Face Style: Reveal overlay.
 - 1. Door and Drawer Fronts: Solid-wood stiles and rails, 3/4 inch (19 mm) thick, with 1/4-inch- (6.4-mm-) thick, veneer-faced plywood center panels.
- D. Cabinet Style: Face frame.
 - 1. Face Frames: 3/4-by-1-5/8-inch (19-by-41-mm) solid wood.
- E. Exposed Cabinet End Finish: Wood veneer.

2.2 CABINET MATERIALS

- A. Hardwood Lumber: Kiln dried to 7 percent moisture content.
- B. Softwood Lumber: Kiln dried to 10 percent moisture content.
- C. Hardwood Plywood: HPVA HP-1.
- D. Particleboard: ANSI A208.1, Grade M-2.
- E. Particleboard: Straw-based particleboard complying with requirements in ANSI A208.1, Grade M-2, except for density.
- F. MDF: Medium-density fiberboard, ANSI A208.2, Grade MD.
- G. Hardboard: ANSI A135.4, Class 1 tempered.

Weedsport Addition to Maintenance Section and Roof Replacement, MP 304.2

H. Exposed Materials:

1. Exposed Wood Species: Oak.
 - a. Select materials for compatible color and grain. Do not use two adjacent exposed surfaces that are noticeably dissimilar in color, grain, figure, or natural character markings.
 - b. Staining and Finish: As selected by Architect from manufacturer's full range.
2. Solid Wood: Clear hardwood lumber of species indicated, free of defects.
3. Plywood: Hardwood plywood with face veneer of species indicated, with Grade A faces and Grade C backs of same species as faces.
 - a. Edge band exposed edges with veneer edging of same species as face veneer.
4. Plastic Laminate: Particleboard faced with high-pressure decorative laminate complying with NEMA LD 3, Grade VGS and edgebanded.
 - a. Colors, Textures, and Patterns: As selected by Architect from cabinet manufacturer's full range.
 - b. Plastic-Laminate Edgebanding: Of same grade, pattern, color, and texture of plastic laminate as for faces.
 - c. PVC Edgebanding: Rigid PVC extrusions, through color with satin finish, 3 mm thick at doors and drawer fronts, and 1 mm thick elsewhere.
 - 1) Color: As selected by Architect from cabinet manufacturer's full range.

I. Semiexposed Materials: Unless otherwise indicated, provide the following:

1. Solid Wood: Sound hardwood lumber, selected to eliminate appearance defects. Same species as exposed surfaces.
2. Plywood: Hardwood plywood with Grade C faces and not less than Grade 3 backs of same species as faces. Face veneers of same species as exposed surfaces.
3. Plastic Laminate: Particleboard faced with high-pressure decorative laminate complying with NEMA LD 3, Grade VGS.

J. Concealed Materials: Solid wood or plywood, of any hardwood or softwood species, with no defects affecting strength or utility; particleboard; MDF; or hardboard.

2.3 CABINET HARDWARE

- A. General: Manufacturer's standard units complying with BHMA A156.9, of type, size, style, material, and finish as selected by Architect from manufacturer's full range.
- B. Pulls: Back-mounted decorative pulls.
- C. Hinges: Concealed European-style, self-closing hinges.
- D. Drawer Guides: Epoxy-coated-metal, self-closing drawer guides; designed to prevent rebound when drawers are closed; with nylon-tired, ball-bearing rollers; and complying with BHMA A156.9, Type B05011 or Type B05091.
- E. Door and Drawer Bumpers: Self-adhering, clear silicone rubber.

Weedsport Addition to Maintenance Section and Roof Replacement, MP 304.2

1. Doors: Provide one bumper at top and bottom of closing edge of each swinging door.
2. Drawers: Provide one bumper on back side of drawer front at each corner.

PART 3 - EXECUTION

3.1 INSTALLATION

- A. Install casework with no variations in adjoining surfaces; use concealed shims. Where casework abuts other finished work, scribe and cut for accurate fit. Provide filler strips, scribe strips, and moldings in finish to match casework.
- B. Install casework without distortion so doors and drawers fit the openings, are aligned, and are uniformly spaced. Complete installation of hardware and accessories as indicated.
- C. Install casework level and plumb to a tolerance of 1/8 inch in 8 feet (3 mm in 2.4 m).
- D. Fasten casework to adjacent units and to backing.
 1. Fasten wall cabinets through back, near top and bottom, and at ends not more than 16 inches (400 mm) o.c.
 - a. Fasteners: No. 10 wafer-head screws sized for not less than 1-1/2-inch (38-mm) penetration into wood framing, blocking, or hanging strips or No. 10 wafer-head sheet metal screws through the metal backing or metal framing behind the wall finish.
- E. Adjust hardware so doors and drawers are centered in openings and operate smoothly without warp or bind. Lubricate operating hardware as recommended by manufacturer.
- F. Clean casework on exposed and semiexposed surfaces. Touch up as required to restore damaged or soiled areas to match original factory finish, as approved by Architect.

END OF SECTION 123530

SECTION 123661.16 - SOLID SURFACING COUNTERTOPS

PART 1 - GENERAL

1.1 SUMMARY

A. Section Includes:

1. Solid surface material countertops.
2. Solid surface material backsplashes.
3. Solid surface material end splashes.
4. Solid surface material window sills
5. Solid surface material sinks.

1.2 ACTION SUBMITTALS

A. Product Data: For countertop materials.

B. Shop Drawings: For countertops. Show materials, finishes, edge and backsplash profiles, methods of joining, and cutouts for plumbing fixtures.

1. Show locations and details of joints.
2. Show direction of directional pattern, if any.

C. Samples for Initial Selection: For each type of material exposed to view.

1.3 INFORMATIONAL SUBMITTALS

A. Qualification Data: For fabricator.

1.4 CLOSEOUT SUBMITTALS

A. Maintenance Data: For solid surface material countertops to include in maintenance manuals. Include Product Data for care products used or recommended by Installer and names, addresses, and telephone numbers of local sources for products.

1.5 QUALITY ASSURANCE

A. Fabricator Qualifications: Shop that employs skilled workers who custom-fabricate countertops similar to that required for this Project, and whose products have a record of successful in-service performance.

B. Installer Qualifications: Fabricator of countertops.

1.6 FIELD CONDITIONS

A. Field Measurements: Verify dimensions of countertops by field measurements before countertop fabrication is complete.

1.7 COORDINATION

A. Coordinate locations of utilities that will penetrate countertops or backsplashes.

PART 2 - PRODUCTS

2.1 SOLID SURFACE COUNTERTOP MATERIALS

- A. Solid Surface Material: Homogeneous-filled plastic resin complying with ICPA SS-1.
1. Basis-of-Design Product: Subject to compliance with requirements, provide E. I. du Pont de Nemours and Company; Corian.
 2. Type: Provide Standard type unless Special Purpose type is indicated.
 3. Integral Sink Bowls: Comply with CSA B45.5/IAPMO Z124.
 4. Colors and Patterns: As selected by Architect.
- B. Plywood: Exterior softwood plywood complying with DOC PS 1, Grade C-C Plugged, touch sanded.

2.2 COUNTERTOP FABRICATION

- A. Fabricate countertops according to solid surface material manufacturer's written instructions and to the AWI/AWMAC/WI's "Architectural Woodwork Standards."
1. Grade: Premium.
- B. Configuration:
1. Front: Straight, slightly eased at top.
 2. Backsplash: Straight, slightly eased at corner.
 3. End Splash: Matching backsplash.
- C. Countertops: 1/2-inch- (12.7-mm-) thick, solid surface material with front edge built up with same material.
- D. Backsplashes: 1/2-inch- (12.7-mm-) thick, solid surface material.
- E. Fabricate tops with shop-applied edges unless otherwise indicated. Comply with solid surface material manufacturer's written instructions for adhesives, sealers, fabrication, and finishing.
1. Fabricate with loose backsplashes for field assembly.
 2. Install integral sink bowls in countertops in the shop.
- F. Joints: Fabricate countertops without joints.
- G. Cutouts and Holes:
1. Undercounter Plumbing Fixtures: Make cutouts for fixtures in shop using template or pattern furnished by fixture manufacturer. Form cutouts to smooth, even curves.
 - a. Provide vertical edges, rounded to 3/8-inch (10-mm) radius at juncture of cutout edges with top surface of countertop, slightly eased at bottom, and projecting 3/16 inch (5 mm) into fixture opening.
 2. Counter-Mounted Plumbing Fixtures: Prepare countertops in shop for field cutting openings for counter-mounted fixtures. Mark tops for cutouts and drill holes at corners of cutout locations. Make corner holes of largest radius practical.
 3. Fittings: Drill countertops in shop for plumbing fittings, undercounter soap dispensers, and similar items.

2.3 INSTALLATION MATERIALS

- A. Adhesive: Product recommended by solid surface material manufacturer.
- B. Sealant for Countertops: Comply with applicable requirements in Section 079200 "Joint Sealants."

PART 3 - EXECUTION**3.1 EXAMINATION**

- A. Examine substrates to receive solid surface material countertops and conditions under which countertops will be installed, with Installer present, for compliance with requirements for installation tolerances and other conditions affecting performance of countertops.
- B. Proceed with installation only after unsatisfactory conditions have been corrected.

3.2 INSTALLATION

- A. Install countertops level to a tolerance of 1/8 inch in 8 feet (3 mm in 2.4 m), 1/4 inch (6 mm) maximum. Do not exceed 1/64-inch (0.4-mm) difference between planes of adjacent units.
- B. Secure countertops to cabinets with adhesive according to solid surface material manufacturer's written instructions. Align adjacent surfaces and, using adhesive in color to match countertop, form seams to comply with manufacturer's written instructions. Carefully dress joints smooth, remove surface scratches, and clean entire surface.
- C. Install backsplashes and end splashes by adhering to wall and countertops with adhesive. Mask areas of countertops and splashes adjacent to joints to prevent adhesive smears.
- D. Complete cutouts not finished in shop. Mask areas of countertops adjacent to cutouts to prevent damage while cutting. Make cutouts to accurately fit items to be installed, and at right angles to finished surfaces unless beveling is required for clearance. Ease edges slightly to prevent snipping.
- E. Seal edges of cutouts in particleboard subtops by saturating with varnish.
- F. Apply sealant to gaps at walls; comply with Section 079200 "Joint Sealants."

END OF SECTION 123661.16

ITEM 627.0022 25**PLUMBING****1. DESCRIPTION:**

- 1.01 Furnish all labor, materials, equipment and services necessary to complete the work as indicated on the Contract Plans and the Specification Sections listed below
- 1.04 All work shall conform to the requirements specified in Part 1 – General, of the Sections listed.

2. MATERIALS:

- 2.01 The materials shall be as specified in Part 2 – Products, of the Sections listed.

3. CONSTRUCTION DETAILS:

- 3.01 The construction details shall be as specified on Part 3 – Execution, if the Sections listed.

4. METHOD OF MEASUREMENT:

- 4.01 This item shall be measured for payment on a lump sum basis for the work completed in accordance with the Contract Documents and as directed by the Engineer.

5. BASIS OF PAYMENT:

- 5.01 Payment for this item shall be made at the lump sum bid price bid. The lump sum price bid shall include cost of furnishing all labor, material, equipment and appliances necessary to complete the work as indicated on the Contract Plans and as specified herein in the Sections listed.
- 5.02 Detailed Estimate:
 - A. Before the first certificate of payment is issued for the work under this item, submit a detailed estimate of quantities and prices for all materials, labor, and other items included under this item, which shall aggregate the contract lump sum price bid for this item. Prepare the detailed estimate in the same sequence as the Sections listed.
 - B. The detailed estimate shall be supported by such evidence, including certified copies of subcontracts, as the Engineer may require.
 - C. The detailed estimate must be approved by the Engineer who may revise it as, in his/her reasonable judgment, is necessary to make the various item conform to their true values. The value of each certificate of payment will be based on the approved detailed estimate.
- 5.03 Monthly payments will be made for this item in proportion to the total amount of work completed.

1. SPECIFICATION SUMMARY

- 1.01 This Item includes the following specifications:
 - A. Section 220517 SLEEVES AND SLEEVE SEALS FOR PLUMBING PIPING

ITEM 627.0022 25**PLUMBING**

- | | | |
|----|----------------|--|
| B. | Section 220518 | ESCUTCHEONS FOR PLUMBING PIPING |
| C. | Section 220519 | METERS AND GAUGES FOR PLUMBING PIPING |
| D. | Section 220523 | GENERAL DUTY VALYES FOR PLUMBING PIPING |
| E. | Section 220529 | HANGERS AND SUPPORTS FOR PLUMBING PIPING AND EQUIPMENT |
| F. | Section 220719 | PLUMBING PIPING INSULATION |
| G. | Section 221116 | DOMESTIC WATER PIPING |
| H. | Section 221119 | DOMESTIC WATER PIPING SPECIALTIES |
| I. | Section 221123 | DOMESTIC WATER PUMPS |
| J. | Section 221124 | NATURAL GAS PIPING |
| K. | Section 221316 | SANITARY WASTE AND VENT PIPING |
| L. | Section 221319 | SANITARY WASTE PIPING SPECIALTIES |
| M. | Section 221413 | FACILITY STORM DRAINAGE PIPING |
| N. | Section 221423 | STORM DRAINAGE PIPING SPECIALTIES |
| O. | Section 223400 | FUEL-FIRED DOMESTIC WATER HEATERS |
| P. | Section 224213 | COMMERCIAL WATER CLOSETS AND URINALS |
| Q. | Section 224216 | COMMERCIAL WATER SINKS AND LAVATORIES |
| R. | Section 224223 | COMMERCIAL SHOWERS |
| S. | Section 224716 | PRESSURE WATER COOLERS |

1.02 This item shall include, but not be limited to, the following:

- | | |
|----|--|
| A. | Plumbing necessary for the building's addition, including break room and locker room areas |
| B. | Storm water piping |
| C. | Piping needed to supply natural gas |

SECTION 220517 - SLEEVES AND SLEEVE SEALS FOR PLUMBING PIPING

PART 1 - GENERAL

1.1 RELATED DOCUMENTS

- A. Drawings and general provisions of the Contract, including General and Supplementary Conditions and Division 01 Specification Sections, apply to this Section.

1.2 SUMMARY

- A. Section Includes:
1. Sleeves.
 2. Stack-sleeve fittings.
 3. Sleeve-seal systems.
 4. Sleeve-seal fittings.
 5. Grout.

1.3 ACTION SUBMITTALS

- A. Product Data: For each type of product indicated.

PART 2 - PRODUCTS

2.1 SLEEVES

- A. Cast-Iron Wall Pipes: Cast or fabricated of cast or ductile iron and equivalent to ductile-iron pressure pipe, with plain ends and integral waterstop unless otherwise indicated.
- B. Galvanized-Steel Wall Pipes: ASTM A 53/A 53M, Schedule 40, with plain ends and welded steel collar; zinc coated.
- C. Galvanized-Steel-Pipe Sleeves: ASTM A 53/A 53M, Type E, Grade B, Schedule 40, zinc coated, with plain ends.
- D. PVC-Pipe Sleeves: ASTM D 1785, Schedule 40.

2.2 STACK-SLEEVE FITTINGS

- A. Manufacturers: Subject to compliance with requirements, available manufacturers offering products that may be incorporated into the Work include, but are not limited to, the following:
1. Smith, Jay R. Mfg. Co.
 2. Zurn Specification Drainage Operation; Zurn Plumbing Products Group.
- B. Description: Manufactured, cast-iron sleeve with integral clamping flange. Include clamping ring, bolts, and nuts for membrane flashing.
1. Underdeck Clamp: Clamping ring with setscrews.

2.3 SLEEVE-SEAL FITTINGS

- A. Manufacturers: Subject to compliance with requirements, available manufacturers offering products that may be incorporated into the Work include, but are not limited to, the following:
1. Presealed Systems.

Weedsport Addition to Maintenance Section and Roof Replacement, MP 304.2

- B. Description: Manufactured plastic, sleeve-type, waterstop assembly made for imbedding in concrete slab or wall. Unit has plastic or rubber waterstop collar with center opening to match piping OD.

2.4 GROUT

- A. Standard: ASTM C 1107/C 1107M, Grade B, post-hardening and volume-adjusting, dry, hydraulic-cement grout.
- B. Characteristics: Nonshrink; recommended for interior and exterior applications.
- C. Design Mix: 5000-psi, 28-day compressive strength.
- D. Packaging: Premixed and factory packaged.

PART 3 - EXECUTION

3.1 SLEEVE INSTALLATION

- A. Install sleeves for piping passing through penetrations in floors, partitions, roofs, and walls.
- B. For sleeves that will have sleeve-seal system installed, select sleeves of size large enough to provide 1-inch annular clear space between piping and concrete slabs and walls.
1. Sleeves are not required for core-drilled holes.
- C. Install sleeves in concrete floors, concrete roof slabs, and concrete walls as new slabs and walls are constructed.
1. Permanent sleeves are not required for holes in slabs formed by molded-PE or -PP sleeves.
 2. Cut sleeves to length for mounting flush with both surfaces.
 - a. Exception: Extend sleeves installed in floors of mechanical equipment areas or other wet areas 2 inches above finished floor level.
 3. Using grout, seal the space outside of sleeves in slabs and walls without sleeve-seal system.
- D. Install sleeves for pipes passing through interior partitions.
1. Cut sleeves to length for mounting flush with both surfaces.
 2. Install sleeves that are large enough to provide 1/4-inch annular clear space between sleeve and pipe or pipe insulation.
 3. Seal annular space between sleeve and piping or piping insulation; use joint sealants appropriate for size, depth, and location of joint. Comply with requirements for sealants specified in Section 079200 "Joint Sealants."

3.2 STACK-SLEEVE-FITTING INSTALLATION

- A. Install stack-sleeve fittings in new slabs as slabs are constructed.
1. Install fittings that are large enough to provide 1/4-inch annular clear space between sleeve and pipe or pipe insulation.
 2. Secure flashing between clamping flanges for pipes penetrating floors with membrane waterproofing. Comply with requirements for flashing specified in Section 076200 "Sheet Metal Flashing and Trim."
 3. Install section of cast-iron soil pipe to extend sleeve to 2 inches above finished floor level.
 4. Extend cast-iron sleeve fittings below floor slab as required to secure clamping ring if ring is specified.

Weedsport Addition to Maintenance Section and Roof Replacement, MP 304.2

5. Using grout, seal the space around outside of stack-sleeve fittings.

3.3 SLEEVE-SEAL-FITTING INSTALLATION

- A. Install sleeve-seal fittings in new walls and slabs as they are constructed.
- B. Assemble fitting components of length to be flush with both surfaces of concrete slabs and walls. Position waterstop flange to be centered in concrete slab or wall.
- C. Secure nailing flanges to concrete forms.
- D. Using grout, seal the space around outside of sleeve-seal fittings.

3.4 SLEEVE AND SLEEVE-SEAL SCHEDULE

- A. Use sleeves and sleeve seals for the following piping-penetration applications:
 1. Exterior Concrete Walls above Grade:
 - a. Piping Smaller Than NPS 6: Galvanized-steel-pipe sleeves.
 2. Exterior Concrete Walls below Grade:
 - a. Piping Smaller Than NPS 6: Sleeve-seal fittings.
 - 1) Select sleeve size to allow for 1-inch annular clear space between piping and sleeve for installing sleeve-seal system.
 - b. Piping NPS 6 and Larger: Galvanized-steel-pipe sleeves with sleeve-seal system.
 - 1) Select sleeve size to allow for 1-inch annular clear space between piping and sleeve for installing sleeve-seal system.
 3. Concrete Slabs-on-Grade:
 - a. Piping Smaller Than NPS 6: Sleeve-seal fittings.
 - 1) Select sleeve size to allow for 1-inch annular clear space between piping and sleeve for installing sleeve-seal system.
 - b. Piping NPS 6 and Larger: Galvanized-steel-pipe sleeves.
 - 1) Select sleeve size to allow for 1-inch annular clear space between piping and sleeve for installing sleeve-seal system.
 4. Concrete Slabs above Grade:
 - a. Piping Smaller Than NPS 6: Galvanized-steel-pipe sleeves or PVC-pipe sleeves.
 - b. Piping NPS 6 and Larger: Galvanized-steel-pipe sleeves or PVC-pipe sleeves.
 5. Interior Partitions:
 - a. Piping Smaller Than NPS 6: Galvanized-steel-pipe sleeves or PVC-pipe sleeves.
 - b. Piping NPS 6 and Larger: Galvanized-steel-sheet sleeves.

END OF SECTION 220517

SECTION 220518 - ESCUTCHEONS FOR PLUMBING PIPING

PART 1 - GENERAL

1.1 RELATED DOCUMENTS

- A. Drawings and general provisions of the Contract, including General and Supplementary Conditions and Division 01 Specification Sections, apply to this Section.

1.2 SUMMARY

- A. Section Includes:
 - 1. Escutcheons.
 - 2. Floor plates.

1.3 ACTION SUBMITTALS

- A. Product Data: For each type of product indicated.

PART 2 - PRODUCTS

2.1 ESCUTCHEONS

- A. One-Piece, Cast-Brass Type: With polished, chrome-plated finish and setscrew fastener.
- B. One-Piece, Deep-Pattern Type: Deep-drawn, box-shaped brass with chrome-plated finish and spring-clip fasteners.
- C. One-Piece, Stamped-Steel Type: With chrome-plated finish and spring-clip fasteners.
- D. Split-Casting Brass Type: With polished, chrome-plated finish and with concealed hinge and setscrew.

2.2 FLOOR PLATES

- A. One-Piece Floor Plates: Cast-iron flange with holes for fasteners.
- B. Split-Casting Floor Plates: Cast brass with concealed hinge.

PART 3 - EXECUTION

3.1 INSTALLATION

- A. Install escutcheons for piping penetrations of walls, ceilings, and finished floors.
- B. Install escutcheons with ID to closely fit around pipe, tube, and insulation of insulated piping and with OD that completely covers opening.
 - 1. Escutcheons for New Piping:
 - a. Piping with Fitting or Sleeve Protruding from Wall: One-piece, deep-pattern type.
 - b. Chrome-Plated Piping: One-piece, cast-brass type with polished, chrome-plated finish.
 - c. Insulated Piping: One-piece, stamped-steel type.
 - d. Bare Piping at Wall and Floor Penetrations in Finished Spaces: One-piece, cast-brass type with polished, chrome-plated finish.

Weedsport Addition to Maintenance Section and Roof Replacement, MP 304.2

- e. Bare Piping at Ceiling Penetrations in Finished Spaces: One-piece, cast-brass type with polished, chrome-plated finish.
 - f. Bare Piping in Unfinished Service Spaces: One-piece, cast-brass type with polished, chrome-plated finish.
 - g. Bare Piping in Equipment Rooms: One-piece, cast-brass type with polished, chrome-plated finish.
2. Escutcheons for Existing Piping:
- a. Chrome-Plated Piping: Split-casting brass type with polished, chrome-plated finish.
 - b. Insulated Piping: Split-plate, stamped-steel type with concealed or exposed-rivet hinge.
 - c. Bare Piping at Wall and Floor Penetrations in Finished Spaces: Split-casting brass type with polished, chrome-plated finish.
 - d. Bare Piping at Ceiling Penetrations in Finished Spaces: Split-casting brass type with polished, chrome-plated finish.
 - e. Bare Piping in Unfinished Service Spaces: Split-casting brass type with polished, chrome-plated finish.
 - f. Bare Piping in Equipment Rooms: Split-casting brass type with polished, chrome-plated finish.
- C. Install floor plates for piping penetrations of equipment-room floors.
- D. Install floor plates with ID to closely fit around pipe, tube, and insulation of piping and with OD that completely covers opening.
- 1. New Piping: One-piece, floor-plate type.
 - 2. Existing Piping: Split-casting, floor-plate type.

3.2 FIELD QUALITY CONTROL

- A. Replace broken and damaged escutcheons and floor plates using new materials.

END OF SECTION 220518

SECTION 220519 - METERS AND GAGES FOR PLUMBING PIPING

PART 1 - GENERAL

1.1 RELATED DOCUMENTS

- A. Drawings and general provisions of the Contract, including General and Supplementary Conditions and Division 01 Specification Sections, apply to this Section.

1.2 SUMMARY

- A. Section Includes:
1. Liquid-in-glass thermometers.
 2. Thermowells.
 3. Dial-type pressure gages.
 4. Gage attachments.
 5. Test plugs.
- B. Related Sections:
1. Section 221116 "Domestic Water Piping" for water meters inside the building.

1.3 ACTION SUBMITTALS

- A. Product Data: For each type of product indicated.

1.4 INFORMATIONAL SUBMITTALS

- A. Product Certificates: For each type of meter and gage, from manufacturer.

1.5 CLOSEOUT SUBMITTALS

- A. Operation and Maintenance Data: For meters and gages to include in operation and maintenance manuals.

PART 2 - PRODUCTS

2.1 LIQUID-IN-GLASS THERMOMETERS

- A. Metal-Case, Industrial-Style, Liquid-in-Glass Thermometers:
1. Manufacturers: Subject to compliance with requirements, available manufacturers offering products that may be incorporated into the Work include, but are not limited to, the following:
 - a. Flo Fab Inc.
 - b. Miljoco Corporation.
 - c. Palmer Wahl Instrumentation Group.
 - d. Tel-Tru Manufacturing Company.
 - e. Trelice, H. O. Co.
 - f. Weiss Instruments, Inc.
 - g. Winters Instruments - U.S.
 2. Standard: ASME B40.200.
 3. Case: Cast aluminum; 9-inch nominal size unless otherwise indicated.
 4. Case Form: Adjustable angle unless otherwise indicated.
 5. Tube: Glass with magnifying lens and blue or red organic liquid (no mercury).

Weedsport Addition to Maintenance Section and Roof Replacement, MP 304.2

6. Tube Background: Nonreflective aluminum with permanently etched scale markings graduated in deg F.
7. Window: Glass.
8. Stem: Aluminum and of length to suit installation.
 - a. Design for Thermowell Installation: Bare stem.
9. Connector: 1-1/4 inches, with ASME B1.1 screw threads.
10. Accuracy: Plus or minus 1 percent of scale range or one scale division, to a maximum of 1.5 percent of scale range.

2.2 THERMOWELLS**A. Thermowells:**

1. Standard: ASME B40.200.
2. Description: Pressure-tight, socket-type fitting made for insertion into piping tee fitting.
3. Material for Use with Copper Tubing: CNR or CUNI.
4. Type: Stepped shank unless straight or tapered shank is indicated.
5. External Threads: NPS 1/2, NPS 3/4, or NPS 1, ASME B1.20.1 pipe threads.
6. Internal Threads: 1/2, 3/4, and 1 inch, with ASME B1.1 screw threads.
7. Bore: Diameter required to match thermometer bulb or stem.
8. Insertion Length: Length required to match thermometer bulb or stem.
9. Lagging Extension: Include on thermowells for insulated piping and tubing.
10. Bushings: For converting size of thermowell's internal screw thread to size of thermometer connection.

B. Heat-Transfer Medium: Mixture of graphite and glycerin.**2.3 PRESSURE GAGES****A. Direct-Mounted, Metal-Case, Dial-Type Pressure Gages:**

1. Manufacturers: Subject to compliance with requirements, available manufacturers offering products that may be incorporated into the Work include, but are not limited to, the following:
 - a. AMETEK, Inc.; U.S. Gauge.
 - b. Ashcroft Inc.
 - c. Ernst Flow Industries.
 - d. Flo Fab Inc.
 - e. Marsh Bellofram.
 - f. Palmer Wahl Instrumentation Group.
 - g. REOTEMP Instrument Corporation.
 - h. Tel-Tru Manufacturing Company.
 - i. Trelice, H. O. Co.
 - j. Watts Regulator Co.; a div. of Watts Water Technologies, Inc.
 - k. Weiss Instruments, Inc.
 - l. WIKA Instrument Corporation - USA.
 - m. Winters Instruments - U.S.
2. Standard: ASME B40.100.
3. Case: Sealed type(s); cast aluminum or drawn steel; 4-1/2-inch nominal diameter.
4. Pressure-Element Assembly: Bourdon tube unless otherwise indicated.
5. Pressure Connection: Brass, with NPS 1/4 or NPS 1/2, ASME B1.20.1 pipe threads and bottom-outlet type unless back-outlet type is indicated.
6. Movement: Mechanical, with link to pressure element and connection to pointer.

Weedsport Addition to Maintenance Section and Roof Replacement, MP 304.2

7. Dial: Nonreflective aluminum with permanently etched scale markings graduated in psi and kPa.
8. Pointer: Dark-colored metal.
9. Window: Glass.
10. Ring: Metal.
11. Accuracy: Grade B, plus or minus 2 percent of middle half of scale range.

2.4 GAGE ATTACHMENTS

- A. Snubbers: ASME B40.100, brass; with NPS 1/4 or NPS 1/2, ASME B1.20.1 pipe threads and piston-type surge-dampening device. Include extension for use on insulated piping.
- B. Valves: Brass or stainless-steel needle, with NPS 1/4 or NPS 1/2, ASME B1.20.1 pipe threads.

2.5 TEST PLUGS

- A. Manufacturers: Subject to compliance with requirements, available manufacturers offering products that may be incorporated into the Work include, but are not limited to, the following:
 1. Flow Design, Inc.
 2. Miljoco Corporation.
 3. National Meter, Inc.
 4. Peterson Equipment Co., Inc.
 5. Sisco Manufacturing Company, Inc.
 6. Trerice, H. O. Co.
 7. Watts Regulator Co.; a div. of Watts Water Technologies, Inc.
 8. Weiss Instruments, Inc.
- B. Description: Test-station fitting made for insertion into piping tee fitting.
- C. Body: Brass or stainless steel with core inserts and gasketed and threaded cap. Include extended stem on units to be installed in insulated piping.
- D. Thread Size: NPS 1/4 or NPS 1/2, ASME B1.20.1 pipe thread.
- E. Minimum Pressure and Temperature Rating: 500 psig at 200 deg F.
- F. Core Inserts: Chlorosulfonated polyethylene synthetic and EPDM self-sealing rubber.

PART 3 - EXECUTION**3.1 INSTALLATION**

- A. Install thermowells with socket extending one-third of pipe diameter and in vertical position in piping tees.
- B. Install thermowells of sizes required to match thermometer connectors. Include bushings if required to match sizes.
- C. Install thermowells with extension on insulated piping.
- D. Fill thermowells with heat-transfer medium.
- E. Install direct-mounted thermometers in thermowells and adjust vertical and tilted positions.
- F. Install direct-mounted pressure gages in piping tees with pressure gage located on pipe at the most readable position.
- G. Install valve and snubber in piping for each pressure gage for fluids.

Weedsport Addition to Maintenance Section and Roof Replacement, MP 304.2

- H. Install test plugs in piping tees.
- I. Install thermometers in the following locations:
 1. Inlet and outlet of each water heater.
 2. Inlet and outlet of each domestic hot-water storage tank.
- J. Install pressure gages in the following locations:
 1. Building water service entrance into building.
 2. Inlet and outlet of each pressure-reducing valve.
 3. Suction and discharge of each domestic water pump.

3.2 CONNECTIONS

- A. Install meters and gages adjacent to machines and equipment to allow service and maintenance of meters, gages, machines, and equipment.

3.3 ADJUSTING

- A. Adjust faces of meters and gages to proper angle for best visibility.

3.4 THERMOMETER SCHEDULE

- A. Thermometers at inlet and outlet of each domestic water heater and storage tank shall be one of the following:
 1. Liquid-filled, bimetallic-actuated type.
 2. Direct-mounted, metal-case, vapor-actuated type.
 3. Industrial-style, liquid-in-glass type.
 4. Direct-mounted, light-activated type.
 5. Test plug with EPDM self-sealing rubber inserts.
- B. Thermometer stems shall be of length to match thermowell insertion length.

3.5 THERMOMETER SCALE-RANGE SCHEDULE

- A. Scale Range for Domestic Cold-Water Piping: 0 to 150 deg F.
- B. Scale Range for Domestic Hot-Water Piping: 0 to 250 deg F.

3.6 PRESSURE-GAGE SCHEDULE

- A. Pressure gages at discharge of each water service into building shall be the following:
 1. Sealed, direct-mounted, metal case.
 2. Test plug with EPDM self-sealing rubber inserts.
- B. Pressure gages at inlet and outlet of each water pressure-reducing valve shall be the following:
 1. Sealed, direct-mounted, metal case.
 2. Test plug with EPDM self-sealing rubber inserts.
- C. Pressure gages at suction and discharge of each domestic water pump shall be the following:
 1. Sealed, direct-mounted, metal case.
 2. Test plug with EPDM self-sealing rubber inserts.

3.7 PRESSURE-GAGE SCALE-RANGE SCHEDULE

- A. Scale Range for Water Service Piping: 0 to 200 psi and 0 to 1400 kPa.
- B. Scale Range for Domestic Water Piping: 0 to 200 psi and 0 to 1400 kPa.

END OF SECTION 220519

SECTION 220523 - GENERAL-DUTY VALVES FOR PLUMBING PIPING

PART 1 - GENERAL

1.1 RELATED DOCUMENTS

- A. Drawings and general provisions of the Contract, including General and Supplementary Conditions and Division 01 Specification Sections, apply to this Section.

1.2 SUMMARY

- A. Section Includes:
 - 1. Bronze ball valves.
 - 2. Iron, single-flange butterfly valves.
 - 3. Iron, grooved-end butterfly valves.
 - 4. Bronze swing check valves.
 - 5. Iron gate valves.
 - 6. Lubricated plug valves.

1.3 DEFINITIONS

- A. CWP: Cold working pressure.
- B. EPDM: Ethylene propylene copolymer rubber.
- C. NBR: Acrylonitrile-butadiene, Buna-N, or nitrile rubber.
- D. NRS: Nonrising stem.
- E. OS&Y: Outside screw and yoke.
- F. RS: Rising stem.
- G. SWP: Steam working pressure.

1.4 ACTION SUBMITTALS

- A. Product Data: For each type of valve indicated.

1.5 QUALITY ASSURANCE

- A. Source Limitations for Valves: Obtain each type of valve from single source from single manufacturer.
- B. ASME Compliance:
 - 1. ASME B16.10 and ASME B16.34 for ferrous valve dimensions and design criteria.
 - 2. ASME B31.1 for power piping valves.
 - 3. ASME B31.9 for building services piping valves.
- C. NSF Compliance: NSF 61 and NSF 372 for valve materials for potable-water service.

1.6 DELIVERY, STORAGE, AND HANDLING

- A. Prepare valves for shipping as follows:
 - 1. Protect internal parts against rust and corrosion.
 - 2. Protect threads, flange faces, grooves, and weld ends.
 - 3. Set angle, gate, and globe valves closed to prevent rattling.

Weedsport Addition to Maintenance Section and Roof Replacement, MP 304.2

4. Set ball and plug valves open to minimize exposure of functional surfaces.
 5. Set butterfly valves closed or slightly open.
 6. Block check valves in either closed or open position.
- B. Use the following precautions during storage:
1. Maintain valve end protection.
 2. Store valves indoors and maintain at higher than ambient dew point temperature. If outdoor storage is necessary, store valves off the ground in watertight enclosures.

PART 2 - PRODUCTS

2.1 GENERAL REQUIREMENTS FOR VALVES

- A. Refer to valve schedule articles for applications of valves.
- B. Per new Federal Lead Free Law, any product designed for dispensing potable water meet both the NSF 61 and NSF 372 test standards via third-party testing and certification.
- C. Valve Pressure and Temperature Ratings: Not less than indicated and as required for system pressures and temperatures.
- D. Valve Sizes: Same as upstream piping unless otherwise indicated.
- E. Valve Actuator Types:
1. Gear Actuator: For quarter-turn valves NPS 8 and larger.
 2. Handwheel: For valves other than quarter-turn types.
 3. Handlever: For quarter-turn valves NPS 6 and smaller.
 4. Wrench: For plug valves with square heads. Furnish Owner with 1 wrench for every 5 plug valves, for each size square plug-valve head.
- F. Valves in Insulated Piping: With 2-inch stem extensions and the following features:
1. Gate Valves: With rising stem.
 2. Ball Valves: With extended operating handle of non-thermal-conductive material, and protective sleeve that allows operation of valve without breaking the vapor seal or disturbing insulation.
 3. Butterfly Valves: With extended neck.
- G. Valve-End Connections:
1. Flanged: With flanges according to ASME B16.1 for iron valves.
 2. Grooved: With grooves according to AWWA C606.
 3. Solder Joint: With sockets according to ASME B16.18.
 4. Threaded: With threads according to ASME B1.20.1.
- H. Valve Bypass and Drain Connections: MSS SP-45.

2.2 BRONZE BALL VALVES

- A. Two-Piece, Full-Port, Bronze Ball Valves with Bronze Trim:
1. Manufacturers: Subject to compliance with requirements, available manufacturers offering products that may be incorporated into the Work include, but are not limited to, the following:
 - a. American Valve, Inc.
 - b. Conbraco Industries, Inc.; Apollo Valves.
 - c. Crane Co.; Crane Valve Group; Crane Valves.
 - d. Hammond Valve.

Weedsport Addition to Maintenance Section and Roof Replacement, MP 304.2

- e. Lance Valves; a division of Advanced Thermal Systems, Inc.
 - f. Milwaukee Valve Company.
 - g. NIBCO INC.
 - h. Red-White Valve Corporation.
 - i. Watts Regulator Co.; a division of Watts Water Technologies, Inc.
2. Description:
- a. Standard: MSS SP-110.
 - b. SWP Rating: 150 psig.
 - c. CWP Rating: 600 psig.
 - d. Body Design: Two piece.
 - e. Body Material: Bronze.
 - f. Ends: Threaded.
 - g. Seats: PTFE or TFE.
 - h. Stem: Bronze.
 - i. Ball: Chrome-plated brass.
 - j. Port: Full.

2.3 IRON, SINGLE-FLANGE BUTTERFLY VALVES

- A. 200 CWP, Iron, Single-Flange Butterfly Valves with EPDM Seat and Aluminum-Bronze Disc:
- 1. Manufacturers: Subject to compliance with requirements, available manufacturers offering products that may be incorporated into the Work include, but are not limited to, the following:
 - a. Conbraco Industries, Inc.; Apollo Valves.
 - b. Cooper Cameron Valves; a division of Cooper Cameron Corporation.
 - c. Crane Co.; Crane Valve Group; Jenkins Valves.
 - d. Crane Co.; Crane Valve Group; Stockham Division.
 - e. DeZurik Water Controls.
 - f. Flo Fab Inc.
 - g. Hammond Valve.
 - h. Kitz Corporation.
 - i. Milwaukee Valve Company.
 - j. NIBCO INC.
 - k. Red-White Valve Corporation.
 - l. Watts Regulator Co.; a division of Watts Water Technologies, Inc.
 - 2. Description:
 - a. Standard: MSS SP-67, Type I.
 - b. CWP Rating: 200 psig.
 - c. Body Design: Lug type; suitable for bidirectional dead-end service at rated pressure without use of downstream flange.
 - d. Body Material: ASTM A 126, cast iron or ASTM A 536, ductile iron.
 - e. Seat: EPDM.
 - f. Stem: One- or two-piece stainless steel.
 - g. Disc: Aluminum bronze.

2.4 IRON, GROOVED-END BUTTERFLY VALVES

- A. 175 CWP, Iron, Grooved-End Butterfly Valves:
- 1. Manufacturers: Subject to compliance with requirements, available manufacturers offering products that may be incorporated into the Work include, but are not limited to, the following:

Weedsport Addition to Maintenance Section and Roof Replacement, MP 304.2

- a. Kennedy Valve; a division of McWane, Inc.
 - b. Shurjoint Piping Products.
 - c. Tyco Fire Products LP; Grinnell Mechanical Products.
 - d. Victaulic Company.
2. Description:
- a. Standard: MSS SP-67, Type I.
 - b. CWP Rating: 175 psig.
 - c. Body Material: Coated, ductile iron.
 - d. Stem: Two-piece stainless steel.
 - e. Disc: Coated, ductile iron.
 - f. Seal: EPDM.

2.5 BRONZE SWING CHECK VALVES

- A. Class 125, Bronze Swing Check Valves with Bronze Disc:
- 1. Manufacturers: Subject to compliance with requirements, available manufacturers offering products that may be incorporated into the Work include, but are not limited to, the following:
 - a. American Valve, Inc.
 - b. Crane Co.; Crane Valve Group; Crane Valves.
 - c. Crane Co.; Crane Valve Group; Jenkins Valves.
 - d. Crane Co.; Crane Valve Group; Stockham Division.
 - e. Hammond Valve.
 - f. Kitz Corporation.
 - g. Milwaukee Valve Company.
 - h. NIBCO INC.
 - i. Red-White Valve Corporation.
 - j. Watts Regulator Co.; a division of Watts Water Technologies, Inc.
 - 2. Description:
 - a. Standard: MSS SP-80, Type 3.
 - b. CWP Rating: 200 psig.
 - c. Body Design: Horizontal flow.
 - d. Body Material: ASTM B 62, bronze.
 - e. Ends: Threaded.
 - f. Disc: Bronze.

2.6 IRON GATE VALVES

- A. Class 125, OS&Y, Iron Gate Valves:
- 1. Manufacturers: Subject to compliance with requirements, available manufacturers offering products that may be incorporated into the Work include, but are not limited to, the following:
 - a. Crane Co.; Crane Valve Group; Crane Valves.
 - b. Crane Co.; Crane Valve Group; Jenkins Valves.
 - c. Crane Co.; Crane Valve Group; Stockham Division.
 - d. Hammond Valve.
 - e. Kitz Corporation.
 - f. Milwaukee Valve Company.
 - g. NIBCO INC.
 - h. Powell Valves.
 - i. Red-White Valve Corporation.

Weedsport Addition to Maintenance Section and Roof Replacement, MP 304.2

- j. Watts Regulator Co.; a division of Watts Water Technologies, Inc.
- 2. Description:
 - a. Standard: MSS SP-70, Type I.
 - b. CWP Rating: 200 psig.
 - c. Body Material: ASTM A 126, gray iron with bolted bonnet.
 - d. Ends: Flanged.
 - e. Trim: Bronze.
 - f. Disc: Solid wedge.
 - g. Packing and Gasket: Asbestos free.

2.7 LUBRICATED PLUG VALVES

- A. Class 125, Regular-Gland, Lubricated Plug Valves with Threaded Ends:
 - 1. Manufacturers: Subject to compliance with requirements, available manufacturers offering products that may be incorporated into the Work include, but are not limited to, the following:
 - a. Nordstrom Valves, Inc.
 - 2. Description:
 - a. Standard: MSS SP-78, Type II.
 - b. CWP Rating: 200 psig.
 - c. Body Material: ASTM A 48/A 48M or ASTM A 126, cast iron with lubrication-sealing system.
 - d. Pattern: Regular or short.
 - e. Plug: Cast iron or bronze with sealant groove.
- B. Class 125, Lubricated Plug Valves with Flanged Ends:
 - 1. Manufacturers: Subject to compliance with requirements, available manufacturers offering products that may be incorporated into the Work include, but are not limited to, the following:
 - a. Nordstrom Valves, Inc.
 - 2. Description:
 - a. Standard: MSS SP-78, Type II.
 - b. CWP Rating: 200 psig.
 - c. Body Material: ASTM A 48/A 48M or ASTM A 126, cast iron with lubrication-sealing system.
 - d. Pattern: Regular or short.
 - e. Plug: Cast iron or bronze with sealant groove.

PART 3 - EXECUTION**3.1 EXAMINATION**

- A. Examine valve interior for cleanliness, freedom from foreign matter, and corrosion. Remove special packing materials, such as blocks, used to prevent disc movement during shipping and handling.
- B. Operate valves in positions from fully open to fully closed. Examine guides and seats made accessible by such operations.
- C. Examine threads on valve and mating pipe for form and cleanliness.

Weedsport Addition to Maintenance Section and Roof Replacement, MP 304.2

- D. Examine mating flange faces for conditions that might cause leakage. Check bolting for proper size, length, and material. Verify that gasket is of proper size, that its material composition is suitable for service, and that it is free from defects and damage.
- E. Do not attempt to repair defective valves; replace with new valves.

3.2 VALVE INSTALLATION

- A. Install valves with unions or flanges at each piece of equipment arranged to allow service, maintenance, and equipment removal without system shutdown.
- B. Locate valves for easy access and provide separate support where necessary.
- C. Install valves in horizontal piping with stem at or above center of pipe.
- D. Install valves in position to allow full stem movement.
- E. Install check valves for proper direction of flow and as follows:
 1. Swing Check Valves: In horizontal position with hinge pin level.

3.3 ADJUSTING

- A. Adjust or replace valve packing after piping systems have been tested and put into service but before final adjusting and balancing. Replace valves if persistent leaking occurs.

3.4 GENERAL REQUIREMENTS FOR VALVE APPLICATIONS

- A. If valve applications are not indicated, use the following:
 1. Shutoff Service: Ball, butterfly valves.
 2. Butterfly Valve Dead-End Service: Single-flange (lug) type.
 3. Throttling Service: ball, or butterfly valves.
 4. Pump-Discharge Check Valves:
 - a. NPS 2 and Smaller: Bronze swing check valves with bronze disc.
 - b. NPS 2-1/2 and Larger for Domestic Water: Iron swing check valves with lever and weight or with spring or iron, center-guided, resilient-seat check valves.
 - c. NPS 2-1/2 and Larger for Sanitary Waste and Storm Drainage: Iron swing check valves with lever and weight or spring.
- B. If valves with specified SWP classes or CWP ratings are not available, the same types of valves with higher SWP classes or CWP ratings may be substituted.
- C. Select valves, except wafer types, with the following end connections:
 1. For Copper Tubing, NPS 2 and Smaller: Threaded ends except where solder-joint valve-end option is indicated in valve schedules below.
 2. For Copper Tubing, NPS 2-1/2 to NPS 4: Flanged ends except where threaded valve-end option is indicated in valve schedules below.
 3. For Copper Tubing, NPS 5 and Larger: Flanged ends.
 4. For Grooved-End Copper Tubing: Valve ends may be grooved.

3.5 DOMESTIC, HOT- AND COLD-WATER VALVE SCHEDULE

- A. Pipe NPS 2 and Smaller:
 1. Bronze Valves: May be provided with solder-joint ends instead of threaded ends.
 2. Ball Valves: Two piece, full port, bronze with bronze trim.
 3. Bronze Swing Check Valves: Class 125, bronze disc.
- B. Pipe NPS 2-1/2 and Larger:

Weedsport Addition to Maintenance Section and Roof Replacement, MP 304.2

1. Iron Valves, NPS 2-1/2 to NPS 4: May be provided with threaded ends instead of flanged ends.
2. Iron Ball Valves: Class 150.
3. Iron, Single-Flange Butterfly Valves: 200 CWP, EPDM seat, aluminum-bronze disc.
4. Iron, Grooved-End Butterfly Valves: 175 CWP.
5. Iron Swing Check Valves: Class 125, nonmetallic-to-metal seats.
6. Iron Gate Valves: Class 125, OS&Y.

3.6 SANITARY-WASTE AND STORM-DRAINAGE VALVE SCHEDULE

- A. Pipe NPS 2 and Smaller:
 1. Bronze Swing Check Valves: Class 125, bronze disc.
- B. Pipe NPS 2-1/2 and Larger:
 1. Iron Swing Check Valves: Class 125, nonmetallic-to-metal seats.

END OF SECTION 220523

SECTION 220529 - HANGERS AND SUPPORTS FOR PLUMBING PIPING

PART 1 - GENERAL**1.1 RELATED DOCUMENTS**

- A. Drawings and general provisions of the Contract, including General and Supplementary Conditions and Division 01 Specification Sections, apply to this Section.

1.2 SUMMARY

- A. Section Includes:
1. Metal pipe hangers and supports.
 2. Trapeze pipe hangers.
 3. Thermal-hanger shield inserts.
 4. Fastener systems.
 5. Pipe stands.
 6. Equipment supports.

1.3 DEFINITIONS

- A. MSS: Manufacturers Standardization Society of The Valve and Fittings Industry Inc.

1.4 PERFORMANCE REQUIREMENTS

- A. Delegated Design: Design trapeze pipe hangers and equipment supports, including comprehensive engineering analysis by a qualified professional engineer, using performance requirements and design criteria indicated.
- B. Structural Performance: Hangers and supports for plumbing piping and equipment shall withstand the effects of gravity loads and stresses within limits and under conditions indicated according to ASCE/SEI 7.
1. Design supports for multiple pipes, including pipe stands, capable of supporting combined weight of supported systems, system contents, and test water.
 2. Design equipment supports capable of supporting combined operating weight of supported equipment and connected systems and components.

1.5 ACTION SUBMITTALS

- A. Product Data: For each type of product indicated.
- B. Shop Drawings: Show fabrication and installation details and include calculations for the following: include Product Data for components:
1. Trapeze pipe hangers.
 2. Metal framing systems.
 3. Pipe stands.
 4. Equipment supports.
- C. Delegated-Design Submittal: For trapeze hangers indicated to comply with performance requirements and design criteria, including analysis data signed and sealed by the qualified professional engineer responsible for their preparation.
1. Detail fabrication and assembly of trapeze hangers.
 2. Design Calculations: Calculate requirements for designing trapeze hangers.

Weedsport Addition to Maintenance Section and Roof Replacement, MP 304.2

1.6 INFORMATIONAL SUBMITTALS

- A. Welding certificates.

1.7 QUALITY ASSURANCE

- A. Structural Steel Welding Qualifications: Qualify procedures and personnel according to AWS D1.1/D1.1M, "Structural Welding Code - Steel."
- B. Pipe Welding Qualifications: Qualify procedures and operators according to ASME Boiler and Pressure Vessel Code.

PART 2 - PRODUCTS**2.1 METAL PIPE HANGERS AND SUPPORTS**

- A. Carbon-Steel Pipe Hangers and Supports:
 1. Description: MSS SP-58, Types 1 through 58, factory-fabricated components.
 2. Galvanized Metallic Coatings: Pregalvanized or hot dipped.
 3. Nonmetallic Coatings: Plastic coating, jacket, or liner.
 4. Padded Hangers: Hanger with fiberglass or other pipe insulation pad or cushion to support bearing surface of piping.
 5. Hanger Rods: Continuous-thread rod, nuts, and washer made of carbon steel.
- B. Copper Pipe Hangers:
 1. Description: MSS SP-58, Types 1 through 58, copper-coated-steel, factory-fabricated components.
 2. Hanger Rods: Continuous-thread rod, nuts, and washer made of copper-coated steel.

2.2 TRAPEZE PIPE HANGERS

- A. Description: MSS SP-69, Type 59, shop- or field-fabricated pipe-support assembly made from structural carbon-steel shapes with MSS SP-58 carbon-steel hanger rods, nuts, saddles, and U-bolts.

2.3 THERMAL-HANGER SHIELD INSERTS

- A. Manufacturers: Subject to compliance with requirements, available manufacturers offering products that may be incorporated into the Work include, but are not limited to, the following:
 1. Carpenter & Paterson, Inc.
 2. Clement Support Services.
 3. ERICO International Corporation.
 4. National Pipe Hanger Corporation.
 5. PHS Industries, Inc.
 6. Pipe Shields, Inc.; a subsidiary of Piping Technology & Products, Inc.
 7. Piping Technology & Products, Inc.
 8. Rilco Manufacturing Co., Inc.
 9. Value Engineered Products, Inc.
- B. Insulation-Insert Material for Cold Piping: ASTM C 552, Type II cellular glass with 100-psig minimum compressive strength and vapor barrier.
- C. Insulation-Insert Material for Hot Piping: ASTM C 552, Type II cellular glass with 100-psig minimum compressive strength.

Weedsport Addition to Maintenance Section and Roof Replacement, MP 304.2

- D. For Trapeze or Clamped Systems: Insert and shield shall cover entire circumference of pipe.
- E. For Clevis or Band Hangers: Insert and shield shall cover lower 180 degrees of pipe.
- F. Insert Length: Extend 2 inches beyond sheet metal shield for piping operating below ambient air temperature.

2.4 FASTENER SYSTEMS

- A. Powder-Actuated Fasteners: Threaded-steel stud, for use in hardened portland cement concrete with pull-out, tension, and shear capacities appropriate for supported loads and building materials where used.
- B. Mechanical-Expansion Anchors: Insert-wedge-type, zinc-coated steel anchors, for use in hardened portland cement concrete; with pull-out, tension, and shear capacities appropriate for supported loads and building materials where used.

2.5 PIPE STANDS

- A. General Requirements for Pipe Stands: Shop- or field-fabricated assemblies made of manufactured corrosion-resistant components to support roof-mounted piping.
- B. Compact Pipe Stand: One-piece plastic unit with integral-rod roller, pipe clamps, or V-shaped cradle to support pipe, for roof installation without membrane penetration.
- C. Low-Type, Single-Pipe Stand: One-piece plastic base unit with plastic roller, for roof installation without membrane penetration.
- D. High-Type, Single-Pipe Stand:
 - 1. Description: Assembly of base, vertical and horizontal members, and pipe support, for roof installation without membrane penetration.
 - 2. Base: Plastic.
 - 3. Vertical Members: Two or more cadmium-plated-steel or stainless-steel, continuous-thread rods.
 - 4. Horizontal Member: Cadmium-plated-steel or stainless-steel rod with plastic or stainless-steel, roller-type pipe support.
- E. High-Type, Multiple-Pipe Stand:
 - 1. Description: Assembly of bases, vertical and horizontal members, and pipe supports, for roof installation without membrane penetration.
 - 2. Bases: One or more; plastic.
 - 3. Vertical Members: Two or more protective-coated-steel channels.
 - 4. Horizontal Member: Protective-coated-steel channel.
 - 5. Pipe Supports: Galvanized-steel, clevis-type pipe hangers.

2.6 EQUIPMENT SUPPORTS

- A. Description: Welded, shop- or field-fabricated equipment support made from structural carbon-steel shapes.

2.7 MISCELLANEOUS MATERIALS

- A. Structural Steel: ASTM A 36/A 36M, carbon-steel plates, shapes, and bars; black and galvanized.
- B. Grout: ASTM C 1107, factory-mixed and -packaged, dry, hydraulic-cement, nonshrink and nonmetallic grout; suitable for interior and exterior applications.

Weedsport Addition to Maintenance Section and Roof Replacement, MP 304.2

1. Properties: Nonstaining, noncorrosive, and nongaseous.
2. Design Mix: 5000-psi, 28-day compressive strength.

PART 3 - EXECUTION**3.1 HANGER AND SUPPORT INSTALLATION**

- A. Metal Pipe-Hanger Installation: Comply with MSS SP-69 and MSS SP-89. Install hangers, supports, clamps, and attachments as required to properly support piping from the building structure.
- B. Metal Trapeze Pipe-Hanger Installation: Comply with MSS SP-69 and MSS SP-89. Arrange for grouping of parallel runs of horizontal piping, and support together on field-fabricated trapeze pipe hangers.
 1. Pipes of Various Sizes: Support together and space trapezes for smallest pipe size or install intermediate supports for smaller diameter pipes as specified for individual pipe hangers.
 2. Field fabricate from ASTM A 36/A 36M, carbon-steel shapes selected for loads being supported. Weld steel according to AWS D1.1/D1.1M.
- C. Thermal-Hanger Shield Installation: Install in pipe hanger or shield for insulated piping.
- D. Fastener System Installation:
 1. Install powder-actuated fasteners for use in lightweight concrete or concrete slabs less than 4 inches thick in concrete after concrete is placed and completely cured. Use operators that are licensed by powder-actuated tool manufacturer. Install fasteners according to powder-actuated tool manufacturer's operating manual.
 2. Install mechanical-expansion anchors in concrete after concrete is placed and completely cured. Install fasteners according to manufacturer's written instructions.
- E. Pipe Stand Installation:
 1. Pipe Stand Types except Curb-Mounted Type: Assemble components and mount on smooth roof surface. Do not penetrate roof membrane.
- F. Install hangers and supports complete with necessary attachments, inserts, bolts, rods, nuts, washers, and other accessories.
- G. Equipment Support Installation: Fabricate from welded-structural-steel shapes.
- H. Install hangers and supports to allow controlled thermal movement of piping systems, to permit freedom of movement between pipe anchors, and to facilitate action of expansion joints, expansion loops, expansion bends, and similar units.
- I. Install lateral bracing with pipe hangers and supports to prevent swaying.
- J. Install building attachments within concrete slabs or attach to structural steel. Install additional attachments at concentrated loads, including valves, flanges, and strainers, NPS 2-1/2 and larger and at changes in direction of piping. Install concrete inserts before concrete is placed; fasten inserts to forms and install reinforcing bars through openings at top of inserts.
- K. Load Distribution: Install hangers and supports so that piping live and dead loads and stresses from movement will not be transmitted to connected equipment.
- L. Pipe Slopes: Install hangers and supports to provide indicated pipe slopes and to not exceed maximum pipe deflections allowed by ASME B31.9 for building services piping.
- M. Insulated Piping:

Weedsport Addition to Maintenance Section and Roof Replacement, MP 304.2

1. Attach clamps and spacers to piping.
 - a. Piping Operating above Ambient Air Temperature: Clamp may project through insulation.
 - b. Piping Operating below Ambient Air Temperature: Use thermal-hanger shield insert with clamp sized to match OD of insert.
 - c. Do not exceed pipe stress limits allowed by ASME B31.9 for building services piping.
2. Install MSS SP-58, Type 39, protection saddles if insulation without vapor barrier is indicated. Fill interior voids with insulation that matches adjoining insulation.
 - a. Option: Thermal-hanger shield inserts may be used. Include steel weight-distribution plate for pipe NPS 4 and larger if pipe is installed on rollers.
3. Install MSS SP-58, Type 40, protective shields on cold piping with vapor barrier. Shields shall span an arc of 180 degrees.
 - a. Option: Thermal-hanger shield inserts may be used. Include steel weight-distribution plate for pipe NPS 4 and larger if pipe is installed on rollers.
4. Shield Dimensions for Pipe: Not less than the following:
 - a. NPS 1/4 to NPS 3-1/2: 12 inches long and 0.048 inch thick.
 - b. NPS 4: 12 inches long and 0.06 inch thick.
 - c. NPS 5 and NPS 6: 18 inches long and 0.06 inch thick.
 - d. NPS 8 to NPS 14: 24 inches long and 0.075 inch thick.
 - e. NPS 16 to NPS 24: 24 inches long and 0.105 inch thick.
5. Pipes NPS 8 and Larger: Include wood or reinforced calcium-silicate-insulation inserts of length at least as long as protective shield.
6. Thermal-Hanger Shields: Install with insulation same thickness as piping insulation.

3.2 EQUIPMENT SUPPORTS

- A. Fabricate structural-steel stands to suspend equipment from structure overhead or to support equipment above floor.
- B. Grouting: Place grout under supports for equipment and make bearing surface smooth.
- C. Provide lateral bracing, to prevent swaying, for equipment supports.

3.3 METAL FABRICATIONS

- A. Cut, drill, and fit miscellaneous metal fabrications for trapeze pipe hangers and equipment supports.
- B. Fit exposed connections together to form hairline joints. Field weld connections that cannot be shop welded because of shipping size limitations.
- C. Field Welding: Comply with AWS D1.1/D1.1M procedures for shielded, metal arc welding; appearance and quality of welds; and methods used in correcting welding work; and with the following:
 1. Use materials and methods that minimize distortion and develop strength and corrosion resistance of base metals.
 2. Obtain fusion without undercut or overlap.
 3. Remove welding flux immediately.
 4. Finish welds at exposed connections so no roughness shows after finishing and so contours of welded surfaces match adjacent contours.

Weedsport Addition to Maintenance Section and Roof Replacement, MP 304.2

3.4 ADJUSTING

- A. Hanger Adjustments: Adjust hangers to distribute loads equally on attachments and to achieve indicated slope of pipe.
- B. Trim excess length of continuous-thread hanger and support rods to 1-1/2 inches.

3.5 PAINTING

- A. Touchup: Clean field welds and abraded areas of shop paint. Paint exposed areas immediately after erecting hangers and supports. Use same materials as used for shop painting. Comply with SSPC-PA 1 requirements for touching up field-painted surfaces.
 - 1. Apply paint by brush or spray to provide a minimum dry film thickness of 2.0 mils.
- B. Touchup: Cleaning and touchup painting of field welds, bolted connections, and abraded areas of shop paint on miscellaneous metal are specified in Section 09
- C. Galvanized Surfaces: Clean welds, bolted connections, and abraded areas and apply galvanizing-repair paint to comply with ASTM A 780.

3.6 HANGER AND SUPPORT SCHEDULE

- A. Specific hanger and support requirements are in Sections specifying piping systems and equipment.
- B. Comply with MSS SP-69 for pipe-hanger selections and applications that are not specified in piping system Sections.
- C. Use hangers and supports with galvanized metallic coatings for piping and equipment that will not have field-applied finish.
- D. Use nonmetallic coatings on attachments for electrolytic protection where attachments are in direct contact with copper tubing.
- E. Use carbon-steel pipe hangers and supports, metal trapeze pipe hangers and metal framing systems and attachments for general service applications.
- F. Use copper-plated pipe hangers and copper attachments for copper piping and tubing.
- G. Use thermal-hanger shield inserts for insulated piping and tubing.
- H. Horizontal-Piping Hangers and Supports: Unless otherwise indicated and except as specified in piping system Sections, install the following types:
 - 1. Adjustable, Steel Clevis Hangers (MSS Type 1): For suspension of noninsulated or insulated, stationary pipes NPS 1/2 to NPS 30.
 - 2. Steel Pipe Clamps (MSS Type 4): For suspension of cold and hot pipes NPS 1/2 to NPS 24 if little or no insulation is required.
 - 3. Clips (MSS Type 26): For support of insulated pipes not subject to expansion or contraction.
 - 4. Single-Pipe Rolls (MSS Type 41): For suspension of pipes NPS 1 to NPS 30, from two rods if longitudinal movement caused by expansion and contraction might occur.
- I. Vertical-Piping Clamps: Unless otherwise indicated and except as specified in piping system Sections, install the following types:
 - 1. Extension Pipe or Riser Clamps (MSS Type 8): For support of pipe risers NPS 3/4 to NPS 24.
 - 2. Carbon- or Alloy-Steel Riser Clamps (MSS Type 42): For support of pipe risers NPS 3/4 to NPS 24 if longer ends are required for riser clamps.

Weedsport Addition to Maintenance Section and Roof Replacement, MP 304.2

- J. Hanger-Rod Attachments: Unless otherwise indicated and except as specified in piping system Sections, install the following types:
1. Steel Turnbuckles (MSS Type 13): For adjustment up to 6 inches for heavy loads.
 2. Steel Clevises (MSS Type 14): For 120 to 450 deg F piping installations.
 3. Steel Weldless Eye Nuts (MSS Type 17): For 120 to 450 deg F piping installations.
- K. Building Attachments: Unless otherwise indicated and except as specified in piping system Sections, install the following types:
1. Steel or Malleable Concrete Inserts (MSS Type 18): For upper attachment to suspend pipe hangers from concrete ceiling.
 2. Top-Beam C-Clamps (MSS Type 19): For use under roof installations with bar-joist construction, to attach to top flange of structural shape.
 3. Side-Beam or Channel Clamps (MSS Type 20): For attaching to bottom flange of beams, channels, or angles.
 4. Side-Beam Clamps (MSS Type 27): For bottom of steel I-beams.
 5. Steel-Beam Clamps with Eye Nuts (MSS Type 28): For attaching to bottom of steel I-beams for heavy loads.
 6. Horizontal Travelers (MSS Type 58): For supporting piping systems subject to linear horizontal movement where headroom is limited.
- L. Saddles and Shields: Unless otherwise indicated and except as specified in piping system Sections, install the following types:
1. Steel-Pipe-Covering Protection Saddles (MSS Type 39): To fill interior voids with insulation that matches adjoining insulation.
 2. Protection Shields (MSS Type 40): Of length recommended in writing by manufacturer to prevent crushing insulation.
 3. Thermal-Hanger Shield Inserts: For supporting insulated pipe.
- M. Comply with MSS SP-69 for trapeze pipe-hanger selections and applications that are not specified in piping system Sections.
- N. Use powder-actuated fasteners instead of building attachments where required in concrete construction.
- O. Use pipe positioning systems in pipe spaces behind plumbing fixtures to support supply and waste piping for plumbing fixtures.

END OF SECTION 220529

SECTION 220719 - PLUMBING PIPING INSULATION

PART 1 - GENERAL

1.1 RELATED DOCUMENTS

- A. Drawings and general provisions of the Contract, including General and Supplementary Conditions and Division 01 Specification Sections, apply to this Section.

1.2 SUMMARY

- A. Section includes insulating the following plumbing piping services:
1. Domestic cold-water piping.
 2. Domestic hot-water piping.
 3. Domestic recirculating hot-water piping.
 4. Roof drains and rainwater leaders.
 5. Supplies and drains for handicap-accessible lavatories and sinks.

1.3 ACTION SUBMITTALS

- A. Product Data: For each type of product indicated. Include thermal conductivity, water-vapor permeance thickness, and jackets (both factory- and field-applied, if any).
- B. Shop Drawings: Include plans, elevations, sections, details, and attachments to other work.
1. Detail application of protective shields, saddles, and inserts at hangers for each type of insulation and hanger.
 2. Detail insulation application at elbows, fittings, flanges, valves, and specialties for each type of insulation.
 3. Detail application of field-applied jackets.

1.4 INFORMATIONAL SUBMITTALS

- A. Qualification Data: For qualified Installer.
- B. Material Test Reports: From a qualified testing agency acceptable to authorities having jurisdiction indicating, interpreting, and certifying test results for compliance of insulation materials, sealers, attachments, cements, and jackets, with requirements indicated. Include dates of tests and test methods employed.
- C. Field quality-control reports.

1.5 QUALITY ASSURANCE

- A. Surface-Burning Characteristics: For insulation and related materials, as determined by testing identical products according to ASTM E 84 by a testing agency acceptable to authorities having jurisdiction. Factory label insulation and jacket materials and adhesive, mastic, tapes, and cement material containers, with appropriate markings of applicable testing agency.
1. Insulation Installed Indoors: Flame-spread index of 25 or less, and smoke-developed index of 50 or less.
 2. Insulation Installed Outdoors: Flame-spread index of 75 or less, and smoke-developed index of 150 or less.
- B. Comply with the following applicable standards and other requirements specified for miscellaneous components:
1. Supply and Drain Protective Shielding Guards: ICC A117.1.

Weedsport Addition to Maintenance Section and Roof Replacement, MP 304.2

1.6 DELIVERY, STORAGE, AND HANDLING

- A. Packaging: Insulation material containers shall be marked by manufacturer with appropriate ASTM standard designation, type and grade, and maximum use temperature.

1.7 COORDINATION

- A. Coordinate sizes and locations of supports, hangers, and insulation shields specified in Section 220529 "Hangers and Supports for Plumbing Piping and Equipment."
- B. Coordinate clearance requirements with piping Installer for piping insulation application. Before preparing piping Shop Drawings, establish and maintain clearance requirements for installation of insulation and field-applied jackets and finishes and for space required for maintenance.
- C. Coordinate installation and testing of heat tracing.

1.8 SCHEDULING

- A. Schedule insulation application after pressure testing systems and, where required, after installing and testing heat tracing. Insulation application may begin on segments that have satisfactory test results.
- B. Complete installation and concealment of plastic materials as rapidly as possible in each area of construction.

PART 2 - PRODUCTS**2.1 INSULATION MATERIALS**

- A. Comply with requirements in "Piping Insulation Schedule, General," "Indoor Piping Insulation Schedule," "Outdoor, Aboveground Piping Insulation Schedule," and "Outdoor, Underground Piping Insulation Schedule" articles for where insulating materials shall be applied.
- B. Products shall not contain asbestos, lead, mercury, or mercury compounds.
- C. Products that come in contact with stainless steel shall have a leachable chloride content of less than 50 ppm when tested according to ASTM C 871.
- D. Insulation materials for use on austenitic stainless steel shall be qualified as acceptable according to ASTM C 795.
- E. Foam insulation materials shall not use CFC or HCFC blowing agents in the manufacturing process.
- F. Flexible Elastomeric Insulation: Closed-cell, sponge- or expanded-rubber materials. Comply with ASTM C 534, Type I for tubular materials.
 - 1. Products: Subject to compliance with requirements, available products that may be incorporated into the Work include, but are not limited to, the following:
 - a. Aeroflex USA, Inc.; Aerocel.
 - b. Armacell LLC; AP Armaflex.
 - c. K-Flex USA; Insul-Lock, Insul-Tube, and K-FLEX LS.
- G. Mineral-Fiber, Preformed Pipe Insulation:
 - 1. Products: Subject to compliance with requirements, available products that may be incorporated into the Work include, but are not limited to, the following:
 - a. Fibrex Insulations Inc.; Coreplus 1200.
 - b. Johns Manville; Micro-Lok.

Weedsport Addition to Maintenance Section and Roof Replacement, MP 304.2

- c. Knauf Insulation; 1000-Degree Pipe Insulation.
 - d. Manson Insulation Inc.; Alley-K.
 - e. Owens Corning; Fiberglas Pipe Insulation.
2. Type I, 850 Deg F Materials: Mineral or glass fibers bonded with a thermosetting resin. Comply with ASTM C 547, Type I, Grade A, with factory-applied ASJ. Factory-applied jacket requirements are specified in "Factory-Applied Jackets" Article.

2.2 INSULATING CEMENTS

- A. Mineral-Fiber Insulating Cement: Comply with ASTM C 195.
- 1. Products: Subject to compliance with requirements, available products that may be incorporated into the Work include, but are not limited to, the following:
 - a. Ramco Insulation, Inc.; Super-Stik.

2.3 ADHESIVES

- A. Materials shall be compatible with insulation materials, jackets, and substrates and for bonding insulation to itself and to surfaces to be insulated, unless otherwise indicated.
- B. Flexible Elastomeric Adhesive: Comply with MIL-A-24179A, Type II, Class I.
- 1. Products: Subject to compliance with requirements, available products that may be incorporated into the Work include, but are not limited to, the following:
 - a. Aeroflex USA, Inc.; Aero seal.
 - b. Armacell LLC; Armaflex 520 Adhesive.
 - c. Foster Brand, Specialty Construction Brands, Inc., a business of H. B. Fuller Company; 85-75.
 - d. K-Flex USA; R-373 Contact Adhesive.
 - 2. For indoor applications, adhesive shall have a VOC content of 50 g/L or less when calculated according to 40 CFR 59, Subpart D (EPA Method 24).
 - 3. Adhesive shall comply with the testing and product requirements of the California Department of Health Services' "Standard Practice for the Testing of Volatile Organic Emissions from Various Sources Using Small-Scale Environmental Chambers."
- C. Mineral-Fiber Adhesive: Comply with MIL-A-3316C, Class 2, Grade A.
- 1. Products: Subject to compliance with requirements, available products that may be incorporated into the Work include, but are not limited to, the following:
 - a. Childers Brand, Specialty Construction Brands, Inc., a business of H. B. Fuller Company; CP-127.
 - b. Eagle Bridges - Marathon Industries; 225.
 - c. Foster Brand, Specialty Construction Brands, Inc., a business of H. B. Fuller Company; 85-60/85-70.
 - d. Mon-Eco Industries, Inc.; 22-25.
 - 2. For indoor applications, adhesive shall have a VOC content of 80 g/L or less when calculated according to 40 CFR 59, Subpart D (EPA Method 24).
 - 3. Adhesive shall comply with the testing and product requirements of the California Department of Health Services' "Standard Practice for the Testing of Volatile Organic Emissions from Various Sources Using Small-Scale Environmental Chambers."
- D. PVC Jacket Adhesive: Compatible with PVC jacket.
- 1. Products: Subject to compliance with requirements, available products that may be incorporated into the Work include, but are not limited to, the following:
 - a. Dow Corning Corporation; 739, Dow Silicone.
 - b. Johns Manville; Zeston Perma-Weld, CEEL-TITE Solvent Welding Adhesive.

Weedsport Addition to Maintenance Section and Roof Replacement, MP 304.2

- c. P.I.C. Plastics, Inc.; Welding Adhesive.
- d. Speedline Corporation; Polyco VP Adhesive.
- 2. For indoor applications, adhesive shall have a VOC content of 50 g/L or less when calculated according to 40 CFR 59, Subpart D (EPA Method 24).
- 3. Adhesive shall comply with the testing and product requirements of the California Department of Health Services' "Standard Practice for the Testing of Volatile Organic Emissions from Various Sources Using Small-Scale Environmental Chambers."

2.4 SEALANTS**A. Joint Sealants:**

- 1. Joint Sealants for Cellular-Glass Products: Subject to compliance with requirements, available products that may be incorporated into the Work include, but are not limited to, the following:
 - a. Childers Brand, Specialty Construction Brands, Inc., a business of H. B. Fuller Company; CP-76.
 - b. Eagle Bridges - Marathon Industries; 405.
 - c. Foster Brand, Specialty Construction Brands, Inc., a business of H. B. Fuller Company; 30-45.
 - d. Mon-Eco Industries, Inc.; 44-05.
 - e. Pittsburgh Corning Corporation; Pittseal 444.
- 2. Materials shall be compatible with insulation materials, jackets, and substrates.
- 3. Permanently flexible, elastomeric sealant.
- 4. Service Temperature Range: Minus 100 to plus 300 deg F.
- 5. Color: White or gray.
- 6. For indoor applications, sealants shall have a VOC content of 420 g/L or less when calculated according to 40 CFR 59, Subpart D (EPA Method 24).
- 7. Sealants shall comply with the testing and product requirements of the California Department of Health Services' "Standard Practice for the Testing of Volatile Organic Emissions from Various Sources Using Small-Scale Environmental Chambers."

2.5 FACTORY-APPLIED JACKETS

- A. Insulation system schedules indicate factory-applied jackets on various applications. When factory-applied jackets are indicated, comply with the following:
 - 1. ASJ: White, kraft-paper, fiberglass-reinforced scrim with aluminum-foil backing; complying with ASTM C 1136, Type I.

2.6 FIELD-APPLIED JACKETS

- A. Field-applied jackets shall comply with ASTM C 921, Type I, unless otherwise indicated.
- B. PVC Jacket: High-impact-resistant, UV-resistant PVC complying with ASTM D 1784, Class 16354-C; thickness as scheduled; roll stock ready for shop or field cutting and forming. Thickness is indicated in field-applied jacket schedules.
 - 1. Products: Subject to compliance with requirements, available products that may be incorporated into the Work include, but are not limited to, the following:
 - a. Johns Manville; Zeston.
 - b. P.I.C. Plastics, Inc.; FG Series.
 - c. Proto Corporation; LoSmoke.
 - d. Speedline Corporation; SmokeSafe.
 - 2. Adhesive: As recommended by jacket material manufacturer.

Weedsport Addition to Maintenance Section and Roof Replacement, MP 304.2

3. Color: White.
4. Factory-fabricated fitting covers to match jacket if available; otherwise, field fabricate.
 - a. Shapes: 45- and 90-degree, short- and long-radius elbows, tees, valves, flanges, unions, reducers, end caps, soil-pipe hubs, traps, mechanical joints, and P-trap and supply covers for lavatories.

2.7 PROTECTIVE SHIELDING GUARDS

- A. Protective Shielding Pipe Covers at ADA Lavatories :
 1. Manufacturers: Subject to compliance with requirements, available manufacturers offering products that may be incorporated into the Work include, but are not limited to, the following:
 - a. Engineered Brass Company.
 - b. Insul-Tect Products Co.; a subsidiary of MVG Molded Products.
 - c. McGuire Manufacturing.
 - d. Plumberex.
 - e. Truebro; a brand of IPS Corporation.
 - f. Zurn Industries, LLC; Tubular Brass Plumbing Products Operation.
 2. Description: Manufactured plastic wraps for covering plumbing fixture hot- and cold-water supplies and trap and drain piping. Comply with Americans with Disabilities Act (ADA) requirements.

PART 3 - EXECUTION**3.1 EXAMINATION**

- A. Examine substrates and conditions for compliance with requirements for installation tolerances and other conditions affecting performance of insulation application.
 1. Verify that systems to be insulated have been tested and are free of defects.
 2. Verify that surfaces to be insulated are clean and dry.
- B. Proceed with installation only after unsatisfactory conditions have been corrected.

3.2 PREPARATION

- A. Surface Preparation: Clean and dry surfaces to receive insulation. Remove materials that will adversely affect insulation application.

3.3 GENERAL INSTALLATION REQUIREMENTS

- A. Install insulation materials, accessories, and finishes with smooth, straight, and even surfaces; free of voids throughout the length of piping including fittings, valves, and specialties.
- B. Install accessories compatible with insulation materials and suitable for the service. Install accessories that do not corrode, soften, or otherwise attack insulation or jacket in either wet or dry state.
- C. Install insulation with longitudinal seams at top and bottom of horizontal runs.
- D. Install multiple layers of insulation with longitudinal and end seams staggered.
- E. Do not weld brackets, clips, or other attachment devices to piping, fittings, and specialties.
- F. Keep insulation materials dry during application and finishing.

Weedspport Addition to Maintenance Section and Roof Replacement, MP 304.2

- G. Install insulation with tight longitudinal seams and end joints. Bond seams and joints with adhesive recommended by insulation material manufacturer.
- H. Install insulation with least number of joints practical.
- I. Where vapor barrier is indicated, seal joints, seams, and penetrations in insulation at hangers, supports, anchors, and other projections with vapor-barrier mastic.
 - 1. Install insulation continuously through hangers and around anchor attachments.
 - 2. For insulation application where vapor barriers are indicated, extend insulation on anchor legs from point of attachment to supported item to point of attachment to structure. Taper and seal ends at attachment to structure with vapor-barrier mastic.
 - 3. Install insert materials and install insulation to tightly join the insert. Seal insulation to insulation inserts with adhesive or sealing compound recommended by insulation material manufacturer.
 - 4. Cover inserts with jacket material matching adjacent pipe insulation. Install shields over jacket, arranged to protect jacket from tear or puncture by hanger, support, and shield.
- J. Apply adhesives, mastics, and sealants at manufacturer's recommended coverage rate and wet and dry film thicknesses.
- K. Install insulation with factory-applied jackets as follows:
 - 1. Draw jacket tight and smooth.
 - 2. Cover circumferential joints with 3-inch- wide strips, of same material as insulation jacket. Secure strips with adhesive and outward clinching staples along both edges of strip, spaced 4 inches o.c.
 - 3. Overlap jacket longitudinal seams at least 1-1/2 inches. Install insulation with longitudinal seams at bottom of pipe. Clean and dry surface to receive self-sealing lap. Staple laps with outward clinching staples along edge at 2 inches o.c.
 - a. For below-ambient services, apply vapor-barrier mastic over staples.
 - 4. Cover joints and seams with tape, according to insulation material manufacturer's written instructions, to maintain vapor seal.
 - 5. Where vapor barriers are indicated, apply vapor-barrier mastic on seams and joints and at ends adjacent to pipe flanges and fittings.
- L. Cut insulation in a manner to avoid compressing insulation more than 75 percent of its nominal thickness.
- M. Finish installation with systems at operating conditions. Repair joint separations and cracking due to thermal movement.
- N. Repair damaged insulation facings by applying same facing material over damaged areas. Extend patches at least 4 inches beyond damaged areas. Adhere, staple, and seal patches similar to butt joints.
- O. For above-ambient services, do not install insulation to the following:
 - 1. Vibration-control devices.
 - 2. Testing agency labels and stamps.
 - 3. Nameplates and data plates.
 - 4. Cleanouts.

3.4 PENETRATIONS

- A. Insulation Installation at Roof Penetrations: Install insulation continuously through roof penetrations.
 - 1. Seal penetrations with flashing sealant.

Weedsport Addition to Maintenance Section and Roof Replacement, MP 304.2

2. For applications requiring only indoor insulation, terminate insulation above roof surface and seal with joint sealant. For applications requiring indoor and outdoor insulation, install insulation for outdoor applications tightly joined to indoor insulation ends. Seal joint with joint sealant.
 3. Extend jacket of outdoor insulation outside roof flashing at least 2 inches below top of roof flashing.
 4. Seal jacket to roof flashing with flashing sealant.
- B. Insulation Installation at Underground Exterior Wall Penetrations: Terminate insulation flush with sleeve seal. Seal terminations with flashing sealant.
- C. Insulation Installation at Interior Wall and Partition Penetrations (That Are Not Fire Rated): Install insulation continuously through walls and partitions.

3.5 GENERAL PIPE INSULATION INSTALLATION

- A. Requirements in this article generally apply to all insulation materials except where more specific requirements are specified in various pipe insulation material installation articles.
- B. Insulation Installation on Fittings, Valves, Strainers, Flanges, and Unions:
1. Install insulation over fittings, valves, strainers, flanges, unions, and other specialties with continuous thermal and vapor-retarder integrity unless otherwise indicated.
 2. Insulate pipe elbows using preformed fitting insulation or mitered fittings made from same material and density as adjacent pipe insulation. Each piece shall be butted tightly against adjoining piece and bonded with adhesive. Fill joints, seams, voids, and irregular surfaces with insulating cement finished to a smooth, hard, and uniform contour that is uniform with adjoining pipe insulation.
 3. Insulate tee fittings with preformed fitting insulation or sectional pipe insulation of same material and thickness as used for adjacent pipe. Cut sectional pipe insulation to fit. Butt each section closely to the next and hold in place with tie wire. Bond pieces with adhesive.
 4. Insulate valves using preformed fitting insulation or sectional pipe insulation of same material, density, and thickness as used for adjacent pipe. Overlap adjoining pipe insulation by not less than two times the thickness of pipe insulation, or one pipe diameter, whichever is thicker. For valves, insulate up to and including the bonnets, valve stuffing-box studs, bolts, and nuts. Fill joints, seams, and irregular surfaces with insulating cement.
 5. Insulate flanges and unions using a section of oversized preformed pipe insulation. Overlap adjoining pipe insulation by not less than two times the thickness of pipe insulation, or one pipe diameter, whichever is thicker.
 6. Cover segmented insulated surfaces with a layer of finishing cement and coat with a mastic. Install vapor-barrier mastic for below-ambient services and a breather mastic for above-ambient services. Reinforce the mastic with fabric-reinforcing mesh. Trowel the mastic to a smooth and well-shaped contour.
 7. For services not specified to receive a field-applied jacket except for flexible elastomeric and polyolefin, install fitted PVC cover over elbows, tees, strainers, valves, flanges, and unions. Terminate ends with PVC end caps. Tape PVC covers to adjoining insulation facing using PVC tape.
 8. Stencil or label the outside insulation jacket of each union with the word "union." Match size and color of pipe labels.
- C. Insulate instrument connections for thermometers, pressure gages, pressure temperature taps, test connections, flow meters, sensors, switches, and transmitters on insulated pipes. Shape insulation

Weedsport Addition to Maintenance Section and Roof Replacement, MP 304.2

at these connections by tapering it to and around the connection with insulating cement and finish with finishing cement, mastic, and flashing sealant.

3.6 INSTALLATION OF FLEXIBLE ELASTOMERIC INSULATION

- A. Seal longitudinal seams and end joints with manufacturer's recommended adhesive to eliminate openings in insulation that allow passage of air to surface being insulated.
- B. Insulation Installation on Pipe Flanges:
 - 1. Install pipe insulation to outer diameter of pipe flange.
 - 2. Make width of insulation section same as overall width of flange and bolts, plus twice the thickness of pipe insulation.
 - 3. Fill voids between inner circumference of flange insulation and outer circumference of adjacent straight pipe segments with cut sections of sheet insulation of same thickness as pipe insulation.
 - 4. Secure insulation to flanges and seal seams with manufacturer's recommended adhesive to eliminate openings in insulation that allow passage of air to surface being insulated.
- C. Insulation Installation on Pipe Fittings and Elbows:
 - 1. Install mitered sections of pipe insulation.
 - 2. Secure insulation materials and seal seams with manufacturer's recommended adhesive to eliminate openings in insulation that allow passage of air to surface being insulated.
- D. Insulation Installation on Valves and Pipe Specialties:
 - 1. Install preformed valve covers manufactured of same material as pipe insulation when available.
 - 2. When preformed valve covers are not available, install cut sections of pipe and sheet insulation to valve body. Arrange insulation to permit access to packing and to allow valve operation without disturbing insulation.
 - 3. Install insulation to flanges as specified for flange insulation application.
 - 4. Secure insulation to valves and specialties and seal seams with manufacturer's recommended adhesive to eliminate openings in insulation that allow passage of air to surface being insulated.

3.7 INSTALLATION OF MINERAL-FIBER INSULATION

- A. Insulation Installation on Straight Pipes and Tubes:
 - 1. Secure each layer of preformed pipe insulation to pipe with wire or bands and tighten bands without deforming insulation materials.
 - 2. Where vapor barriers are indicated, seal longitudinal seams, end joints, and protrusions with vapor-barrier mastic and joint sealant.
 - 3. For insulation with factory-applied jackets on above-ambient surfaces, secure laps with outward clinched staples at 6 inches o.c.
 - 4. For insulation with factory-applied jackets on below-ambient surfaces, do not staple longitudinal tabs. Instead, secure tabs with additional adhesive as recommended by insulation material manufacturer and seal with vapor-barrier mastic and flashing sealant.
- B. Insulation Installation on Pipe Flanges:
 - 1. Install preformed pipe insulation to outer diameter of pipe flange.
 - 2. Make width of insulation section same as overall width of flange and bolts, plus twice the thickness of pipe insulation.
 - 3. Fill voids between inner circumference of flange insulation and outer circumference of adjacent straight pipe segments with mineral-fiber blanket insulation.

Weedsport Addition to Maintenance Section and Roof Replacement, MP 304.2

4. Install jacket material with manufacturer's recommended adhesive, overlap seams at least 1 inch, and seal joints with flashing sealant.
- C. Insulation Installation on Pipe Fittings and Elbows:
1. Install preformed sections of same material as straight segments of pipe insulation when available.
 2. When preformed insulation elbows and fittings are not available, install mitered sections of pipe insulation, to a thickness equal to adjoining pipe insulation. Secure insulation materials with wire or bands.
- D. Insulation Installation on Valves and Pipe Specialties:
1. Install preformed sections of same material as straight segments of pipe insulation when available.
 2. When preformed sections are not available, install mitered sections of pipe insulation to valve body.
 3. Arrange insulation to permit access to packing and to allow valve operation without disturbing insulation.
 4. Install insulation to flanges as specified for flange insulation application.

3.8 FIELD-APPLIED JACKET INSTALLATION

- A. Where PVC jackets are indicated, install with 1-inch overlap at longitudinal seams and end joints. Seal with manufacturer's recommended adhesive.
1. Apply two continuous beads of adhesive to seams and joints, one bead under lap and the finish bead along seam and joint edge.

3.9 FIELD QUALITY CONTROL

- A. Testing Agency: Engage a qualified testing agency to perform tests and inspections.
- B. Perform tests and inspections.
- C. Tests and Inspections:
1. Inspect pipe, fittings, strainers, and valves, randomly selected by Architect, by removing field-applied jacket and insulation in layers in reverse order of their installation. Extent of inspection shall be limited to three locations of straight pipe, three locations of threaded fittings, locations of threaded valves, and locations of flanged valves for each pipe service defined in the "Piping Insulation Schedule, General" Article.
- D. All insulation applications will be considered defective Work if sample inspection reveals noncompliance with requirements.

3.10 PIPING INSULATION SCHEDULE, GENERAL

- A. Acceptable preformed pipe and tubular insulation materials and thicknesses are identified for each piping system and pipe size range. If more than one material is listed for a piping system, selection from materials listed is Contractor's option.
- B. Items Not Insulated: Unless otherwise indicated, do not install insulation on the following:
1. Drainage piping located in crawl spaces.
 2. Underground piping.
 3. Chrome-plated pipes and fittings unless there is a potential for personnel injury.

3.11 INDOOR PIPING INSULATION SCHEDULE

- A. Domestic Cold Water:

Weedsport Addition to Maintenance Section and Roof Replacement, MP 304.2

1. NPS 1 and Smaller: Insulation shall be one of the following:
 - a. Flexible Elastomeric: 1 inch Insert dimension thick.
 - b. Mineral-Fiber, Preformed Pipe Insulation, Type I: 1/2 inch thick.
 2. NPS 1-1/4 and Larger: Insulation shall be one of the following:
 - a. Flexible Elastomeric: 1 inch thick.
 - b. Mineral-Fiber, Preformed Pipe Insulation, Type I: 1 inch thick.
- B. Domestic Hot and Recirculated Hot Water (105-140 F):
1. NPS 1-1/4 and Smaller: Insulation shall be one of the following:
 - a. Flexible Elastomeric: 1 inch thick.
 - b. Mineral-Fiber, Preformed Pipe Insulation, Type I: 1-1/2 inch thick.
 2. NPS 1-1/2 and Larger: Insulation shall be one of the following:
 - a. Flexible Elastomeric: 1 inch thick.
 - b. Mineral-Fiber, Preformed Pipe Insulation, Type I: 1-1/2 inch thick.
- C. Stormwater and Overflow:
1. All Pipe Sizes: Insulation shall be one of the following:
 - a. Flexible Elastomeric: 1 inch thick.
 - b. Mineral-Fiber, Preformed Pipe Insulation, Type I: 1 inch thick.
- D. Roof Drain and Overflow Drain Bodies:
1. All Pipe Sizes: Insulation shall be one of the following:
 - a. Flexible Elastomeric: 1 inch thick.
 - b. Mineral-Fiber, Preformed Pipe Insulation, Type I: 1 inch thick.
- E. Exposed Sanitary Drains, Domestic Water, Domestic Hot Water, and Stops for Plumbing Fixtures for People with Disabilities:
1. All Pipe Sizes: Insulation shall be the following:
 - a. Mineral-Fiber, Preformed Pipe Insulation, Type I: 1/2 inch thick.
- F. Sanitary Waste Piping Where Heat Tracing Is Installed:
1. All Pipe Sizes: Insulation shall be the following:
 - a. Cellular Glass: 2 inches thick.

3.12 INDOOR, FIELD-APPLIED JACKET SCHEDULE

- A. Install jacket over insulation material. For insulation with factory-applied jacket, install the field-applied jacket over the factory-applied jacket.
- B. If more than one material is listed, selection from materials listed is Contractor's option.
- C. Piping, Concealed:
 1. None.
- D. Piping, Exposed:
 1. PVC: 20 mils thick.

END OF SECTION 220719

SECTION 221116 - DOMESTIC WATER PIPING

PART 1 - GENERAL

1.1 RELATED DOCUMENTS

- A. Drawings and general provisions of the Contract, including General and Supplementary Conditions and Division 01 Specification Sections, apply to this Section.

1.2 SUMMARY

- A. Section Includes:
 - 1. Under-building-slab and aboveground domestic water pipes, tubes, and fittings inside buildings.
 - 2. Encasement for piping.

1.3 ACTION SUBMITTALS

- A. Product Data: For transition fittings and dielectric fittings.

1.4 INFORMATIONAL SUBMITTALS

- A. System purging and disinfecting activities report.
- B. Field quality-control reports.

1.5 QUALITY ASSURANCE

- A. Regulatory Requirements:
 - 1. Comply with requirements of utility company supplying water. Include tapping of water mains and backflow prevention.
 - 2. Comply with standards of authorities having jurisdiction for potable-water-service piping, including materials, installation, testing, and disinfection.
- B. Piping materials shall bear label, stamp, or other markings of specified testing agency.
- C. Per new Federal Lead-Free Law, any product designed for dispensing potable water meet both the NSF 61 and NSF 372 test standards via third-party testing and certification.

1.6 FIELD CONDITIONS

- A. Interruption of Existing Water Service: Do not interrupt water service to facilities occupied by Owner or others unless permitted under the following conditions and then only after arranging to provide temporary water service according to requirements indicated:
 - 1. Notify Architect, Construction Manager and Owner no fewer than two days in advance of proposed interruption of water service.
 - 2. Do not interrupt water service without Owner's written permission.

PART 2 - PRODUCTS

2.1 PIPING MATERIALS

- A. Comply with requirements in "Piping Schedule" Article for applications of pipe, tube, fitting materials, and joining methods for specific services, service locations, and pipe sizes.

Weedsport Addition to Maintenance Section and Roof Replacement, MP 304.2

- B. Potable-water piping and components shall comply with NSF 14 and NSF 61. Plastic piping components shall be marked with "NSF-pw."

2.2 COPPER TUBE AND FITTINGS

- A. Hard Copper Tube: ASTM B 88, Type L water tube, drawn temper.
- B. Soft Copper Tube: ASTM B 88, Type L water tube, annealed temper.
- C. Cast-Copper, Solder-Joint Fittings: ASME B16.18, pressure fittings.
- D. Wrought-Copper, Solder-Joint Fittings: ASME B16.22, wrought-copper pressure fittings.
- E. Bronze Flanges: ASME B16.24, Class 150, with solder-joint ends.
- F. Copper Unions:
 - 1. MSS SP-123.
 - 2. Cast-copper-alloy, hexagonal-stock body.
 - 3. Ball-and-socket, metal-to-metal seating surfaces.
 - 4. Solder-joint or threaded ends.

2.3 DUCTILE-IRON PIPE AND FITTINGS

- A. Mechanical-Joint, Ductile-Iron Pipe:
 - 1. AWWA C151/A21.51, with mechanical-joint bell and plain spigot end unless grooved or flanged ends are indicated.
 - 2. Glands, Gaskets, and Bolts: AWWA C111/A21.11, ductile- or gray-iron glands, rubber gaskets, and steel bolts.
- B. Standard-Pattern, Mechanical-Joint Fittings:
 - 1. AWWA C110/A21.10, ductile or gray iron.
 - 2. Glands, Gaskets, and Bolts: AWWA C111/A21.11, ductile- or gray-iron glands, rubber gaskets, and steel bolts.
- C. Standard-Pattern, Push-on-Joint Fittings:
 - 1. AWWA C110/A21.10, ductile or gray iron.
 - 2. Gaskets: AWWA C111/A21.11, rubber.
- D. Plain-End, Ductile-Iron Pipe: AWWA C151/A21.51.

2.4 PIPING JOINING MATERIALS

- A. Pipe-Flange Gasket Materials:
 - 1. AWWA C110/A21.10, rubber, flat face, 1/8 inch thick or ASME B16.21, nonmetallic and asbestos free unless otherwise indicated.
 - 2. Full-face or ring type unless otherwise indicated.
- B. Metal, Pipe-Flange Bolts and Nuts: ASME B18.2.1, carbon steel unless otherwise indicated.
- C. Solder Filler Metals: ASTM B 32, lead-free alloys.
- D. Flux: ASTM B 813, water flushable.

2.5 TRANSITION FITTINGS

- A. General Requirements:
 - 1. Same size as pipes to be joined.
 - 2. Pressure rating at least equal to pipes to be joined.

Weedsport Addition to Maintenance Section and Roof Replacement, MP 304.2

3. End connections compatible with pipes to be joined.
- B. Fitting-Type Transition Couplings: Manufactured piping coupling or specified piping system fitting.
- C. Sleeve-Type Transition Coupling: AWWA C219.
 1. Manufacturers: Subject to compliance with requirements, available manufacturers offering products that may be incorporated into the Work include, but are not limited to, the following:
 - a. Cascade Waterworks Manufacturing.
 - b. Dresser, Inc.; Piping Specialties Products.
 - c. Ford Meter Box Company, Inc. (The).
 - d. JCM Industries.
 - e. Romac Industries, Inc.
 - f. Smith-Blair, Inc.; a Sensus company.
 - g. Viking Johnson.

2.6 DIELECTRIC FITTINGS

- A. General Requirements: Assembly of copper alloy and ferrous materials with separating nonconductive insulating material. Include end connections compatible with pipes to be joined.
- B. Dielectric Unions:
 1. Manufacturers: Subject to compliance with requirements, available manufacturers offering products that may be incorporated into the Work include, but are not limited to, the following:
 - a. Capitol Manufacturing Company; member of the Phoenix Forge Group.
 - b. Central Plastics Company.
 - c. Hart Industries International, Inc.
 - d. Jomar International.
 - e. Matco-Norca.
 - f. McDonald, A. Y. Mfg. Co.
 - g. Watts; a division of Watts Water Technologies, Inc.
 - h. Wilkins; a Zurn company.
 2. Standard: ASSE 1079.
 3. Pressure Rating: 150 psig minimum at 180 deg F.
 4. End Connections: Solder-joint copper alloy and threaded ferrous.
- C. Dielectric Flanges:
 1. Manufacturers: Subject to compliance with requirements, available manufacturers offering products that may be incorporated into the Work include, but are not limited to, the following:
 - a. Capitol Manufacturing Company; member of the Phoenix Forge Group.
 - b. Central Plastics Company.
 - c. Matco-Norca.
 - d. Watts; a division of Watts Water Technologies, Inc.
 - e. Wilkins; a Zurn company.
 2. Standard: ASSE 1079.
 3. Factory-fabricated, bolted, companion-flange assembly.
 4. Pressure Rating: 150 psig minimum at 180 deg F.
 5. End Connections: Solder-joint copper alloy and threaded ferrous; threaded solder-joint copper alloy and threaded ferrous.
- D. Dielectric-Flange Insulating Kits:

Weedsport Addition to Maintenance Section and Roof Replacement, MP 304.2

1. Manufacturers: Subject to compliance with requirements, available manufacturers offering products that may be incorporated into the Work include, but are not limited to, the following:
 - a. Advance Products & Systems, Inc.
 - b. Calpico, Inc.
 - c. Central Plastics Company.
 - d. Pipeline Seal and Insulator, Inc.
 2. Nonconducting materials for field assembly of companion flanges.
 3. Pressure Rating: 150 psig.
 4. Gasket: Neoprene or phenolic.
 5. Bolt Sleeves: Phenolic or polyethylene.
 6. Washers: Phenolic with steel backing washers.
- E. Dielectric Nipples:
1. Manufacturers: Subject to compliance with requirements, available manufacturers offering products that may be incorporated into the Work include, but are not limited to, the following:
 - a. Elster Perfection Corporation.
 - b. Grinnell Mechanical Products; Tyco Fire Products LP.
 - c. Matco-Norca.
 - d. Precision Plumbing Products, Inc.
 - e. Victaulic Company.
 2. Standard: IAPMO PS 66.
 3. Electroplated steel nipple complying with ASTM F 1545.
 4. Pressure Rating and Temperature: 300 psig at 225 deg F.
 5. End Connections: Male threaded or grooved.
 6. Lining: Inert and noncorrosive, propylene.

PART 3 - EXECUTION

3.1 EARTHWORK

- A. Comply with requirements in Section 312000 "Earth Moving" for excavating, trenching, and backfilling.

3.2 PIPING INSTALLATION

- A. Drawing plans, schematics, and diagrams indicate general location and arrangement of domestic water piping. Indicated locations and arrangements are used to size pipe and calculate friction loss, expansion, and other design considerations. Install piping as indicated unless deviations to layout are approved on coordination drawings.
- B. Install copper tubing under building slab according to CDA's "Copper Tube Handbook."
- C. Install ductile-iron piping under building slab with restrained joints according to AWWA C600 and AWWA M41.
- D. Install underground ductile-iron pipe in PE encasement according to ASTM A 674 or AWWA C105/A21.5.
- E. Install shutoff valve, hose-end drain valve, strainer, pressure gage, and test tee with valve inside the building at each domestic water-service entrance. Comply with requirements for pressure gages in Section 220519 "Meters and Gages for Plumbing Piping" and with requirements for drain valves and strainers in Section 221119 "Domestic Water Piping Specialties."

Weedsport Addition to Maintenance Section and Roof Replacement, MP 304.2

- F. Install shutoff valve immediately upstream of each dielectric fitting.
- G. Install water-pressure-reducing valves downstream from shutoff valves. Comply with requirements for pressure-reducing valves in Section 221119 "Domestic Water Piping Specialties."
- H. Install domestic water piping level without pitch and plumb.
- I. Rough-in domestic water piping for water-meter installation according to utility company's requirements.
- J. Install seismic restraints on piping. Comply with requirements for seismic-restraint devices in Division 22 "Vibration and Seismic Controls for Plumbing Piping and Equipment."
- K. Install piping concealed from view and protected from physical contact by building occupants unless otherwise indicated and except in equipment rooms and service areas.
- L. Install piping indicated to be exposed and piping in equipment rooms and service areas at right angles or parallel to building walls. Diagonal runs are prohibited unless specifically indicated otherwise.
- M. Install piping above accessible ceilings to allow sufficient space for ceiling panel removal, and coordinate with other services occupying that space.
- N. Install piping to permit valve servicing.
- O. Install nipples, unions, special fittings, and valves with pressure ratings the same as or higher than the system pressure rating used in applications below unless otherwise indicated.
- P. Install piping free of sags and bends.
- Q. Install fittings for changes in direction and branch connections.
- R. Install unions in copper tubing at final connection to each piece of equipment, machine, and specialty.
- S. Install pressure gages on suction and discharge piping for each plumbing pump and packaged booster pump. Comply with requirements for pressure gages in Division 22 "Meters and Gages for Plumbing Piping."
- T. Install thermostats in hot-water circulation piping near water heater.
- U. Install thermometers on inlet and outlet piping from each water heater. Comply with requirements for thermometers in Section 220519 "Meters and Gages for Plumbing Piping."
- V. Install sleeves for piping penetrations of walls, ceilings, and floors. Comply with requirements for sleeves specified in Section 220517 "Sleeves and Sleeve Seals for Plumbing Piping."
- W. Install sleeve seals for piping penetrations of concrete walls and slabs. Comply with requirements for sleeve seals specified in Section 220517 "Sleeves and Sleeve Seals for Plumbing Piping."
- X. Install escutcheons for piping penetrations of walls, ceilings, and floors. Comply with requirements for escutcheons specified in Section 220518 "Escutcheons for Plumbing Piping."

3.3 JOINT CONSTRUCTION

- A. Ream ends of pipes and tubes and remove burrs. Bevel plain ends of steel pipe.
- B. Remove scale, slag, dirt, and debris from inside and outside of pipes, tubes, and fittings before assembly.

Weedsport Addition to Maintenance Section and Roof Replacement, MP 304.2

- C. Threaded Joints: Thread pipe with tapered pipe threads according to ASME B1.20.1. Cut threads full and clean using sharp dies. Ream threaded pipe ends to remove burrs and restore full ID. Join pipe fittings and valves as follows:
 - 1. Apply appropriate tape or thread compound to external pipe threads.
 - 2. Damaged Threads: Do not use pipe or pipe fittings with threads that are corroded or damaged.
- D. Soldered Joints for Copper Tubing: Apply ASTM B 813, water-flushable flux to end of tube. Join copper tube and fittings according to ASTM B 828 or CDA's "Copper Tube Handbook."
- E. Joint Construction for Grooved-End, Ductile-Iron Piping: Make joints according to AWWA C606. Cut round-bottom grooves in ends of pipe at gasket-seat dimension required for specified (flexible or rigid) joint. Lubricate and install gasket over ends of pipes or pipe and fitting. Install coupling housing sections over gasket with keys seated in piping grooves. Install and tighten housing bolts.
- F. Flanged Joints: Select appropriate asbestos-free, nonmetallic gasket material in size, type, and thickness suitable for domestic water service. Join flanges with gasket and bolts according to ASME B31.9.
- G. Joints for Dissimilar-Material Piping: Make joints using adapters compatible with materials of both piping systems.

3.4 TRANSITION FITTING INSTALLATION

- A. Install transition couplings at joints of dissimilar piping.
- B. Transition Fittings in Underground Domestic Water Piping:
 - 1. Fittings for NPS 1-1/2 and Smaller: Fitting-type coupling.
 - 2. Fittings for NPS 2 and Larger: Sleeve-type coupling.

3.5 DIELECTRIC FITTING INSTALLATION

- A. Install dielectric fittings in piping at connections of dissimilar metal piping and tubing.
- B. Dielectric Fittings for NPS 2 and Smaller: Use dielectric couplings or nipples.
- C. Dielectric Fittings for NPS 2-1/2 to NPS 4: Use dielectric flange kits.
- D. Dielectric Fittings for NPS 5 and Larger: Use dielectric flange kits.

3.6 HANGER AND SUPPORT INSTALLATION

- A. Comply with requirements for pipe hanger, support products, and installation in Section 220529 "Hangers and Supports for Plumbing Piping and Equipment."
 - 1. Vertical Piping: MSS Type 8 or 42, clamps.
 - 2. Individual, Straight, Horizontal Piping Runs:
 - a. 100 Feet and Less: MSS Type 1, adjustable, steel clevis hangers.
 - b. Longer Than 100 Feet: MSS Type 43, adjustable roller hangers.
 - c. Longer Than 100 Feet if Indicated: MSS Type 49, spring cushion rolls.
 - 3. Multiple, Straight, Horizontal Piping Runs 100 Feet or Longer: MSS Type 44, pipe rolls. Support pipe rolls on trapeze.
 - 4. Base of Vertical Piping: MSS Type 52, spring hangers.
- B. Support vertical piping and tubing at base and at each floor.
- C. Rod diameter may be reduced one size for double-rod hangers, to a minimum of 3/8 inch.

Weedsport Addition to Maintenance Section and Roof Replacement, MP 304.2

- D. Install hangers for copper tubing with the following maximum horizontal spacing and minimum rod diameters:
 1. NPS 3/4 and Smaller: 60 inches with 3/8-inch rod.
 2. NPS 1 and NPS 1-1/4: 72 inches with 3/8-inch rod.
 3. NPS 1-1/2 and NPS 2: 96 inches with 3/8-inch rod.
 4. NPS 2-1/2: 108 inches with 1/2-inch rod.
 5. NPS 3 to NPS 5: 10 feet with 1/2-inch rod.
 6. NPS 6: 10 feet with 5/8-inch rod.
- E. Install supports for vertical copper tubing every 10 feet.
- F. Support piping and tubing not listed in this article according to MSS SP-69 and manufacturer's written instructions.

3.7 CONNECTIONS

- A. Drawings indicate general arrangement of piping, fittings, and specialties.
- B. When installing piping adjacent to equipment and machines, allow space for service and maintenance.
- C. Connect domestic water piping to exterior water-service piping. Use transition fitting to join dissimilar piping materials.
- D. Connect domestic water piping to water-service piping with shutoff valve; extend and connect to the following:
 1. Water Heaters: Cold-water inlet and hot-water outlet piping in sizes indicated, but not smaller than sizes of water heater connections.
 2. Plumbing Fixtures: Cold- and hot-water-supply piping in sizes indicated, but not smaller than that required by plumbing code.
 3. Equipment: Cold- and hot-water-supply piping as indicated, but not smaller than equipment connections. Provide shutoff valve and union for each connection. Use flanges instead of unions for NPS 2-1/2 and larger.

3.8 IDENTIFICATION

- A. Identify system components.
- B. Label pressure piping with system operating pressure.

3.9 FIELD QUALITY CONTROL

- A. Perform the following tests and inspections:
 1. Piping Inspections:
 - a. Do not enclose, cover, or put piping into operation until it has been inspected and approved by authorities having jurisdiction.
 - b. During installation, notify authorities having jurisdiction at least one day before inspection must be made. Perform tests specified below in presence of authorities having jurisdiction:
 - 1) Roughing-in Inspection: Arrange for inspection of piping before concealing or closing in after roughing in and before setting fixtures.
 - 2) Final Inspection: Arrange for authorities having jurisdiction to observe tests specified in "Piping Tests" Subparagraph below and to ensure compliance with requirements.

Weedsport Addition to Maintenance Section and Roof Replacement, MP 304.2

- c. Reinspection: If authorities having jurisdiction find that piping will not pass tests or inspections, make required corrections and arrange for reinspection.
 - d. Reports: Prepare inspection reports and have them signed by authorities having jurisdiction.
2. Piping Tests:
- a. Fill domestic water piping. Check components to determine that they are not air bound and that piping is full of water.
 - b. Test for leaks and defects in new piping and parts of existing piping that have been altered, extended, or repaired. If testing is performed in segments, submit a separate report for each test, complete with diagram of portion of piping tested.
 - c. Leave new, altered, extended, or replaced domestic water piping uncovered and unconcealed until it has been tested and approved. Expose work that was covered or concealed before it was tested.
 - d. Cap and subject piping to static water pressure of 50 psig above operating pressure, without exceeding pressure rating of piping system materials. Isolate test source and allow it to stand for two hours. Leaks and loss in test pressure constitute defects that must be repaired.
 - e. Repair leaks and defects with new materials, and retest piping or portion thereof until satisfactory results are obtained.
 - f. Prepare reports for tests and for corrective action required.
- B. Domestic water piping will be considered defective if it does not pass tests and inspections.
- C. Reports: Prepare inspection and test reports and have them signed by authorities having jurisdiction. Submit all reports to Architect.

3.10 ADJUSTING

- A. Perform the following adjustments before operation:
- 1. Close drain valves, hydrants, and hose bibbs.
 - 2. Open shutoff valves to fully open position.
 - 3. Open throttling valves to proper setting.
 - 4. Adjust balancing valves in hot-water-circulation return piping to provide adequate flow.
 - a. Manually adjust ball-type balancing valves in hot-water-circulation return piping to provide hot-water flow in each branch.
 - b. Adjust calibrated balancing valves to flows indicated.
 - 5. Remove plugs used during testing of piping and for temporary sealing of piping during installation.
 - 6. Remove and clean strainer screens. Close drain valves and replace drain plugs.
 - 7. Remove filter cartridges from housings and verify that cartridges are as specified for application were used and are clean and ready for use.
 - 8. Check plumbing specialties and verify proper settings, adjustments, and operation.

3.11 CLEANING

- A. Clean and disinfect potable domestic water piping as follows:
- 1. Purge new piping and parts of existing piping that have been altered, extended, or repaired before using.
 - 2. Use purging and disinfecting procedures prescribed by authorities having jurisdiction; if methods are not prescribed, use procedures described in either AWWA C651 or AWWA C652 or follow procedures described below:
 - a. Flush piping system with clean, potable water until dirty water does not appear at outlets.

Weedsport Addition to Maintenance Section and Roof Replacement, MP 304.2

- b. Fill and isolate system according to either of the following:
 - 1) Fill system or part thereof with water/chlorine solution with at least 50 ppm of chlorine. Isolate with valves and allow to stand for 24 hours. OR
 - 2) Fill system or part thereof with water/chlorine solution with at least 200 ppm of chlorine. Isolate and allow to stand for three hours.
 - c. Flush system with clean, potable water until no chlorine is in water coming from system after the standing time.
 - d. Repeat procedures if biological examination shows contamination.
 - e. Submit water samples in sterile bottles to NYS Department of Health approved lab with results sent to the architect/engineer of record.
- B. Prepare and submit reports of purging and disinfecting activities. Include copies of water-sample approvals from NYS Department of Health approved lab.
 - C. Clean interior of domestic water piping system. Remove dirt and debris as work progresses.

3.12 PIPING SCHEDULE

- A. Transition and special fittings with pressure ratings at least equal to piping rating may be used in applications below unless otherwise indicated.
- B. Flanges and unions may be used for aboveground piping joints unless otherwise indicated.
- C. Fitting Option: Extruded-tee connections and brazed joints may be used on aboveground copper tubing.
- D. Under-building-slab (and above ground stub up to backflow prevention device), combined domestic water, building-service, and fire-service-main piping, NPS 6 to NPS 12, shall be the following:
 - 1. Mechanical-joint, ductile-iron pipe; standard-pattern, mechanical-joint fittings; and mechanical joints.
 - 2. Push-on-joint, ductile-iron pipe; standard-pattern, push-on-joint fittings; and gasketed joints.
- E. Under-building-slab, domestic water piping, NPS 2 and smaller, shall be the following:
 - 1. Soft copper tube, ASTM B 88, Type L; wrought-copper, solder-joint fittings; and brazed joints.
- F. Aboveground domestic water piping, NPS 2 and smaller, shall be the following:
 - 1. Hard copper tube, ASTM B 88, Type L; cast- or wrought-copper, solder-joint fittings; and soldered joints.
- G. Aboveground domestic water piping, NPS 2-1/2 to NPS 6, shall be the following:
 - 1. Hard copper tube, ASTM B 88, Type L; cast- or wrought-copper, solder-joint fittings; and soldered joints.
- H. Aboveground combined domestic water-service and fire-service-main piping (up to backflow prevention device), NPS 6 to NPS 12, shall be one of the following:
 - 1. Plain-end, ductile-iron pipe; grooved-joint, ductile-iron-pipe appurtenances; and grooved joints.
 - 2. Fire Protection service shall not transition to Steel pipe until downstream of the backflow prevention device.

3.13 VALVE SCHEDULE

- A. Drawings indicate valve types to be used. Where specific valve types are not indicated, the following requirements apply:
1. Shutoff Duty: Use ball or gate valves for piping NPS 2 and smaller. Use butterfly, ball, or gate valves with flanged ends for piping NPS 2-1/2 and larger.
 2. Throttling Duty: Use ball or globe valves for piping NPS 2 and smaller. Use butterfly or ball valves with flanged ends for piping NPS 2-1/2 and larger.
 3. Hot-Water Circulation Piping, Balancing Duty: Calibrated balancing valves.
 4. Drain Duty: Hose-end drain valves.
- B. Use check valves to maintain correct direction of domestic water flow to and from equipment.
- C. Iron grooved-end valves may be used with grooved-end piping.

END OF SECTION 221116

SECTION 221119 - DOMESTIC WATER PIPING SPECIALTIES

PART 1 - GENERAL

1.1 RELATED DOCUMENTS

- A. Drawings and general provisions of the Contract, including General and Supplementary Conditions and Division 01 Specification Sections, apply to this Section.

1.2 SUMMARY

- A. Section Includes:
1. Vacuum breakers.
 2. Backflow preventers.
 3. Balancing valves.
 4. Temperature-actuated, water mixing valves.
 5. Strainers.
 6. Hose bibbs.
 7. Drain valves.
 8. Water-hammer arresters.
 9. Trap-seal primer valves.
 10. Specialty valves.
 11. Flexible connectors.

1.3 ACTION SUBMITTALS

- A. Product Data: For each type of product.
- B. Shop Drawings: For domestic water piping specialties.
1. Include diagrams for power, signal, and control wiring.

1.4 INFORMATIONAL SUBMITTALS

- A. Field quality-control reports.

1.5 CLOSEOUT SUBMITTALS

- A. Operation and Maintenance Data: For domestic water piping specialties to include in emergency, operation, and maintenance manuals.

PART 2 - PRODUCTS

2.1 GENERAL REQUIREMENTS FOR PIPING SPECIALTIES

- A. Potable-water piping, and components shall comply with NSF 61.
- B. Per new Federal Lead-Free Law, any product designed for dispensing potable water meet both the NSF 61 and NSF 372 test standards via third-party testing and certification.

2.2 PERFORMANCE REQUIREMENTS

- A. Minimum Working Pressure for Domestic Water Piping Specialties: 125 psig unless otherwise indicated.

Weedsport Addition to Maintenance Section and Roof Replacement, MP 304.2

2.3 VACUUM BREAKERS

- A. Pipe-Applied, Atmospheric-Type Vacuum Breakers:
1. Manufacturers: Subject to compliance with requirements, available manufacturers offering products that may be incorporated into the Work include, but are not limited to, the following:
 - a. Ames Fire & Waterworks; a division of Watts Water Technologies, Inc.
 - b. Cash Acme; a division of Reliance Worldwide Corporation.
 - c. Conbraco Industries, Inc.
 - d. FEBCO; a division of Watts Water Technologies, Inc.
 - e. Rain Bird Corporation.
 - f. Toro Company (The); Irrigation Div.
 - g. Watts; a division of Watts Water Technologies, Inc.; Watts Regulator Company.
 - h. Zurn Industries, LLC; Plumbing Products Group; Wilkins Water Control Products.
 2. Standard: ASSE 1001.
 3. Size: NPS 1/4 to NPS 3, as required to match connected piping.
 4. Body: Bronze.
 5. Inlet and Outlet Connections: Threaded.
 6. Finish: Chrome plated.
- B. Hose-Connection Vacuum Breakers:
1. Manufacturers: Subject to compliance with requirements, available manufacturers offering products that may be incorporated into the Work include, but are not limited to, the following:
 - a. Arrowhead Brass Products.
 - b. Cash Acme; a division of Reliance Worldwide Corporation.
 - c. Conbraco Industries, Inc.
 - d. Legend Valve.
 - e. MIFAB, Inc.
 - f. Prier Products, Inc.
 - g. Watts; a division of Watts Water Technologies, Inc.; Watts Regulator Company.
 - h. Woodford Manufacturing Company; a division of WCM Industries, Inc.
 - i. Zurn Industries, LLC; Plumbing Products Group; Wilkins Water Control Products.
 2. Standard: ASSE 1011.
 3. Body: Bronze, nonremovable, with manual drain.
 4. Outlet Connection: Garden-hose threaded complying with ASME B1.20.7.
 5. Finish: Chrome or nickel plated.
- C. Pressure Vacuum Breakers:
1. Manufacturers: Subject to compliance with requirements, available manufacturers offering products that may be incorporated into the Work include, but are not limited to, the following:
 - a. Ames Fire & Waterworks; a division of Watts Water Technologies, Inc.
 - b. Conbraco Industries, Inc.
 - c. FEBCO; a division of Watts Water Technologies, Inc.
 - d. Flomatic Corporation.
 - e. Watts; a division of Watts Water Technologies, Inc.; Watts Regulator Company.
 - f. Zurn Industries, LLC; Plumbing Products Group; Wilkins Water Control Products.
 2. Standard: ASSE 1020.

Weedsport Addition to Maintenance Section and Roof Replacement, MP 304.2

3. Operation: Continuous-pressure applications.
4. Pressure Loss: 5 psig maximum, through middle third of flow range.
5. Accessories:
 - a. Valves: Ball type, on inlet and outlet.

2.4 BACKFLOW PREVENTERS

- A. Intermediate Atmospheric-Vent Backflow Preventers:
 1. Manufacturers: Subject to compliance with requirements, available manufacturers offering products that may be incorporated into the Work include, but are not limited to, the following:
 - a. Cash Acme; a division of Reliance Worldwide Corporation.
 - b. Conbraco Industries, Inc.
 - c. FEBCO; a division of Watts Water Technologies, Inc.
 - d. Honeywell International Inc.
 - e. Legend Valve.
 - f. Watts; a division of Watts Water Technologies, Inc.; Watts Regulator Company.
 - g. Zurn Industries, LLC; Plumbing Products Group; Wilkins Water Control Products.
 2. Standard: ASSE 1012.
 3. Operation: Continuous-pressure applications.
 4. Body: Bronze.
 5. End Connections: Union, solder joint.
 6. Finish: Rough bronze.
- B. Reduced-Pressure-Principal Backflow Preventers - **RPZ**:
 1. Manufacturers: Subject to compliance with requirements, available manufacturers offering products that may be incorporated into the Work include, but are not limited to, the following:
 - a. Watts; a division of Watts Water Technologies, Inc.; Watts Regulator Company. Equal to 909 series for main service entrance, 909 or 009 for other internal devices.
 - b. Ames Fire & Waterworks; a division of Watts Water Technologies, Inc.
 - c. Conbraco Industries, Inc.
 - d. FEBCO; a division of Watts Water Technologies, Inc.
 - e. Flomatic Corporation.
 - f. Zurn Industries, LLC; Plumbing Products Group; Wilkins Water Control Products.
 2. Standard: ASSE 1013. And listed as approved by FCCCHR.
 3. Operation: Continuous-pressure applications.
 4. Pressure Loss: 12 psig maximum, through middle third of flow range.
 5. Size: As noted on plan
 6. Body: Bronze for NPS 2 and smaller; cast iron with interior lining that complies with AWWA C550 or that is FDA approved for NPS 2-1/2 and larger.
 7. End Connections: Threaded for NPS 2 and smaller; flanged for NPS 2-1/2 and larger.
 8. Configuration: Designed for horizontal, straight-through flow.
 9. Accessories:
 - a. Valves NPS 2 and Smaller: Ball type with threaded ends on inlet and outlet.
 - b. Valves NPS 2-1/2 and Larger: Outside-screw and yoke-gate type with flanged ends on inlet and outlet.
 - c. Air-Gap Fitting: ASME A112.1.2, matching backflow-preventer connection.

Weedsport Addition to Maintenance Section and Roof Replacement, MP 304.2

10. Provide downspout with Hinged Cover equal to JR Smith 1775 for all through wall drain terminations.
- C. Double-Check, Backflow-Prevention Assemblies – DCV:
1. Manufacturers: Subject to compliance with requirements, available manufacturers offering products that may be incorporated into the Work include, but are not limited to, the following:
 - a. Watts; a division of Watts Water Technologies, Inc.; Watts Regulator Company.
Equal to 007 series.
 - b. Ames Fire & Waterworks; a division of Watts Water Technologies, Inc.
 - c. Conbraco Industries, Inc.
 - d. FEBCO; a division of Watts Water Technologies, Inc.
 - e. Flomatic Corporation.
 - f. Zurn Industries, LLC; Plumbing Products Group; Wilkins Water Control Products.
 2. Standard: ASSE 1015.
 3. Operation: Continuous-pressure applications unless otherwise indicated.
 4. Pressure Loss: 5 psig maximum, through middle third of flow range.
 5. Size: as noted on plans
 6. Body: Bronze for NPS 2 and smaller; cast iron with interior lining that complies with AWWA C550 or that is FDA approved for NPS 2-1/2 and larger.
 7. End Connections: Threaded for NPS 2 and smaller; flanged for NPS 2-1/2 and larger.
 8. Configuration: Designed for horizontal, straight-through flow.
 9. Accessories:
 - a. Valves NPS 2 and Smaller: Ball type with threaded ends on inlet and outlet.
 - b. Valves NPS 2-1/2 and Larger: Outside-screw and yoke-gate type with flanged ends on inlet and outlet.
- D. Beverage-Dispensing-Equipment Backflow Preventers:
1. Manufacturers: Subject to compliance with requirements, available manufacturers offering products that may be incorporated into the Work include, but are not limited to, the following:
 - a. Watts; a division of Watts Water Technologies, Inc.; Watts Regulator Company.,
equal to SD-3
 - b. Conbraco Industries, Inc.
 - c. Zurn Industries, LLC; Plumbing Products Group; Wilkins Water Control Products.
 2. Standard: ASSE 1022.
 3. Operation: Continuous-pressure applications.
 4. Size: NPS 1/4 or NPS 3/8.
 5. Body: Stainless steel.
 6. End Connections: Threaded.
 7. Ensure drainage is available for atmospheric vent
- E. Hose-Connection Backflow Preventers:
1. Manufacturers: Subject to compliance with requirements, available manufacturers offering products that may be incorporated into the Work include, but are not limited to, the following:
 - a. Conbraco Industries, Inc.
 - b. Watts; a division of Watts Water Technologies, Inc.; Watts Regulator Company.
 - c. Woodford Manufacturing Company; a division of WCM Industries, Inc.
 2. Standard: ASSE 1052.

Weedsport Addition to Maintenance Section and Roof Replacement, MP 304.2

3. Operation: Up to 10-foot head of water back pressure.
4. Inlet Size: NPS 1/2 or NPS 3/4.
5. Outlet Size: Garden-hose thread complying with ASME B1.20.7.
6. Capacity: At least 3-gpm flow.

2.5 BALANCING VALVES

- A. Copper-Alloy Calibrated Balancing Valves:
 1. Manufacturers: Subject to compliance with requirements, available manufacturers offering products that may be incorporated into the Work include, but are not limited to, the following:
 - a. Armstrong International, Inc.
 - b. Flo Fab Inc.
 - c. ITT Corporation; Bell & Gossett Div.
 - d. NIBCO Inc.
 - e. TAC.
 - f. TACO Incorporated.
 - g. Watts; a division of Watts Water Technologies, Inc.; Watts Regulator Company.
 2. Type: Ball or Y-pattern globe valve with two readout ports and memory-setting indicator.
 3. Body: Brass or bronze.
 4. Size: Same as connected piping, but not larger than NPS 2.
 5. Accessories: Meter hoses, fittings, valves, differential pressure meter, and carrying case.
- B. Accessories: Meter hoses, fittings, valves, differential pressure meter, and carrying case.

2.6 TEMPERATURE-ACTUATED, WATER MIXING VALVES

- A. Primary, Thermostatic, Water Mixing Valves **MV-1**:
 1. Manufacturers: Subject to compliance with requirements, available manufacturers offering products that may be incorporated into the Work include, but are not limited to, the following:
 - a. Powers; a division of Watts Water Technologies, Inc.- equal to model LFMM431
 - b. Armstrong International, Inc.
 - c. Lawler Manufacturing Company, Inc.
 - d. Leonard Valve Company.
 - e. Symmons Industries, Inc.
 2. Standard: ASSE 1017.
 3. Pressure Rating: 125 psig minimum unless otherwise indicated.
 4. Type: Exposed-mounted, thermostatically controlled, water mixing valve.
 5. Material: Bronze body with corrosion-resistant interior components.
 6. Connections: Threaded inlets and outlet.
 7. Accessories: Manual temperature control, check stops on hot- and cold-water supplies, and adjustable, temperature-control handle.
 8. Tempered-Water Setting: 115 deg F.
 9. Tempered-Water Design Flow Rate: peak 85 gpm.
 10. Selected Valve Flow Rate at 20-psig Pressure Drop: 20 gpm.
 11. Valve Finish: Rough bronze.
 12. Piping Finish: Copper.

2.7 STRAINERS FOR DOMESTIC WATER PIPING**A. Y-Pattern Strainers:**

1. Pressure Rating: 125 psig minimum unless otherwise indicated.
2. Body: Bronze for NPS 2 and smaller; cast iron with interior lining that complies with AWWA C550 or that is FDA approved, epoxy coated and for NPS 2-1/2 and larger.
3. End Connections: Threaded for NPS 2 and smaller; flanged for NPS 2-1/2 and larger.
4. Screen: Stainless steel with round perforations unless otherwise indicated.
5. Drain: Factory-installed, hose-end drain valve.

2.8 HOSE BIBBS**A. Hose Bibbs **HB-1** Mild Climate Concealed Hose connection:**

1. Manufacturers: Subject to compliance with requirements, available manufacturers offering products that may be incorporated into the Work include, but are not limited to, the following:
 - a. JR Smith.
 - b. Zurn, Equal to Z1350
2. Standard: ASME A112.18.1 for sediment faucets.
3. Body Material: Bronze.
4. Seat: Bronze, replaceable.
5. Supply Connections: NPS 1/2 or NPS 3/4 threaded or solder-joint inlet.
6. Outlet Connection: Garden-hose thread complying with ASME B1.20.7.
7. Pressure Rating: 125 psig.
8. Vacuum Breaker: Integral nonremovable, drainable, hose-connection vacuum breaker complying with ASSE 1011.
9. Finish for Finished Rooms: Chrome or nickel plated.
10. Operation for Finished Rooms: Operating key.
11. Include operating key with each operating-key hose bibb.
12. Include integral wall flange with each chrome- or nickel-plated hose bibb.

B. Nonfreezing Wall Hydrants **NFHB:**

1. Manufacturers: Subject to compliance with requirements, available manufacturers offering products that may be incorporated into the Work include, but are not limited to, the following:
 - a. Josam Company.
 - b. Smith, Jay R. Mfg. Co.; Division of Smith Industries, Inc.
 - c. Tyler Pipe; Wade Div.
 - d. Watts Drainage Products.
 - e. Zurn Industries, LLC; Plumbing Products Group; Specification Drainage Products. Equal to Z1305
2. Standard: ASME A112.21.3M for concealed-outlet, self-draining wall hydrants.
3. Pressure Rating: 125 psig.
4. Operation: Loose key.
5. Casing and Operating Rod: Of length required to match wall thickness. Include wall clamp.
6. Inlet: NPS 3/4 or NPS 1.
7. Outlet: Concealed, with integral vacuum breaker and garden-hose thread complying with ASME B1.20.7.
8. Box: Deep, flush mounted with cover.
9. Box and Cover Finish: Polished nickel bronze.

Weedsport Addition to Maintenance Section and Roof Replacement, MP 304.2

10. Outlet: Exposed, with integral vacuum breaker and garden-hose thread complying with ASME B1.20.7.
11. Nozzle and Wall-Plate Finish: Polished nickel bronze.
12. Operating Keys(s): One with each wall hydrant.

2.9 DRAIN VALVES

A. Ball-Valve-Type, Hose-End Drain Valves:

1. Standard: MSS SP-110 for standard-port, two-piece ball valves.
2. Pressure Rating: 400-psig minimum CWP.
3. Size: NPS 3/4.
4. Body: Copper alloy.
5. Ball: Chrome-plated brass.
6. Seats and Seals: Replaceable.
7. Handle: Vinyl-covered steel.
8. Inlet: Threaded or solder joint.
9. Outlet: Threaded, short nipple with garden-hose thread complying with ASME B1.20.7 and cap with brass chain.

B. Stop-and-Waste Drain Valves:

1. Standard: MSS SP-110 for ball valves or MSS SP-80 for gate valves.
2. Pressure Rating: 200-psig minimum CWP or Class 125.
3. Size: NPS 3/4.
4. Body: Copper alloy or ASTM B 62 bronze.
5. Drain: NPS 1/8 side outlet with cap.

2.10 WATER-HAMMER ARRESTERS

A. Water-Hammer Arresters :

1. Manufacturers: Subject to compliance with requirements, available manufacturers offering products that may be incorporated into the Work include, but are not limited to, the following:
 - a. AMTROL, Inc.
 - b. Josam Company.
 - c. MIFAB, Inc.
 - d. Sioux Chief Manufacturing Company, Inc.
 - e. Smith, Jay R. Mfg. Co.; Division of Smith Industries, Inc.
 - f. Tyler Pipe; Wade Div.
 - g. Watts Drainage Products.
 - h. Zurn Industries, LLC; Plumbing Products Group; Specification Drainage Products.
2. Standard: ASSE 1010 or PDI-WH 201.
3. Type: Metal bellows or Copper tube with piston.
4. Size: ASSE 1010, Sizes AA and A through F, or PDI-WH 201, Sizes A through F.

2.11 TRAP-SEAL PRIMER DEVICE

A. Supply-Type, Trap-Seal Primer Device :

1. Manufacturers: Subject to compliance with requirements, available manufacturers offering products that may be incorporated into the Work include, but are not limited to, the following:
 - a. MIFAB, Inc.

Weedsport Addition to Maintenance Section and Roof Replacement, MP 304.2

- b. Precision Plumbing Products, Inc.
 - c. Sioux Chief Manufacturing Company, Inc.
 - d. Smith, Jay R. Mfg. Co.; Division of Smith Industries, Inc.
 - e. Watts; a division of Watts Water Technologies, Inc.; Watts Regulator Company.
2. Standard: ASSE 1018.
 3. Pressure Rating: 125 psig minimum.
 4. Body: Bronze.
 5. Inlet and Outlet Connections: NPS 1/2 threaded, union, or solder joint.
 6. Gravity Drain Outlet Connection: NPS 1/2 threaded or solder joint.
 7. Finish: Chrome plated, or rough bronze for units used with pipe or tube that is not chrome finished.

2.12 SPECIALTY VALVES

- A. Comply with requirements for general-duty metal valves in Section 220523 "General-Duty Valves for Plumbing Piping."

2.13 FLEXIBLE CONNECTORS

- A. Manufacturers: Subject to compliance with requirements, available manufacturers offering products that may be incorporated into the Work include, but are not limited to, the following:
 1. Flex-Hose Co., Inc.
 2. Flexicraft Industries.
 3. Flex Pression, Ltd.
 4. Flex-Weld Incorporated.
 5. Hyspan Precision Products, Inc.
 6. Mercer Gasket & Shim, Inc.
 7. Metraflex, Inc.
 8. Unaflex.Universal Metal Hose; a Hyspan company.
- B. Bronze-Hose Flexible Connectors: Corrugated-bronze tubing with bronze wire-braid covering and ends brazed to inner tubing.
 1. Working-Pressure Rating: Minimum 200 psig.
 2. End Connections NPS 2 and Smaller: Threaded copper pipe or plain-end copper tube.
 3. End Connections NPS 2-1/2 and Larger: Flanged copper alloy.
- C. Stainless-Steel-Hose Flexible Connectors: Corrugated-stainless-steel tubing with stainless-steel wire-braid covering and ends welded to inner tubing.
 1. Working-Pressure Rating: Minimum 200 psig.
 2. End Connections NPS 2 and Smaller: Threaded steel-pipe nipple.
 3. End Connections NPS 2-1/2 and Larger: Flanged steel nipple.

PART 3 - EXECUTION

3.1 INSTALLATION

- A. Install backflow preventers in each water supply to mechanical equipment and systems and to other equipment and water systems that may be sources of contamination. Comply with authorities having jurisdiction.
 1. Locate backflow preventers in same room as connected equipment or system.
 2. Install drain for backflow preventers with atmospheric-vent drain connection with air-gap fitting, fixed air-gap fitting, or equivalent positive pipe separation of at least two pipe

Weedsport Addition to Maintenance Section and Roof Replacement, MP 304.2

- diameters in drain piping and pipe-to-floor drain. Locate air-gap device attached to or under backflow preventer. Simple air breaks are unacceptable for this application.
3. Do not install bypass piping around backflow preventers.
- B. Install water-control valves with inlet and outlet shutoff valves and bypass with globe valve. Install pressure gages on inlet and outlet.
 - C. Install balancing valves in locations where they can easily be adjusted.
 - D. Install temperature-actuated, water mixing valves with check stops or shutoff valves on inlets and with shutoff valve on outlet.
 1. Install cabinet-type units recessed in or surface mounted on wall as specified.
 - E. Install Y-pattern strainers for water on supply side of each water pressure-reducing valve.
 - F. Install water-hammer arresters in water piping according to PDI-WH 201.
 - G. Install supply-type, trap-seal primer valves with outlet piping pitched down toward drain trap a minimum of 1 percent, and connect to floor-drain body, trap, or inlet fitting. Adjust valve for proper flow.

3.2 CONNECTIONS

- A. Comply with requirements for ground equipment in Section 260526 "Grounding and Bonding for Electrical Systems."

3.3 LABELING AND IDENTIFYING

- A. Equipment Nameplates and Signs: Install engraved plastic-laminate equipment nameplate or sign on or near each of the following:
 1. Pressure vacuum breakers.
 2. Intermediate atmospheric-vent backflow preventers.
 3. Reduced-pressure-principle backflow preventers.
 4. Double-check, backflow-prevention assemblies.
 5. Dual-check-valve backflow preventers.
 6. Double-check, detector-assembly backflow preventers.
 7. Water pressure-reducing valves.
 8. Calibrated balancing valves.
 9. Primary, thermostatic, water mixing valves.
 10. Supply-type, trap-seal primer valves.
 11. Trap-seal primer systems.

3.4 FIELD QUALITY CONTROL

- A. Test each backflow prevention device including, reduced pressure principle backflow, double check backflow and/or double-check detector assembly backflow as required by NYS Cross Connection Control Guidelines, and as required by the manufacturer.
 1. Complete test reports as required by NYS DOH, including the DOH-1013 form (part A).
- B. Domestic water piping specialties will be considered defective if they do not pass tests and inspections.
- C. Prepare test and inspection reports.

3.5 ADJUSTING

- A. Set field-adjustable pressure set points of water pressure-reducing valves.

Weedsport Addition to Maintenance Section and Roof Replacement, MP 304.2

- B. Set field-adjustable flow set points of balancing valves.
- C. Set field-adjustable temperature set points of temperature-actuated, water mixing valves.

END OF SECTION 221119

SECTION 221123 - DOMESTIC WATER PUMPS

PART 1 - GENERAL

1.1 RELATED DOCUMENTS

- A. Drawings and general provisions of the Contract, including General and Supplementary Conditions and Division 01 Specification Sections, apply to this Section.

1.2 SUMMARY

- A. Section Includes:
 1. Horizontally mounted, in-line, close-coupled centrifugal pumps for hot water circulation.

1.3 DEFINITIONS

- A. Low Voltage: As defined in NFPA 70 for circuits and equipment operating at less than 50 V or for remote-control, signaling power-limited circuits.

1.4 ACTION SUBMITTALS

- A. Product Data: For each type of product indicated. Include materials of construction, rated capacities, certified performance curves with operating points plotted on curves, operating characteristics, electrical characteristics, and furnished specialties and accessories.

1.5 CLOSEOUT SUBMITTALS

- A. Operation and Maintenance Data: For domestic water pumps to include in operation and maintenance manuals.

1.6 QUALITY ASSURANCE

- A. Electrical Components, Devices, and Accessories: Listed and labeled as defined in NFPA 70, by a qualified testing agency, and marked for intended location and application.
- B. UL Compliance: Comply with UL 778 for motor-operated water pumps.

1.7 DELIVERY, STORAGE, AND HANDLING

- A. Retain shipping flange protective covers and protective coatings during storage.
- B. Protect bearings and couplings against damage.
- C. Comply with pump manufacturer's written rigging instructions for handling.

1.8 COORDINATION

- A. Coordinate sizes and locations of concrete bases with actual equipment provided.

PART 2 - PRODUCTS

2.1 HORIZONTALLY MOUNTED, IN-LINE, CLOSE-COUPLED CENTRIFUGAL PUMPS – RP-1

- A. Manufacturers: Subject to compliance with requirements, available manufacturers offering products that may be incorporated into the Work include, but are not limited to, the following:

Weedsport Addition to Maintenance Section and Roof Replacement, MP 304.2

1. Grundfos Pumps Corporation, U.S.A. Equal to UPS 15-55 SFC
 2. Armstrong Pumps Inc.
 3. Bell & Gossett Domestic Pump; ITT Corporation.
 4. Pentair Pump Group; Aurora Pump.
- B. Description: Factory-assembled and -tested, in-line, single-stage, close-coupled, overhung-impeller centrifugal pumps designed for installation with pump and motor shaft mounted horizontal.
- C. Pump Construction:
1. Casing: Radially split with threaded companion-flange connections for pumps with NPS 2 pipe connections and flanged connections for pumps with NPS 2-1/2 pipe connections.
 2. Impeller: Statically and dynamically balanced, closed, and keyed to shaft.
 3. Shaft and Shaft Sleeve: Steel shaft with deflector, with copper-alloy shaft sleeve. Include water slinger on shaft between motor and seal.
 4. Seal: Mechanical, with carbon-steel rotating ring, stainless-steel spring, ceramic seat, and rubber bellows and gasket.
 5. Bearings: Oil-lubricated; bronze-journal or ball type.
 6. Shaft Coupling: Flexible, capable of absorbing torsional vibration and shaft misalignment.
- D. Motor: Single speed, with grease-lubricated ball bearings; and resiliently or rigidly mounted to pump casing.
- E. Capacities and Characteristics:
1. Capacity: 3 GPM.
 2. Total Dynamic Head: 12 feet.
 3. Casing Material: stainless steel
 4. Impeller Material: ASTM B 584, stainless steel.
 5. Minimum Working Pressure: 175 PSIG.
 6. Maximum Continuous Operating Temperature: 225 deg F.
 7. Inlet and Outlet Size: 2 bolt flanges.
 8. Pump Control: Thermostat.
 9. Motor Horsepower: 87 Watt
 10. Electrical Characteristics:
 - a. Volts: 120.
 - b. Phases: Single.
 - c. Hertz: 60.

2.2 MOTORS

- A. Comply with NEMA designation, temperature rating, service factor, enclosure type, and efficiency requirements for motors.
1. Motor Sizes: Minimum size as indicated. If not indicated, large enough so driven load will not require motor to operate in service factor range above 1.0.

2.3 CONTROLS

- A. Thermostats: Electric; adjustable for control of hot-water circulation pump.
1. Type: Water-immersion temperature sensor, for installation in piping.
 2. Range: 65 to 200 deg F.
 3. Enclosure: NEMA 250
 4. Operation of Pump: On or off.

Weedsport Addition to Maintenance Section and Roof Replacement, MP 304.2

5. Transformer: Provide if required.
6. Power Requirement: 120 V.
7. Settings: Start pump at 105 deg F and stop pump at 110 deg F.

PART 3 - EXECUTION

3.1 EXAMINATION

- A. Examine roughing-in of domestic-water-piping system to verify actual locations of connections before pump installation.

3.2 PUMP INSTALLATION

- A. Comply with HI 1.4.
- B. Install in-line, sealless centrifugal pumps with shaft horizontal unless otherwise indicated.
- C. Install horizontally mounted, in-line, close-coupled centrifugal pumps with shaft(s) horizontal.
- D. Install vertically mounted, in-line, close-coupled centrifugal pumps with shaft vertical.
- E. Install continuous-thread hanger rods and spring hangers of size required to support pump weight.
 1. Comply with requirements for hangers and supports specified in Section 220529 "Hangers and Supports for Plumbing Piping and Equipment."
- F. Install thermostats in hot-water return piping.

3.3 CONNECTIONS

- A. Comply with requirements for piping specified in Section 221116 "Domestic Water Piping." Drawings indicate general arrangement of piping, fittings, and specialties.
- B. Install piping adjacent to pumps to allow service and maintenance.
- C. Connect domestic water piping to pumps. Install suction and discharge piping equal to or greater than size of pump nozzles.
 1. Install flexible connectors adjacent to pumps in suction and discharge piping of the following pumps:
 - a. Horizontally mounted, in-line, close-coupled centrifugal pumps.
 - b. Comply with requirements for flexible connectors specified in Section 221116 "Domestic Water Piping."
 2. Install shutoff valve and strainer on suction side of each pump, and check, shutoff, and throttling valves on discharge side of each pump. Install valves same size as connected piping. Comply with requirements for valves specified in Section 220523 "General-Duty Valves for Plumbing Piping" and comply with requirements for strainers specified in Section 221119 "Domestic Water Piping Specialties."
 3. Install pressure gage at suction of each pump and pressure gage at discharge of each pump. Install at integral pressure-gage tappings where provided or install pressure-gage connectors in suction and discharge piping around pumps. Comply with requirements for pressure gages and snubbers specified in Section 220519 "Meters and Gages for Plumbing Piping."
- D. Connect thermostats to pumps that they control.
- E. Interlock pump between water heater and hot-water storage tank with water heater burner and time-delay relay.

Weedsport Addition to Maintenance Section and Roof Replacement, MP 304.2

3.4 STARTUP SERVICE

- A. Engage a factory-authorized service representative to perform startup service.
 - 1. Complete installation and startup check according to manufacturer's written instructions.
 - 2. Check piping connections for tightness.
 - 3. Clean strainers on suction piping.
 - 4. Set thermostats for automatic starting and stopping operation of pumps.
 - 5. Perform the following startup checks for each pump before starting:
 - a. Verify bearing lubrication.
 - b. Verify that pump is free to rotate by hand and that pump for handling hot liquid is free to rotate with pump hot and cold. If pump is bound or drags, do not operate until cause of trouble is determined and corrected.
 - c. Verify that pump is rotating in the correct direction.
 - 6. Prime pump by opening suction valves and closing drains and prepare pump for operation.
 - 7. Start motor.
 - 8. Open discharge valve slowly.
 - 9. Adjust temperature settings on thermostats.
 - 10. Adjust timer settings.

3.5 ADJUSTING

- A. Adjust domestic water pumps to function smoothly and lubricate as recommended by manufacturer.
- B. Adjust initial temperature set points.
- C. Set field-adjustable switches and circuit-breaker trip ranges as indicated.

END OF SECTION 221123

SECTION 221124 – NATURAL GAS PIPING

PART 1 - GENERAL

1.1 RELATED DOCUMENTS

- A. Drawings and general provisions of the Contract, including General and Supplementary Conditions and Division 01 Specification Sections, apply to this Section.

1.2 SUMMARY

- A. Section Includes:
1. Pipes, tubes, and fittings.
 2. Piping specialties.
 3. Piping and tubing joining materials.
 4. Valves.
 5. Pressure regulators.
 6. Service meters.
 7. Concrete bases.

1.3 DEFINITIONS

- A. Finished Spaces: Spaces other than mechanical and electrical equipment rooms, furred spaces, pipe and duct shafts, unheated spaces immediately below roof, spaces above ceilings, unexcavated spaces, crawlspaces, and tunnels.
- B. Exposed, Interior Installations: Exposed to view indoors. Examples include finished occupied spaces and mechanical equipment rooms.
- C. Exposed, Exterior Installations: Exposed to view outdoors or subject to outdoor ambient temperatures and weather conditions. Examples include rooftop locations.

1.4 PERFORMANCE REQUIREMENTS

- A. Minimum Operating-Pressure Ratings:
1. Piping and Valves: 100 psig minimum unless otherwise indicated.
 2. Service Regulators: 100 psig minimum unless otherwise indicated.
 3. Minimum Operating Pressure of Service Meter: 5 psig.
- B. Natural-Gas System Pressure within Buildings: 0.5 psig or less.

1.5 ACTION SUBMITTALS

- A. Product Data: For each type of the following:
1. Piping specialties.
 2. Corrugated, stainless-steel tubing with associated components.
 3. Valves. Include pressure rating, capacity, settings, and electrical connection data of selected models.
 4. Pressure regulators. Indicate pressure ratings and capacities.
 5. Service meters. Indicate pressure ratings and capacities. Include bypass fittings.
 6. Dielectric fittings.

Weedsport Addition to Maintenance Section and Roof Replacement, MP 304.2

1.6 INFORMATIONAL SUBMITTALS

- A. Coordination Drawings: Plans and details, drawn to scale, on which natural-gas piping is shown and coordinated with other installations, using input from installers of the items involved.
- B. Site Survey: Plans, drawn to scale, on which natural-gas piping is shown and coordinated with other services and utilities.
- C. Qualification Data: For qualified professional engineer.
- D. Welding certificates.
- E. Field quality-control reports.

1.7 CLOSEOUT SUBMITTALS

- A. Operation and Maintenance Data: For pressure regulators and service meters to include in emergency, operation, and maintenance manuals.

1.8 QUALITY ASSURANCE

- A. Steel Support Welding Qualifications: Qualify procedures and personnel according to AWS D1.1/D1.1M, "Structural Welding Code - Steel."
- B. Pipe Welding Qualifications: Qualify procedures and operators according to ASME Boiler and Pressure Vessel Code.
- C. Electrical Components, Devices, and Accessories: Listed and labeled as defined in NFPA 70, by a qualified testing agency, and marked for intended location and application.

1.9 DELIVERY, STORAGE, AND HANDLING

- A. Handling Flammable Liquids: Remove and dispose of liquids from existing natural-gas piping according to requirements of authorities having jurisdiction.
- B. Deliver pipes and tubes with factory-applied end caps. Maintain end caps through shipping, storage, and handling to prevent pipe end damage and to prevent entrance of dirt, debris, and moisture.
- C. Store and handle pipes and tubes having factory-applied protective coatings to avoid damaging coating and protect from direct sunlight.
- D. Protect stored PE pipes and valves from direct sunlight.

1.10 PROJECT CONDITIONS

- A. Perform site survey, research public utility records, and verify existing utility locations. Contact utility-locating service for area where Project is located.

1.11 COORDINATION

- A. Coordinate sizes and locations of concrete bases with actual equipment provided.

PART 2 - PRODUCTS**2.1 PIPES, TUBES, AND FITTINGS**

- A. Steel Pipe: ASTM A 53/A 53M, black steel, Schedule 40, Type E or S, Grade B.
 - 1. Malleable-Iron Threaded Fittings: ASME B16.3, Class 150, standard pattern.

Weedsport Addition to Maintenance Section and Roof Replacement, MP 304.2

2. Wrought-Steel Welding Fittings: ASTM A 234/A 234M for butt welding and socket welding.
 3. Unions: ASME B16.39, Class 150, malleable iron with brass-to-iron seat, ground joint, and threaded ends.
 4. Forged-Steel Flanges and Flanged Fittings: ASME B16.5, minimum Class 150, including bolts, nuts, and gaskets of the following material group, end connections, and facings:
 - a. Material Group: 1.1.
 - b. End Connections: Threaded or butt welding to match pipe.
 - c. Lapped Face: Not permitted underground.
 - d. Gasket Materials: ASME B16.20, metallic, flat, asbestos free, aluminum o-rings, and spiral-wound metal gaskets.
 - e. Bolts and Nuts: ASME B18.2.1, carbon steel aboveground and stainless-steel underground.
 5. Protective Coating for Underground Piping: Factory-applied, three-layer coating of epoxy, adhesive, and PE.
 - a. Joint Cover Kits: Epoxy paint, adhesive, and heat-shrink PE sleeves.
 6. Mechanical Couplings:
 - a. Manufacturers: Subject to compliance with requirements, available manufacturers offering products that may be incorporated into the Work include, but are not limited to, the following:
 - 1) Dresser Piping Specialties; Division of Dresser, Inc.
 - 2) Smith-Blair, Inc.
 - b. Stainless-steel flanges and tube with epoxy finish.
 - c. Buna-nitrile seals.
 - d. Stainless-steel bolts, washers, and nuts.
 - e. Coupling shall be capable of joining PE pipe to PE pipe, steel pipe to PE pipe, or steel pipe to steel pipe.
 - f. Steel body couplings installed underground on plastic pipe shall be factory equipped with anode.
- B. Corrugated, Stainless-Steel Tubing: Comply with ANSI/IAS LC 1.
1. Manufacturers: Subject to compliance with requirements, available manufacturers offering products that may be incorporated into the Work include, but are not limited to, the following:
 - a. OmegaFlex, Inc.
 - b. Parker Hannifin Corporation; Parflex Division.
 - c. Titeflex.
 - d. Tru-Flex Metal Hose Corp.
 2. Tubing: ASTM A 240/A 240M, corrugated, Series 300 stainless steel.
 3. Coating: PE with flame retardant.
 - a. Surface-Burning Characteristics: As determined by testing identical products according to ASTM E 84 by a qualified testing agency. Identify products with appropriate markings of applicable testing agency.
 - 1) Flame-Spread Index: 25 or less.
 - 2) Smoke-Developed Index: 50 or less.

Weedsport Addition to Maintenance Section and Roof Replacement, MP 304.2

4. Fittings: Copper-alloy mechanical fittings with ends made to fit and listed for use with corrugated stainless-steel tubing and capable of metal-to-metal seal without gaskets. Include brazing socket or threaded ends complying with ASME B1.20.1.
 5. Striker Plates: Steel, designed to protect tubing from penetrations.
 6. Manifolds: Malleable iron or steel with factory-applied protective coating. Threaded connections shall comply with ASME B1.20.1 for pipe inlet and corrugated tubing outlets.
 7. Operating-Pressure Rating: 5 psig.
 8. Bonding and grounding per NEC and NYS Fuel Gas Code.
- C. PE Pipe: ASTM D 2513, SDR 11.
1. PE Fittings: ASTM D 2683, socket-fusion type or ASTM D 3261, butt-fusion type with dimensions matching PE pipe.
 2. PE Transition Fittings: Factory-fabricated fittings with PE pipe complying with ASTM D 2513, SDR 11; and steel pipe complying with ASTM A 53/A 53M, black steel, Schedule 40, Type E or S, Grade B.
 3. Anodeless Service-Line Risers: Factory fabricated, and leak tested.
 - a. Underground Portion: PE pipe complying with ASTM D 2513, SDR 11 inlet.
 - b. Casing: Steel pipe complying with ASTM A 53/A 53M, Schedule 40, black steel, Type E or S, Grade B, with corrosion-protective coating covering. Vent casing aboveground.
 - c. Aboveground Portion: PE transition fitting.
 - d. Outlet shall be threaded or flanged or suitable for welded connection.
 - e. Tracer wire connection.
 - f. Ultraviolet shield.
 - g. Stake supports with factory finish to match steel pipe casing or carrier pipe.
 4. Transition Service-Line Risers: Factory fabricated, and leak tested.
 - a. Underground Portion: PE pipe complying with ASTM D 2513, SDR 11 inlet connected to steel pipe complying with ASTM A 53/A 53M, Schedule 40, Type E or S, Grade B, with corrosion-protective coating for aboveground outlet.
 - b. Outlet shall be threaded or flanged or suitable for welded connection.
 - c. Bridging sleeve over mechanical coupling.
 - d. Factory-connected anode.
 - e. Tracer wire connection.
 - f. Ultraviolet shield.
 - g. Stake supports with factory finish to match steel pipe casing or carrier pipe.
 5. Plastic Mechanical Couplings, NPS 1-1/2 and Smaller: Capable of joining PE pipe to PE pipe.
 - a. Manufacturers: Subject to compliance with requirements, available manufacturers offering products that may be incorporated into the Work include, but are not limited to, the following:
 - 1) Lyall, R. W. & Company, Inc.
 - 2) Mueller Co.; Gas Products Div.
 - 3) Perfection Corporation; a subsidiary of American Meter Company.
 - 4) .
 - b. PE body with molded-in, stainless-steel support ring.
 - c. Buna-nitrile seals.
 - d. Acetal collets.
 - e. Electro-zinc-plated steel stiffener.

Weedspport Addition to Maintenance Section and Roof Replacement, MP 304.2

6. Plastic Mechanical Couplings, NPS 2 and Larger: Capable of joining PE pipe to PE pipe, steel pipe to PE pipe, or steel pipe to steel pipe.
 - a. Manufacturers: Subject to compliance with requirements, available manufacturers offering products that may be incorporated into the Work include, but are not limited to, the following:
 - 1) Lyall, R. W. & Company, Inc.
 - 2) Mueller Co.; Gas Products Div.
 - 3) Perfection Corporation; a subsidiary of American Meter Company.
 - b. Fiber-reinforced plastic body.
 - c. PE body tube.
 - d. Buna-nitrile seals.
 - e. Acetal collets.
 - f. Stainless-steel bolts, nuts, and washers.
7. Steel Mechanical Couplings: Capable of joining plain-end PE pipe to PE pipe, steel pipe to PE pipe, or steel pipe to steel pipe.
 - a. Manufacturers: Subject to compliance with requirements, available manufacturers offering products that may be incorporated into the Work include, but are not limited to, the following:
 - 1) Dresser Piping Specialties; Division of Dresser, Inc.
 - 2) Smith-Blair, Inc.
 - b. Stainless-steel flanges and tube with epoxy finish.
 - c. Buna-nitrile seals.
 - d. Stainless-steel bolts, washers, and nuts.
 - e. Factory-installed anode for steel-body couplings installed underground.

2.2 PIPING SPECIALTIES

- A. Appliance Flexible Connectors:
 1. Indoor, Fixed-Appliance Flexible Connectors: Comply with ANSI Z21.24.
 2. Indoor, Movable-Appliance Flexible Connectors: Comply with ANSI Z21.69.
 3. Outdoor, Appliance Flexible Connectors: Comply with ANSI Z21.75.
 4. Corrugated stainless-steel tubing with polymer coating.
 5. Operating-Pressure Rating: 0.5 psig.
 6. End Fittings: Zinc-coated steel.
 7. Threaded Ends: Comply with ASME B1.20.1.
 8. Maximum Length: 72 inches
- B. Y-Pattern Strainers:
 1. Body: ASTM A 126, Class B, cast iron with bolted cover and bottom drain connection.
 2. End Connections: Threaded ends for NPS 2 and smaller; flanged ends for NPS 2-1/2 and larger.
 3. Strainer Screen: [40] [60]-mesh startup strainer and perforated stainless-steel basket with 50 percent free area.
 4. CWP Rating: 125 psig.
- C. Weatherproof Vent Cap: Cast- or malleable-iron increaser fitting with corrosion-resistant wire screen, with free area at least equal to cross-sectional area of connecting pipe and threaded-end connection.

2.3 JOINING MATERIALS

- A. Joint Compound and Tape: Suitable for natural gas.

Weedsport Addition to Maintenance Section and Roof Replacement, MP 304.2

- B. Welding Filler Metals: Comply with AWS D10.12/D10.12M for welding materials appropriate for wall thickness and chemical analysis of steel pipe being welded.
- C. Brazing Filler Metals: Alloy with melting point greater than 1000 deg F complying with AWS A5.8/A5.8M. Brazing alloys containing more than 0.05 percent phosphorus are prohibited.

2.4 MANUAL GAS SHUTOFF VALVES

- A. See "Underground Manual Gas Shutoff Valve Schedule" and "Aboveground Manual Gas Shutoff Valve Schedule" Articles for where each valve type is applied in various services.
- B. General Requirements for Metallic Valves, NPS 2 and Smaller: Comply with ASME B16.33.
 - 1. CWP Rating: 125 psig.
 - 2. Threaded Ends: Comply with ASME B1.20.1.
 - 3. Dryseal Threads on Flare Ends: Comply with ASME B1.20.3.
 - 4. Tamperproof Feature: Locking feature for valves indicated in "Underground Manual Gas Shutoff Valve Schedule" and "Aboveground Manual Gas Shutoff Valve Schedule" Articles.
 - 5. Listing: Listed and labeled by an NRTL acceptable to authorities having jurisdiction for valves 1 inch and smaller.
 - 6. Service Mark: Valves 1-1/4 inches to NPS 2 shall have initials "WOG" permanently marked on valve body.
- C. General Requirements for Metallic Valves, NPS 2-1/2 and Larger: Comply with ASME B16.38.
 - 1. CWP Rating: 125 psig.
 - 2. Flanged Ends: Comply with ASME B16.5 for steel flanges.
 - 3. Tamperproof Feature: Locking feature for valves indicated in "Underground Manual Gas Shutoff Valve Schedule" and "Aboveground Manual Gas Shutoff Valve Schedule" Articles.
 - 4. Service Mark: Initials "WOG" shall be permanently marked on valve body.
- D. Two-Piece, Full-Port, Bronze Ball Valves with Bronze Trim: MSS SP-110.S
 - 1. Manufacturers: Subject to compliance with requirements, available manufacturers offering products that may be incorporated into the Work include, but are not limited to, the following:
 - a. BrassCraft Manufacturing Company; a Masco company.
 - b. Conbraco Industries, Inc.; Apollo Div.
 - c. Lyall, R. W. & Company, Inc.
 - d. McDonald, A. Y. Mfg. Co.
 - e. Perfection Corporation; a subsidiary of American Meter Company.
 - 2. Body: Bronze, complying with ASTM B 584.
 - 3. Ball: Chrome-plated bronze.
 - 4. Stem: Bronze; blowout proof.
 - 5. Seats: Reinforced TFE; blowout proof.
 - 6. Packing: Threaded-body packnut design with adjustable-stem packing.
 - 7. Ends: Threaded, flared, or socket as indicated in "Underground Manual Gas Shutoff Valve Schedule" and "Aboveground Manual Gas Shutoff Valve Schedule" Articles.
 - 8. CWP Rating: 600 psig.
 - 9. Listing: Valves NPS 1 and smaller shall be listed and labeled by an NRTL acceptable to authorities having jurisdiction.
 - 10. Service: Suitable for natural-gas service with "WOG" indicated on valve body.

Weedsport Addition to Maintenance Section and Roof Replacement, MP 304.2

- E. Bronze Plug Valves: MSS SP-78.
1. Manufacturers: Subject to compliance with requirements, available manufacturers offering products that may be incorporated into the Work include, but are not limited to, the following:
 - a. Lee Brass Company.
 - b. McDonald, A. Y. Mfg. Co.
 2. Body: Bronze, complying with ASTM B 584.
 3. Plug: Bronze.
 4. Ends: Threaded, socket, or flanged as indicated in "Underground Manual Gas Shutoff Valve Schedule" and "Aboveground Manual Gas Shutoff Valve Schedule" Articles.
 5. Operator: Square head or lug type with tamperproof feature where indicated.
 6. Pressure Class: 125 psig.
 7. Listing: Valves NPS 1 and smaller shall be listed and labeled by an NRTL acceptable to authorities having jurisdiction.
 8. Service: Suitable for natural-gas service with "WOG" indicated on valve body.
- F. Cast-Iron, Lubricated Plug Valves: MSS SP-78.
1. Manufacturers: Subject to compliance with requirements, available manufacturers offering products that may be incorporated into the Work include, but are not limited to, the following:
 - a. Flowserve.
 - b. Homestead Valve; a division of Olson Technologies, Inc.
 - c. McDonald, A. Y. Mfg. Co.
 - d. Milliken Valve Company.
 - e. Mueller Co.; Gas Products Div.
 - f. R&M Energy Systems, A Unit of Robbins & Myers, Inc.
 2. Body: Cast iron, complying with ASTM A 126, Class B.
 3. Plug: Bronze or nickel-plated cast iron.
 4. Seat: Coated with thermoplastic.
 5. Stem Seal: Compatible with natural gas.
 6. Ends: Threaded or flanged as indicated in "Underground Manual Gas Shutoff Valve Schedule" and "Aboveground Manual Gas Shutoff Valve Schedule" Articles.
 7. Operator: Square head or lug type with tamperproof feature where indicated.
 8. Pressure Class: 125 psig.
 9. Listing: Valves NPS 1 and smaller shall be listed and labeled by an NRTL acceptable to authorities having jurisdiction.
 10. Service: Suitable for natural-gas service with "WOG" indicated on valve body.
- G. Valve Boxes:
1. Cast-iron, two-section box.
 2. Top section with cover with "GAS" lettering.
 3. Bottom section with base to fit over valve and barrel a minimum of 5 inches in diameter.
 4. Adjustable cast-iron extensions of length required for depth of bury.
 5. Include tee-handle, steel operating wrench with socket end fitting valve nut or flat head, and with stem of length required to operate valve.

2.5 MOTORIZED GAS VALVES

- A. Automatic Gas Valves: Comply with ANSI Z21.21.
1. Manufacturers: Subject to compliance with requirements, provide products by one of the following:

Weedsport Addition to Maintenance Section and Roof Replacement, MP 304.2

- a. Dungs, Karl, Inc.
 - b. Eaton.
 - c. Eclipse Innovative Thermal Technologies.
 - d. Honeywell Building Solutions; Honeywell International, Inc.
 - e. Johnson Controls.
2. Body: Brass or aluminum.
 3. Seats and Disc: Nitrile rubber.
 4. Springs and Valve Trim: Stainless steel.
 5. Normally closed.
 6. Visual position indicator.
 7. **Electrical or Mechanical** operator for actuation by appliance automatic shutoff device.
- B. Electrically Operated Valves: Comply with UL 429.
1. Manufacturers: Subject to compliance with requirements, provide products by one of the following:
 - a. ASCO. Equal to 8043
 - b. WATTS.
 2. Equipment labeled **GSV-1**: Provide electrically Operated Gas Valves: UL 429, bronze, aluminum, or cast-iron body solenoid valve; 120-V ac, 60 Hz, Class B, continuous-duty molded coil. Include NEMA ISC 6, Type 4, coil enclosure and electrically opened and closed dual coils. Valve position shall normally be closed. Product equal to Asco 108 Relay panel (**RP**) with series 8215 solenoid valve and master control station (**MCS**) catalog number 216C89. Provide master control station with necessary recessed (or surface mounted) box. See drawing for location and # of master control stations.

2.6 PRESSURE REGULATORS

- A. General Requirements:
1. Single stage and suitable for natural gas.
 2. Steel jacket and corrosion-resistant components.
 3. Elevation compensator.
 4. End Connections: Threaded for regulators NPS 2 and smaller; flanged for regulators NPS 2-1/2 and larger.
- B. Line Pressure Regulators: Comply with ANSI Z21.80.
1. Manufacturers: Subject to compliance with requirements, available manufacturers offering products that may be incorporated into the Work include, but are not limited to, the following:
 - a. Actaris.
 - b. American Meter Company.
 - c. Eclipse Combustion, Inc.
 - d. Fisher Control Valves and Regulators; Division of Emerson Process Management.
 - e. Invensys.
 - f. Maxitrol Company.
 - g. Richards Industries; Jordan Valve Div.
 2. Body and Diaphragm Case: Cast iron or die-cast aluminum.
 3. Springs: Zinc-plated steel; interchangeable.

Weedsport Addition to Maintenance Section and Roof Replacement, MP 304.2

4. Diaphragm Plate: Zinc-plated steel.
 5. Seat Disc: Nitrile rubber resistant to gas impurities, abrasion, and deformation at the valve port.
 6. Orifice: Aluminum; interchangeable.
 7. Seal Plug: Ultraviolet-stabilized, mineral-filled nylon.
 8. Single-port, self-contained regulator with orifice no larger than required at maximum pressure inlet, and no pressure sensing piping external to the regulator.
 9. Pressure regulator shall maintain discharge pressure setting downstream, and not exceed 150 percent of design discharge pressure at shutoff.
 10. Overpressure Protection Device: Factory mounted on pressure regulator.
 11. Atmospheric Vent: Factory- or field-installed, stainless-steel screen in opening if not connected to vent piping.
 12. Maximum Inlet Pressure: 10 psig.
- C. Appliance Pressure Regulators: Comply with ANSI Z21.18.
1. Manufacturers: Subject to compliance with requirements, available manufacturers offering products that may be incorporated into the Work include, but are not limited to, the following:
 - a. Canadian Meter Company Inc.
 - b. Eaton Corporation; Controls Div.
 - c. Harper Wyman Co.
 - d. Maxitrol Company.
 - e. SCP, Inc.
 2. Body and Diaphragm Case: Die-cast aluminum.
 3. Springs: Zinc-plated steel; interchangeable.
 4. Diaphragm Plate: Zinc-plated steel.
 5. Seat Disc: Nitrile rubber.
 6. Seal Plug: Ultraviolet-stabilized, mineral-filled nylon.
 7. Factory-Applied Finish: Minimum three-layer polyester and polyurethane paint finish.
 8. Regulator may include vent limiting device, instead of vent connection, if approved by authorities having jurisdiction.
 9. Maximum Inlet Pressure: 2 psig.

2.7 DIELECTRIC FITTINGS

- A. General Requirements: Assembly of copper alloy and ferrous materials with separating nonconductive insulating material. Include end connections compatible with pipes to be joined.
- B. Dielectric Unions:
1. Manufacturers: Subject to compliance with requirements, available manufacturers offering products that may be incorporated into the Work include, but are not limited to, the following:
 - a. Capitol Manufacturing Company.
 - b. Central Plastics Company.
 - c. Hart Industries International, Inc.
 - d. Jomar International Ltd.
 - e. Matco-Norca, Inc.
 - f. McDonald, A. Y. Mfg. Co.
 - g. Watts Regulator Co.; a division of Watts Water Technologies, Inc.
 - h. Wilkins; a Zurn company.
 2. Description:
 - a. Standard: ASSE 1079.

Weedsport Addition to Maintenance Section and Roof Replacement, MP 304.2

- b. Pressure Rating: 125 psig minimum at 180 deg F.
 - c. End Connections: Solder-joint copper alloy and threaded ferrous.
- C. Dielectric Flanges:
- 1. Manufacturers: Subject to compliance with requirements, available manufacturers offering products that may be incorporated into the Work include, but are not limited to, the following:
 - a. Capitol Manufacturing Company.
 - b. Central Plastics Company.
 - c. Matco-Norca, Inc.
 - d. Watts Regulator Co.; a division of Watts Water Technologies, Inc.
 - e. Wilkins; a Zurn company.
 - 2. Description:
 - a. Standard: ASSE 1079.
 - b. Factory-fabricated, bolted, companion-flange assembly.
 - c. Pressure Rating: 125 psig minimum at 180 deg F.
 - d. End Connections: Solder-joint copper alloy and threaded ferrous; threaded solder-joint copper alloy and threaded ferrous.
- D. Dielectric-Flange Insulating Kits:
- 1. Manufacturers: Subject to compliance with requirements, available manufacturers offering products that may be incorporated into the Work include, but are not limited to, the following:
 - a. Advance Products & Systems, Inc.
 - b. Calpico, Inc.
 - c. Central Plastics Company.
 - d. Pipeline Seal and Insulator, Inc.
 - 2. Description:
 - a. Nonconducting materials for field assembly of companion flanges.
 - b. Pressure Rating: 150 psig.
 - c. Gasket: Neoprene or phenolic.
 - d. Bolt Sleeves: Phenolic or polyethylene.
 - e. Washers: Phenolic with steel backing washers.

2.8 LABELING AND IDENTIFYING

- A. Detectable Warning Tape: Acid- and alkali-resistant, PE film warning tape manufactured for marking and identifying underground utilities, a minimum of 6 inches wide and 4 mils thick, continuously inscribed with a description of utility, with metallic core encased in a protective jacket for corrosion protection, detectable by metal detector when tape is buried up to 30 inches deep; colored yellow.

PART 3 - EXECUTION

3.1 EXAMINATION

- A. Examine roughing-in for natural-gas piping system to verify actual locations of piping connections before equipment installation.
- B. Proceed with installation only after unsatisfactory conditions have been corrected.

Weedsport Addition to Maintenance Section and Roof Replacement, MP 304.2

3.2 PREPARATION

- A. Close equipment shutoff valves before turning off natural gas to premises or piping section.
- B. Inspect natural-gas piping according to the New York State Fuel Gas Code to determine that natural-gas utilization devices are turned off in piping section affected.
- C. Comply with the New York State Fuel Gas Code requirements for prevention of accidental ignition.

3.3 OUTDOOR PIPING INSTALLATION

- A. Comply with the New York State Fuel Gas Code for installation and purging of natural-gas piping.
- B. Install underground, natural-gas piping buried at least **36 inches** below finished grade. Comply with requirements in Section 312000 "Earth Moving" for excavating, trenching, and backfilling.
 - 1. If natural-gas piping is installed less than 36 inches below finished grade, install it in containment conduit.
- C. Install underground, PE, natural-gas piping according to ASTM D 2774.
- D. Steel Piping with Protective Coating:
 - 1. Apply joint cover kits to pipe after joining to cover, seal, and protect joints.
 - 2. Repair damage to PE coating on pipe as recommended in writing by protective coating manufacturer.
 - 3. Replace pipe having damaged PE coating with new pipe.
- E. Copper Tubing with Protective Coating:
 - 1. Apply joint cover kits over tubing to cover, seal, and protect joints.
 - 2. Repair damage to PE coating on pipe as recommended in writing by protective coating manufacturer.
- F. Install fittings for changes in direction and branch connections.
- G. Install pressure gage upstream and downstream from each service regulator. Pressure gages are specified in Section 220519 "Meters and Gages for PLUMBING Piping."

3.4 INDOOR PIPING INSTALLATION

- A. Comply with the New York State Fuel Gas Code for installation and purging of natural-gas piping.
- B. Drawing plans, schematics, and diagrams indicate general location and arrangement of piping systems. Indicated locations and arrangements are used to size pipe and calculate friction loss, expansion, and other design considerations. Install piping as indicated unless deviations to layout are approved on Coordination Drawings.
- C. Arrange for pipe spaces, chases, slots, sleeves, and openings in building structure during progress of construction, to allow for mechanical installations.
- D. Install piping in concealed locations unless otherwise indicated and except in equipment rooms and service areas.
- E. Install piping indicated to be exposed and piping in equipment rooms and service areas at right angles or parallel to building walls. Diagonal runs are prohibited unless specifically indicated otherwise.
- F. Install piping above accessible ceilings to allow sufficient space for ceiling panel removal.

Weedsport Addition to Maintenance Section and Roof Replacement, MP 304.2

- G. Locate valves for easy access.
- H. Install natural-gas piping at uniform grade of 2 percent down toward drip and sediment traps.
- I. Install piping free of sags and bends.
- J. Install fittings for changes in direction and branch connections.
- K. Verify final equipment locations for roughing-in.
- L. Comply with requirements in Sections specifying gas-fired appliances and equipment for roughing-in requirements.
- M. Drips and Sediment Traps: Install drips at points where condensate may collect, including service-meter outlets. Locate where accessible to permit cleaning and emptying. Do not install where condensate is subject to freezing.
 - 1. Construct drips and sediment traps using tee fitting with bottom outlet plugged or capped. Use nipple a minimum length of 3 pipe diameters, but not less than 3 inches long and same size as connected pipe. Install with space below bottom of drip to remove plug or cap.
- N. Extend relief vent connections for service regulators, line regulators, and overpressure protection devices to outdoors and terminate with weatherproof vent cap.
- O. Conceal pipe installations in walls, pipe spaces, utility spaces, above ceilings, below grade or floors, and in floor channels unless indicated to be exposed to view.
- P. Concealed Location Installations: Except as specified below, install concealed natural-gas piping and piping installed under the building in containment conduit constructed of steel pipe with welded joints as described in Part 2. Install a vent pipe from containment conduit to outdoors and terminate with weatherproof vent cap.
 - 1. Above Accessible Ceilings: Natural-gas piping, fittings, valves, and regulators may be installed in accessible spaces without containment conduit.
 - 2. In Floors: Install natural-gas piping with welded or brazed joints and protective coating in cast-in-place concrete floors. Cover piping to be cast in concrete slabs with minimum of 1-1/2 inches of concrete. Piping may not be in physical contact with other metallic structures such as reinforcing rods or electrically neutral conductors. Do not embed piping in concrete slabs containing quick-set additives or cinder aggregate.
 - 3. In Floor Channels: Install natural-gas piping in floor channels. Channels must have cover and be open to space above cover for ventilation.
 - 4. In Walls or Partitions: Protect tubing installed inside partitions or hollow walls from physical damage using steel striker barriers at rigid supports.
 - a. Exception: Tubing passing through partitions or walls does not require striker barriers.
 - 5. Prohibited Locations:
 - a. Do not install natural-gas piping in or through circulating air ducts, clothes or trash chutes, chimneys or gas vents (flues), ventilating ducts, or dumbwaiter or elevator shafts.
 - b. Do not install natural-gas piping in solid walls or partitions.
- Q. Use eccentric reducer fittings to make reductions in pipe sizes. Install fittings with level side down.
- R. Connect branch piping from top or side of horizontal piping.
- S. Install unions in pipes NPS 2 and smaller, adjacent to each valve, at final connection to each piece of equipment. Unions are not required at flanged connections.

Weedsport Addition to Maintenance Section and Roof Replacement, MP 304.2

- T. Do not use natural-gas piping as grounding electrode.
- U. Install strainer on inlet of each line-pressure regulator and automatic or electrically operated valve.
- V. Install pressure gage upstream and downstream from each line regulator. Pressure gages are specified in Section 22 "Meters and Gages for Plumbing Piping."
- W. Install sleeves for piping penetrations of walls, ceilings, and floors. Comply with requirements for sleeves specified in Section 22 "Sleeves and Sleeve Seals for Plumbing Piping."
- X. Install sleeve seals for piping penetrations of concrete walls and slabs. Comply with requirements for sleeve seals specified in Section 22 "Sleeves and Sleeve Seals for Plumbing Piping."
- Y. Install escutcheons for piping penetrations of walls, ceilings, and floors. Comply with requirements for escutcheons specified in Section 22 "Escutcheons for Plumbing Piping."

3.5 SERVICE-METER ASSEMBLY INSTALLATION

- A. Install service-meter assemblies aboveground as directed by Gas Utility Company.
- B. Install metal shutoff valves upstream from service regulators. Shutoff valves are not required at second regulators if two regulators are installed in series.
- C. Install strainer on inlet of service-pressure regulator and meter set.
- D. Install service regulators mounted outside with vent outlet horizontal or facing down. Install screen in vent outlet if not integral with service regulator.
- E. Install metal shutoff valves upstream from service meters. Install dielectric fittings downstream from service meters.
- F. Install service meters downstream from pressure regulators.
- G. Install metal bollards to protect meter assemblies. Comply with requirements in Section 055000 "Metal Fabrications" for pipe bollards.

3.6 VALVE INSTALLATION

- A. Install manual gas shutoff valve for each gas appliance ahead of corrugated stainless-steel tubing, aluminum, or copper connector.
- B. Install underground valves with valve boxes.
- C. Install regulators and overpressure protection devices with maintenance access space adequate for servicing and testing.
- D. Install earthquake valves aboveground outside buildings according to listing.
- E. Install anode for metallic valves in underground PE piping.

3.7 PIPING JOINT CONSTRUCTION

- A. Ream ends of pipes and tubes and remove burrs.
- B. Remove scale, slag, dirt, and debris from inside and outside of pipe and fittings before assembly.
- C. Threaded Joints:
 1. Thread pipe with tapered pipe threads complying with ASME B1.20.1.
 2. Cut threads full and clean using sharp dies.

Weedsport Addition to Maintenance Section and Roof Replacement, MP 304.2

3. Ream threaded pipe ends to remove burrs and restore full inside diameter of pipe.
 4. Apply appropriate tape or thread compound to external pipe threads unless dryseal threading is specified.
 5. Damaged Threads: Do not use pipe or pipe fittings with threads that are corroded or damaged. Do not use pipe sections that have cracked or open welds.
- D. Welded Joints:
1. Construct joints according to AWS D10.12/D10.12M, using qualified processes and welding operators.
 2. Bevel plain ends of steel pipe.
 3. Patch factory-applied protective coating as recommended by manufacturer at field welds and where damage to coating occurs during construction.
- E. Brazed Joints: Construct joints according to AWS's "Brazing Handbook," "Pipe and Tube" Chapter.
- F. Flanged Joints: Install gasket material, size, type, and thickness appropriate for natural-gas service. Install gasket concentrically positioned.
- G. Flared Joints: Cut tubing with roll cutting tool. Flare tube end with tool to result in flare dimensions complying with SAE J513. Tighten finger tight, then use wrench. Do not overtighten.
- H. PE Piping Heat-Fusion Joints: Clean and dry joining surfaces by wiping with clean cloth or paper towels. Join according to ASTM D 2657.
1. Plain-End Pipe and Fittings: Use butt fusion.
 2. Plain-End Pipe and Socket Fittings: Use socket fusion.

3.8 HANGER AND SUPPORT INSTALLATION

- A. Install seismic restraints on piping.
- B. Comply with requirements for pipe hangers and supports specified in Section 22 "Hangers and Supports for Piping and Equipment."
- C. Install hangers for horizontal steel piping with the following maximum spacing and minimum rod sizes:
1. NPS 1 and Smaller: Maximum span, 96 inches; minimum rod size, 3/8 inch.
 2. NPS 1-1/4: Maximum span, 108 inches; minimum rod size, 3/8 inch.
 3. NPS 1-1/2 and NPS 2: Maximum span, 108 inches; minimum rod size, 3/8 inch.
 4. NPS 2-1/2 to NPS 3-1/2: Maximum span, 10 feet; minimum rod size, 1/2 inch.
 5. NPS 4 and Larger: Maximum span, 10 feet; minimum rod size, 5/8 inch.
- D. Install hangers for horizontal drawn-temper copper tubing with the following maximum spacing and minimum rod sizes:
1. NPS 3/8: Maximum span, 48 inches; minimum rod size, 3/8 inch.
 2. NPS 1/2 and NPS 5/8: Maximum span, 72 inches; minimum rod size, 3/8 inch.
 3. NPS 3/4 and NPS 7/8: Maximum span, 84 inches; minimum rod size, 3/8 inch.
 4. NPS 1: Maximum span, 96 inches; minimum rod size, 3/8 inch.
- E. Install hangers for horizontal, corrugated stainless-steel tubing with the following maximum spacing and minimum rod sizes:
1. NPS 3/8: Maximum span, 48 inches; minimum rod size, 3/8 inch.
 2. NPS 1/2: Maximum span, 72 inches; minimum rod size, 3/8 inch.
 3. NPS 3/4 and Larger: Maximum span, 96 inches; minimum rod size, 3/8 inch.

Weedsport Addition to Maintenance Section and Roof Replacement, MP 304.2

3.9 CONNECTIONS

- A. Connect to utility's gas main according to utility's procedures and requirements.
- B. Install natural-gas piping electrically continuous and bonded to gas appliance equipment grounding conductor of the circuit powering the appliance according to NFPA 70.
- C. Install piping adjacent to appliances to allow service and maintenance of appliances.
- D. Connect piping to appliances using manual gas shutoff valves and unions. Install valve within 72 inches of each gas-fired appliance and equipment. Install union between valve and appliances or equipment.
- E. Sediment Traps: Install tee fitting with capped nipple in bottom to form drip, as close as practical to inlet of each appliance.

3.10 LABELING AND IDENTIFYING

- A. Install detectable warning tape directly above gas piping, 12 inches below finished grade, except 6 inches below subgrade under pavements and slabs.

3.11 PAINTING

- A. Comply with requirements in Section 099113 "Exterior Painting" and Section 099123 "Interior Painting" for painting interior and exterior natural-gas piping.
- B. Paint exposed, exterior metal piping, valves, service regulators, service meters and meter bars, earthquake valves, and piping specialties, except components, with factory-applied paint or protective coating.
 - 1. Alkyd System: MPI EXT 5.1D.
 - a. Prime Coat: Alkyd anticorrosive metal primer.
 - b. Intermediate Coat: Exterior alkyd enamel matching topcoat.
 - c. Topcoat: Exterior alkyd enamel (semigloss).
 - d. Color: Gray.
- C. Paint exposed, interior metal piping, valves, service regulators, service meters and meter bars, earthquake valves, and piping specialties, except components, with factory-applied paint or protective coating.
 - 1. Alkyd System: MPI INT 5.1E.
 - a. Prime Coat: Alkyd anticorrosive metal primer.
 - b. Intermediate Coat: Interior alkyd matching topcoat.
 - c. Topcoat: Interior alkyd (eggshell).
 - d. Color: Gray.
- D. Damage and Touchup: Repair marred and damaged factory-applied finishes with materials and by procedures to match original factory finish.

3.12 CONCRETE BASES

- A. Concrete Bases: Anchor equipment to concrete base.
 - 1. Construct concrete bases of dimensions indicated, but not less than 4 inches larger in both directions than supported unit.
 - 2. Install dowel rods to connect concrete base to concrete floor. Unless otherwise indicated, install dowel rods on 18-inch centers around the full perimeter of the base.
 - 3. Install epoxy-coated anchor bolts for supported equipment that extend through concrete base, and anchor into structural concrete floor.

Weedsport Addition to Maintenance Section and Roof Replacement, MP 304.2

4. Place and secure anchorage devices. Use supported equipment manufacturer's setting drawings, templates, diagrams, instructions, and directions furnished with items to be embedded.
5. Install anchor bolts to elevations required for proper attachment to supported equipment.
6. Use 3000-psig, 28-day, compressive-strength concrete and reinforcement as specified in Section 033 "Cast-in-Place Concrete."

3.13 FIELD QUALITY CONTROL

- A. Perform tests and inspections.
- B. Tests and Inspections:
 1. Test, inspect, and purge natural gas according to NFPA 54 and the NYS Fuel Gas Code and authorities having jurisdiction.
 2. For gas piping with working pressure up to 14" WC, the completed line is to be pressure tested with air or inert gas for a minimum of one hour at 50 psig.
- C. Natural-gas piping will be considered defective if it does not pass tests and inspections.
- D. Reports: Prepare inspection and test reports and have them signed by authorities having jurisdiction. Submit all reports to Architect.

3.14 DEMONSTRATION

- A. Engage a factory-authorized service representative to train Owner's maintenance personnel to adjust, operate, and maintain earthquake valves.

3.15 OUTDOOR PIPING SCHEDULE

- A. Underground natural gas piping shall be one of the following:
 1. PE pipe and fittings joined by heat fusion, or mechanical couplings; service-line risers with tracer wire terminated in an accessible location.
 2. Steel pipe with wrought-steel fittings and welded joints, or mechanical couplings. Coat pipe and fittings with protective coating for steel piping.
- B. Aboveground natural gas piping shall be one of the following:
 1. Steel pipe with malleable-iron fittings and threaded joints.
 2. Steel pipe with wrought-steel fittings and welded joints.
- C. Containment Conduit: Steel pipe with wrought-steel fittings and welded joints. Coat pipe and fittings with protective coating for steel piping.

3.16 INDOOR PIPING SCHEDULE FOR SYSTEM PRESSURES LESS THAN 0.5 PSIG

- A. Aboveground, branch piping NPS 1 and smaller shall be one of the following:
 1. Corrugated stainless-steel tubing with mechanical fittings having socket or threaded ends to match adjacent piping.
 2. Steel pipe with malleable-iron fittings and threaded joints.
- B. Aboveground, distribution piping shall be one of the following:
 1. Steel pipe with malleable-iron fittings and threaded joints.
 2. Steel pipe with wrought-steel fittings and welded joints.
- C. Underground, below building, piping shall be one of the following:
 1. Steel pipe with wrought-steel fittings and welded joints.
 2. Corrugated stainless-steel tubing with no joints, routed in vented steel conduit.

Weedsport Addition to Maintenance Section and Roof Replacement, MP 304.2

- D. Containment Conduit: Steel pipe with wrought-steel fittings and welded joints. Coat pipe and fittings with protective coating for steel piping.
- E. Containment Conduit Vent Piping: Steel pipe with malleable-iron fittings and threaded or wrought-steel fittings with welded joints. Coat underground pipe and fittings with protective coating for steel piping.

3.17 INDOOR PIPING SCHEDULE FOR SYSTEM PRESSURES MORE THAN 0.5 PSIG AND LESS THAN 5 PSIG

- A. Aboveground, branch piping NPS 1 and smaller shall be one of the following:
 1. Corrugated stainless-steel tubing with mechanical fittings having socket or threaded ends to match adjacent piping.
 2. Steel pipe with malleable-iron fittings and threaded joints.
- B. Aboveground, distribution piping shall be one of the following:
 1. Steel pipe with malleable-iron fittings and threaded joints.
 2. Steel pipe with steel welding fittings and welded joints.
- C. Underground, below building, piping shall be the following:
 1. Steel pipe with wrought-steel fittings and welded joints.
- D. Containment Conduit: Steel pipe with wrought-steel fittings and welded joints. Coat underground pipe and fittings with protective coating for steel piping.
- E. Containment Conduit Vent Piping: Steel pipe with malleable-iron fittings and threaded or wrought-steel fittings with welded joints. Coat underground pipe and fittings with protective coating for steel piping.

3.18 INDOOR PIPING SCHEDULE FOR SYSTEM PRESSURES MORE THAN 5 PSIG

- A. Aboveground Piping: Maximum operating pressure more than 5 psig.
- B. Aboveground, Branch Piping: Steel pipe with steel welding fittings and welded joints.
- C. Aboveground, distribution piping shall be the following:
 1. Steel pipe with steel welding fittings and welded joints.
- D. Underground, below building, piping shall be the following:
 1. Steel pipe with wrought-steel fittings and welded joints.
- E. Containment Conduit: Steel pipe with wrought-steel fittings and welded joints. Coat pipe and fittings with protective coating for steel piping.
- F. Containment Conduit Vent Piping: Steel pipe with malleable-iron fittings and threaded or wrought-steel fittings with welded joints. Coat underground pipe and fittings with protective coating for steel piping.

3.19 UNDERGROUND MANUAL GAS SHUTOFF VALVE SCHEDULE

- A. Connections to Existing Gas Piping: Use valve and fitting assemblies made for tapping utility's gas mains and listed by an NRTL.
- B. Underground:
 1. PE valves.
 2. NPS 2 and Smaller: Bronze plug valves.
 3. NPS 2-1/2 and Larger: Cast-iron, lubricated plug valves.

3.20 ABOVEGROUND MANUAL GAS SHUTOFF VALVE SCHEDULE

- A. Valves for pipe sizes NPS 2 and smaller at service meter shall be one of the following:
 - 1. Two-piece, full-port, bronze ball valves with bronze trim.
 - 2. Bronze plug valve.
- B. Valves for pipe sizes NPS 2-1/2 and larger at service meter shall be one of the following:
 - 1. Two-piece, full-port, bronze ball valves with bronze trim.
 - 2. Bronze plug valve.
 - 3. Cast-iron, lubricated plug valve.
- C. Distribution piping valves for pipe sizes NPS 2 and smaller shall be one of the following:
 - 1. Two-piece, full-port, bronze ball valves with bronze trim.
 - 2. Bronze plug valve.
- D. Distribution piping valves for pipe sizes NPS 2-1/2 and larger shall be one of the following:
 - 1. Bronze plug valve.
 - 2. Cast-iron, lubricated plug valve.
- E. Valves in branch piping for single appliance shall be one of the following:
 - 1. Two-piece, full-port, bronze ball valves with bronze trim.
 - 2. Bronze plug valve.

END OF SECTION 221124

SECTION 221316 - SANITARY WASTE AND VENT PIPING

PART 1 - GENERAL

1.1 RELATED DOCUMENTS

- A. Drawings and general provisions of the Contract, including General and Supplementary Conditions and Division 01 Specification Sections, apply to this Section.

1.2 SUMMARY

- A. Section Includes:
 - 1. Pipe, tube, and fittings.
 - 2. Specialty pipe fittings.
 - 3. Encasement for underground metal piping.

1.3 PERFORMANCE REQUIREMENTS

- A. Components and installation shall be capable of withstanding the following minimum working pressure unless otherwise indicated:
 - 1. Soil, Waste, and Vent Piping: 10-foot head of water.
 - 2. Waste, Force-Main Piping: 100 psig.
- B. Seismic Performance: Soil, waste, and vent piping and support and installation shall withstand the effects of earthquake motions determined according to ASCE/SEI 7.

1.4 ACTION SUBMITTALS

- A. Product Data: For each type of product indicated.

1.5 INFORMATIONAL SUBMITTALS

- A. Seismic Qualification Certificates: For waste and vent piping, accessories, and components, from manufacturer.
 - 1. Basis for Certification: Indicate whether withstand certification is based on actual test of assembled components or on calculation.
 - 2. Detailed description of piping anchorage devices on which the certification is based and their installation requirements.
- B. Field quality-control reports.

1.6 QUALITY ASSURANCE

- A. Piping materials shall bear label, stamp, or other markings of specified testing agency, as well as collective trademark of the Cast Iron Soil Pipe Institute (CISPI) and be listed by NSF International.

1.7 PROJECT CONDITIONS

- A. Interruption of Existing Sanitary Waste Service: Do not interrupt service to facilities occupied by Owner or others unless permitted under the following conditions and then only after arranging to provide temporary service according to requirements indicated:
 - 1. Notify Architect, Construction Manager, and Owner no fewer than two days in advance of proposed interruption of sanitary waste service.

Weedsport Addition to Maintenance Section and Roof Replacement, MP 304.2

2. Do not proceed with interruption of sanitary waste service without Owner's written permission.

PART 2 - PRODUCTS

2.1 PIPING MATERIALS

- A. Comply with requirements in "Piping Schedule" Article for applications of pipe, tube, fitting materials, and joining methods for specific services, service locations, and pipe sizes.

2.2 HUB-AND-SPIGOT, CAST-IRON SOIL PIPE AND FITTINGS

- A. Pipe and Fittings: ASTM A 74, Service class(es).
- B. Gaskets: ASTM C 564, rubber.
- C. Calking Materials: ASTM B 29, pure lead and oakum or hemp fiber.

2.3 HUBLESS, CAST-IRON SOIL PIPE AND FITTINGS

- A. Pipe and Fittings: ASTM A 888 or CISPI 301.
- B. Solvent Stack Fittings: ASME B16.45 or ASSE 1043, hubless, cast-iron aerator and deaerator drainage fittings.
- C. CISPI, Hubless-Piping Couplings:
 1. Manufacturers: Subject to compliance with requirements, available manufacturers offering products that may be incorporated into the Work include, but are not limited to, the following:
 - a. ANACO-Husky.
 - b. Fernco Inc.
 - c. Mission Rubber Company; a division of MCP Industries, Inc.
 - d. Tyler Pipe.
 2. Standards: ASTM C 1277 and CISPI 310.
 3. Description: Stainless-steel corrugated shield with stainless-steel bands and tightening devices; and ASTM C 564, rubber sleeve with integral, center pipe stop.
- D. Heavy-Duty, Hubless-Piping Couplings:
 1. Manufacturers: Subject to compliance with requirements, available manufacturers offering products that may be incorporated into the Work include, but are not limited to, the following:
 - a. ANACO-Husky.
 - b. Clamp-All Corp.
 - c. Mission Rubber Company; a division of MCP Industries, Inc.
 - d. Tyler Pipe.
 2. Standards: ASTM C 1277 and ASTM C 1540.
 3. Description: Stainless-steel shield with stainless-steel bands and tightening devices; and ASTM C 564, rubber sleeve with integral, center pipe stop.

2.4 COPPER TUBE AND FITTINGS

- A. Copper DWV Tube: ASTM B 306, drainage tube, drawn temper.
- B. Copper Drainage Fittings: ASME B16.23, cast copper or ASME B16.29, wrought copper, solder-joint fittings.

Weedsport Addition to Maintenance Section and Roof Replacement, MP 304.2

- C. Hard Copper Tube: ASTM B 88, Type L water tube, drawn temper.
- D. Copper Pressure Fittings:
 - 1. Copper Fittings: ASME B16.18, cast-copper-alloy or ASME B16.22, wrought-copper, solder-joint fittings. Furnish wrought-copper fittings if indicated.
 - 2. Copper Unions: MSS SP-123, copper-alloy, hexagonal-stock body with ball-and-socket, metal-to-metal seating surfaces, and solder-joint or threaded ends.
- E. Copper Flanges: ASME B16.24, Class 150, cast copper with solder-joint end.
 - 1. Flange Gasket Materials: ASME B16.21, full-face, flat, nonmetallic, asbestos-free, 1/8-inch maximum thickness unless thickness or specific material is indicated.
 - 2. Flange Bolts and Nuts: ASME B18.2.1, carbon steel unless otherwise indicated.
- F. Solder: ASTM B 32, lead free with ASTM B 813, water-flushable flux.

2.5 SPECIALTY PIPE FITTINGS

- A. Transition Couplings:
 - 1. General Requirements: Fitting or device for joining piping with small differences in OD's or of different materials. Include end connections same size as and compatible with pipes to be joined.
 - 2. Fitting-Type Transition Couplings: Manufactured piping coupling or specified piping system fitting.
 - 3. Shielded, Nonpressure Transition Couplings:
 - a. Manufacturers: Subject to compliance with requirements, available manufacturers offering products that may be incorporated into the Work include, but are not limited to, the following:
 - 1) Mission Rubber Company; a division of MCP Industries, Inc.
 - b. Standard: ASTM C 1460.
 - c. Description: Elastomeric or rubber sleeve with full-length, corrosion-resistant outer shield and corrosion-resistant-metal tension band and tightening mechanism on each end.
 - 4. Pressure Transition Couplings:
 - a. Manufacturers: Subject to compliance with requirements, available manufacturers offering products that may be incorporated into the Work include, but are not limited to, the following:
 - 1) Dresser, Inc.
 - 2) EBAA Iron, Inc.
 - 3) JCM Industries, Inc.
 - 4) Romac Industries, Inc.
 - 5) Smith-Blair, Inc.; a Sensus company.
 - 6) The Ford Meter Box Company, Inc.
 - 7) Viking Johnson.
 - b. Standard: AWWA C219.
 - c. Description: Metal, sleeve-type same size as, with pressure rating at least equal to, and ends compatible with, pipes to be joined.
 - d. Center-Sleeve Material: Stainless steel.
 - e. Gasket Material: Natural or synthetic rubber.
 - f. Metal Component Finish: Corrosion-resistant coating or material.
- B. Dielectric Fittings:

Weedsport Addition to Maintenance Section and Roof Replacement, MP 304.2

1. General Requirements: Assembly of copper alloy and ferrous materials with separating nonconductive insulating material. Include end connections compatible with pipes to be joined.
2. Dielectric Unions:
 - a. Manufacturers: Subject to compliance with requirements, available manufacturers offering products that may be incorporated into the Work include, but are not limited to, the following:
 - 1) Capitol Manufacturing Company.
 - 2) Hart Industries International, Inc.
 - 3) Jomar International Ltd.
 - 4) Matco-Norca, Inc.
 - 5) Watts Regulator Co.; a division of Watts Water Technologies, Inc.
 - 6) Wilkins; a Zurn company.
 - b. Description:
 - 1) Standard: ASSE 1079.
 - 2) Pressure Rating: 125 psig minimum at 180 deg F.
 - 3) End Connections: Solder-joint copper alloy and threaded ferrous.
3. Dielectric Flanges:
 - a. Manufacturers: Subject to compliance with requirements, available manufacturers offering products that may be incorporated into the Work include, but are not limited to, the following:
 - 1) Capitol Manufacturing Company.
 - 2) Matco-Norca, Inc.
 - 3) Watts Regulator Co.; a division of Watts Water Technologies, Inc.
 - 4) Wilkins; a Zurn company.
 - b. Description:
 - 1) Standard: ASSE 1079.
 - 2) Factory-fabricated, bolted, companion-flange assembly.
 - 3) Pressure Rating: 125 psig minimum at 180 deg F.
 - 4) End Connections: Solder-joint copper alloy and threaded ferrous; threaded solder-joint copper alloy and threaded ferrous.
4. Dielectric-Flange Insulating Kits:
 - a. Manufacturers: Subject to compliance with requirements, available manufacturers offering products that may be incorporated into the Work include, but are not limited to, the following:
 - 1) Advance Products & Systems, Inc.
 - 2) Calpico, Inc.
 - 3) Pipeline Seal and Insulator, Inc.
 - b. Description:
 - 1) Nonconducting materials for field assembly of companion flanges.
 - 2) Pressure Rating: 150 psig.
 - 3) Gasket: Neoprene or phenolic.
 - 4) Bolt Sleeves: Phenolic or polyethylene.
 - 5) Washers: Phenolic with steel backing washers.
5. Dielectric Nipples:
 - a. Manufacturers: Subject to compliance with requirements, available manufacturers offering products that may be incorporated into the Work include, but are not limited to, the following:
 - 1) Elster Perfection.
 - 2) Grinnell Mechanical Products.

Weedsport Addition to Maintenance Section and Roof Replacement, MP 304.2

- 3) Matco-Norca, Inc.
 - 4) Precision Plumbing Products, Inc.
 - 5) Victaulic Company.
- b. Description:
- 1) Standard: IAPMO PS 66
 - 2) Electroplated steel nipple.
 - 3) Pressure Rating: 300 psig at 225 deg F.
 - 4) End Connections: Male threaded or grooved.
 - 5) Lining: Inert and noncorrosive, propylene.

PART 3 - EXECUTION

3.1 EARTH MOVING

- A. Comply with requirements for excavating, trenching, and backfilling specified in Section 312000 "Earth Moving."

3.2 PIPING INSTALLATION

- A. Drawing plans, schematics, and diagrams indicate general location and arrangement of piping systems. Indicated locations and arrangements were used to size pipe and calculate friction loss, expansion, pump sizing, and other design considerations. Install piping as indicated unless deviations to layout are approved on coordination drawings.
- B. Install piping in concealed locations unless otherwise indicated and except in equipment rooms and service areas.
- C. Install piping indicated to be exposed and piping in equipment rooms and service areas at right angles or parallel to building walls. Diagonal runs are prohibited unless specifically indicated otherwise.
- D. Install piping above accessible ceilings to allow sufficient space for ceiling panel removal.
- E. Install piping to permit valve servicing.
- F. Install piping at indicated slopes.
- G. Install piping free of sags and bends.
- H. Install fittings for changes in direction and branch connections.
- I. Install piping to allow application of insulation.
- J. Install seismic restraints on piping.
- K. Vent termination through roof shall be min. 18" above roof.
- L. Make changes in direction for soil and waste drainage and vent piping using appropriate branches, bends, and long-sweep bends. Sanitary tees and short-sweep 1/4 bends may be used on vertical stacks if change in direction of flow is from horizontal to vertical. Use long-turn, double Y-branch and 1/8-bend fittings if two fixtures are installed back to back or side by side with common drain pipe. Straight tees, elbows, and crosses may be used on vent lines. Do not change direction of flow more than 90 degrees. Use proper size of standard increasers and reducers if pipes of different sizes are connected. Reducing size of drainage piping in direction of flow is prohibited.

Weedsport Addition to Maintenance Section and Roof Replacement, MP 304.2

- M. Lay buried building drainage piping beginning at low point of each system. Install true to grades and alignment indicated, with unbroken continuity of invert. Place hub ends of piping upstream. Install required gaskets according to manufacturer's written instructions for use of lubricants, cements, and other installation requirements. Maintain swab in piping and pull past each joint as completed.
- N. Install soil and waste drainage and vent piping at the following minimum slopes unless otherwise indicated:
 - 1. Building Sanitary Drain: 2 percent downward in direction of flow for piping NPS 3 and smaller; 1 percent downward in direction of flow for piping NPS 4 and larger.
 - 2. Horizontal Sanitary Drainage Piping: 2 percent downward in direction of flow.
 - 3. Vent Piping: 1 percent down toward vertical fixture vent or toward vent stack.
- O. Install cast-iron soil piping according to CISPI's "Cast Iron Soil Pipe and Fittings Handbook," Chapter IV, "Installation of Cast Iron Soil Pipe and Fittings."
 - 1. Install encasement on underground piping according to ASTM A 674 or AWWA C105/A 21.5.
- P. Install aboveground copper tubing according to CDA's "Copper Tube Handbook."
- Q. Install engineered soil and waste drainage and vent piping systems as follows:
 - 1. Combination Waste and Vent: Comply with standards of authorities having jurisdiction.
- R. Install copper, force-main tubing according to CDA's "Copper Tube Handbook."
- S. Install force mains at elevations indicated.
- T. Plumbing Specialties:
 - 1. Install cleanouts at grade and extend to where building sanitary drains connect to building sanitary sewers in sanitary drainage gravity-flow piping. Install cleanout fitting with closure plug inside the building in sanitary drainage force-main piping. Comply with requirements for cleanouts specified in Section 221319 "Sanitary Waste Piping Specialties."
 - 2. Install drains in sanitary drainage gravity-flow piping. Comply with requirements for drains specified in Section 221319 "Sanitary Waste Piping Specialties."
- U. Do not enclose, cover, or put piping into operation until it is inspected and approved by authorities having jurisdiction.
- V. Install sleeves for piping penetrations of walls, ceilings, and floors. Comply with requirements for sleeves specified in Section 220517 "Sleeves and Sleeve Seals for Plumbing Piping."
- W. Install sleeve seals for piping penetrations of concrete walls and slabs. Comply with requirements for sleeve seals specified in Section 220517 "Sleeves and Sleeve Seals for Plumbing Piping."
- X. Install escutcheons for piping penetrations of walls, ceilings, and floors. Comply with requirements for escutcheons specified in Section 220518 "Escutcheons for Plumbing Piping."

3.3 JOINT CONSTRUCTION

- A. Join hub-and-spigot, cast-iron soil piping with gasket joints according to CISPI's "Cast Iron Soil Pipe and Fittings Handbook" for compression joints.
- B. Join hub-and-spigot, cast-iron soil piping with calked joints according to CISPI's "Cast Iron Soil Pipe and Fittings Handbook" for lead-and-oakum calked joints.

Weedsport Addition to Maintenance Section and Roof Replacement, MP 304.2

- C. Join hubless, cast-iron soil piping according to CISPI 310 and CISPI's "Cast Iron Soil Pipe and Fittings Handbook" for hubless-piping coupling joints.
- D. Join copper tube and fittings with soldered joints according to ASTM B 828. Use ASTM B 813, water-flushable, lead-free flux and ASTM B 32, lead-free-alloy solder.

3.4 SPECIALTY PIPE FITTING INSTALLATION

- A. Transition Couplings:
 - 1. Install transition couplings at joints of piping with small differences in OD's.
 - 2. In Drainage Piping: Shielded, nonpressure transition couplings.
 - 3. In Aboveground Force Main Piping: Fitting-type transition couplings.
 - 4. In Underground Force Main Piping:
 - a. NPS 1-1/2 and Smaller: Fitting-type transition couplings.
 - b. NPS 2 and Larger: Pressure transition couplings.
- B. Dielectric Fittings:
 - 1. Install dielectric fittings in piping at connections of dissimilar metal piping and tubing.
 - 2. Dielectric Fittings for NPS 2 and Smaller: Use dielectric nipples or unions.
 - 3. Dielectric Fittings for NPS 2-1/2 to NPS 4: Use dielectric flange kits.
 - 4. Dielectric Fittings for NPS 5 and Larger: Use dielectric flange kits.

3.5 VALVE INSTALLATION

- A. General valve installation requirements are specified in Section 220523 "General-Duty Valves for Plumbing Piping."
- B. Shutoff Valves:
 - 1. Install shutoff valve on each sewage pump discharge.
 - 2. Install gate or full-port ball valve for piping NPS 2 and smaller.
 - 3. Install gate valve for piping NPS 2-1/2 and larger.
- C. Check Valves: Install swing check valve, between pump and shutoff valve, on each sewage pump discharge.

3.6 HANGER AND SUPPORT INSTALLATION

- A. Comply with requirements for seismic-restraint devices.
- B. Comply with requirements for pipe hanger and support devices and installation specified in Section 220529 "Hangers and Supports for Plumbing Piping and Equipment."
 - 1. Install carbon-steel pipe hangers for horizontal piping in noncorrosive environments.
 - 2. Install carbon-steel pipe support clamps for vertical piping in noncorrosive environments.
 - 3. Vertical Piping: MSS Type 8 or Type 42, clamps.
 - 4. Install individual, straight, horizontal piping runs:
 - a. 100 Feet and Less: MSS Type 1, adjustable, steel clevis hangers.
 - b. Longer Than 100 Feet: MSS Type 43, adjustable roller hangers.
 - c. Longer Than 100 Feet if Indicated: MSS Type 49, spring cushion rolls.
 - 5. Multiple, Straight, Horizontal Piping Runs 100 Feet or Longer: MSS Type 44, pipe rolls. Support pipe rolls on trapeze.
 - 6. Base of Vertical Piping: MSS Type 52, spring hangers.
- C. Support horizontal piping and tubing within 12 inches of each fitting and coupling.
- D. Support vertical piping and tubing at base and at each floor.

Weedsport Addition to Maintenance Section and Roof Replacement, MP 304.2

- E. Rod diameter may be reduced one size for double-rod hangers, with 3/8-inch minimum rods.
- F. Install hangers for cast-iron soil piping with the following maximum horizontal spacing and minimum rod diameters:
 - 1. NPS 1-1/2 and NPS 2: 60 inches with 3/8-inch rod.
 - 2. NPS 3: 60 inches with 1/2-inch rod.
 - 3. NPS 4 and NPS 5: 60 inches with 5/8-inch rod.
 - 4. NPS 6 and NPS 8: 60 inches with 3/4-inch rod.
 - 5. NPS 10 and NPS 12: 60 inches with 7/8-inch rod.
 - 6. Spacing for 10-foot lengths may be increased to 10 feet. Spacing for fittings is limited to 60 inches.
- G. Install supports for vertical cast-iron soil piping every 15 feet.
- H. Install hangers for copper tubing with the following maximum horizontal spacing and minimum rod diameters:
 - 1. NPS 1-1/4: 72 inches with 3/8-inch rod.
 - 2. NPS 1-1/2 and NPS 2: 96 inches with 3/8-inch rod.
 - 3. NPS 2-1/2: 108 inches with 1/2-inch rod.
 - 4. NPS 3 and NPS 5: 10 feet with 1/2-inch rod.
 - 5. NPS 6: 10 feet with 5/8-inch rod.
 - 6. NPS 8: 10 feet with 3/4-inch rod.
- I. Install supports for vertical copper tubing every 10 feet.
- J. Support piping and tubing not listed above according to MSS SP-69 and manufacturer's written instructions.

3.7 CONNECTIONS

- A. Drawings indicate general arrangement of piping, fittings, and specialties.
- B. Connect soil and waste piping to exterior sanitary sewerage piping. Use transition fitting to join dissimilar piping materials.
- C. Connect drainage and vent piping to the following:
 - 1. Plumbing Fixtures: Connect drainage piping in sizes indicated, but not smaller than required by plumbing code.
 - 2. Plumbing Fixtures and Equipment: Connect atmospheric vent piping in sizes indicated, but not smaller than required by authorities having jurisdiction.
 - 3. Plumbing Specialties: Connect drainage and vent piping in sizes indicated, but not smaller than required by plumbing code.
 - 4. Install test tees (wall cleanouts) in conductors near floor and floor cleanouts with cover flush with floor.
 - 5. Comply with requirements for cleanouts and drains specified in Section 221319 "Sanitary Waste Piping Specialties."
 - 6. Equipment: Connect drainage piping as indicated. Provide shutoff valve if indicated and union for each connection. Use flanges instead of unions for connections NPS 2-1/2 and larger.
- D. Connect force-main piping to the following:
 - 1. Sewage Pump: To sewage pump discharge.
- E. Where installing piping adjacent to equipment, allow space for service and maintenance of equipment.

Weedsport Addition to Maintenance Section and Roof Replacement, MP 304.2

- F. Make connections according to the following unless otherwise indicated:
1. Install unions, in piping NPS 2 and smaller, adjacent to each valve and at final connection to each piece of equipment.
 2. Install flanges, in piping NPS 2-1/2 and larger, adjacent to flanged valves and at final connection to each piece of equipment.

3.8 IDENTIFICATION

- A. Identify exposed sanitary waste and vent piping.

3.9 FIELD QUALITY CONTROL

- A. During installation, notify authorities having jurisdiction at least 24 hours before inspection must be made. Perform tests specified below in presence of authorities having jurisdiction.
1. Roughing-in Inspection: Arrange for inspection of piping before concealing or closing-in after roughing-in and before setting fixtures.
 2. Final Inspection: Arrange for final inspection by authorities having jurisdiction to observe tests specified below and to ensure compliance with requirements.
- B. Reinspection: If authorities having jurisdiction find that piping will not pass test or inspection, make required corrections and arrange for reinspection.
- C. Test sanitary drainage and vent piping according to procedures of authorities having jurisdiction or, in absence of published procedures, as follows:
1. Test for leaks and defects in new piping and parts of existing piping that have been altered, extended, or repaired. If testing is performed in segments, submit separate report for each test, complete with diagram of portion of piping tested.
 2. Leave uncovered and unconcealed new, altered, extended, or replaced drainage and vent piping until it has been tested and approved. Expose work that was covered or concealed before it was tested.
 3. Roughing-in Plumbing Test Procedure: Test drainage and vent piping except outside leaders on completion of roughing-in. Close openings in piping system and fill with water to point of overflow, but not less than 10-foot head of water. From 15 minutes before inspection starts to completion of inspection, water level must not drop. Inspect joints for leaks.
 4. Finished Plumbing Test Procedure: After plumbing fixtures have been set and traps filled with water, test connections and prove they are gastight and watertight. Plug vent-stack openings on roof and building drains where they leave building. Introduce air into piping system equal to pressure of 1-inch wg. Use U-tube or manometer inserted in trap of water closet to measure this pressure. Air pressure must remain constant without introducing additional air throughout period of inspection. Inspect plumbing fixture connections for gas and water leaks.
 5. Repair leaks and defects with new materials and retest piping, or portion thereof, until satisfactory results are obtained.
 6. Prepare reports for tests and required corrective action.
- D. Test force-main piping according to procedures of authorities having jurisdiction or, in absence of published procedures, as follows:
1. Leave uncovered and unconcealed new, altered, extended, or replaced force-main piping until it has been tested and approved. Expose work that was covered or concealed before it was tested.
 2. Cap and subject piping to static-water pressure of 50 psig above operating pressure, without exceeding pressure rating of piping system materials. Isolate test source and

Weedsport Addition to Maintenance Section and Roof Replacement, MP 304.2

allow to stand for four hours. Leaks and loss in test pressure constitute defects that must be repaired.

3. Repair leaks and defects with new materials and retest piping, or portion thereof, until satisfactory results are obtained.
 4. Prepare reports for tests and required corrective action.
- E. Reports: Prepare inspection and test reports and have them signed by authorities having jurisdiction. Submit all reports to Architect.

3.10 CLEANING AND PROTECTION

- A. Clean interior of piping. Remove dirt and debris as work progresses.
- B. Protect drains during remainder of construction period to avoid clogging with dirt and debris and to prevent damage from traffic and construction work.
- C. Place plugs in ends of uncompleted piping at end of day and when work stops.

3.11 PIPING SCHEDULE

- A. Flanges and unions may be used on aboveground pressure piping unless otherwise indicated.
- B. Aboveground, soil and waste piping NPS 4 and smaller shall be the following:
 1. Service class, cast-iron soil pipe and fittings; gaskets; and gasketed joints.
 2. Hubless, cast-iron soil pipe and fittings; heavy-duty hubless-piping couplings; and coupled joints.
 3. Copper DWV tube, copper drainage fittings, and soldered joints.
 4. Dissimilar Pipe-Material Couplings: Shielded, nonpressure transition couplings.
- C. Aboveground, soil and waste piping NPS 5 and larger shall be the following:
 1. Service class, cast-iron soil pipe and fittings; gaskets; and gasketed joints.
 2. Hubless, cast-iron soil pipe and fittings; heavy-duty hubless-piping couplings; and coupled joints.
 3. Dissimilar Pipe-Material Couplings: Shielded, nonpressure transition couplings.
- D. Aboveground, vent piping NPS 4 and smaller shall be the following:
 1. Service class, cast-iron soil pipe and fittings; gaskets; and gasketed joints.
 2. Hubless, cast-iron soil pipe and fittings; CISPI hubless-piping couplings; and coupled joints.
 3. Copper DWV tube, copper drainage fittings, and soldered joints.
 4. Dissimilar Pipe-Material Couplings: Shielded, nonpressure transition couplings.
- E. Underground, soil, waste, and vent piping NPS 4 and smaller shall be the following:
 1. Service class, cast-iron soil piping; gaskets; and gasketed joints.
 2. Hubless, cast-iron soil pipe and fittings; heavy-duty hubless-piping couplings; and coupled joints.
 3. Dissimilar Pipe-Material Couplings: Shielded, nonpressure transition couplings.
- F. Underground, soil and waste piping NPS 5 and larger shall be the following:
 1. Service class, cast-iron soil piping; gaskets; and gasketed joints.
 2. Hubless, cast-iron soil pipe and fittings; heavy-duty hubless-piping couplings; coupled joints.
 3. Dissimilar Pipe-Material Couplings: Shielded, nonpressure transition couplings.
- G. Aboveground sanitary-sewage force mains NPS 1-1/2 and NPS 2 shall be the following:
 1. Hard copper tube, Type L; copper pressure fittings; and soldered joints.

Weedsport Addition to Maintenance Section and Roof Replacement, MP 304.2

2. Galvanized-steel pipe, pressure fittings, and threaded joints.

END OF SECTION 221316

SECTION 221319 - SANITARY WASTE PIPING SPECIALTIES

PART 1 - GENERAL

1.1 RELATED DOCUMENTS

- A. Drawings and general provisions of the Contract, including General and Supplementary Conditions and Division 01 Specification Sections, apply to this Section.

1.2 SUMMARY

- A. Section Includes:
1. Cleanouts.
 2. Floor drains.
 3. Air-admittance valves.
 4. Roof flashing assemblies.
 5. Through-penetration firestop assemblies.
 6. Miscellaneous sanitary drainage piping specialties.
 7. Flashing materials.

1.3 INFORMATIONAL SUBMITTALS

- A. Field quality-control test reports.

1.4 CLOSEOUT SUBMITTALS

- A. Operation and Maintenance Data: For drainage piping specialties to include in emergency, operation, and maintenance manuals.

1.5 QUALITY ASSURANCE

- A. Drainage piping specialties shall bear label, stamp, or other markings of specified testing agency.
- B. Electrical Components, Devices, and Accessories: Listed and labeled as defined in NFPA 70, Article 100, by a testing agency acceptable to authorities having jurisdiction, and marked for intended use.

1.6 COORDINATION

- A. Coordinate size and location of roof penetrations.

PART 2 - PRODUCTS

2.1 CLEANOUTS

- A. Exposed Metal Cleanouts CO:
1. Available Manufacturers: Subject to compliance with requirements, manufacturers offering products that may be incorporated into the Work include, but are not limited to, the following:
 - a. Josam Company; Josam Div.
 - b. MIFAB, Inc.
 - c. Smith, Jay R. Mfg. Co.; Division of Smith Industries, Inc.
 - d. Tyler Pipe; Wade Div.
 - e. Watts Drainage Products Inc.

Weedsport Addition to Maintenance Section and Roof Replacement, MP 304.2

- f. Zurn Plumbing Products Group; Specification Drainage Operation.
 2. Standard: ASME A112.36.2M for cast iron for cleanout test tee.
 3. Size: Same as connected drainage piping
 4. Body Material: Hubless, cast-iron soil pipe test tee as required to match connected piping.
 5. Closure: Countersunk or raised-head, brass plug.
 6. Closure Plug Size: Same as or not more than one size smaller than cleanout size.
 7. Closure: Stainless-steel plug with seal.
- B. Metal Floor Cleanouts FCO:
1. Available Manufacturers: Subject to compliance with requirements, manufacturers offering products that may be incorporated into the Work include, but are not limited to, the following:
 - a. Josam Company; Josam Div.
 - b. Sioux Chief Manufacturing Company, Inc.
 - c. Smith, Jay R. Mfg. Co.; Division of Smith Industries, Inc.
 - d. Tyler Pipe; Wade Div.
 - e. Watts Drainage Products Inc.
 - f. Zurn Plumbing Products Group; Specification Drainage Operation.
 2. Standard: ASME A112.36.2M for cast-iron soil pipe with cast-iron ferrule threaded, adjustable housing cleanout.
 3. Size: Same as connected branch.
 4. Type: Threaded, adjustable housing.
 5. Body or Ferrule: Cast iron.
 6. Clamping Device: Required.
 7. Outlet Connection: Spigot.
 8. Closure: Brass plug with straight threads and gasket.
 9. Adjustable Housing Material: Cast iron with set-screws or other device.
 10. Frame and Cover Material and Finish: Nickel-bronze, copper alloy.
 11. Frame and Cover Shape: Round.
 12. Top Loading Classification: Medium Duty.
 13. Riser: ASTM A 74, Service class, cast-iron drainage pipe fitting and riser to cleanout.
 14. Standard: ASME A112.3.1.
 15. Size: Same as connected branch.
- C. Cast-Iron Wall Cleanouts WCO:
1. Available Manufacturers: Subject to compliance with requirements, manufacturers offering products that may be incorporated into the Work include, but are not limited to, the following:
 - a. Josam Company; Josam Div.
 - b. MIFAB, Inc.
 - c. Smith, Jay R. Mfg. Co.; d of Smith Industries, Inc.
 - d. Tyler Pipe; Wade Div.
 - e. Watts Drainage Products Inc.
 - f. Zurn Plumbing Products Group; Specification Drainage Operation.
 2. Standard: ASME A112.36.2M. Include wall access.
 3. Size: Same as connected drainage piping.
 4. Body: Hub-and-spigot, cast-iron soil pipe T-branch or Hubless, cast-iron soil pipe test tee as required to match connected piping.
 5. Closure: Countersunk, brass plug.
 6. Closure Plug Size: Same as or not more than one size smaller than cleanout size.

Weedsport Addition to Maintenance Section and Roof Replacement, MP 304.2

7. Wall Access: Round, flat, chrome-plated brass or stainless-steel cover plate with screw.

2.2 FLOOR DRAINS

- A. Cast-Iron Floor Drains **FD-1**, general area drains, shower floor, etc.:
 1. Available Manufacturers: Subject to compliance with requirements, manufacturers offering products that may be incorporated into the Work include, but are not limited to, the following:
 - a. Josam Company; Josam Div.
 - b. MIFAB, Inc.
 - c. Smith, Jay R. Mfg. Co.; Division of Smith Industries, Inc.
 - d. Tyler Pipe; Wade Div.
 - e. Watts Drainage Products Inc.
 - f. Zurn Plumbing; Specification Drainage Operation. Equal to Z415B
 2. Standard: ASME A112.6.3.
 3. Pattern: Area Floor drain.
 4. Body Material: Gray iron.
 5. Seepage Flange: Not required.
 6. Clamping Device: Required.
 7. Outlet: Bottom.
 8. Sediment Bucket: Not required.
 9. Top or Strainer Material: Nickel bronze.
 10. Top of Body and Strainer Finish: Nickel bronze.
 11. Top Shape: Round.
 12. Dimensions of Top or Strainer: 8"
 13. Top Loading Classification: Medium Duty.
 14. Funnel: Not required, except if accepting indirect waste discharge (i.e Ice machine) then add funnel.
 15. Trap Material: Cast iron.
 16. Trap Pattern: Deep-seal P-trap.
 17. Trap Features: Trap-seal primer valve drain connection.

2.3 AIR-ADMITTANCE VALVES

- A. Fixture Air-Admittance Valves:
 1. Available Manufacturers: Subject to compliance with requirements, manufacturers offering products that may be incorporated into the Work include, but are not limited to, the following:
 - a. Oatey.
 - b. ProSet Systems Inc.
 - c. RectorSeal.
 - d. Studor, Inc.
 2. Standard: ASSE 1051, Type A for single fixture or Type B for branch piping.
 3. Housing: Plastic.
 4. Operation: Mechanical sealing diaphragm.
 5. Size: Same as connected fixture or branch vent piping.

2.4 ROOF FLASHING ASSEMBLIES

- A. Roof Flashing Assemblies:

Weedsport Addition to Maintenance Section and Roof Replacement, MP 304.2

1. Available Manufacturers: Subject to compliance with requirements, manufacturers offering products that may be incorporated into the Work include, but are not limited to, the following:
 - a. Acorn Engineering Company; Elmdor/Stoneman Div.
 - b. Thaler Metal Industries Ltd.
- B. Description: Manufactured assembly made of 4.0-lb/sq. ft., 0.0625-inch- thick, lead flashing collar and skirt extending at least 6 inches from pipe, with galvanized-steel boot reinforcement and counterflashing fitting.
 1. Open-Top Vent Cap: Without cap.
 2. Low-Silhouette Vent Cap: With vandal-proof vent cap.
 3. Extended Vent Cap: With field-installed, vandal-proof vent cap.

2.5 THROUGH-PENETRATION FIRESTOP ASSEMBLIES

- A. Through-Penetration Firestop Assemblies:
 1. Available Manufacturers: Subject to compliance with requirements, manufacturers offering products that may be incorporated into the Work include, but are not limited to, the following:
 - a. ProSet Systems Inc.
 2. Standard: UL 1479 assembly of sleeve and stack fitting with firestopping plug.
 3. Size: Same as connected soil, waste, or vent stack.
 4. Sleeve: Molded PVC plastic, of length to match slab thickness and with integral nailing flange on one end for installation in cast-in-place concrete slabs.
 5. Stack Fitting: ASTM A 48/A 48M, gray-iron, hubless-pattern, wye branch with neoprene O-ring at base and gray-iron plug in thermal-release harness. Include PVC protective cap for plug.
 6. Special Coating: Corrosion resistant on interior of fittings.

2.6 MISCELLANEOUS SANITARY DRAINAGE PIPING SPECIALTIES

- A. Deep-Seal Traps:
 1. Description: Cast-iron or bronze casting, with inlet and outlet matching connected piping and cleanout trap-seal primer valve connection.
 2. Size: Same as connected waste piping.
 - a. NPS 2: 4-inch- minimum water seal.
 - b. NPS 2-1/2 and Larger: 5-inch- minimum water seal.
- B. Floor-Drain, Trap-Seal Primer Fittings:
 1. Description: Cast iron, with threaded inlet and threaded or spigot outlet, and trap-seal primer valve connection.
 2. Size: Same as floor drain outlet with NPS 1/2 side inlet.
- C. Air-Gap Fittings:
 1. Standard: ASME A112.1.2, for fitting designed to ensure fixed, positive air gap between installed inlet and outlet piping.
 2. Body: Bronze or cast iron.
 3. Inlet: Opening in top of body.
 4. Outlet: Larger than inlet.
 5. Size: Same as connected waste piping and with inlet large enough for associated indirect waste piping.
- D. Sleeve Flashing Device:

Weedsport Addition to Maintenance Section and Roof Replacement, MP 304.2

1. Description: Manufactured, cast-iron fitting, with clamping device, that forms sleeve for pipe floor penetrations of floor membrane. Include galvanized-steel pipe extension in top of fitting that will extend 2 inches above finished floor and galvanized-steel pipe extension in bottom of fitting that will extend through floor slab.
 2. Size: As required for close fit to riser or stack piping.
- E. Stack Flashing Fittings:
1. Description: Counterflashing-type, cast-iron fitting, with bottom recess for terminating roof membrane, and with threaded or hub top for extending vent pipe.
 2. Size: Same as connected stack vent or vent stack.
- F. Vent Caps:
1. Description: Cast-iron body with threaded or hub inlet and vandal-proof design. Include vented hood and setscrews to secure to vent pipe.
 2. Size: Same as connected stack vent or vent stack.
- G. Frost-Resistant Vent Terminals:
1. Description: Manufactured or shop-fabricated assembly constructed of copper, lead-coated copper, or galvanized steel.
 2. Design: To provide 1-inch enclosed air space between outside of pipe and inside of flashing collar extension, with counterflashing.
- H. Expansion Joints:
1. Standard: ASME A112.21.2M.
 2. Body: Cast iron with bronze sleeve, packing, and gland.
 3. End Connections: Matching connected piping.
 4. Size: Same as connected soil, waste, or vent piping.

2.7 FLASHING MATERIALS

- A. Lead Sheet: ASTM B 749, Type L51121, copper bearing, with the following minimum weights and thicknesses, unless otherwise indicated:
1. General Use: 4.0-lb/sq. ft., 0.0625-inch thickness.
 2. Vent Pipe Flashing: 3.0-lb/sq. ft., 0.0469-inch thickness.
 3. Burning: 6-lb/sq. ft., 0.0938-inch thickness.
- B. Copper Sheet: ASTM B 152/B 152M, of the following minimum weights and thicknesses, unless otherwise indicated:
1. General Applications: 12 oz./sq. ft..
 2. Vent Pipe Flashing: 8 oz./sq. ft..
- C. Fasteners: Metal compatible with material and substrate being fastened.
- D. Metal Accessories: Sheet metal strips, clamps, anchoring devices, and similar accessory units required for installation; matching or compatible with material being installed.
- E. Solder: ASTM B 32, lead-free alloy.
- F. Bituminous Coating: SSPC-Paint 12, solvent-type, bituminous mastic.

PART 3 - EXECUTION**3.1 INSTALLATION**

- A. Install cleanouts in aboveground piping and building drain piping according to the following, unless otherwise indicated:

Weedsport Addition to Maintenance Section and Roof Replacement, MP 304.2

1. Size same as drainage piping up to NPS 4. Use NPS 4 for larger drainage piping unless larger cleanout is indicated.
 2. Locate at each change in direction of piping greater than 45 degrees.
 3. Locate at minimum intervals of 50 feet for piping NPS 4 and smaller and 100 feet for larger piping.
 4. Locate at base of each vertical soil and waste stack.
- B. For floor cleanouts for piping below floors, install cleanout deck plates with top flush with finished floor.
- C. For cleanouts located in concealed piping, install cleanout wall access covers, of types indicated, with frame and cover flush with finished wall.
- D. Install floor drains and floor sinks at low points of surface areas to be drained. Set grates of drains flush with finished floor, unless otherwise indicated.
1. Position floor drains for easy access and maintenance.
 2. Set floor drains below elevation of surrounding finished floor to allow floor drainage. Set with grates depressed according to the following drainage area radii:
 - a. Radius, 30 Inches or Less: Equivalent to 1 percent slope, but not less than 1/4-inch total depression.
 - b. Radius, 30 to 60 Inches: Equivalent to 1 percent slope.
 - c. Radius, 60 Inches or Larger: Equivalent to 1 percent slope, but not greater than 1-inch total depression.
 3. Install floor-drain flashing collar or flange so no leakage occurs between drain and adjoining flooring. Maintain integrity of waterproof membranes where penetrated.
 4. Install individual traps for floor drains connected to sanitary building drain, unless otherwise indicated.
- E. Install fixture air-admittance valves on fixture drain piping, only where indicated on plans as acceptable.
- F. Install roof flashing assemblies on sanitary stack vents and vent stacks that extend through roof.
- G. Install flashing fittings on sanitary stack vents and vent stacks that extend through roof.
- H. Install deep-seal traps on floor drains and other waste outlets, if indicated.
- I. Install floor-drain, trap-seal primer fittings on inlet to floor drains that require trap-seal primer connection.
1. Exception: Fitting may be omitted if trap has trap-seal primer connection.
 2. Size: Same as floor drain inlet.
- J. Install air-gap fittings on draining-type backflow preventers and on indirect-waste piping discharge into sanitary drainage system.
- K. Install sleeve flashing device with each riser and stack passing through floors with waterproof membrane.
- L. Install vent caps on each vent pipe passing through roof.
- M. Install frost-resistant vent terminals on each vent pipe passing through roof. Maintain 1-inch clearance between vent pipe and roof substrate.
- N. Install expansion joints on vertical stacks and conductors. Position expansion joints for easy access and maintenance.
- O. Install frost-proof vent caps on each vent pipe passing through roof. Maintain 1-inch clearance between vent pipe and roof substrate.

Weedsport Addition to Maintenance Section and Roof Replacement, MP 304.2

- P. Install solids interceptors with cleanout immediately downstream from interceptors that do not have integral cleanout on outlet. Install trap on interceptors that do not have integral trap and are connected to sanitary drainage and vent systems.
- Q. Install traps on plumbing specialty drain outlets. Omit traps on indirect wastes unless trap is indicated.

3.2 CONNECTIONS

- A. Comply with requirements in Section 221316 "Sanitary Waste and Vent Piping" for piping installation requirements. Drawings indicate general arrangement of piping, fittings, and specialties.
- B. Install piping adjacent to equipment to allow service and maintenance.
- C. Ground equipment according to Section 260526 "Grounding and Bonding for Electrical Systems."
- D. Connect wiring according to Section 260519 "Low-Voltage Electrical Power Conductors and Cables."

3.3 FLASHING INSTALLATION

- A. Fabricate flashing from single piece unless large pans, sumps, or other drainage shapes are required. Join flashing according to the following if required:
 1. Lead Sheets: Burn joints of lead sheets 6.0-lb/sq. ft., 0.0938-inch thickness or thicker. Solder joints of lead sheets 4.0-lb/sq. ft., 0.0625-inch thickness or thinner.
 2. Copper Sheets: Solder joints of copper sheets.
- B. Install sheet flashing on pipes, sleeves, and specialties passing through or embedded in floors and roofs with waterproof membrane.
 1. Pipe Flashing: Sleeve type, matching pipe size, with minimum length of 10 inches, and skirt or flange extending at least 8 inches around pipe.
 2. Sleeve Flashing: Flat sheet, with skirt or flange extending at least 8 inches around sleeve.
 3. Embedded Specialty Flashing: Flat sheet, with skirt or flange extending at least 8 inches around specialty.
- C. Set flashing on floors and roofs in solid coating of bituminous cement.
- D. Secure flashing into sleeve and specialty clamping ring or device.
- E. Install flashing for piping passing through roofs with counterflashing or commercially made flashing fittings, according to Section 076200 "Sheet Metal Flashing and Trim."
- F. Extend flashing up vent pipe passing through roofs and turn down into pipe, or secure flashing into cast-iron sleeve having calking recess.
- G. Fabricate and install flashing and pans, sumps, and other drainage shapes.

3.4 FIELD QUALITY CONTROL

- A. Tests and Inspections:
 1. Leak Test: After installation, charge system and test for leaks. Repair leaks and retest until no leaks exist.
 2. Test and adjust controls and safeties. Replace damaged and malfunctioning controls and equipment.

Weedsport Addition to Maintenance Section and Roof Replacement, MP 304.2

3.5 PROTECTION

- A. Protect drains during remainder of construction period to avoid clogging with dirt or debris and to prevent damage from traffic or construction work.
- B. Place plugs in ends of uncompleted piping at end of each day or when work stops.

END OF SECTION 221319

SECTION 221413 - FACILITY STORM DRAINAGE PIPING

PART 1 - GENERAL

1.1 RELATED DOCUMENTS

- A. Drawings and general provisions of the Contract, including General and Supplementary Conditions and Division 01 Specification Sections, apply to this Section.

1.2 SUMMARY

- A. Section Includes:
1. Pipe, tube, and fittings.
 2. Specialty pipe fittings.
 3. Encasement for underground metal piping.

1.3 PERFORMANCE REQUIREMENTS

- A. Components and installation shall be capable of withstanding the following minimum working pressure unless otherwise indicated:
1. Storm Drainage Piping: 10-foot head of water.
- B. Seismic Performance: Storm drainage piping and support and installation shall withstand the effects of earthquake motions determined according to ASCE/SEI 7.
1. Storm piping directly over Operating rooms shall be supported per Seismic requirements. Importance Factor 1.5.
 2. All other storm piping: Importance Factor 1.0 (no seismic support required).

1.4 ACTION SUBMITTALS

- A. Product Data: For each type of product indicated.

1.5 INFORMATIONAL SUBMITTALS

- A. Seismic Qualification Certificates: For storm drainage piping, accessories, and components, from manufacturer.
1. Basis for Certification: Indicate whether withstand certification is based on actual test of assembled components or on calculation.
 2. Detailed description of equipment anchorage devices on which the certification is based and their installation requirements.
- B. Field quality-control reports.

1.6 QUALITY ASSURANCE

- A. Piping materials shall bear label, stamp, or other markings of specified testing agency.

1.7 PROJECT CONDITIONS

- A. Interruption of Existing Storm-Drainage Service: Do not interrupt service to facilities occupied by Owner or others unless permitted under the following conditions and then only after arranging to provide temporary service according to requirements indicated:
1. Notify Architect, Construction Manager, and Owner no fewer than two days in advance of proposed interruption of storm-drainage service.

Weedsport Addition to Maintenance Section and Roof Replacement, MP 304.2

2. Do not proceed with interruption of storm-drainage service without Owner's written permission.

PART 2 - PRODUCTS

2.1 PIPING MATERIALS

- A. Comply with requirements in "Piping Schedule" Article for applications of pipe, tube, fitting materials, and joining methods for specific services, service locations, and pipe sizes.

2.2 HUB-AND-SPIGOT, CAST-IRON SOIL PIPE AND FITTINGS

- A. Pipe and Fittings: ASTM A 74, Service classes.
- B. Gaskets: ASTM C 564, rubber.
- C. Calking Materials: ASTM B 29, pure lead and oakum or hemp fiber.

2.3 HUBLESS, CAST-IRON SOIL PIPE AND FITTINGS

- A. Pipe and Fittings: ASTM A 888 or CISPI 301.
- B. CISPI, Hubless-Piping Couplings:
 1. Manufacturers: Subject to compliance with requirements, available manufacturers offering products that may be incorporated into the Work include, but are not limited to, the following:
 - a. ANACO-Husky.
 - b. Feroco Inc.
 - c. Mission Rubber Company; a division of MCP Industries, Inc.
 - d. Tyler Pipe.
 2. Standards: ASTM C 1277 and CISPI 310.
 3. Description: Stainless-steel corrugated shield with stainless-steel bands and tightening devices; and ASTM C 564, rubber sleeve with integral, center pipe stop.
- C. Heavy-Duty, Hubless-Piping Couplings:
 1. Manufacturers: Subject to compliance with requirements, available manufacturers offering products that may be incorporated into the Work include, but are not limited to, the following:
 - a. ANACO-Husky.
 - b. Clamp-All Corp.
 - c. Mission Rubber Company; a division of MCP Industries, Inc.
 - d. Tyler Pipe.
 2. Standards: ASTM C 1277 and ASTM C 1540.
 3. Description: Stainless-steel shield with stainless-steel bands and tightening devices; and ASTM C 564, rubber sleeve with integral, center pipe stop.

2.4 PVC PIPE AND FITTINGS

- A. Solid-Wall PVC Pipe: ASTM D 2665, drain, waste, and vent.
- B. Cellular-Core PVC Pipe: ASTM F 891, Schedule 40.
- C. PVC Socket Fittings: ASTM D 2665, made to ASTM D 3311, drain, waste, and vent patterns and to fit Schedule 40 pipe.

Weedsport Addition to Maintenance Section and Roof Replacement, MP 304.2

- D. Adhesive Primer: ASTM F 656.
1. Adhesive primer shall have a VOC content of 550 g/L or less when calculated according to 40 CFR 59, Subpart D (EPA Method 24).
 2. Adhesive primer shall comply with the testing and product requirements of the California Department of Health Services' "Standard Practice for the Testing of Volatile Organic Emissions from Various Sources Using Small-Scale Environmental Chambers."
- E. Solvent Cement: ASTM D 2564.
1. PVC solvent cement shall have a VOC content of 510 g/L or less when calculated according to 40 CFR 59, Subpart D (EPA Method 24).
 2. Solvent cement shall comply with the testing and product requirements of the California Department of Health Services' "Standard Practice for the Testing of Volatile Organic Emissions from Various Sources Using Small-Scale Environmental Chambers."

2.5 SPECIALTY PIPE FITTINGS

- A. Transition Couplings:
1. General Requirements: Fitting or device for joining piping with small differences in OD's or of different materials. Include end connections same size as and compatible with pipes to be joined.
 2. Fitting-Type Transition Couplings: Manufactured piping coupling or specified-piping-system fitting.
 3. Shielded, Nonpressure Transition Couplings:
 - a. Manufacturers: Subject to compliance with requirements, provide products by one of the following] [available manufacturers offering products that may be incorporated into the Work include, but are not limited to, the following:
 - 1) Mission Rubber Company; a division of MCP Industries, Inc.
 - b. Standard: ASTM C 1460.
 - c. Description: Elastomeric or rubber sleeve with full-length, corrosion-resistant outer shield and corrosion-resistant-metal tension band and tightening mechanism on each end.
- B. Dielectric Fittings:
1. General Requirements: Assembly of copper alloy and ferrous materials with separating nonconductive insulating material. Include end connections compatible with pipes to be joined.
 2. Dielectric Unions:
 - a. Manufacturers: Subject to compliance with requirements, available manufacturers offering products that may be incorporated into the Work include, but are not limited to, the following:
 - 1) Capitol Manufacturing Company.
 - 2) Hart Industries International, Inc.
 - 3) Jomar International Ltd.
 - 4) Matco-Norca, Inc.
 - 5) McDonald, A. Y. Mfg. Co.
 - 6) Watts Regulator Co.; a division of Watts Water Technologies, Inc.
 - 7) Wilkins; a Zurn company.
 - b. Description:

Weedsport Addition to Maintenance Section and Roof Replacement, MP 304.2

- 1) Standard: ASSE 1079.
 - 2) Pressure Rating: 150 psig at 180 deg F.
 - 3) End Connections: Solder-joint copper alloy and threaded ferrous.
3. Dielectric Flanges:
- a. Manufacturers: Subject to compliance with requirements, available manufacturers offering products that may be incorporated into the Work include, but are not limited to, the following:
 - 1) Capitol Manufacturing Company.
 - 2) Matco-Norca, Inc.
 - 3) Watts Regulator Co.; a division of Watts Water Technologies, Inc.
 - 4) Wilkins; a Zurn company.
 - b. Description:
 - 1) Standard: ASSE 1079.
 - 2) Factory-fabricated, bolted, companion-flange assembly.
 - 3) Pressure Rating: 150 psig.
 - 4) End Connections: Solder-joint copper alloy and threaded ferrous; threaded solder-joint copper alloy and threaded ferrous.
4. Dielectric-Flange Insulating Kits:
- a. Manufacturers: Subject to compliance with requirements, available manufacturers offering products that may be incorporated into the Work include, but are not limited to, the following:
 - 1) Advance Products & Systems, Inc.
 - 2) Calpico, Inc.
 - 3) Pipeline Seal and Insulator, Inc.
 - b. Description:
 - 1) Nonconducting materials for field assembly of companion flanges.
 - 2) Pressure Rating: 150 psig.
 - 3) Gasket: Neoprene or phenolic.
 - 4) Bolt Sleeves: Phenolic or polyethylene.
 - 5) Washers: Phenolic with steel-backing washers.
5. Dielectric Nipples:
- a. Manufacturers: Subject to compliance with requirements, available manufacturers offering products that may be incorporated into the Work include, but are not limited to, the following:
 - 1) Elster Perfection.
 - 2) Grinnell Mechanical Products.
 - 3) Matco-Norca, Inc.
 - 4) Precision Plumbing Products, Inc.
 - 5) Victaulic Company.
 - b. Description:
 - 1) Electroplated steel nipple complying with ASTM F 1545.
 - 2) Pressure Rating: 300 psig at 225 deg F.
 - 3) End Connections: Male threaded or grooved.
 - 4) Lining: Inert and noncorrosive, propylene.

PART 3 - EXECUTION

3.1 EARTH MOVING

- A. Comply with requirements for excavating, trenching, and backfilling specified in Section 312000 "Earth Moving."

3.2 PIPING INSTALLATION

- A. Drawing plans, schematics, and diagrams indicate general location and arrangement of piping systems. Indicated locations and arrangements were used to size pipe and calculate friction loss, expansion, pump sizing, and other design considerations. Install piping as indicated unless deviations from layout are approved on coordination drawings.
- B. Install piping in concealed locations unless otherwise indicated and except in equipment rooms and service areas.
- C. Install piping indicated to be exposed and piping in equipment rooms and service areas at right angles or parallel to building walls. Diagonal runs are prohibited unless specifically indicated otherwise.
- D. Install piping above accessible ceilings to allow sufficient space for ceiling panel removal.
- E. Install piping to permit valve servicing.
- F. Install piping at indicated slopes.
- G. Install piping free of sags and bends.
- H. Install fittings for changes in direction and branch connections.
- I. Install piping to allow application of insulation.
- J. Install seismic restraints on piping.
- K. Make changes in direction for storm drainage piping using appropriate branches, bends, and long-sweep bends. Do not change direction of flow more than 90 degrees. Use proper size of standard increasers and reducers if pipes of different sizes are connected. Reducing size of drainage piping in direction of flow is prohibited.
- L. Lay buried building storm drainage piping beginning at low point of each system. Install true to grades and alignment indicated, with unbroken continuity of invert. Place hub ends of piping upstream. Install required gaskets according to manufacturer's written instructions for use of lubricants, cements, and other installation requirements. Maintain swab in piping and pull past each joint as completed.
- M. Install storm drainage piping at the following minimum slopes unless otherwise indicated:
 1. Building Storm Drain: 2 percent downward in direction of flow for piping NPS 3 and smaller; 1 percent downward in direction of flow for piping NPS 4 and larger.
 2. Horizontal Storm-Drainage Piping: 2 percent downward in direction of flow.
- N. Install cast-iron soil piping according to CISPI's "Cast Iron Soil Pipe and Fittings Handbook," Chapter IV, "Installation of Cast Iron Soil Pipe and Fittings."
 1. Install encasement on underground piping according to ASTM A 674 or AWWA C105.
- O. Plumbing Specialties:
 1. Install cleanouts at grade and extend to where building storm drains connect to building storm sewers in storm drainage gravity-flow piping. Install cleanout fitting with closure

Weedsport Addition to Maintenance Section and Roof Replacement, MP 304.2

- plug inside the building in storm drainage force-main piping. Comply with requirements for cleanouts specified in Section 221423 "Storm Drainage Piping Specialties."
2. Install drains in storm drainage gravity-flow piping. Comply with requirements for drains specified in Section 221423 "Storm Drainage Piping Specialties."
- P. Do not enclose, cover, or put piping into operation until it is inspected and approved by authorities having jurisdiction.
- Q. Install sleeves for piping penetrations of walls, ceilings, and floors. Comply with requirements for sleeves specified in Section 220517 "Sleeves and Sleeve Seals for Plumbing Piping."
- R. Install sleeve seals for piping penetrations of concrete walls and slabs. Comply with requirements for sleeve seals specified in Section 220517 "Sleeves and Sleeve Seals for Plumbing Piping."
- S. Install escutcheons for piping penetrations of walls, ceilings, and floors. Comply with requirements for escutcheons specified in Section 220518 "Escutcheons for Plumbing Piping."

3.3 JOINT CONSTRUCTION

- A. Hub-and-Spigot, Cast-Iron Soil Piping Gasketed Joints: Join according to CISPI's "Cast Iron Soil Pipe and Fittings Handbook" for compression joints.
- B. Hubless, Cast-Iron Soil Piping Coupled Joints: Join according to CISPI 310 and CISPI's "Cast Iron Soil Pipe and Fittings Handbook" for hubless-piping coupling joints.

3.4 SPECIALTY PIPE FITTING INSTALLATION

- A. Transition Couplings:
1. Install transition couplings at joints of piping with small differences in OD's.
 2. In Drainage Piping: Shielded, nonpressure transition couplings.
 3. In Aboveground Force-Main Piping: Fitting-type transition couplings.
 4. In Underground Force-Main Piping:
 - a. NPS 1-1/2 and Smaller: Fitting-type transition couplings.
 - b. NPS 2 and Larger: Pressure transition couplings.
- B. Dielectric Fittings:
1. Install dielectric fittings in piping at connections of dissimilar metal piping and tubing.
 2. Dielectric Fittings for NPS 2 and Smaller: Use dielectric nipples.
 3. Dielectric Fittings for NPS 2-1/2 to NPS 4: Use dielectric flange kits.
 4. Dielectric Fittings for NPS 5 and Larger: Use dielectric flange kits.

3.5 VALVE INSTALLATION

- A. General valve installation requirements are specified in Section 220523 "General-Duty Valves for Plumbing Piping."

3.6 HANGER AND SUPPORT INSTALLATION

- A. Comply with requirements for seismic-restraint devices.
- B. Comply with requirements for pipe hanger and support devices and installation specified in Section 220529 "Hangers and Supports for Plumbing Piping and Equipment."
1. Install carbon-steel pipe hangers for horizontal piping in noncorrosive environments.
 2. Install carbon-steel pipe support clamps for vertical piping in noncorrosive environments.
 3. Vertical Piping: MSS Type 8 or Type 42, clamps.

Weedsport Addition to Maintenance Section and Roof Replacement, MP 304.2

4. Individual, Straight, Horizontal Piping Runs:
 - a. 100 Feet and Less: MSS Type 1, adjustable, steel clevis hangers.
 - b. Longer Than 100 Feet: MSS Type 43, adjustable roller hangers.
 - c. Longer Than 100 Feet if Indicated: MSS Type 49, spring cushion rolls.
 5. Multiple, Straight, Horizontal Piping Runs 100 Feet or Longer: MSS Type 44, pipe rolls. Support pipe rolls on trapeze.
 6. Base of Vertical Piping: MSS Type 52, spring hangers.
- C. Support horizontal piping and tubing within 12 inches of each fitting, valve, and coupling.
- D. Support vertical piping and tubing at base and at each floor.
- E. Rod diameter may be reduced one size for double-rod hangers, with 3/8-inch minimum rods.
- F. Install hangers for cast-iron soil piping with the following maximum horizontal spacing and minimum rod diameters:
 1. NPS 1-1/2 and NPS 2: 60 inches with 3/8-inch rod.
 2. NPS 3: 60 inches with 1/2-inch rod.
 3. NPS 4 and NPS 5: 60 inches with 5/8-inch rod.
 4. NPS 6 and NPS 8: 60 inches with 3/4-inch rod.
 5. NPS 10 and NPS 12: 60 inches with 7/8-inch rod.
 6. Spacing for 10-foot pipe lengths may be increased to 10 feet. Spacing for fittings is limited to 60 inches.
- G. Install supports for vertical cast-iron soil piping every 15 feet.
- H. Support piping and tubing not listed above according to MSS SP-69 and manufacturer's written instructions.

3.7 CONNECTIONS

- A. Drawings indicate general arrangement of piping, fittings, and specialties.
- B. Connect interior storm drainage piping to exterior storm drainage piping. Use transition fitting to join dissimilar piping materials.
- C. Connect storm drainage piping to roof drains and storm drainage specialties.
 1. Install test tees (wall cleanouts) in conductors near floor, and floor cleanouts with cover flush with floor.
 2. Comply with requirements for cleanouts and drains specified in Section 221423 "Storm Drainage Piping Specialties."
- D. Where installing piping adjacent to equipment, allow space for service and maintenance of equipment.
- E. Make connections according to the following unless otherwise indicated:
 1. Install unions, in piping NPS 2 and smaller, adjacent to each valve and at final connection to each piece of equipment.
 2. Install flanges, in piping NPS 2-1/2 and larger, adjacent to flanged valves and at final connection to each piece of equipment.

3.8 IDENTIFICATION

- A. Identify exposed storm drainage piping. Comply with requirements for identification specified in Section 220553 "Identification for Plumbing Piping and Equipment."

3.9 FIELD QUALITY CONTROL

- A. During installation, notify authorities having jurisdiction at least 24 hours before inspection must be made. Perform tests specified below in presence of authorities having jurisdiction.
 - 1. Roughing-in Inspection: Arrange for inspection of piping before concealing or closing-in after roughing-in.
 - 2. Final Inspection: Arrange for final inspection by authorities having jurisdiction to observe tests specified below and to ensure compliance with requirements.
- B. Reinspection: If authorities having jurisdiction find that piping will not pass test or inspection, make required corrections and arrange for reinspection.
- C. Test storm drainage piping according to procedures of authorities having jurisdiction or, in absence of published procedures, as follows:
 - 1. Test for leaks and defects in new piping and parts of existing piping that have been altered, extended, or repaired. If testing is performed in segments, submit separate report for each test, complete with diagram of portion of piping tested.
 - 2. Leave uncovered and unconcealed new, altered, extended, or replaced storm drainage piping until it has been tested and approved. Expose work that was covered or concealed before it was tested.
 - 3. Test Procedure: Test storm drainage piping on completion of roughing-in. Close openings in piping system and fill with water to point of overflow, but not less than 10-foot head of water. From 15 minutes before inspection starts until completion of inspection, water level must not drop. Inspect joints for leaks.
 - 4. Repair leaks and defects with new materials and retest piping, or portion thereof, until satisfactory results are obtained.
 - 5. Prepare reports for tests and required corrective action.
- D. Reports: Prepare inspection and test reports and have them signed by authorities having jurisdiction. Submit all reports to Architect.

3.10 CLEANING

- A. Clean interior of piping. Remove dirt and debris as work progresses.
- B. Protect drains during remainder of construction period to avoid clogging with dirt and debris and to prevent damage from traffic and construction work.
- C. Place plugs in ends of uncompleted piping at end of day and when work stops.

3.11 PIPING SCHEDULE

- A. Flanges and unions may be used on aboveground pressure piping unless otherwise indicated.
- B. Aboveground storm drainage piping NPS 8 and smaller shall be the following:
 - 1. Service class, cast-iron soil pipe and fittings; gaskets; and gasketed joints.
 - 2. Hubless, cast-iron soil pipe and fittings; heavy-duty, hubless-piping couplings; and coupled joints.
 - 3. Dissimilar Pipe-Material Couplings: Shielded, nonpressure transition couplings.
- C. Underground storm drainage piping NPS 8 and smaller shall be the following:
 - 1. Service class, cast-iron soil pipe and fittings; gaskets; and gasketed joints.
 - 2. Solid-wall PVC pipe, PVC socket fittings, and solvent-cemented joints.
 - 3. Dissimilar Pipe-Material Couplings: Shielded, nonpressure transition couplings.

END OF SECTION 221413

SECTION 221423 - STORM DRAINAGE PIPING SPECIALTIES

PART 1 - GENERAL

1.1 RELATED DOCUMENTS

- A. Drawings and general provisions of the Contract, including General and Supplementary Conditions and Division 01 Specification Sections, apply to this Section.

1.2 SUMMARY

- A. Section Includes:
1. Roof drains.
 2. Miscellaneous storm drainage piping specialties.
 3. Cleanouts.
 4. Through-penetration firestop assemblies.
 5. Flashing materials.

1.3 ACTION SUBMITTALS

- A. Product Data: For each type of product indicated.

1.4 QUALITY ASSURANCE

- A. Drainage piping specialties shall bear label, stamp, or other markings of specified testing agency.

PART 2 - PRODUCTS

2.1 METAL ROOF DRAINS

- A. Cast-Iron, Large-Sump, Primary General-Purpose Roof Drains **RD-1**:
1. Manufacturers: Subject to compliance with requirements, available manufacturers offering products that may be incorporated into the Work include, but are not limited to, the following:
 - a. Josam Company.
 - b. MIFAB, Inc.
 - c. Smith, Jay R. Mfg. Co.
 - d. Tyler Pipe.
 - e. Watts Water Technologies, Inc.
 - f. Zurn Plumbing; Specification Drainage Operation. Equal to Z121
 2. Standard: ASME A112.6.4, for general-purpose roof drains.
 3. Body Material: Cast iron.
 4. Dimension of Body: Nominal 12-inch diameter.
 5. Combination Flashing Ring and Gravel Stop: Required.
 6. Outlet: Bottom.
 7. Extension Collars: Required.
 8. Underdeck Clamp: Required.
 9. Sump Receiver Plate: Required.
 10. Dome Material: Aluminum.

2.2 MISCELLANEOUS STORM DRAINAGE PIPING SPECIALTIES

- A. Downspout Boots:

Weedsport Addition to Maintenance Section and Roof Replacement, MP 304.2

1. Description: Manufactured, ASTM A 48/A 48M, gray-iron casting, with strap or ears for attaching to building; NPS 4 outlet; and shop-applied bituminous coating.
 2. Size: Inlet size to match downspout and NPS 4 outlet.
- B. Conductor Nozzles:
1. Description: Bronze body with threaded inlet and bronze wall flange with mounting holes.
 2. Size: Same as connected conductor.

2.3 CLEANOUTS

- A. Floor Cleanouts FCO:
1. Manufacturers: Subject to compliance with requirements, available manufacturers offering products that may be incorporated into the Work include, but are not limited to, the following:
 - a. Josam Company.
 - b. Smith, Jay R. Mfg. Co.
 - c. Tyler Pipe.
 - d. Watts Water Technologies, Inc.
 - e. Zurn Plumbing Products Group; Specification Drainage Operation.
 2. Standard: ASME A112.36.2M, for adjustable housing cast-iron soil pipe with cast-iron ferrule cleanouts.
 3. Size: Same as connected branch.
 4. Body or Ferrule Material: Cast iron.
 5. Clamping Device: Not required.
 6. Outlet Connection: Spigot.
 7. Closure: Brass plug with straight threads and gasket.
 8. Adjustable Housing Material: Cast iron with threads.
 9. Frame and Cover Material and Finish: Nickel-bronze, copper alloy.
 10. Frame and Cover Shape: Round.
 11. Top-Loading Classification: Medium Duty.
 12. Riser: ASTM A 74, Service class, cast-iron drainage pipe fitting and riser to cleanout.
- B. Test Tees:
1. Manufacturers: Subject to compliance with requirements, available manufacturers offering products that may be incorporated into the Work include, but are not limited to, the following:
 - a. Josam Company.
 - b. MIFAB, Inc.
 - c. Smith, Jay R. Mfg. Co.
 - d. Tyler Pipe.
 - e. Watts Water Technologies, Inc.
 - f. Zurn Plumbing Products Group; Specification Drainage Operation.
 2. Standard: ASME A112.36.2M and ASTM A 74, ASTM A 888, or CISPI 301, for cleanout test tees.
 3. Size: Same as connected drainage piping.
 4. Body Material: Hub-and-spigot, cast-iron soil-pipe T-branch or hubless, cast-iron soil-pipe test tee as required to match connected piping.
 5. Closure Plug: Countersunk, brass.
 6. Closure Plug Size: Same as or not more than one size smaller than cleanout size.
- C. Wall Cleanouts WCO:

Weedsport Addition to Maintenance Section and Roof Replacement, MP 304.2

1. Manufacturers: Subject to compliance with requirements, available manufacturers offering products that may be incorporated into the Work include, but are not limited to, the following:
 - a. Josam Company.
 - b. MIFAB, Inc.
 - c. Smith, Jay R. Mfg. Co.
 - d. Tyler Pipe.
 - e. Watts Water Technologies, Inc.
 - f. Zurn Plumbing Products Group; Specification Drainage Operation.
2. Standard: ASME A112.36.2M, for cleanouts. Include wall access.
3. Size: Same as connected drainage piping.
4. Body Material: Hubless, cast-iron soil-pipe test tee as required to match connected piping.
5. Closure: Countersunk, cast-iron plug.
6. Closure Plug Size: Same as or not more than one size smaller than cleanout size.
7. Wall Access: Round, flat, chrome-plated brass, or stainless-steel cover plate with screw.
8. Wall Access: Round, nickel-bronze, copper-alloy, or stainless-steel wall-installation frame and cover.

2.4 THROUGH-PENETRATION FIRESTOP ASSEMBLIES**A. Through-Penetration Firestop Assemblies:**

1. Manufacturers: Subject to compliance with requirements, available manufacturers offering products that may be incorporated into the Work include, but are not limited to, the following:
 - a. ProSet Systems Inc.
2. Standard: ASTM E 814, for through-penetration firestop assemblies.
3. Certification and Listing: Intertek Testing Service NA for through-penetration firestop assemblies.
4. Size: Same as connected pipe.
5. Sleeve: Molded PVC plastic, of length to match slab thickness and with integral nailing flange on one end for installation in cast-in-place concrete slabs.
6. Stack Fitting: ASTM A 48/A 48M, gray-iron, hubless-pattern, wye branch with neoprene O-ring at base and gray-iron plug in thermal-release harness. Include PVC protective cap for plug.
7. Special Coating: Corrosion resistant on interior of fittings.

2.5 FLASHING MATERIALS

- A. Copper Sheet: ASTM B 152/B 152M, 12 oz./sq. ft.
- B. Zinc-Coated Steel Sheet: ASTM A 653/A 653M, with 0.20 percent copper content and 0.04-inch minimum thickness unless otherwise indicated. Include G90 hot-dip galvanized, mill-phosphatized finish for painting if indicated.
- C. Elastic Membrane Sheet: ASTM D 4068, flexible, chlorinated polyethylene, 40-mil minimum thickness.
- D. Fasteners: Metal compatible with material and substrate being fastened.
- E. Metal Accessories: Sheet metal strips, clamps, anchoring devices, and similar accessory units required for installation; matching or compatible with material being installed.
- F. Solder: ASTM B 32, lead-free alloy.

PART 3 - EXECUTION

3.1 INSTALLATION

- A. Install roof drains at low points of roof areas according to roof membrane manufacturer's written installation instructions.
 - 1. Install flashing collar or flange of roof drain to prevent leakage between drain and adjoining roofing. Maintain integrity of waterproof membranes where penetrated.
 - 2. Install expansion joints, if indicated, in roof drain outlets.
 - 3. Position roof drains for easy access and maintenance.
- B. Install downspout boots at grade with top 12 inches above grade. Secure to building wall.
- C. Install conductor nozzles at exposed bottom of conductors where they spill onto grade.
- D. Install cleanouts in aboveground piping and building drain piping according to the following instructions unless otherwise indicated:
 - 1. Use cleanouts the same size as drainage piping up to NPS 4. Use NPS 4 for larger drainage piping unless larger cleanout is indicated.
 - 2. Locate cleanouts at each change in direction of piping greater than 45 degrees.
 - 3. Locate cleanouts at minimum intervals of 50 feet for piping NPS 4 and smaller and 100 feet for larger piping.
 - 4. Locate cleanouts at base of each vertical soil and waste stack.
- E. For floor cleanouts for piping below floors, install cleanout deck plates with top flush with finished floor.
- F. For cleanouts located in concealed piping, install cleanout wall access covers, of types indicated, with frame and cover flush with finished wall.
- G. Install test tees in vertical conductors and near floor.
- H. Install wall cleanouts in vertical conductors. Install access door in wall if indicated.
- I. Install through-penetration firestop assemblies in plastic conductors at concrete floor penetrations.
- J. Install sleeve flashing device with each conductor passing through floors with waterproof membrane.

3.2 CONNECTIONS

- A. Comply with requirements for piping specified in Section 221413 "Facility Storm Drainage Piping." Drawings indicate general arrangement of piping, fittings, and specialties.

3.3 FLASHING INSTALLATION

- A. Fabricate flashing from single piece of metal unless large pans, sumps, or other drainage shapes are required. Join flashing according to the following if required:
 - 1. Lead Sheets: Burn joints of 6.0-lb/sq. ft. lead sheets, 0.0938-inch thickness or thicker. Solder joints of 4.0-lb/sq. ft. lead sheets, 0.0625-inch thickness or thinner.
 - 2. Copper Sheets: Solder joints of copper sheets.
- B. Install sheet flashing on pipes, sleeves, and specialties passing through or embedded in floors and roofs with waterproof membrane.
 - 1. Pipe Flashing: Sleeve type, matching the pipe size, with a minimum length of 10 inches and with skirt or flange extending at least 8 inches around pipe.

Weedsport Addition to Maintenance Section and Roof Replacement, MP 304.2

2. Sleeve Flashing: Flat sheet, with skirt or flange extending at least 8 inches around sleeve.
 3. Embedded Specialty Flashing: Flat sheet, with skirt or flange extending at least 8 inches around specialty.
- C. Set flashing on floors and roofs in solid coating of bituminous cement.
 - D. Secure flashing into sleeve and specialty clamping ring or device.
 - E. Fabricate and install flashing and pans, sumps, and other drainage shapes.

3.4 PROTECTION

- A. Protect drains during remainder of construction period to avoid clogging with dirt or debris and to prevent damage from traffic or construction work.
- B. Place plugs in ends of uncompleted piping at end of each day or when work stops.

END OF SECTION 221423

SECTION 223400 - FUEL-FIRED, DOMESTIC-WATER HEATERS

PART 1 - GENERAL

1.1 RELATED DOCUMENTS

- A. Drawings and general provisions of the Contract, including General and Supplementary Conditions and Division 01 Specification Sections, apply to this Section.

1.2 SUMMARY

- A. Section Includes:
 - 1. Commercial, gas-fired, high-efficiency, storage, domestic-water heaters.
 - 2. Domestic-water heater accessories.

1.3 ACTION SUBMITTALS

- A. Product Data: For each type and size of domestic-water heater indicated. Include rated capacities, operating characteristics, electrical characteristics, and furnished specialties and accessories.
- B. Shop Drawings:
 - 1. Wiring Diagrams: For power, signal, and control wiring.

1.4 INFORMATIONAL SUBMITTALS

- A. Product Certificates: For each type of commercial, gas-fired, domestic-water heater, from manufacturer.
- B. Domestic-Water Heater Labeling: Certified and labeled by testing agency acceptable to authorities having jurisdiction.
- C. Source quality-control reports.
- D. Field quality-control reports.
- E. Warranty: Sample of special warranty.

1.5 CLOSEOUT SUBMITTALS

- A. Operation and Maintenance Data: For fuel-fired, domestic-water heaters to include in emergency, operation, and maintenance manuals.

1.6 QUALITY ASSURANCE

- A. Electrical Components, Devices, and Accessories: Listed and labeled as defined in NFPA 70, by a qualified testing agency, and marked for intended location and application.
- B. ASHRAE/IESNA Compliance: Fabricate and label fuel-fired, domestic-water heaters to comply with ASHRAE/IESNA 90.1.
- C. ASME Compliance:
 - 1. Where ASME-code construction is indicated, fabricate and label commercial, domestic-water heater storage tanks to comply with ASME Boiler and Pressure Vessel Code: Section VIII, Division 1.

Weedsport Addition to Maintenance Section and Roof Replacement, MP 304.2

2. Where ASME-code construction is indicated, fabricate and label commercial, finned-tube, domestic-water heaters to comply with ASME Boiler and Pressure Vessel Code: Section IV.

- D. NSF Compliance: Fabricate and label equipment components that will be in contact with potable water to comply with NSF 61, "Drinking Water System Components - Health Effects."

1.7 COORDINATION

- A. Coordinate sizes and locations of concrete bases with actual equipment provided.

1.8 WARRANTY

- A. Special Warranty: Manufacturer's standard form in which manufacturer agrees to repair or replace components of fuel-fired, domestic-water heaters that fail in materials or workmanship within specified warranty period.
1. Failures include, but are not limited to, the following:
 - a. Structural failures including storage tank and supports.
 - b. Faulty operation of controls.
 - c. Deterioration of metals, metal finishes, and other materials beyond normal use.
 2. Warranty Periods: From date of Substantial Completion.
 - a. Commercial, Gas-Fired, Storage, Domestic-Water Heaters:
 - 1) Storage Tank: Five years.
 - 2) Controls and Other Components: One year(s).
 - b. Commercial, Finned-Tube, Gas-Fired, Domestic-Water Heaters:
 - 1) Heat Exchanger: Five years.
 - 2) Controls and Other Components: One year(s).
 - 3) Separate Hot-Water Storage Tanks: Five years.
 - c. Gas-Fired, Tankless, Domestic-Water Heaters:
 - 1) Heat Exchanger: Five years.
 - 2) Controls and Other Components: Three years.
 - d. Compression Tanks: Five years.

PART 2 - PRODUCTS

2.1 COMMERCIAL, GAS-Fired, STORAGE, domestic-WATER HEATERS

- A. Commercial, Gas-Fired, High-Efficiency, Storage, Domestic-Water Heaters: **WH-1**
1. Manufacturers: Subject to compliance with requirements, available manufacturers offering products that may be incorporated into the Work include, but are not limited to, the following:
 - a. AERCO International, Inc.
 - b. Bradford White Corporation.
 - c. Heat Transfer Products, Inc.
 - d. Lochinvar Corporation.
 - e. PVI Industries, LLC.
 - f. Raypak
 - g. RBI Water Heaters; a Mestek company.
 - h. Rheem Manufacturing Company.
 - i. Smith, A. O.; a division of A. O. Smith Corporation. BTH-120A
 - j. State Industries.
 2. Standard: ANSI Z21.10.3/CSA 4.3.

Weedsport Addition to Maintenance Section and Roof Replacement, MP 304.2

3. Description: Manufacturer's proprietary design to provide at least 95 percent combustion efficiency at optimum operating conditions.
 4. Storage-Tank Construction: ASME-code steel with 150-psig minimum working-pressure rating.
 - a. Tappings: Factory fabricated of materials compatible with tank. Attach tappings to tank before testing.
 - 1) NPS 2 and Smaller: Threaded ends according to ASME B1.20.1.
 - 2) NPS 2-1/2 and Larger: Flanged ends according to ASME B16.5 for steel and stainless-steel flanges and according to ASME B16.24 for copper and copper-alloy flanges.
 - b. Interior Finish: Comply with NSF 61 barrier materials for potable-water tank linings, including extending finish into and through tank fittings and outlets.
 - c. Lining: [Cement] [Glass] [Nickel plate] complying with NSF 61 barrier materials for potable-water tank linings, including extending lining into and through tank fittings and outlets.
 5. Factory-Installed Storage-Tank Appurtenances:
 - a. Anode Rod: Replaceable magnesium.
 - b. Dip Tube: Required unless cold-water inlet is near bottom of tank.
 - c. Drain Valve: Corrosion-resistant metal complying with ASSE 1005.
 - d. Insulation: Comply with ASHRAE/IESNA 90.1. Surround entire storage tank except connections and controls.
 - e. Jacket: Steel with enameled finish.
 - f. Burner or Heat Exchanger: Comply with UL 795 or approved testing agency requirements for gas-fired, high-efficiency, domestic-water heaters and natural-gas fuel.
 - g. Temperature Control: Adjustable thermostat.
 - h. Safety Controls: Automatic, high-temperature-limit and low-water cutoff devices or systems.
 - i. Combination Temperature-and-Pressure Relief Valves: ANSI Z21.22/CSA 4.4-M. Include one or more relief valves with total relieving capacity at least as great as heat input and include pressure setting less than domestic-water heater working-pressure rating. Select one relief valve with sensing element that extends into storage tank.
 6. Draft Hood: [Draft diverter, complying with ANSI Z21.12].
- B. Capacity and Characteristics:
1. Capacity: 60 gallons.
 2. Recovery: 138 GPH at 100 deg F temperature rise.
 3. Temperature Setting: 140 deg F
 4. Fuel Gas Input: 120,000 BTU/HR.
 5. Electrical Characteristics:
 - a. Volts: 120
 - b. Phase: Single.
 - c. Hertz: 60.
 6. Minimum Vent Diameter: 3 inches.

2.2 DOMESTIC-WATER HEATER ACCESSORIES

- A. Domestic-Water Compression Tanks: **ET-1**

Weedsport Addition to Maintenance Section and Roof Replacement, MP 304.2

1. Manufacturers: Subject to compliance with requirements, available manufacturers offering products that may be incorporated into the Work include, but are not limited to, the following:
 - a. AMTROL Inc. ST-12-C
 - b. Flexcon Industries.
 - c. Honeywell International Inc.
 - d. Pentair Pump Group (The); Myers.
 - e. Smith, A. O. Water Products Co.; a division of A. O. Smith Corporation.
 - f. State Industries.
 - g. Taco, Inc.
 2. Description: Steel, ASME pressure-rated tank constructed with welded joints and factory-installed butyl-rubber diaphragm. Include air precharge to minimum system-operating pressure at tank.
 3. Construction:
 - a. Tappings: Factory-fabricated steel, welded to tank before testing and labeling. Include ASME B1.20.1 pipe thread.
 - b. Interior Finish: Comply with NSF 61 barrier materials for potable-water tank linings, including extending finish into and through tank fittings and outlets.
 - c. Air-Charging Valve: Factory installed.
 4. Capacity and Characteristics:
 - a. Working-Pressure Rating: 150 psig.
 - b. Capacity Acceptable: 5 gallons minimum.
 - c. Air Precharge Pressure: 55 PSI.
- B. Drain Pans: Corrosion-resistant metal with raised edge. Comply with ANSI/CSA LC 3. Include dimensions not less than base of domestic-water heater and include drain outlet not less than NPS 3/4 with ASME B1.20.1 pipe threads or with ASME B1.20.7 garden-hose threads.
- C. Piping-Type Heat Traps: Field-fabricated piping arrangement according to ASHRAE/IESNA 90.1[or ASHRAE 90.2].
- D. Heat-Trap Fittings: ASHRAE 90.2.
- E. Gas Shutoff Valves: ANSI Z21.15/CSA 9.1-M, manually operated. Furnish for installation in piping.
- F. Gas Pressure Regulators: ANSI Z21.18/CSA 6.3, appliance type. Include 1/2-psig pressure rating as required to match gas supply.
- G. Combination Temperature-and-Pressure Relief Valves: Include relieving capacity at least as great as heat input and include pressure setting less than domestic-water heater working-pressure rating. Select relief valves with sensing element that extends into storage tank.
 1. Gas-Fired, Domestic-Water Heaters: ANSI Z21.22/CSA 4.4-M.
- H. Vacuum Relief Valves: ANSI Z21.22/CSA 4.4-M.

2.3 SOURCE QUALITY CONTROL

- A. Factory Tests: Test and inspect assembled domestic-water heaters and storage tanks specified to be ASME-code construction, according to ASME Boiler and Pressure Vessel Code.
- B. Hydrostatically test commercial domestic-water heaters and storage tanks to minimum of one and one-half times pressure rating before shipment.
- C. Domestic-water heaters will be considered defective if they do not pass tests and inspections.

Weedsport Addition to Maintenance Section and Roof Replacement, MP 304.2

- D. Prepare test and inspection reports.

PART 3 - EXECUTION

3.1 DOMESTIC-WATER HEATER INSTALLATION

- A. Commercial, Domestic-Water Heater Mounting: Install commercial domestic-water heaters on concrete base. Comply with requirements for concrete base specified in Div 33.
1. Exception: Omit concrete bases for commercial domestic-water heaters if installation on stand, bracket, suspended platform, or directly on floor is indicated.
 2. Maintain manufacturer's recommended clearances.
 3. Arrange units so controls and devices that require servicing are accessible.
 4. Install dowel rods to connect concrete base to concrete floor. Unless otherwise indicated, install dowel rods on 18-inch centers around the full perimeter of concrete base.
 5. For supported equipment, install epoxy-coated anchor bolts that extend through concrete base and anchor into structural concrete floor.
 6. Place and secure anchorage devices. Use setting drawings, templates, diagrams, instructions, and directions furnished with items to be embedded.
 7. Install anchor bolts to elevations required for proper attachment to supported equipment.
 8. Anchor domestic-water heaters to substrate.
- B. Install domestic-water heaters level and plumb, according to layout drawings, original design, and referenced standards. Maintain manufacturer's recommended clearances. Arrange units so controls and devices needing service are accessible.
1. Install shutoff valves on domestic-water-supply piping to domestic-water heaters and on domestic-hot-water outlet piping. Comply with requirements for shutoff valves specified in Section 220523 "General-Duty Valves for Plumbing Piping."
- C. Install gas-fired, domestic-water heaters according to NFPA 54 and NYS Fuel Gas Code.
1. Install gas shutoff valves on gas supply piping to gas-fired, domestic-water heaters without shutoff valves.
 2. Install gas pressure regulators on gas supplies to gas-fired, domestic-water heaters without gas pressure regulators if gas pressure regulators are required to reduce gas pressure at burner.
 3. Install automatic gas valves on gas supplies to gas-fired, domestic-water heaters if required for operation of safety control.
 4. Comply with requirements for gas shutoff valves, gas pressure regulators, and automatic gas valves specified in Section 221124 "Facility Natural-Gas Piping."
- D. Install combination temperature-and-pressure relief valves in top portion of storage tanks. Use relief valves with sensing elements that extend into tanks. Extend commercial-water-heater relief-valve outlet, with drain piping same as domestic-water piping in continuous downward pitch, and discharge by positive air gap onto closest floor drain.
- E. Install combination temperature-and-pressure relief valves in water piping for domestic-water heaters without storage. Extend commercial-water-heater relief-valve outlet, with drain piping same as domestic-water piping in continuous downward pitch, and discharge by positive air gap onto closest floor drain.
- F. Install water-heater drain piping as indirect waste to spill by positive air gap into open drains or over floor drains. Install hose-end drain valves at low points in water piping for domestic-water

Weedsport Addition to Maintenance Section and Roof Replacement, MP 304.2

heaters that do not have tank drains. Comply with requirements for hose-end drain valves specified in Section 221119 "Domestic Water Piping Specialties."

- G. Install thermometer on outlet piping of domestic-water heaters. Comply with requirements for thermometers specified in Section 220519 "Meters and Gages for Plumbing Piping."
- H. Install piping-type heat traps on inlet and outlet piping of domestic-water heater storage tanks without integral or fitting-type heat traps.
- I. Fill domestic-water heaters with water.
- J. Charge domestic-water compression tanks with air.

3.2 CONNECTIONS

- A. Comply with requirements for domestic-water piping specified in Section 221116 "Domestic Water Piping."
- B. Drawings indicate general arrangement of piping, fittings, and specialties.
- C. Where installing piping adjacent to fuel-fired, domestic-water heaters, allow space for service and maintenance of water heaters. Arrange piping for easy removal of domestic-water heaters.

3.3 IDENTIFICATION

- A. Identify system components.

3.4 FIELD QUALITY CONTROL

- A. Perform tests and inspections.
 - 1. Manufacturer's Field Service: Engage a factory-authorized service representative to inspect components, assemblies, and equipment installations, including connections, and to assist in testing.
 - 2. Leak Test: After installation, charge system and test for leaks. Repair leaks and retest until no leaks exist.
 - 3. Operational Test: After electrical circuitry has been energized, start units to confirm proper operation.
 - 4. Test and adjust controls and safeties. Replace damaged and malfunctioning controls and equipment.
- B. Domestic-water heaters will be considered defective if they do not pass tests and inspections.
- C. Prepare test and inspection reports.

3.5 DEMONSTRATION

- A. Engage a factory-authorized service representative to train Owner's maintenance personnel to adjust, operate, and maintain commercial, gas-fired, storage, domestic-water heaters.

END OF SECTION 223400

SECTION 224213 - COMMERCIAL WATER CLOSETS & URINALS

PART 1 - GENERAL

1.1 RELATED DOCUMENTS

- A. Drawings and general provisions of the Contract, including General and Supplementary Conditions and Division 01 Specification Sections, apply to this Section.

1.2 SUMMARY

- A. Section Includes:
1. Water closets.
 2. Urinals.
 3. Flushometer valves.
 4. Toilet seats.

1.3 ACTION SUBMITTALS

- A. Product Data: For each type of product.
1. Include construction details, material descriptions, dimensions of individual components and profiles, and finishes for water closets.
 2. Include rated capacities, operating characteristics, electrical characteristics, and furnished specialties and accessories.

1.4 CLOSEOUT SUBMITTALS

- A. Operation and Maintenance Data: For flushometer valves to include in operation and maintenance manuals.

PART 2 - PRODUCTS

2.1 FLOOR-MOUNTED, BOTTOM-OUTLET WATER CLOSETS

- A. Water Closets **WC-1**: Accessible height, Floor mounted, bottom outlet, top spud.
1. Manufacturers: Subject to compliance with requirements, available manufacturers offering products that may be incorporated into the Work include, but are not limited to, the following:
 - a. American Standard America.
 - b. Gerber Plumbing Fixtures LLC.
 - c. Kohler Co. Equal to K95057
 - d. Mansfield Plumbing Products LLC.
 - e. TOTO USA, INC.
 - f. Zurn Industries, LLC; Commercial Brass and Fixtures.
 2. Bowl:
 - a. Standards: ASME A112.19.2/CSA B45.1 and ASME A112.19.5.
 - b. Material: Vitreous china.
 - c. Type: Siphon jet.
 - d. Style: Flushometer valve.
 - e. Height: Accessible/ "Right Height"
 - f. Rim Contour: Elongated.
 - g. Water Consumption: Range 1.1- 1.6 gal. per flush.

Weedsport Addition to Maintenance Section and Roof Replacement, MP 304.2

- h. Spud Size and Location: NPS 1-1/2; top.
 - i. Color: White.
 - 3. Bowl-to-Drain Connecting Fitting: ASTM A 1045 or ASME A112.4.3.
 - 4. Flushometer Valve: FV-1.
 - 5. Toilet Seat: Open front - required.
- B. Water Closets **WC-2**: Standard height Floor mounted, bottom outlet, top spud.
- 1. Manufacturers: Subject to compliance with requirements, available manufacturers offering products that may be incorporated into the Work include, but are not limited to, the following:
 - a. American Standard America.
 - b. Gerber Plumbing Fixtures LLC.
 - c. Kohler Co. Equal to K95053
 - d. Mansfield Plumbing Products LLC.
 - e. TOTO USA, INC.
 - f. Zurn Industries, LLC; Commercial Brass and Fixtures.
 - 2. Bowl:
 - a. Standards: ASME A112.19.2/CSA B45.1 and ASME A112.19.5.
 - b. Material: Vitreous china.
 - c. Type: Siphon jet.
 - d. Style: Flushometer valve.
 - e. Height: Standard.
 - f. Rim Contour: Elongated.
 - g. Water Consumption: Range 1.1- 1.6 gal. per flush.
 - h. Spud Size and Location: NPS 1-1/2; top.
 - i. Color: White.
 - 3. Bowl-to-Drain Connecting Fitting: ASTM A 1045 or ASME A112.4.3.
 - 4. Flushometer Valve: FV-1.
 - 5. Toilet Seat: Open front - required.

2.2 WALL-HUNG URINALS

- A. Urinals **UR-1**: Wall hung, back outlet, washout, accessible.
- 1. Manufacturers: Subject to compliance with requirements, available manufacturers offering products that may be incorporated into the Work include, but are not limited to, the following:
 - a. American Standard America.
 - b. Gerber Plumbing Fixtures LLC.
 - c. Kohler Co. Equal to K4991
 - d. Mansfield Plumbing Products LLC.
 - e. TOTO USA, INC.
 - f. Zurn Industries, LLC; Commercial Brass and Fixtures.
 - 2. Fixture:
 - a. Standards: ASME A112.19.2/CSA B45.1 and ASME A112.19.5.
 - b. Material: Vitreous china.
 - c. Type: Washout with extended shields.
 - d. Strainer or Trapway: Manufacturer's standard strainer with integral trap.
 - e. Water Consumption: Water saving 0.5 gpf.
 - f. Spud Size and Location: NPS 3/4, top.
 - g. Outlet Size and Location: NPS 2, back.
 - h. Color: White.

Weedsport Addition to Maintenance Section and Roof Replacement, MP 304.2

3. Flushometer Valve: FV-2.
4. Waste Fitting:
 - a. Standard: ASME A112.18.2/CSA B125.2 for coupling.
 - b. Size: NPS 2.
5. Support: ASME A112.6.1M, Type I, urinal carrier with fixture support plates and coupling with seal and fixture bolts and hardware matching fixture. Include rectangular, steel uprights.

2.3 FLUSHOMETER VALVES**A. Lever-Handle, Diaphragm Flushometer Valves FV-1:**

1. Manufacturers: Subject to compliance with requirements, available manufacturers offering products that may be incorporated into the Work include, but are not limited to, the following:
 - a. Sloan Valve Company. Equal to WES 111-1.28
 - b. Zurn Industries, LLC; Commercial Brass and Fixtures.
2. Standard: ASSE 1037.
3. Minimum Pressure Rating: 125 psig.
4. Features: Include integral check stop and backflow-prevention device.
5. Material: Brass body with corrosion-resistant components.
6. Exposed Flushometer-Valve Finish: Chrome plated.
7. Panel Finish: Chrome plated or stainless steel.
8. Style: Exposed.
9. Consumption: 1.28 gal. per flush.
10. Minimum Inlet: NPS 1.
11. Minimum Outlet: NPS 1-1/4.

B. Lever-Handle, Diaphragm Flushometer Valves FV-2:

1. Manufacturers: Subject to compliance with requirements, available manufacturers offering products that may be incorporated into the Work include, but are not limited to, the following:
 - a. Sloan Valve Company. Equal to 186-0.125
 - b. Coyne & Delany Co.
 - c. Gerber Plumbing Fixtures LLC.
 - d. Zurn Industries, LLC; Commercial Brass and Fixtures.
2. Standard: ASSE 1037.
3. Minimum Pressure Rating: 125 psig.
4. Features: Include integral check stop and backflow-prevention device.
5. Material: Brass body with corrosion-resistant components.
6. Exposed Flushometer-Valve Finish: Chrome plated.
7. Panel Finish: Chrome plated or stainless steel.
8. Style: Exposed.
9. Consumption: 0.125 gal. per flush.
10. Minimum Inlet: NPS 3/4.
11. Minimum Outlet: NPS 3/4.

C.**2.4 TOILET SEATS****A. Toilet Seats:**

Weedsport Addition to Maintenance Section and Roof Replacement, MP 304.2

1. Manufacturers: Subject to compliance with requirements, available manufacturers offering products that may be incorporated into the Work include, but are not limited to, the following:
 - a. American Standard America.
 - b. Bemis Manufacturing Company.
 - c. Church Seats.
 - d. Olsonite Seat Co.
 - e. TOTO USA, INC.
 - f. Zurn Industries, LLC; Commercial Brass and Fixtures.
2. Standard: IAPMO/ANSI Z124.5.
3. Material: Plastic.
4. Type: Commercial (Heavy duty).
5. Shape: Elongated rim, open front.
6. Hinge: Self-sustaining.
7. Hinge Material: Noncorroding metal.
8. Seat Cover: Not required.
9. Color: White.

PART 3 - EXECUTION

3.1 EXAMINATION

- A. Examine roughing-in of water supply and sanitary drainage and vent piping systems to verify actual locations of piping connections before water-closet installation.
- B. Examine walls and floors for suitable conditions where water closets will be installed.
- C. Proceed with installation only after unsatisfactory conditions have been corrected.

3.2 INSTALLATION

- A. Water-Closet Installation:
 1. Install level and plumb according to roughing-in drawings.
 2. Install floor-mounted water closets on bowl-to-drain connecting fitting attachments to piping or building substrate.
 3. Install accessible, wall-mounted water closets at mounting height for handicapped/elderly, according to ICC/ANSI A117.1.
- B. Urinal Installation:
 1. Install urinals level and plumb according to roughing-in drawings.
 2. Install wall-hung, back-outlet urinals onto waste fitting seals and attached to supports.
 3. Install accessible, wall-mounted urinals at mounting height for the handicapped/elderly, according to ICC/ANSI A117.1.
- C. Support Installation:
 1. Install supports, affixed to building substrate, for floor-mounted, back-outlet water closets.
 2. Use carrier supports with waste-fitting assembly and seal.
 3. Install floor-mounted, back-outlet water closets attached to building floor substrate, onto waste-fitting seals; and attach to support.
- D. Flushometer-Valve Installation:
 1. Install flushometer-valve, water-supply fitting on each supply to each water closet.

Weedsport Addition to Maintenance Section and Roof Replacement, MP 304.2

2. Attach supply piping to supports or substrate within pipe spaces behind fixtures.
 3. Install lever-handle flushometer valves for accessible water closets with handle mounted on open side of water closet.
 4. Install actuators in locations that are easy for people with disabilities to reach.
- E. Install toilet seats on water closets.
- F. Wall Flange and Escutcheon Installation:
1. Install wall flanges or escutcheons at piping wall penetrations in exposed, finished locations and within cabinets and millwork.
 2. Install deep-pattern escutcheons if required to conceal protruding fittings.
 3. Comply with escutcheon requirements specified in Section 220518 "Escutcheons for Plumbing Piping."
- G. Joint Sealing:
1. Seal joints between water closets and walls and floors using sanitary-type, one-part, mildew-resistant silicone sealant.
 2. Match sealant color to water-closet color.
 3. Comply with sealant requirements specified in Section 079200 "Joint Sealants."

3.3 CONNECTIONS

- A. Connect water closets with water supplies and soil, waste, and vent piping. Use size fittings required to match water closets.
- B. Comply with water piping requirements specified in Section 221116 "Domestic Water Piping."
- C. Comply with soil and waste piping requirements specified in Section 221316 "Sanitary Waste and Vent Piping."
- D. Where installing piping adjacent to water closets, allow space for service and maintenance.

3.4 ADJUSTING

- A. Operate and adjust water closets and controls. Replace damaged and malfunctioning water closets, fittings, and controls.
- B. Adjust water pressure at flushometer valves to produce proper flow.

3.5 CLEANING AND PROTECTION

- A. Clean water closets and fittings with manufacturers' recommended cleaning methods and materials.
- B. Install protective covering for installed water closets and fittings.
- C. Do not allow use of water closets for temporary facilities unless approved in writing by Owner.

END OF SECTION 224213

Weedsport Addition to Maintenance Section and Roof Replacement, MP 304.2

SECTION 224216 - COMMERCIAL SINKS & LAVATORIES

PART 1 - GENERAL

1.1 RELATED DOCUMENTS

- A. Drawings and general provisions of the Contract, including General and Supplementary Conditions and Division 01 Specification Sections, apply to this Section.

1.2 SUMMARY

- A. Section Includes:
1. Service Basins/Mop Receptor.
 2. Sinks.
 3. Lavatories.
 4. Sink faucets.
 5. Lavatory faucets
 6. Supply fittings.
 7. Waste fittings.

1.3 ACTION SUBMITTALS

- A. Product Data: For each type of product.
1. Include construction details, material descriptions, dimensions of individual components and profiles, and finishes for sinks.
 2. Include rated capacities, operating characteristics and furnished specialties and accessories.

1.4 CLOSEOUT SUBMITTALS

- A. Operations and Maintenance Data: For sinks, lavatories & faucets to include in operation and maintenance manuals.

PART 2 - PRODUCTS

2.1 SERVICE BASINS

- A. Service Basins/Mop Receptor MR-1: Molded stone, floor mounted.
1. Manufacturers: Subject to compliance with requirements, available manufacturers offering products that may be incorporated into the Work include, but are not limited to, the following:
 - a. Fiat Products.
 - b. Acorn Engineering Company.
 - c. Florestone Products Co., Inc.
 - d. Stern-Williams Co., Inc. Equal to SB-850
 2. Fixture:
 - a. Standard: IAPMO PS 99.
 - b. Shape: Rectangular.
 - c. Nominal Size: 24 by 24 inches.
 - d. Height: 12 inches.
 - e. Rim Guard: On all top surfaces.

Weedsport Addition to Maintenance Section and Roof Replacement, MP 304.2

- f. Color: Not applicable.
 - g. Drain: Grid with NPS 3 outlet.
3. Mounting: On floor and flush to wall.
 4. Faucet: **SF-2**: Equal to T&S Brass B-0655-BSTP wall mount with vacuum breaker, 3/4" hose thread, pail hook, adjustable wall brace and 8" center four arm handles.
 5. Accessories: Equal to Fiat 832-AA and 833-AA
 6. Faucets complete with in line check valves on both HW and CW supply to Mop sink Faucet (in addition to faucet vacuum breaker)

2.2 GENERAL REQUIREMENTS FOR LAVATORIES

- A. Potable-water piping, and components shall comply with NSF 61.
- B. Per new Federal Lead-Free Law, any product designed for dispensing potable water meet both the NSF 61 and NSF 372 test standards via third-party testing and certification.

2.3 SINKS

- A. Sinks **SK-1**: Stainless steel, counter mounted, Double Bowl, Deep, gooseneck/wrist blade.
 1. Manufacturers: Subject to compliance with requirements, available manufacturers offering products that may be incorporated into the Work include, but are not limited to, the following:
 - a. Just Manufacturing.
 - b. Elkay Manufacturing Co. Equal to ECTSRAD33226BG
 2. Fixture:
 - a. Standard: ASME A112.19.3/CSA B45.4.
 - b. Type: Ledge back.
 - c. Number of Compartments: Two.
 - d. Overall Dimensions:
 - e. Metal Thickness: 18 gauge
 - f. Compartment:
 - 1) Dimensions: OD 33x22, ID 14 3/4x16 3/4 each.
 - 2) Depth: 6"
 - 3) Drain: Grid with NPS 1-1/2 tailpiece and twist drain.
 - 4) Drain Location: Centered in compartment.
 3. Faucet(s): **SF-1**.
 - a. Number Required: One.
 - b. Mounting: On ledge.
 4. Supply Fittings:
 - a. Standard: ASME A112.18.1/CSA B125.1.
 - b. Supplies: Chrome-plated brass compression stop with inlet connection matching water-supply piping type and size.
 - 1) Operation: Loose key.
 - 2) Risers: NPS 1/2, chrome-plated, rigid-copper pipe or ASME A112.18.6, braided or corrugated stainless-steel flexible hose.
 5. Waste Fittings:
 - a. Standard: ASME A112.18.2/CSA B125.2.
 - b. Trap(s):
 - 1) Size: NPS 1-1/2.

Weedsport Addition to Maintenance Section and Roof Replacement, MP 304.2

- 2) Material: Chrome-plated, two-piece, cast-brass trap and swivel elbow with 0.032-inch- thick brass tube to wall; and chrome-plated brass or steel wall flange.
6. Mounting: On counter with sealant.

2.4 VITREOUS-CHINA, WALL-MOUNTED LAVATORIES

- A. Lavatory **LAV-1**: Accessible height, Vitreous china, wall mounted, with back for hand wash.
1. Manufacturers: Subject to compliance with requirements, available manufacturers offering products that may be incorporated into the Work include, but are not limited to, the following:
 - a. American Standard America.
 - b. Gerber Plumbing Fixtures LLC.
 - c. Kohler Co. Equal to K2005
 - d. Mansfield Plumbing Products LLC.
 - e. Zurn Industries, LLC; Commercial Brass and Fixtures.
 2. Fixture:
 - a. Standard: ASME A112.19.2/CSA B45.1.
 - b. Type: For wall hanging.
 - c. Nominal Size: 20 by 18 inches.
 - d. Faucet-Hole Punching: 4" centers
 - e. Faucet-Hole Location: Top.
 - f. Color: White.
 - g. Mounting Material: Chair carrier.
 3. Faucet: **LF-1**.
 4. Support: ASME A112.6.1M, Type II, concealed-arm lavatory carrier with escutcheons.
 5. Protective Insulation Shielding Guards, Per ADA requirements: Required

2.5 SINK FAUCETS

- A. NSF Standard: Comply with NSF/ANSI 61, "Drinking Water System Components - Health Effects," for faucet-spout materials that will be in contact with potable water.
- B. Sink Faucets **SF-1**: Manual type, two-lever-handle mixing valve, Swing spout wrist blade handles.
1. Manufacturers: Subject to compliance with requirements, available manufacturers offering products that may be incorporated into the Work include, but are not limited to, the following:
 - a. Chicago Faucets. Equal to 1100-HA8-ABCP
 - b. American Standard America.
 - c. Bradley Corporation.
 - d. Just Manufacturing.
 - e. Speakman Company.
 - f. T & S Brass and Bronze Works, Inc.
 - g. Zurn Industries, LLC; Commercial Brass and Fixtures.
 2. Standard: ASME A112.18.1/CSA B125.1.
 3. General: Include hot- and cold-water indicators; coordinate faucet inlets with supplies and fixture hole punching; coordinate outlet with spout and sink receptor.
 4. Body Type: 8" Centers.
 5. Body Material: Commercial, solid brass.

Weedsport Addition to Maintenance Section and Roof Replacement, MP 304.2

6. Finish: Chrome plated.
7. Maximum Flow Rate: 1.5 GPM
8. Handle(s): 4" Wrist blade handles.
9. Mounting Type: Deck, concealed.
10. Spout Type: Rigid/Swing gooseneck.
11. Spout Outlet: Laminar flow.

2.6 SOLID-BRASS, MANUALLY OPERATED FAUCETS

- A. NSF Standard: Comply with NSF/ANSI 61, "Drinking Water System Components - Health Effects," for faucet materials that will be in contact with potable water.
- B. Per new Federal Lead-Free Law, any product designed for dispensing potable water meet both the NSF 61 and NSF 372 test standards via third-party testing and certification.
- C. Lavatory Faucets **LF-1**: Manual-type, two handle mixing, commercial, solid-brass valve. 4" wrist blades
 1. Manufacturers: Subject to compliance with requirements, available manufacturers offering products that may be incorporated into the Work include, but are not limited to, the following:
 - a. T & S Brass and Bronze Works, Inc
 - b. Chicago Faucet. Equal to 802-317-ABCP
 - c. Watts.
 - d. American Standard America.
 - e. Speakman Company.
 - f. T & S Brass and Bronze Works, Inc.
 - g. Zurn Industries, LLC; Commercial Brass and Fixtures.
 2. Standard: ASME A112.18.1/CSA B125.1.
 3. General: Include hot- and cold-water indicators; coordinate faucet inlets with supplies and fixture hole punchings; coordinate outlet with spout and fixture receptor.
 4. Body Type: Three hole.
 5. Body Material: Commercial, solid brass.
 6. Finish: Polished chrome plate.
 7. Maximum Flow Rate: 0.5 gpm
 8. Mounting Type: Deck, exposed.
 9. Valve Handle(s): 4" Wrist Blades.
 10. Spout: Rigid type.
 11. Operation: Manual.

2.7 SUPPLY FITTINGS

- A. NSF Standard: Comply with NSF/ANSI 61, "Drinking Water System Components - Health Effects," for supply-fitting materials that will be in contact with potable water.
- B. Standard: ASME A112.18.1/CSA B125.1.
- C. Supply Piping: Chrome-plated brass pipe or chrome-plated copper tube matching water-supply piping size. Include chrome-plated brass or stainless-steel wall flange.

Weedsport Addition to Maintenance Section and Roof Replacement, MP 304.2

- D. Supply Stops: Chrome-plated brass, one-quarter-turn, ball-type or compression valve with inlet connection matching supply piping.
- E. Operation: Loose key.
- F. Risers:
 1. NPS 1/2
 2. Chrome-plated, rigid-copper pipe or ASME A112.18.6, braided or corrugated stainless-steel flexible hose.

2.8 WASTE FITTINGS

- A. Standard: ASME A112.18.2/CSA B125.2.
- B. Drain: Grid type with NPS 1-1/2 offset and straight tailpiece.
- C. Trap:
 1. Size: NPS 1-1/2.
 2. Material: Chrome-plated, two-piece, cast-brass trap and swivel elbow with 0.032-inch-thick brass tube to wall Insert trap type; and chrome-plated brass or steel wall flange.

2.9 GROUT

- A. Standard: ASTM C 1107/C 1107M, Grade B, post-hardening and volume-adjusting, dry, hydraulic-cement grout.
- B. Characteristics: Nonshrink; recommended for interior and exterior applications.
- C. Design Mix: 5000-psi, 28-day compressive strength.
- D. Packaging: Premixed and factory packaged.

PART 3 - EXECUTION

3.1 EXAMINATION

- A. Examine roughing-in of water supply and sanitary drainage and vent piping systems to verify actual locations of piping connections before sink installation.
- B. Examine walls, floors, and counters for suitable conditions where sinks will be installed.
- C. Proceed with installation only after unsatisfactory conditions have been corrected.

3.2 INSTALLATION

- A. Install sinks level and plumb according to roughing-in drawings.
- B. Install supports, affixed to building substrate, for wall-hung sinks.
- C. Install accessible wall-mounted sinks at handicapped/elderly mounting height according to ICC/ANSI A117.1.
- D. Set floor-mounted sinks in leveling bed of cement grout.
- E. Install water-supply piping with stop on each supply to each sink faucet.

Weedsport Addition to Maintenance Section and Roof Replacement, MP 304.2

1. Exception: Use ball, gate, or globe valves if supply stops are not specified with sink. Comply with valve requirements specified in Section 220523 "General-Duty Valves for Plumbing Piping."
 2. Install stops in locations where they can be easily reached for operation.
- F. Install wall flanges or escutcheons at piping wall penetrations in exposed, finished locations. Use deep-pattern escutcheons if required to conceal protruding fittings. Comply with escutcheon requirements specified in Section 220518 "Escutcheons for Plumbing Piping."
- G. Seal joints between sinks and counters, floors, and walls using sanitary-type, one-part, mildew-resistant silicone sealant. Match sealant color to fixture color. Comply with sealant requirements specified in Section 079200 "Joint Sealants."
- H. Install protective shielding pipe covers and enclosures on exposed supplies and waste piping of accessible sinks. Comply with requirements in Section 220719 "Plumbing Piping Insulation."

3.3 CONNECTIONS

- A. Connect sinks with water supplies, stops, and risers, and with traps, soil, waste, and vent piping. Use size fittings required to match fixtures.
- B. Comply with water piping requirements specified in Section 221116 "Domestic Water Piping."
- C. Comply with soil and waste piping requirements specified in Section 221316 "Sanitary Waste and Vent Piping."

3.4 ADJUSTING

- A. Operate and adjust sinks and controls. Replace damaged and malfunctioning sinks, fittings, and controls.
- B. Adjust water pressure at faucets to produce proper flow.

3.5 CLEANING AND PROTECTION

- A. After completing installation of sinks, inspect and repair damaged finishes.
- B. Clean sinks, faucets, and other fittings with manufacturers' recommended cleaning methods and materials.
- C. Provide protective covering for installed sinks and fittings.
- D. Do not allow use of sinks for temporary facilities unless approved in writing by Owner.

END OF SECTION 224216

SECTION 224223 - COMMERCIAL SHOWERS

PART 1 - GENERAL

1.1 RELATED DOCUMENTS

- A. Drawings and general provisions of the Contract, including General and Supplementary Conditions and Division 01 Specification Sections, apply to this Section.

1.2 SUMMARY

- A. Section Includes:
1. Shower faucets.

1.3 ACTION SUBMITTALS

- A. Product Data: For each type of product.
1. Include construction details, material descriptions, dimensions of individual components and profiles, and finishes for showers and basins.
 2. Include rated capacities, operating characteristics, and furnished specialties and accessories.

1.4 CLOSEOUT SUBMITTALS

- A. Maintenance Data: For shower faucets to include in maintenance manuals.

PART 2 - PRODUCTS

2.1 INDIVIDUAL SHOWERS

2.2 SHOWER FAUCETS

- A. NSF Standard: Comply with NSF 61, "Drinking Water System Components - Health Effects," for shower materials that will be in contact with potable water.
- B. Per new Federal Lead-Free Law, any product designed for dispensing potable water meet both the NSF 61 and NSF 372 test standards via third-party testing and certification.
- C. Shower Faucets SH-1:
1. Manufacturers: Subject to compliance with requirements, available manufacturers offering products that may be incorporated into the Work include, but are not limited to, the following:
 - a. Symmons Equal to 1-901S-FSB
 - b. Chicago Faucets.
 - c. Kohler Co.
 - d. Moen Incorporated.
 - e. Powers; a division of Watts Water Technologies, Inc.
 - f. Speakman Company.
 2. Description: Single-handle, pressure-balance mixing valve with hot- and cold-water indicators; check stops; and shower head.
 3. Faucet:
 - a. Standards: ASME A112.18.1/CSA B125.1 and ASSE 1016.
 - b. Body Material: Solid brass.

Weedsport Addition to Maintenance Section and Roof Replacement, MP 304.2

- c. Finish: Polished chrome plate.
 - d. Maximum Flow Rate: 2.2 GPM unless otherwise indicated.
 - e. Mounting: Concealed.
 - f. Operation: Single-handle, twist or rotate control.
 - g. Antiscald Device: Integral with mixing valve.
 - h. Check Stops: Check-valve type, integral with or attached to body; on hot- and cold-water supply connections.
- 4. Supply Connections: NPS 1/2.
 - 5. Shower Heads (one fixed and one handheld):
 - a. Standard: ASME A112.18.1/CSA B125.1.
 - b. Type: Ball joint with arm and flange.
 - c. Shower Head Material: Metallic with chrome-plated finish.
 - d. Spray Pattern: Adjustable.
 - e. Integral Volume Control: Required.
 - f. Wall/Hand shower head with in-line vacuum breaker, 5' metal hose, wall connection and flange with 30" slide bar and associated diverter valve.
 - g. associated diverter valve.

2.3 GROUT

- A. Standard: ASTM C 1107/C 1107M, Grade B, post-hardening and volume-adjusting, dry, hydraulic-cement grout.
- B. Characteristics: Nonshrink; recommended for interior and exterior applications.
- C. Design Mix: 5000-psi, 28-day compressive strength.
- D. Packaging: Premixed and factory packaged.

PART 3 - EXECUTION**3.1 EXAMINATION**

- A. Examine roughing-in of water-supply and sanitary drainage and vent piping systems to verify actual locations of piping connections before shower installation.
- B. Examine walls and floors for suitable conditions where showers will be installed.
- C. Proceed with installation only after unsatisfactory conditions have been corrected.

3.2 INSTALLATION

- A. Assemble shower components according to manufacturers' written instructions.
- B. Install showers level and plumb according to roughing-in drawings.
- C. Install water-supply piping with stop on each supply to each shower faucet.
 - 1. Exception: Use ball, gate, or globe valves if supply stops are not specified with shower. Comply with valve requirements specified in Section 220523 "General-Duty Valves for Plumbing Piping."
 - 2. Install stops in locations where they can be easily reached for operation.
- D. Install shower flow-control fittings with specified maximum flow rates in shower arms.
- E. Set shower receptors in leveling bed of cement grout.

Weedsport Addition to Maintenance Section and Roof Replacement, MP 304.2

- F. Install wall flanges or escutcheons at piping wall penetrations in exposed, finished locations. Use deep-pattern escutcheons if required to conceal protruding fittings. Comply with escutcheons requirements specified in Section 220518 "Escutcheons for Plumbing Piping."
- G. Seal joints between showers and floors and walls using sanitary-type, one-part, mildew-resistant silicone sealant. Match sealant color to fixture color. Comply with sealant requirements specified in Section 079200 "Joint Sealants."

3.3 CONNECTIONS

- A. Connect fixtures with water supplies, stops, and risers, and with traps, soil, waste, and vent piping. Use size fittings required to match fixtures.
- B. Comply with water piping requirements specified in Section 221116 "Domestic Water Piping."
- C. Comply with traps and soil and waste piping requirements specified in Section 221316 "Sanitary Waste and Vent Piping."

3.4 ADJUSTING

- A. Operate and adjust showers and controls. Replace damaged and malfunctioning showers, fittings, and controls.
- B. Adjust water pressure at faucets to produce proper flow.

3.5 CLEANING AND PROTECTION

- A. After completing installation of showers and basins, inspect and repair damaged finishes.
- B. Clean showers and basins, faucets, and other fittings with manufacturers' recommended cleaning methods and materials.
- C. Provide protective covering for installed fixtures and fittings.
- D. Do not allow use of showers and basins for temporary facilities unless approved in writing by Owner.

END OF SECTION 224223

SECTION 224716 - PRESSURE WATER COOLERS

PART 1 - GENERAL

1.1 RELATED DOCUMENTS

- A. Drawings and general provisions of the Contract, including General and Supplementary Conditions and Division 01 Specification Sections, apply to this Section.

1.2 SUMMARY

- A. Section includes pressure water coolers and related components.

1.3 ACTION SUBMITTALS

- A. Product Data: For each type of pressure water cooler.
 1. Include construction details, material descriptions, dimensions of individual components and profiles, and finishes.
 2. Include rated capacities, operating characteristics, electrical characteristics, and furnished specialties and accessories.

1.4 CLOSEOUT SUBMITTALS

- A. Maintenance Data: For pressure water coolers to include in maintenance manuals.

PART 2 - PRODUCTS

2.1 PRESSURE WATER COOLERS

- A. Pressure Water Coolers **EWC-1**: Wall mounted, dual height, accessible, with bottle filler.
 1. Manufacturers: Subject to compliance with requirements, available manufacturers offering products that may be incorporated into the Work include, but are not limited to, the following:
 - a. Elkay Manufacturing Co. Equal to EZSTL8WSLK
 - b. Halsey Taylor.
 - c. Haws Corporation.
 - d. Tri Palm International, LLC; Oasis Brand.
 2. Cabinet: Bi-level with two attached cabinets, vinyl-covered steel with stainless-steel top, one bottle filler station above one cabinet.
 3. Bubbler: One, with adjustable stream regulator, located on each cabinet deck.
 4. Control: Push bar.
 5. Drain: Grid with NPS 1-1/4 tailpiece.
 6. Supply: NPS 3/8 with shutoff valve.
 7. Filter: Filter NSF 42 & 53 for lead and particulate w/ visual filter monitor.
 8. Waste Fitting: ASME A112.18.2/CSA B125.2, NPS 1-1/4 brass P-trap.
 9. Cooling System: Electric, with hermetically sealed compressor, cooling coil, air-cooled condensing unit, corrosion-resistant tubing, refrigerant, corrosion-resistant-metal storage tank, and adjustable thermostat.
 - a. Electrical Components, Devices, and Accessories: Listed and labeled as defined in NFPA 70, by a qualified testing agency, and marked for intended location and application.
 10. Capacities and Characteristics:

Weedsport Addition to Maintenance Section and Roof Replacement, MP 304.2

- a. Cooled Water: 8 gph.
 - b. Cooled-Water Temperature: 50 deg F.
 - c. Electrical Characteristics:
 - 1) Volts: 120-V ac.
 - 2) Phase: Single.
 - 3) Hertz: 60.
11. Support: ASME A112.6.1M, Type I water-cooler carrier.

PART 3 - EXECUTION

3.1 EXAMINATION

- A. Examine roughing-in for water-supply and sanitary drainage and vent piping systems to verify actual locations of piping connections before fixture installation.
- B. Examine walls and floors for suitable conditions where fixtures will be installed.
- C. Proceed with installation only after unsatisfactory conditions have been corrected.

3.2 INSTALLATION

- A. Install fixtures level and plumb according to roughing-in drawings. For fixtures indicated for children, install at height required by authorities having jurisdiction.
- B. Install off-the-floor carrier supports, affixed to building substrate, for wall-mounted fixtures.
- C. Install water-supply piping with shutoff valve on supply to each fixture to be connected to domestic-water distribution piping. Use ball, gate, or globe valve. Install valves in locations where they can be easily reached for operation.
- D. Install trap and waste piping on drain outlet of each fixture to be connected to sanitary drainage system.
- E. Install wall flanges or escutcheons at piping wall penetrations in exposed, finished locations. Use deep-pattern escutcheons where required to conceal protruding fittings.
- F. Seal joints between fixtures and walls using sanitary-type, one-part, mildew-resistant, silicone sealant. Match sealant color to fixture color.

3.3 CONNECTIONS

- A. Connect fixtures with water supplies, stops, and risers, and with traps, soil, waste, and vent piping. Use size fittings required to match fixtures.
- B. Comply with water piping requirements specified in Section 221116 "Domestic Water Piping."
- C. Install ball, gate, or globe shutoff valve on water supply to each fixture.
- D. Comply with soil and waste piping requirements specified in Section 221316 "Sanitary Waste and Vent Piping."

3.4 ADJUSTING

- A. Adjust fixture flow regulators for proper flow and stream height.
- B. Adjust pressure water-cooler temperature settings.

Weedsport Addition to Maintenance Section and Roof Replacement, MP 304.2

3.5 CLEANING

- A. After installing fixture, inspect unit. Remove paint splatters and other spots, dirt, and debris. Repair damaged finish to match original finish.
- B. Clean fixtures, on completion of installation, according to manufacturer's written instructions.
- C. Provide protective covering for installed fixtures.
- D. Do not allow use of fixtures for temporary facilities unless approved in writing by Owner.

END OF SECTION 224716

ITEM 627.0023 25**HEATING, VENTILATING, AND AIR CONDITIONING****1. DESCRIPTION:**

- 1.01 Furnish all labor, materials, equipment and services necessary to complete the work as indicated on the Contract Plans and the attached Specification Summary.
- 1.04 All work shall conform to the requirements specified in Part 1 – General, of the Sections listed.

2. MATERIALS:

- 2.01 The materials shall be as specified in Part 2 – Products, of the Sections listed.

3. CONSTRUCTION DETAILS:

- 3.01 The construction details shall be as specified on Part 3 – Execution, if the Sections listed.

4. METHOD OF MEASUREMENT:

- 4.01 This item shall be measured for payment on a lump sum basis for the work completed in accordance with the Contract Documents and as directed by the Engineer.

5. BASIS OF PAYMENT:

- 5.01 Payment for this item shall be made at the lump sum bid price bid. The lump sum price bid shall include cost of furnishing all labor, material, equipment and appliances necessary to complete the work as indicated on the Contract Plans and as specified herein in the Sections listed.
- 5.02 Detailed Estimate:
 - A. Before the first certificate of payment is issued for the work under this item, submit a detailed estimate of quantities and prices for all materials, labor, and other items included under this item, which shall aggregate the contract lump sum price bid for this item. Prepare the detailed estimate in the same sequence as the Sections listed.
 - B. The detailed estimate shall be supported by such evidence, including certified copies of subcontracts, as the Engineer may require.
 - C. The detailed estimate must be approved by the Engineer who may revise it as, in his/her reasonable judgment, is necessary to make the various item conform to their true values. The value of each certificate of payment will be based on the approved detailed estimate.
- 5.03 Monthly payments will be made for this item in proportion to the total amount of work completed.

ITEM 627.0023 25**HEATING, VENTILATING, AND AIR CONDITIONING****1. SPECIFICATION SUMMARY**

1.01 This Item includes the following specifications:

- A. Section 230001 GENERAL PROVISIONS FOR MECHANICAL WORK
- B. Section 230002 MECHANICAL AND ELECTRICAL COORDINATION
- C. Section 230513 COMMON MOTOR REQUIREMENTS FOR HVAC EQUIPMENT
- D. Section 230553 IDENTIFICATION FOR HVAC PIPING AND EQUIPMENT
- E. Section 230593 TESTING, ADJUSTING, AND BALANCING FOR HVAC
- F. Section 230713 DUCT INSULATION
- G. Section 233113 METAL DUCTS
- H. Section 233300 AIR DUCT ACCESSORIES
- I. Section 233423 HVAC POWER VENTILATORS
- J. Section 233713 DIFFUSERS, REGISTERS, AND GRILLES
- K. Section 237413 PACKAGED, OUTDOOR CENTRAL-STATION AIR-HANDLING UNITS

1.02 This item shall include, but not be limited to, the following:

- A. HVAC units needed for the building's addition
- B. Ductwork for the building's addition
- C. Diffusers, registers, and grilles to be placed in the ceiling of the addition

SECTION 230001 - GENERAL PROVISIONS FOR MECHANICAL WORK

PART 1 - GENERAL

1.1 RELATED DOCUMENTS

- A. Drawings and general provisions of the Contract, including General and Supplementary Conditions and Division 01 Specification Sections, apply to this Section.
- B. Requirements of this Section apply to work in every Section of Division 23 equally as if incorporated therein.

1.2 WORK INCLUDED

- A. Work included in Division 23 - Mechanical: Materials, equipment, fabrication, installation and tests in conformity with applicable codes and authorities having jurisdiction for Mechanical Work covered by all sections within this Division.

1.3 SCOPE

- A. Division of the Specification into sections is for the purpose of simplification alone. Responsibility for the work of various trades shall rest with the Contractor. Various sections of this Division are related to each other as well as the mechanical drawings. Examine all drawings and read all applicable parts of the project manual in order to ensure complete execution of all work in this Division, coordinating where required with other trades in order to avoid conflicts.
- B. These specifications and accompanying drawings are intended to cover the furnishing of all labor, materials, equipment and services necessary for the complete installation and acceptable performance of the mechanical systems. Small items of material, equipment and appurtenances not mentioned in detail or shown on the drawings, but necessary for complete and operating systems shall be provided by this contractor without additional charge to the Owner and shall be included under this contract.
- C. In general, specifications establish the quality of material, equipment and workmanship. The contract documents are intended to secure for the Owner, a first-class installation in every respect. Labor shall be performed by skilled mechanics, and the entire facility, when delivered to the Owner, shall be ready for satisfactory and efficient operation.
- D. The Contractor shall carefully examine the drawings and specifications before accepting the contract. He shall call attention to any changes or additions which, in his opinion, are necessary to make possible the fulfillment of any guarantee called for by these specifications; failing which, it shall be deemed that he has accepted full responsibility for all such guarantees.
- E. The contractor shall put his work in place as fast as is reasonably possible. He shall, at all times, keep a competent foreman in charge of the work, to make decisions necessary for the diligent advancement of the work. The Contractor shall facilitate the inspection of the work by the Owner's Representative.

Weedsport Addition to Maintenance Section and Roof Replacement, MP 304.2

- F. The Contractor shall coordinate all work in the building in order to facilitate intelligent execution of the work. He shall also remove any rubbish as expeditiously as possible.
- G. Materials or products specified herein and/or indicated on the drawings by trade's names, manufacturer's names, model number or catalog numbers establish the quality of materials or products to be furnished. Model numbers are to be confirmed by the manufacturer to provide required capacities and material to meet the specifications and design intent. In no instance shall an obsolete, incomplete or inaccurate trade name, manufacturer name, model number or catalog number indicated on the drawings, result in additional charges to the owner.
- H. Points of connection or continuation of work under this contract are so marked on drawings or herein specified. In case of any doubt as to the required exact location of such points, the Owner's Representative shall decide and direct.
- I. The plumbing contractor shall provide water services to within two (2) feet of HVAC equipment requiring same, and shall terminate service with a shutoff valve. The mechanical contractor shall make the final connection to the equipment.

1.4 REFERENCE STANDARDS, CODES AND REGULATIONS

- A. Requirements of Regulatory Agencies:
 - 1. Nothing contained in these specifications or shown on the drawings shall be construed to conflict with any State or local laws, ordinances, rules and regulations, the UL and NFPA regulations. The Contractor shall make all changes required by the enforcing authorities. Where alterations to and / or deviations from the Contract Documents are required by the authorities having jurisdiction, report the requirements to the Engineer and secure acceptance before work is started. All such changes shall be made in a manner acceptable to the Engineer and shall be made without cost to the Owner.
 - 2. When drawings or specifications exceed requirements of applicable laws, ordinances, rules and regulations, comply with documents establishing the more stringent requirement. All work shall be done in full conformity with the requirements of all authorities having jurisdiction. Installation shall be made in compliance with all applicable regulations, and utility company rules, all of which shall be considered a part of this specification and shall take precedence in the order of listing.
 - 3. It is not the intent of drawings or specifications to repeat requirements of codes except where necessary for completeness in individual sections.
- B. Published specifications, standards, tests or recommended method of trade, industry or governmental organizations as listed below apply to all work in this Division, in addition to other standards which may be specified in individual sections:
 - 1. AABC Associated Air Balance Council
 - 2. ADC Air Diffuser Balance Council
 - 3. AMCA Air Moving and Conditioning Association
 - 4. AGA American Gas Association
 - 5. ANSI American National Standards Institute
 - 6. ARI Air Conditioning and Refrigeration Institute
 - 7. ASHRAE American Society of Heating, Refrigeration and Air Conditioning Engineers
 - 8. ASME American Society of Mechanical Engineers
 - 9. ASTM American Society for Testing and Materials

Weedsport Addition to Maintenance Section and Roof Replacement, MP 304.2

10.	CISPI	Cast Iron Soil Pipe Institute
11.	ETL	ETL Testing Laboratories
12.	FMS	Factory Mutual Engineering and Research Corporation
13.	NAPHCC	National Standard Plumbing Code
14.	NEMA	National Electrical Manufacturer's Association
15.	NFPA	National Fire Protection Association
16.	NBFU	National Board of Fire Underwriters
17.	NEC	National Electric Code
18.	OSHA	Occupational Safety and Health Administration
19.	PDI	Plumbing Drainage Institute
20.	SMACNA	Sheet Metal & Air Conditioning Contractors National Association
21.	UL	Underwriters Laboratories, Inc.

- C. Furnish and file with the proper authorities, all drawings required by them in connection with the work. Contractor shall secure and obtain all approvals, permits, licenses and inspections and pay all legal and proper fees and charges in this connection, before commencing work in order to avoid delays during construction. He shall deliver the official records of the granting of the permits, etc., to the Owner's Representative.

1.5 1.5 QUALITY ASSURANCE

- A. All equipment and accessories to be the product of a manufacturer regularly engaged in its manufacture.
- B. Supply all equipment and accessories new and free from defects.
- C. Supply all equipment and accessories in compliance with the applicable standards listed in Article 1.4 of this section with all applicable national, state and local codes.
- D. All items of a given type shall be the product of same manufacturer.

1.6 DESCRIPTION OF BID DOCUMENTS

- A. Specifications:
1. Specifications, in general, describe quality and character of materials and equipment.
 2. Specifications are of simplified form and include incomplete sentences.
 3. Words or phrases such as "The Contractor shall", "shall be", "furnish", "provide", "a", "an", "the", and "all" may have been omitted for brevity.
- B. Drawings: Mechanical drawings under this contract are made a part of these specifications. Deviations from these specifications as noted below must have the approval of the Engineer or Construction Manager without an increase in contract price.
1. The drawings shall be considered as being diagrammatic and for bidding purposes only. Intention is to show size, capacity, approximate location, direction and general relationship of one work phase to another, but not exact detail or arrangement. The attention of the contractor is called to the fact that while these drawings are generally to scale and are made as accurately as the scale will permit, all critical dimensions shall be determined in the field. They are not to be considered as erection drawings.

Weedsport Addition to Maintenance Section and Roof Replacement, MP 304.2

2. The drawings do not indicate every fitting, elbow, offset, valve, etc. which is required to complete the job. Contractor shall prepare field erection drawings as required for the use of his mechanics to insure proper installation.
 3. Scaled and figured dimensions are approximate and are for estimating purposes only. Indicated dimensions are limiting dimensions.
 4. Before proceeding with work check and verify all dimensions in field.
 5. Assume all responsibility for fitting of materials and equipment to other parts of equipment and structure.
 6. Make adjustments that may be necessary or requested in order to resolve space problems, preserve headroom, and avoid architectural openings, structural members and work of other trades.
 7. For exact locations of building elements, refer to dimensional Architectural/Structural drawings.
- C. Description of systems: Provide all materials to provide functioning systems in compliance with performance requirements specified, and any modifications resulting from reviewed shop drawings and field coordinated drawings.
1. Installation of all systems and equipment is subject to clarification as indicated in reviewed shop drawings and field coordination drawings.
- D. Do not use equipment exceeding dimensions indicated or equipment or arrangements that reduce required clearances or exceed specified maximum dimensions.
- E. If any part of Specifications or Drawings appears unclear or contradictory, apply to Architect for his interpretation and decision as early as possible, including during bidding period.
1. Do not proceed with work without Engineer's decision.

1.7 EQUIPMENT MANUFACTURERS

- A. The first named manufacturer is used as the basis of design. Other named manufacturers are identified as equivalent manufacturers, not equivalent products. Naming other manufacturers does not necessarily imply conformance of any specific product with the written specifications.
- B. The contractor is required to verify that equipment and material to be used on the project meets the requirements of the specifications and will physically fit the available space, clearance and service requirements of the particular piece of equipment and include all pertinent information when he submits material for acceptance. Contractor shall also be responsible for and bear the cost of any modifications to openings available or anticipated as being available for rigging equipment to its final installation place. This shall include openings in exterior envelope, walls and roofs, interior walls, corridors, passage ways or door openings. Any on site dismantling and any reassembly of equipment made necessary by impediment to the rigging of said equipment shall be the sole responsibility of the contractor.
- C. Contract document indicates power and physical requirements based on the equipment manufacturer's data as first named. If equipment requiring more system capacity is furnished, the contractor shall be responsible for the cost associated with modifying the design and installation of associated services, including any redesign costs associated with the engineer's review.

1.8 DEFINITIONS

- A. "Provide": To supply, furnish, install and connect up complete and ready safe and regular operation of particular work referred to unless specifically noted.
- B. "Install": To erect, mount and connect complete with related accessories.
- C. "Supply", "Furnish": To purchase, procure, acquire and deliver complete with related accessories.
- D. "Work": Labor, materials, equipment, apparatus, controls, accessories, and other items required for proper and complete installation.
- E. "Piping": Pipe, tube, fittings, flanges, valves, controls, strainers, hangers, supports, unions, traps, drains, insulation, and related items.
- F. "Wiring": Raceway, fittings, wire, boxes and related items.
- G. "Concealed": Items referred to as hidden from normal sight, embedded in masonry or other construction, installed in furred spaces, within double partitions or hung ceilings, in trenches, in crawl spaces, or in enclosures.
- H. "Exposed": Not installed underground or "concealed" as defined above.
- I. "Indicated", "Shown", or "Noted": As indicated, shown or noted on drawings or specifications.
- J. "Directed": Directed by Engineer.
- K. "Similar" or "Equal": Of base bid manufacture, equal in materials, weight, size, design, and efficiency of specified product.
- L. "Reviewed", "Satisfactory", or "Directed": As reviewed, satisfactory, or directed by or to Engineer.
- M. "Motor Controllers": Manual or magnetic starters (with or without switches), individual pushbuttons or hand-off-automatic (HOA) switches controlling the operation of motors.
- N. "Control or Actuating Devices": Automatic sensing and switching devices such as thermostats, pressure, float, electro-pneumatic switches and electrodes controlling operation of equipment.
- O. "Remove": Dismantle, demolish and take away from the site and dispose of in accordance with all applicable rules and regulations or, should the Owner so require, deliver to a location as designated by the Owner for the use of the Owner, at no additional costs to the Owner.
- P. "Replace": Remove existing and provide an equivalent product or material as specified.
- Q. "Extract (and Reinstall) ": Carefully disassemble, dismantle existing, save or store where directed by the Owner, in such a manner as to preserve the existing condition and reinstall as indicated on the drawings or as described in the specifications.

Weedsport Addition to Maintenance Section and Roof Replacement, MP 304.2

- R. Where any device or piece of equipment is referred to in the singular number, such reference shall be deemed to apply to as many devices as are required to complete the installation.

1.9 JOB CONDITIONS

- A. This contractor shall investigate all conditions affecting his work and shall provide such offsets, fittings, valves, sheet metal work, etc., as may be required to meet conditions at the building.
- B. The contractor shall verify all measurements at the building site and shall be responsible for the correctness of same before ordering materials or before starting work of any Section.
1. Report to Architect, in writing, conditions which will prevent proper provision of this work.
 2. Beginning work of any Section without reporting unsuitable conditions to Architect constitutes acceptance of conditions by Contractor.
 3. Perform any required removal, repair or replacement of this work caused by unsuitable conditions at no additional cost to Owner.
- C. Piping and ductwork shall be concealed or run behind furring in finished spaces unless otherwise noted to be run exposed.
- D. Horizontal piping and ductwork not run below slabs on grade shall be run as close as possible to underside of roof or floor slab above and parallel to building lines. Maintain maximum headroom in all areas.
- E. Determine possible interference between trades before the work is fabricated or installed. The contractor must coordinate his work to insure that erection will proceed without such interference. Coordination is of paramount importance and no request for additional payment will be considered where such request is based upon interference between trades.
- F. Connections to Existing Work:
1. Install new work and connect to existing work with minimum of interference to existing facilities.
 2. Temporary shutdowns of existing services:
 - a. At no additional charges
 - b. At times not to interfere with normal operation of existing facilities.
 - c. Only with written consent of Owner.
 3. Maintain continuous operation of existing facilities as required with necessary temporary connections between new and existing work.
 4. Restore existing disturbed work to original condition.
- G. Removal, extraction and relocation of existing work.
1. The work includes demolition or removal of all construction indicated or specified. All materials resulting from demolition work, except as indicated or specified otherwise, shall become the property of the Contractor and shall be removed from the site. Rubbish and debris shall be removed from the site daily unless otherwise directed so as to not allow accumulation inside or outside the building. Materials that cannot be removed daily shall be stored in areas specified by the Owner.
 2. Title to all materials and equipment to be demolished, excepting Owner salvage and historical items, is vested in the Contractor upon receipt of notice to proceed. The Owner

Weedsport Addition to Maintenance Section and Roof Replacement, MP 304.2

- will not be responsible for the condition, loss or damage to such property after notice to proceed.
3. The Owner reserves the "Right of First Refusal" on all material for salvage. Material for salvage shall be stored as approved by the Owner. Salvage materials shall be removed from the site before completion of the Contract. Material for salvage shall not be sold on the site.
 4. Property of the Owner: Salvaged items remaining the property of the Owner shall be removed in a manner to prevent damage and packed or crated to protect the items from damage while in storage or during shipment and relocated by the contractor at no cost, to the Owners designated storage facility on the site. Containers shall be properly identified as to contents.
 5. Damaged Items: Items damaged during removal or storage shall be repaired or replaced to match existing.
 6. Disconnect, remove or relocate material, equipment, plumbing fixtures, piping and other work noted and required by removal or changes in existing conditions.
 7. Where existing pipes, conduits and/or ducts which are to remain prevent installation of new work as indicated, relocate, or arrange for relocation, of existing pipes, conduits, and/or ducts.
 8. Provide new material and equipment required for relocated equipment.
 9. Plug or cap active piping or ductwork behind or below finish.
 10. Do not leave long dead-end branches.
 - a. Cap or plug as close as possible to active line.
 11. Remove unused piping, ductwork and equipment.
 12. Dispose of unusable piping, ductwork and material.

1.10 CLEARANCE FROM ELECTRICAL EQUIPMENT

- A. Piping or ductwork:
1. Prohibited, except as noted, in:
 - a. Electric rooms and closets.
 - b. Telephone rooms and closets.
 - c. Elevator machine rooms.
 - d. Electric switchboard room.
 2. Prohibited, except as noted, over or within 5 ft. of:
 - a. Transformers.
 - b. Substations.
 - c. Switchboards.
 - d. Motor control centers.
 - e. Standby power plant.
 - f. Bus ducts.
 - g. Electrical panels.
 3. Drip pans under piping:
 - a. Only where unavoidable and approved.
 - b. 18 gauge galvanized steel.
 - 1) With bituminous paint coating.
 - c. Reinforced and supported.
 - d. Watertight.
 - e. With 1-1/4 inch drain outlet piped to floor drain or service sink.

Weedsport Addition to Maintenance Section and Roof Replacement, MP 304.2

1.11 TEMPORARY FACILITIES

- A. Temporary facilities are not included within this Section.

1.12 SPECIAL TOOLS

- A. Furnish to Owner at completion of work:
1. One set of any special tools required to operate, adjust, dismantle or repair equipment furnished under any section of the Division.
 2. "Special tools": those not normally found in possession of mechanics or maintenance personnel.
 3. One pressure grease gun for each type of grease required.
 - a. With adapters to fit all lubricating fittings on equipment.
 - b. Include lubricant for lubricated plug valves.

1.13 PRODUCT DELIVERY, HANDING AND STORAGE

- A. Provide adequate and secure storage facilities for materials and equipment during the progress of the work.
- B. Contractor shall be responsible for the condition of all materials and equipment employed in the mechanical installation until final acceptance by the Owner. Protect same from any cause whatsoever.
- C. Where necessary, ship in crated sections of size to permit passing through available space.
- D. Ship equipment in original packages, to prevent damaging or entrance of foreign matter.
- E. Handle and ship in accordance with manufacturer's recommendations.
- F. Provide protective coverings during construction.
- G. Replace at no expense to Owner, equipment or material damaged during storage or handling, as directed by Engineer.
- H. Tag all items with weatherproof tag, identifying equipment by name and purchase order number.
- I. Include packing and shipping lists.
- J. Adhere to special requirements as specified in individual sections.

1.14 PROTECTION OF MATERIALS

- A. Protect from damage, water, dust, etc., material, equipment and apparatus provided under this Division, both in storage and installed, until Notice of Completion has been filed.
- B. Provide temporary storage facilities for materials and equipment.

Weedsport Addition to Maintenance Section and Roof Replacement, MP 304.2

- C. Material, equipment or apparatus damaged because of improper storage or protection will be rejected.
 1. Remove from site and provide new, duplicate, material, equipment or apparatus in replacement of that rejected.
- D. Cover motors and other moving machinery to protect from dirt and water during construction. Rotate moving equipment, shafts, bearings, motors etc. to prevent corrosion and to circulate lubricants.
- E. Protect premises and work of other Divisions from damage arising out of installation of work of this Division.
 1. Contractor shall be responsible for the replacement of all damaged or defective work, materials or equipment. Do not install sensitive or delicate equipment until major construction work is completed.
 2. Remove replaced parts from premises.
- F. Make good any damage to the work caused by floods, storms, accidents, acts of God, acts of negligence, strikes, violence or theft up to time of final acceptance by the Owner.
- G. Do not leave any mechanical work in a hazardous condition, even temporarily.

1.15 REVIEW OF CONSTRUCTION

- A. Work may be reviewed at any time by representative of the Engineer.
- B. Advise Architect and Engineer that work is ready for review at following times:
 1. Prior to backfilling buried work.
 2. Prior to concealment of work in walls and above ceilings.
 3. When all requirements of Contract have been completed.
- C. Neither backfill nor conceal work without Engineer's consent.
- D. Maintain on job a set of Specifications and Drawings for use by Engineer's representatives.

1.16 SCHEDULE OF WORK

- A. Arrange work to conform to schedule of construction established or required to comply with Contract Documents.
- B. In scheduling, anticipate means of installing equipment through available openings in structure.
- C. Confirm in writing to Architect and Engineer, within 30 days of signing of contract, anticipated number of days required to perform test, balance, and acceptance testing of mechanical systems.
 1. This phase must occur after completion of mechanical systems, including all control calibration and adjustment, and requires substantial completion of the building, including closure, ceilings, lighting, partitioning, etc.
 2. Submit for approval at this time, names and qualifications of test and balancing agencies to be used.

Weedsport Addition to Maintenance Section and Roof Replacement, MP 304.2

- D. Arrange with Owner schedule for work in each area.
- E. Unless otherwise directed by Owner, perform work during normal working hours.
- F. Work delays:
 - 1. In case noisy work interferes with Owner's operations, Owner may require work to be stopped and performed at some other time, or after normal working hours.

1.17 ACCESS TO MECHANICAL WORK

- A. Access doors in walls and ceilings.
- B. Access Units Fire-Resistance Ratings: Where fire-resistance rating is indicated for construction penetrated by access units, provide UL listed-and-labeled units, except for units which are smaller than minimum size requiring ratings as recognized by governing authority.
- C. Product Data, Access Units: Submit manufacturer's technical data and installation instructions for each type of access door assembly, including setting drawings, templates, instructions and directions for installation of anchorage devices.
- D. Furnish to the general contractor all access doors necessary for access through inaccessible wall or ceiling construction, for installation by the general contractor. Information on the size and location of the subject access doors is to be communicated in writing to the general contractors during the bidding period.

1.18 CONCRETE FOR MECHANICAL WORK

- A. Concrete for Mechanical Work
 - 1. Basins and curbs for mechanical equipment.
 - 2. Mechanical equipment foundations and housekeeping pads.
 - 3. Inertia bases for isolation of mechanical work.
 - 4. Rough grouting in and around mechanical work.
 - 5. Patching concrete cut to accommodate mechanical work.
- B. Quality control testing for concrete is required as work of this section.
- C. Concrete Work Codes and Standards:
 - 1. Comply with governing regulations and, where not otherwise indicated, comply with the following industry standards; whichever is the most stringent in its application to work in each instance.
 - ACI 301 "Specifications for Structural Concrete for Buildings"
 - ACI 311 "Recommended Practice for Concrete Inspection"
 - ACI 318 "Building Code Requirements for Reinforced Concrete"
 - ACI 347 "Recommended Practice for Concrete Form work"
 - ACI 304 "Recommended Practice for Measuring, Mixing, Transporting and Placing Concrete"
 - Concrete Reinforcing Steel Institute's, "Manual of Standard Practice"

Weedsport Addition to Maintenance Section and Roof Replacement, MP 304.2

- D. Submittals: Shop Drawings, Mechanical Concrete Work: Submit shop drawings for structural type concrete work, showing dimensions of formed shapes of concrete; bending, placement, sizes and spacing of reinforcing steel; location of anchors, isolation units, hangers and similar devices to be integrated with concrete work; and piping penetrations, access openings, inlets and other accessories and work to be accommodated by concrete work.
- E. Laboratory Test Reports, Mechanical Concrete Work: Submit laboratory test reports for concrete work materials, and for tested samples of placed concrete (where required as work of this section).

1.19 NOISE REDUCTION

- A. Cooperate in reducing objectionable noise or vibration caused by mechanical systems.
 - 1. To extent of adjustments to specified and installed equipment and appurtenances.
- B. Correct noise problems caused by failure to install work in accordance with Contract Documents.
 - 1. Include labor and materials required as result of such failure.

1.20 CUTTING AND PATCHING

- A. Provide all carpentry, cutting and patching required for proper installation of material and equipment specified.
- B. Do not cut or drill structural members without consent of Architect.

1.21 COORDINATION DRAWINGS

- A. Layout Shop Drawings Required:
 - 1. Prepare layout shop drawings for all areas; minimum 3/8 inch scale.
 - 2. Individual coordinated trade layout drawings are to be prepared for all areas.
 - 3. General Contractor is to assure that each trade has coordinated work with other trades, prior to submittal where submittal is required.
 - a. Include stamp on each submittal indicating that layout shop drawing has been coordinated.
 - 4. No layout shop drawing will be reviewed without stamped and signed coordinated assurance by General Contractor.
 - 5. All changes shall be clearly marked on each submitted layout drawing.
 - 6. Drawings shall show work of all trades including but not limited to'
 - a. Ductwork.
 - b. Piping: All Trades.
 - c. Mechanical Equipment.
 - d. Electrical Equipment.
 - e. Main Electrical conduits and bus ducts.
 - f. Equipment supports and suspension devices.
 - g. Structural and architectural constraints.
 - h. Show location of:
 - 1) 1) Valves
 - 2) 2) Piping specialties

Weedsport Addition to Maintenance Section and Roof Replacement, MP 304.2

- 3) 3) Dampers
 - 4) 4) Access Doors
 - 5) 5) Control and electrical panels
 - 6) 6) Disconnect switches
7. Drawings shall indicate coordination with work in other Divisions that must be incorporated in mechanical spaces, including, but not limited to:
 - a. Elevator equipment.
 - b. Cable trays not furnished under Division 16.
 - c. Computer equipment.
 8. Submission of drawings:
 - a. Prepare reproducible drawings.
 - b. Submit to other trades for review of space allocated to all trades.
 - c. Revise drawings to compensate for requirements of existing conditions and conditions created by other trades.
 - d. Review revisions and other trades.
 - e. Submit one reproducible and one blueline print to Engineer for review.
 9. Final prepared drawings shall show that other trades affected have made reviews and signed, by each trade, at completions of coordination.
 - a. General Contractor
 - b. Include stamp on each submittal indicating that layout shop drawing has been coordinated.
 10. No layout shop drawing will be reviewed without stamped and signed coordination assurance by General Contractor.
- B. Shop Drawings:
1. Layout drawings of mechanical equipment rooms and penthouses showing all related equipment and equipment clearances required by other trades.
 2. Layout drawings of areas in which it may be necessary to deviate substantially from layout shown on the drawings. Minor transitions in ductwork, if required due to job conditions, need not be submitted as long as the duct area is maintained. Show major relocation of ductwork and major changes in size of ducts. Coordinate shop drawings with all trades prior to ductwork fabrication.
 3. Details of intermediate structural steel members required to span main structural steel for the support of ductwork.
 4. Method of attachment of duct hangers to building construction.
 5. Duct material, gage, type of joints and duct reinforcing for each size range, including sketches or SMACNA plate numbers for joints, method of fabrication and reinforcing.

1.22 GUARANTEE

- A. Furnish guarantee covering all work in accordance with general requirements of the contract for minimum period of one year. This personal guarantee shall exist for a period of one (1) year from the date of final acceptance of the work and shall apply to defects in materials and to defective workmanship of any kind.
- B. For factory-assembled equipment and devices on which the manufacturers furnish standard published guarantees as regular trade practice, obtain such guarantees and replace any such equipment that proves defective during the life of these guarantees.

Weedsport Addition to Maintenance Section and Roof Replacement, MP 304.2

- C. Guarantee all work for which materials are furnished, fabricated or field erected by the contractor, all factory-assembled equipment for which no specific manufacturer's guarantee is furnished, and all work in connection with installing manufacturer's guarantee is furnished, and all work in connection with installing manufacturer's guaranteed equipment.
- D. In the event of failure of any work, equipment or device during the life of the guarantee, repair or replace the equipment or defective work. Remove, replace or restore, at no cost to the Owner, any part of the structure or building which may be damaged either as the direct result of the defective work or in the course of the contractor's making replacement of the defective work or materials. Work shall be done at a time and in a manner as to cause no undue inconvenience to the Owner. Provide new materials, equipment, apparatus and labor to replace that determined by Engineer to be defective or faulty.
- E. This guarantee also applies to services including Instructions, Adjusting, Testing, Noise, Balancing, etc.
- F. Additional equipment and material guarantees and warranties may be indicated in other sections. In all cases, the more stringent guarantee or warranty shall be provided.

PART 2 - PRODUCTS

2.1 MATERIALS AND EQUIPMENT QUALITY

- A. Material and equipment furnished under this Division of specification shall be new. Defective or inferior materials must be replaced by contractor at no cost to Owner regardless of the stage of construction. Inferior material shall be defined as material or equipment of a quality or performance less than that specified as determined by the Owner's Representative.
- B. Provide each item of equipment with manufacturer's identification tag which is readily accessible and clearly shows model and size.

2.2 ACCESS TO MECHANICAL WORK

- A. Access Doors:
 - 1. General: Where walls and ceilings must be penetrated for access to mechanical work, access doors shall be provided. Furnish adequate size for intended and necessary access. Furnish doors with UL Fire Rating to match wall or ceiling construction. Furnish manufacturer's complete units, of type recommended for application in indicated substrate construction, in each case, complete with anchorages and hardware.

PART 3 - EXECUTION

3.1 FIELD QUALITY CONTROL

- A. Tests:
 - 1. Perform as specified in individual sections, and as required by authorities having jurisdiction.
 - 2. Duration as noted.

Weedspport Addition to Maintenance Section and Roof Replacement, MP 304.2

- B. Provide required labor, material, equipment, and connections.
- C. Furnish written report and certification those tests have been satisfactorily completed.
- D. Repair or replace defective work, as directed.
- E. Pay for restoring or replacing damaged work due to tests as directed.
- F. Pay for restoring or replacing damaged work of others, due to tests, as directed.

3.2 3.2 ACCESS TO MECHANICAL WORK

- A. Coordinate installation and placement of access doors and panels with contractor for general construction.
- B. Remove or replace panels or frames that are warped, bowed, or otherwise damaged.

END OF SECTION 230001

SECTION 230002 – MECHANICAL AND ELECTRICAL COORDINATION

PART 1 - GENERAL

1.1 WORK INCLUDED

- A. Work Included in This Section: Materials, equipment, fabrication, installation, and tests in conformity with applicable codes and authorities having jurisdiction for the following:
1. Motors.
 2. Factory-wired equipment (FWE).
 3. Factory-wired control panels (FWCP).
 4. Motor controllers where provided as part of mechanical equipment.
 5. Motor controllers where supplied under Division 23 - Mechanical Work.
 6. Disconnects and safety switches for mechanical equipment.
 7. Fuses for equipment provided, and starters and disconnect switches.
 8. Emergency Pushbutton Operator Station.

1.2 RELATED WORK SPECIFIED ELSEWHERE

- A. Division 23 - HVAC Instrumentation and Controls, Motors.
- B. Division 26 - Electrical: Installation and Power Wiring of Motor Controllers.

1.3 REFERENCE STANDARDS

- A. Published specifications standards, tests, or recommended methods of trade, industry or governmental organization as apply to work in this section where cited below:
1. ANSI - American National Standards Institute.
 2. NEMA - National Electrical Manufacturer's Association.
 3. IEEE - Institute of Electrical and Electronic Engineers.

1.4 QUALITY ASSURANCE

- A. All equipment and accessories to be the product of a manufacturer regularly engaged in its manufacture.
- B. Supply all equipment and accessories new and free from defects.
- C. Supply all equipment and accessories in compliance with the applicable standards listed in Article 1.03 of this Section and with all applicable National, State and local codes.
- D. All items of a given-type shall be the products of the same manufacturer.

1.5 DIVISION OF WORK

- A. This section delineates the work required to be performed by Contractors under Divisions 23 and 26.

1.6 WORK REQUIRED UNDER DIVISION 23

- A. Furnish motors, manual and combination starters, pushbutton devices, contactors, disconnect switches, electric thermostats, low voltage transformers, Emergency Break Glass Stations and other electrical devices required for equipment furnished.
- B. Install all items in piping and ductwork such as control valves, aquastats, ductstats, etc.

Weedsport Addition to Maintenance Section and Roof Replacement, MP 304.2

- C. All external wiring of equipment, all temperature control wiring, external wiring of control circuits of magnetic starters, interlocking wiring, boiler wiring, Emergency Break Glass Stations, and mounting of control devices, etc., shall be included under Division 23. All external wiring shall be in conduit. (Unless specifically shown to be provided by the Electrical Contractor)
- D. The Electrical Contractor, under Division 26, shall furnish and install all power wiring and conduit to junction box, to disconnect switch on unit, to motor starters and contactors, and between motor starters and contactors to motor or other load. Electrical Contractor shall be responsible for proper direction of rotation for all three phase equipment. The Electrical Contractor shall mount all starters, disconnects.
- E. Wiring required under Division 23 shall comply with the specifications as described in Division 26.
- F. The Plumbing Contractor, under Division 22, shall provide water and natural gas services to within two (2) feet of HVAC equipment requiring same and terminating with shut-off valves. The HVAC Contractor, under Division 23, shall make final connections to equipment.
- G. Provide disconnect switches or safety switches for equipment. (Unless specifically shown to be provided by the Electrical Contractor, starters and disconnects shown on the electrical drawings are for installation and do not require the Electrical Contractor to furnish units)
- H. Emergency Generator - Exhaust muffler and flexible exhaust connection shall be furnished by the generator manufacturer under Division 26. Installation of the exhaust system including providing piping, insulation and accessories shall be included under Division 23.

1.7 SUBMITTALS

- A. Shop Drawings: Complete wiring diagrams of all power and control connections (standard diagrams will not be accepted). Deliver 2 copies of approved wiring diagrams to the Electric Contractor for installation of wiring and connections required under the Electric Contract.
- B. Product Data for Motor Controllers and Disconnect Switches: Manufacturer's catalog sheets, specifications and installation instructions. Submit enclosure type coordinated for service and location. Submit simultaneously with product data required for motors. Identify each controller for use with corresponding motor. Submit shop drawings and product data in accordance with project requirements.
- C. All warranties shall be delivered as part of the close-out submission.
- D. A receipt shall be delivered as part of the close-out submission that states all required spare parts have been delivered to the owner. This receipt must be signed and dated by the owner.

PART 2 - PRODUCTS**2.1 ACCEPTABLE MANUFACTURERS**

- A. Motor Controllers and Disconnects
 - 1. Square D
 - 2. Allen-Bradley
 - 3. General Electric
 - 4. Cutler-Hammer

Weedsport Addition to Maintenance Section and Roof Replacement, MP 304.2

2.2 MOTOR CONTROLLERS

- A. General: All starters shall be correctly sized to motor connected thereto. Provide one (1) additional auxiliary contact over and above that normally furnished, at least two (2) required. Provide overload heaters for each phase. Coordinate starters and controllers with the temperature control Contractor and sequence of operations.
- B. Minimum Size: The minimum allowable size of single or three phase magnetic motor controller is NEMA size 0.
- C. Enclosures: Unless otherwise indicated furnish NEMA 1 enclosures, except where installed outdoors furnish NEMA 3R enclosures.
- D. Control Power: Furnish control power transformer (maximum control voltage 120 volts) mounted within each magnetic motor controller enclosure.
- E. Local Control Devices: Where indicated, furnish standard duty push buttons or 3-position hand-off-auto selector switch mounted in the controller enclosure.
- F. Pilot Lights: Furnish pilot lights of the neon lamp type mounted in the controller enclosure, green for running, red for not running.
- G. Motor Controller Types:
1. Type A (Full Voltage, Manual, Non-Magnetic):
 - a. Allen-Bradley Co. Bulletin 609 (or Bulletin 600 - single phase, 1 HP or less only).
 - b. General Electric Co. CR-1062 (or CR-101 - single phase, 1 HP or less only).
 - c. Square D Co. Class 2510, Type M (or Class 2510, Type F - single phase, 1 HP or less only).
 - d. Cutler-Hammer. B100 (or MS - single phase, 1 HP or less only).
 2. Type A2 (2 Speed, 2 Winding, Full Voltage, Manual, Non-Magnetic):
 - a. Allen-Bradley Co. Bulletin 609TS (or Bulletin 600 - single phase, 1 HP or less only).
 - b. General Electric Co. CR-1062 (or CR-101 - single phase, 1 HP or less only).
 - c. Square D Co. Class 2512, Type M (or Class 2512, Type F - single phase, 1 HP or less only).
 3. Type B (Full Voltage Magnetic):
 - a. Allen-Bradley Co. Bulletin 709.
 - b. General Electric Co. CR-206.
 - c. Square D Co. Class 8536.
 - d. Cutler-Hammer. ECN05.
 4. Type B-COM (Combination Full Voltage Magnetic/Safety Switch):
 - a. Allen-Bradley Co. Bulletin 712.
 - b. General Electric Co. CR-208.
 - c. Square D Co. Class 8538.
 - d. Cutler-Hammer. ECN16.
 5. Type B2 (2 Speed, 2 Winding, Full Voltage, Magnetic):
 - a. Allen-Bradley Co. Bulletin 715.
 - b. General Electric Co. CR209.
 - c. Square D Co. Class 8810.
 - d. Cutler-Hammer. ECN33.
 6. Type C (Automatic, Reduced Voltage, Magnetic):
 - a. Allen-Bradley Co. Bulletin 746.
 - b. General Electric Co. CR-231.
 - c. Square D Co. Class 8606.

Weedsport Addition to Maintenance Section and Roof Replacement, MP 304.2

- d. Cutler-Hammer. ECA42.
- 7. Type C-COM (Combination Automatic, Reduced Voltage, Magnetic/ Safety Switch):
 - a. Allen-Bradley Co. Bulletin 746C.
 - b. Square D Co. Class 8606.
 - c. Cutler-Hammer. ECA43.
- 8. Type D (Part Winding, Magnetic):
 - a. Allen-Bradley Co. Bulletin 736.
 - b. General Electric Co. CR-230.
 - c. Square D Co. Class 8640.
 - d. Cutler-Hammer. ECA45.

2.3 REMOTE PUSH BUTTON STATIONS

- A. Start-Stop with pilot light in NEMA 1 enclosure unless otherwise indicated.
 - 1. Allen-Bradley Co. Bulletin 800S.
 - 2. General Electric Co. CR-2943.
 - 3. Square D Co. Class 9001.
 - 4. Cutler-Hammer. Class 10250.

2.4 SAFETY SWITCHES

- A. General Electric Co. Type TH; Square D Co. Heavy Duty Series; Cutler-Hammer HD Series; with the following:
 - 1. Fused or unfused as required.
 - 2. Fused switches equipped with fuseholders to accept only the fuses specified in Section 16181 (U.L. Class RK-1, RK-5, L).
 - 3. NEMA 1 enclosure unless otherwise indicated on drawing or required. 3R for devices installed outdoors.
 - 4. Switch rated 240V for 120V, 208V, 240V, circuits; 600 V for 277V, 480V circuits.
 - 5. Switch rated 600V for 277V, 480V circuits.
 - 6. Solid neutral bus when neutral or grounding conductor is included with circuit.
 - 7. Current rating and number of poles as indicated on drawings.

2.5 NAMEPLATES

- A. Phenolic Type: Standard phenolic nameplates with 3/8" minimum size lettering engraved thereon.
- B. Embossed Aluminum: Standard stamped or embossed aluminum tags: Tech Products, Inc., Seton Name Plate Corp.

2.6 EMERGENCY PUSHBUTTON OPERATOR STATION

- A. Acceptable Manufacturer: Square D or equal.
- B. Switch Style: Class 9001, NEMA 4 rated emergency mushroom head pushbutton.
- C. Voltage: 120VAC, 60Hz as required.
- D. Contacts: 20A, 2-NO/2-NC contact.
- E. Operation: Manual.
- F. Normal position: Operator out.
- G. Activated position: Operator in.

Weedsport Addition to Maintenance Section and Roof Replacement, MP 304.2

- H. Reset: Manual, turn to release.
- I. Enclosure: NEMA 4.
- J. Custom Legend Plate
 - 1. "EMERGENCY BOILER SHUTOFF"

PART 3 - EXECUTION

3.1 GENERAL

- A. Equipment shall be connected in a neat and skillful manner. Equipment deliver with terminal boxes that are inadequate shall be equipped with special boxes that suit the conditions by the Mechanical Contractor furnishing the equipment.
- B. In general, rigid conduit or tubing shall be used, but equipment that requires movement or that would transmit vibration to conduit shall be wired with flexible (liquid tight) steel conduit not over 18" long.
- C. All equipment shall be grounded with a green-covered ground wire run inside the conduit and connected to equipment frame on one end and to grounding system on the other end.
- D. All electrical work required in the Mechanical Contract shall conform to the applicable requirements of Division 26 of these Specifications.
- E. The Heating, Ventilating, and Air Conditioning Contractor shall assign all Electrical Work required under his contract to the approved Automatic Temperature Control Contractor, who shall perform this work with qualified electricians employed by that Contractor.
- F. The Mechanical Contractors shall cooperate with the Contractor for Electrical Work in making all necessary tests and in receiving, storing, and setting all motor-driven equipment, electrical devices, and controls furnished and/or installed under these contracts.
- G. Install heaters correlated with full load current of motors provided.
- H. Set overload devices to suit motors provided.

3.2 INSTALLATION

- A. Control Wiring:
 - 1. Provide control wiring and connections.
 - 2. Where control circuit interlocking is required between individually mounted motor controllers, provide a single pole on-off switch in a threaded type box mounted adjacent to motor safety switches which are remote from the control transformer (to enable interlock circuit to be opened when the motor safety switch is opened).
- B. Nameplates: Rivet or bolt the nameplate on the cover of NEMA 1 enclosures. Rivet or bolt and gasket the nameplate on cover of NEMA 3R or NEMA 12 enclosures. Provide phenolic or embossed aluminum nameplates as follows:
 - 1. On each remote control station, indicating motor controlled.
 - 2. On each interlock circuit switch, indicating purpose of switch.
- C. Emergency Pushbutton Operator Station: Wire all switches in series with boiler control branch circuits.

Weedsport Addition to Maintenance Section and Roof Replacement, MP 304.2

3.3 TYPES OF MOTOR CONTROLLERS REQUIRED FOR SINGLE SPEED MOTORS (SYSTEMS UNDER 250 VOLTS)

- A. Single Phase Motors Less than 5 HP - Manually Operated: Type A.
- B. Single Phase Motors Less than 1/2 HP - Automatically Operated: Type A.
- C. Single Phase Motors 1/2 to 5 HP - Automatically Operated: Type B.
- D. Three Phase Squirrel Cage Motors Less than 7-1/2 HP: Type B (B-COM when indicated on drawings).
- E. Three Phase Squirrel Cage Motors 7-1/2 HP and Larger: Type C (C-COM when indicated on drawings).
- F. Three Phase Hermetically Sealed Compressor Motors Less than 7-1/2 HP: Type B.
- G. Three Phase Hermetically Sealed Compressor Motors 7-1/2 HP and Larger: Type D.

3.4 TYPES OF MOTOR CONTROLLERS REQUIRED FOR SINGLE SPEED MOTORS (277/480 VOLT SYSTEM)

- A. Single Phase Motors Less than 5 HP - Manually Operated: Type A.
- B. Single Phase Motors Less than 1 HP - Automatically Operated: Type A.
- C. Single Phase Motors 1 to 5 HP - Automatically Operated: Type B.
- D. Three Phase Squirrel Cage Motors Less than 15 HP: Type B (B-COM when indicated on drawings).
- E. Three Phase Squirrel Cage Motors 15 HP and Larger: Type C (C-COM when indicated on drawings).
- F. Three Phase Hermetically Sealed Compressor Motors Less than 15 HP: Type B.
- G. Three Phase Hermetically Sealed Compressor Motors 15 HP and Larger: Type D.

3.5 TYPES OF MOTOR CONTROLLERS REQUIRED FOR 2 SPEED MOTORS (SYSTEMS UNDER 250 VOLTS)

- A. Single Phase Motors Less than 5 HP - Manually Operated: Type A2.
- B. Single Phase Motors Less than 1/2 HP - Automatically Operated: Type A2.
- C. Single Phase Motors 1/2 to 5 HP - Automatically Operated: Type B2.
- D. Three Phase Squirrel Cage Motors Less than 7-1/2 HP: Type B2.

3.6 TYPES OF MOTOR CONTROLLERS REQUIRED FOR 2 SPEED MOTORS (277/480 VOLT SYSTEM)

- A. Single Phase Motors Less than 5 HP - Manually Operated: Type A2.
- B. Single Phase Motors Less than 1 HP - Automatically Operated: Type A2.
- C. Single Phase Motors 1 to 5 HP - Automatically Operated: Type B2.
- D. Three Phase Squirrel Cage Motors Less than 15 HP: Type B2.

Weedsport Addition to Maintenance Section and Roof Replacement, MP 304.2

3.7 DISCONNECTS

- A. Motor Controllers: Provide safety switch for all motor controllers. Provide combination type starter-disconnect unless otherwise noted on drawings.
- B. Motors: Provide a disconnect switch for all motors. Provide a separate safety switch for motors which are not within sight of the starter.
- C. Provide safety switches for all factory packaged equipment.
- D. Provide NEMA 3R safety switch for all rooftop and outdoor equipment.
- E. Provide unit mounted disconnect switches for all equipment such as unit heaters, fans, unit ventilators, incremental units, etc

3.8 EMERGENCY PUSHBUTTON OPERATOR STATION

- A. Provide Emergency Pushbutton Operator Station at each boiler room exit to de-energize the primary control circuit and to close the main fuel valves to stop the flow of fuel to the burner during an emergency.
- B. Review plans for locations.
- C. Provide all conduit and wiring for interlock of each boiler.

END OF SECTION 230002

SECTION 230513 - COMMON MOTOR REQUIREMENTS FOR HVAC EQUIPMENT

PART 1 - GENERAL

1.1 RELATED DOCUMENTS

- A. Drawings and general provisions of the Contract, including General and Supplementary Conditions and Division 01 Specification Sections, apply to this Section.

1.2 SUMMARY

- A. Section includes general requirements for single-phase and polyphase, general-purpose, horizontal, small and medium, squirrel-cage induction motors for use on ac power systems up to 600 V and installed at equipment manufacturer's factory or shipped separately by equipment manufacturer for field installation.

1.3 COORDINATION

- A. Coordinate features of motors, installed units, and accessory devices to be compatible with the following:
 - 1. Motor controllers.
 - 2. Torque, speed, and horsepower requirements of the load.
 - 3. Ratings and characteristics of supply circuit and required control sequence.
 - 4. Ambient and environmental conditions of installation location.

PART 2 - PRODUCTS

2.1 GENERAL MOTOR REQUIREMENTS

- A. Comply with NEMA MG 1 unless otherwise indicated.
- B. Comply with IEEE 841 for severe-duty motors.

2.2 MOTOR CHARACTERISTICS

- A. Duty: Continuous duty at ambient temperature of 40 deg C and at altitude of 3300 feet above sea level.
- B. Capacity and Torque Characteristics: Sufficient to start, accelerate, and operate connected loads at designated speeds, at installed altitude and environment, with indicated operating sequence, and without exceeding nameplate ratings or considering service factor.

2.3 POLYPHASE MOTORS

- A. Description: NEMA MG 1, Design B, medium induction motor.
- B. Efficiency: Premium energy efficient, as defined in NEMA MG 1.
- C. Service Factor: 1.15.
- D. Multispeed Motors: Variable torque.
 - 1. For motors with 2:1 speed ratio, consequent pole, single winding.
 - 2. For motors with other than 2:1 speed ratio, separate winding for each speed.
- E. Multispeed Motors: Separate winding for each speed.
- F. Rotor: Random-wound, squirrel cage.

Weedsport Addition to Maintenance Section and Roof Replacement, MP 304.2

- G. Bearings: Regreasable, shielded, antifriction ball bearings suitable for radial and thrust loading.
- H. Temperature Rise: Match insulation rating.
- I. Insulation: Class F.
- J. Code Letter Designation:
 1. Motors 15 HP and Larger: NEMA starting Code F or Code G.
 2. Motors Smaller than 15 HP: Manufacturer's standard starting characteristic.
- K. Enclosure Material: Cast iron for motor frame sizes 324T and larger; rolled steel for motor frame sizes smaller than 324T.

2.4 POLYPHASE MOTORS WITH ADDITIONAL REQUIREMENTS

- A. Motors Used with Reduced-Voltage and Multispeed Controllers: Match wiring connection requirements for controller with required motor leads. Provide terminals in motor terminal box, suited to control method.
- B. Motors Used with Variable Frequency Controllers: Ratings, characteristics, and features coordinated with and approved by controller manufacturer.
 1. Windings: Copper magnet wire with moisture-resistant insulation varnish, designed and tested to resist transient spikes, high frequencies, and short time rise pulses produced by pulse-width modulated inverters.
 2. Energy- and Premium-Efficient Motors: Class B temperature rise; Class F insulation.
 3. Thermal Protection: Comply with NEMA MG 1 requirements for thermally protected motors.
- C. Severe-Duty Motors: Comply with IEEE 841, with 1.15 minimum service factor.

2.5 SINGLE-PHASE MOTORS

- A. Motors larger than 1/20 hp shall be one of the following, to suit starting torque and requirements of specific motor application:
 1. Permanent-split capacitor.
 2. Split phase.
 3. Capacitor start, inductor run.
 4. Capacitor start, capacitor run.
- B. Multispeed Motors: Variable-torque, permanent-split-capacitor type.
- C. Bearings: Prelubricated, antifriction ball bearings or sleeve bearings suitable for radial and thrust loading.
- D. Motors 1/20 HP and Smaller: Shaded-pole type.
- E. Thermal Protection: Internal protection to automatically open power supply circuit to motor when winding temperature exceeds a safe value calibrated to temperature rating of motor insulation. Thermal-protection device shall automatically reset when motor temperature returns to normal range.

PART 3 - EXECUTION (Not Applicable)

END OF SECTION 230513

SECTION 230553 - IDENTIFICATION FOR HVAC PIPING AND EQUIPMENT

PART 1 - GENERAL

1.1 RELATED DOCUMENTS

- A. Drawings and general provisions of the Contract, including General and Supplementary Conditions and Division 01 Specification Sections, apply to this Section.

1.2 SUMMARY

- A. Section Includes:
 - 1. Equipment labels.
 - 2. Warning signs and labels.
 - 3. Pipe labels.
 - 4. Duct labels.
 - 5. Stencils.
 - 6. Valve tags.
 - 7. Warning tags.

1.3 ACTION SUBMITTALS

- A. Product Data: For each type of product indicated.
- B. Equipment Label Schedule: Include a listing of all equipment to be labeled with the proposed content for each label.
- C. Valve numbering scheme.
- D. Valve Schedules: For each piping system to include in maintenance manuals.

1.4 COORDINATION

- A. Coordinate installation of identifying devices with completion of covering and painting of surfaces where devices are to be applied.
- B. Coordinate installation of identifying devices with locations of access panels and doors.
- C. Install identifying devices before installing acoustical ceilings and similar concealment.

PART 2 - PRODUCTS

2.1 EQUIPMENT LABELS

- A. Metal Labels for Equipment:
 - 1. Material and Thickness: Aluminum, 0.032-inch minimum thickness, and having predrilled or stamped holes for attachment hardware.
 - 2. Minimum Label Size: Length and width vary for required label content, but not less than 2-1/2 by 3/4 inch.
 - 3. Minimum Letter Size: 1/4 inch for name of units if viewing distance is less than 24 inches, 1/2 inch for viewing distances up to 72 inches, and proportionately larger lettering for greater viewing distances. Include secondary lettering two-thirds to three-fourths the size of principal lettering.
 - 4. Fasteners: Stainless-steel rivets or self-tapping screws.
 - 5. Adhesive: Contact-type permanent adhesive, compatible with label and with substrate.

Weedsport Addition to Maintenance Section and Roof Replacement, MP 304.2

- B. Plastic Labels for Equipment:
1. Material and Thickness: Multilayer, multicolor, plastic labels for mechanical engraving, 1/8 inch thick, and having predrilled holes for attachment hardware.
 2. Letter Color: White.
 3. Background Color: Black.
 4. Maximum Temperature: Able to withstand temperatures up to 160 deg F.
 5. Minimum Label Size: Length and width vary for required label content, but not less than 2-1/2 by 3/4 inch.
 6. Minimum Letter Size: 1/4 inch for name of units if viewing distance is less than 24 inches, 1/2 inch for viewing distances up to 72 inches, and proportionately larger lettering for greater viewing distances. Include secondary lettering two-thirds to three-fourths the size of principal lettering.
 7. Fasteners: Stainless-steel rivets or self-tapping screws.
 8. Adhesive: Contact-type permanent adhesive, compatible with label and with substrate.
- C. Label Content: Include equipment's Drawing designation or unique equipment number, Drawing numbers where equipment is indicated (plans, details, and schedules), plus the Specification Section number and title where equipment is specified.
- D. Equipment Label Schedule: For each item of equipment to be labeled, on 8-1/2-by-11-inch bond paper. Tabulate equipment identification number and identify Drawing numbers where equipment is indicated (plans, details, and schedules), plus the Specification Section number and title where equipment is specified. Equipment schedule shall be included in operation and maintenance data.

2.2 WARNING SIGNS AND LABELS

- A. Material and Thickness: Multilayer, multicolor, plastic labels for mechanical engraving, 1/8 inch thick, and having predrilled holes for attachment hardware.
- B. Letter Color: Black.
- C. Background Color: Red.
- D. Maximum Temperature: Able to withstand temperatures up to 160 deg F.
- E. Minimum Label Size: Length and width vary for required label content, but not less than 2-1/2 by 3/4 inch.
- F. Minimum Letter Size: 1/4 inch for name of units if viewing distance is less than 24 inches, 1/2 inch for viewing distances up to 72 inches, and proportionately larger lettering for greater viewing distances. Include secondary lettering two-thirds to three-fourths the size of principal lettering.
- G. Fasteners: Stainless-steel rivets or self-tapping screws.
- H. Adhesive: Contact-type permanent adhesive, compatible with label and with substrate.
- I. Label Content: Include caution and warning information, plus emergency notification instructions.

2.3 PIPE LABELS

- A. General Requirements for Manufactured Pipe Labels: Preprinted, color-coded, with lettering indicating service, and showing flow direction.

Weedsport Addition to Maintenance Section and Roof Replacement, MP 304.2

- B. Pretensioned Pipe Labels: Precoiled, semirigid plastic formed to cover full circumference of pipe and to attach to pipe without fasteners or adhesive.
- C. Self-Adhesive Pipe Labels: Printed plastic with contact-type, permanent-adhesive backing.
- D. Pipe Label Contents: Include identification of piping service using same designations or abbreviations as used on Drawings, pipe size, and an arrow indicating flow direction.
 - 1. Flow-Direction Arrows: Integral with piping system service lettering to accommodate both directions, or as separate unit on each pipe label to indicate flow direction.
 - 2. Lettering Size: At least 1-1/2 incheshigh.

2.4 DUCT LABELS

- A. General Requirements for Manufactured Duct Labels: Preprinted, color-coded, with lettering indicating service, and showing flow direction.
- B. Self-Adhesive Duct Labels: Printed plastic with contact-type, permanent-adhesive backing.
- C. Duct Label Contents: Include identification of duct service using same designations or abbreviations as used on Drawings, duct size, and an arrow indicating flow direction.
 - 1. Flow-Direction Arrows: Integral with duct system service lettering to accommodate both directions, or as separate unit on each duct label to indicate flow direction.
 - 2. Lettering Size: At least 1-1/2 incheshigh.

2.5 STENCILS

- A. Stencils: Prepared with letter sizes according to ASME A13.1 for piping; minimum letter height of 1-1/4 inches for ducts; and minimum letter height of 3/4 inch for access panel and door labels, equipment labels, and similar operational instructions.
 - 1. Stencil Material: Fiberboard or metal.
 - 2. Stencil Paint: Exterior, gloss, acrylic enamel black unless otherwise indicated. Paint may be in pressurized spray-can form.
 - 3. Identification Paint: Exterior, acrylic enamel in colors according to ASME A13.1 unless otherwise indicated.

2.6 VALVE TAGS

- A. Valve Tags: Stamped or engraved with 1/4-inch letters for piping system abbreviation and 1/2-inch numbers.
 - 1. Tag Material: Brass, 0.032-inch minimum thickness, and having predrilled or stamped holes for attachment hardware.
 - 2. Fasteners: Brass wire-link or beaded chain; or S-hook.
- B. Valve Schedules: For each piping system, on 8-1/2-by-11-inch bond paper. Tabulate valve number, piping system, system abbreviation (as shown on valve tag), location of valve (room or space), normal-operating position (open, closed, or modulating), and variations for identification. Mark valves for emergency shutoff and similar special uses.
 - 1. Valve-tag schedule shall be included in operation and maintenance data.

2.7 WARNING TAGS

- A. Warning Tags: Preprinted or partially preprinted, accident-prevention tags, of plasticized card stock with matte finish suitable for writing.
 - 1. Size: Approximately 4 by 7 inches.
 - 2. Fasteners: Brass grommet and wire.

Weedsport Addition to Maintenance Section and Roof Replacement, MP 304.2

3. Nomenclature: Large-size primary caption such as "DANGER," "CAUTION," or "DO NOT OPERATE."
4. Color: Yellow background with black lettering.

PART 3 - EXECUTION

3.1 PREPARATION

- A. Clean piping and equipment surfaces of substances that could impair bond of identification devices, including dirt, oil, grease, release agents, and incompatible primers, paints, and encapsulants.

3.2 EQUIPMENT LABEL INSTALLATION

- A. Install or permanently fasten labels on each major item of mechanical equipment.
- B. Locate equipment labels where accessible and visible.

3.3 PIPE LABEL INSTALLATION

- A. Stenciled Pipe Label Option: Stenciled labels may be provided instead of manufactured pipe labels, at Installer's option. Install stenciled pipe labels with painted, color-coded bands or rectangles, complying with ASME A13.1, on each piping system.
 1. Identification Paint: Use for contrasting background.
 2. Stencil Paint: Use for pipe marking.
- B. Locate pipe labels where piping is exposed or above accessible ceilings in finished spaces; machine rooms; accessible maintenance spaces such as shafts, tunnels, and plenums; and exterior exposed locations as follows:
 1. Near each valve and control device.
 2. Near each branch connection, excluding short takeoffs for fixtures and terminal units. Where flow pattern is not obvious, mark each pipe at branch.
 3. Near penetrations through walls, floors, ceilings, and inaccessible enclosures.
 4. At access doors, manholes, and similar access points that permit view of concealed piping.
 5. Near major equipment items and other points of origination and termination.
 6. Spaced at maximum intervals of 50 feet along each run. Reduce intervals to 25 feet in areas of congested piping and equipment.
 7. On piping above removable acoustical ceilings. Omit intermediately spaced labels.

3.4 DUCT LABEL INSTALLATION

- A. Install self-adhesive duct labels with permanent adhesive on air ducts in the following color codes:
 1. Blue: For cold-air supply ducts.
 2. Green: For exhaust- and return-air ducts.
- B. Stenciled Duct Label Option: Stenciled labels, showing service and flow direction, may be provided instead of plastic-laminated duct labels, at Installer's option, if lettering larger than 1 inch high is needed for proper identification because of distance from normal location of required identification.

Weedsport Addition to Maintenance Section and Roof Replacement, MP 304.2

- C. Locate labels near points where ducts enter into concealed spaces and at maximum intervals of 50 feet in each space where ducts are exposed or concealed by removable ceiling system.

3.5 VALVE-TAG INSTALLATION

- A. Install tags on valves and control devices in piping systems, except check valves; valves within factory-fabricated equipment units; shutoff valves; faucets; convenience and lawn-watering hose connections; and HVAC terminal devices and similar roughing-in connections of end-use fixtures and units. List tagged valves in a valve schedule.
- B. Valve-Tag Application Schedule: Tag valves according to size, shape, and color scheme and with captions similar to those indicated in the following subparagraphs:
 - 1. Valve-Tag Size and Shape:
 - a. All services: 1-1/2 inches round.

3.6 WARNING-TAG INSTALLATION

- A. Write required message on, and attach warning tags to, equipment and other items where required.

END OF SECTION 230553

SECTION 230593 - TESTING, ADJUSTING, AND BALANCING FOR HVAC

PART 1 - GENERAL

1.1 RELATED DOCUMENTS

- A. Drawings and general provisions of the Contract, including General and Supplementary Conditions and Division 01 Specification Sections, apply to this Section.

1.2 SUMMARY

- A. Section Includes:
 - 1. Balancing Air Systems:
 - a. Constant-volume air systems.
 - b. Dual-duct systems.
 - c. Variable-air-volume systems.
 - d. Multizone systems.
 - e. Induction-unit systems.

1.3 DEFINITIONS

- A. AABC: Associated Air Balance Council.
- B. NEBB: National Environmental Balancing Bureau.
- C. TAB: Testing, adjusting, and balancing.

1.4 INFORMATIONAL SUBMITTALS

- A. Qualification Data: Within 45 days of Contractor's Notice to Proceed, submit documentation that the TAB contractor and this Project's TAB team members meet the qualifications specified in "Quality Assurance" Article.
- B. Contract Documents Examination Report: Within 30 days of Contractor's Notice to Proceed, submit the Contract Documents review report as specified in Part 3.
- C. Certified TAB reports.
- D. Sample report forms.
- E. Instrument calibration reports, to include the following:
 - 1. Instrument type and make.
 - 2. Serial number.
 - 3. Application.
 - 4. Dates of use.
 - 5. Dates of calibration.

1.5 QUALITY ASSURANCE

- A. TAB Contractor Qualifications: Engage a TAB entity certified by AABC or NEBB.
 - 1. TAB Field Supervisor: Employee of the TAB contractor and certified by AABC or NEBB.
 - 2. TAB Technician: Employee of the TAB contractor and who is certified by AABC or NEBB as a TAB technician.
- B. Certify TAB field data reports and perform the following:

Weedsport Addition to Maintenance Section and Roof Replacement, MP 304.2

1. Review field data reports to validate accuracy of data and to prepare certified TAB reports.
 2. Certify that the TAB team complied with the approved TAB plan and the procedures specified and referenced in this Specification.
- C. TAB Report Forms: Use standard TAB contractor's forms approved by Engineer.
- D. Instrumentation Type, Quantity, Accuracy, and Calibration: As described in ASHRAE 111, Section 5, "Instrumentation."
- E. ASHRAE Compliance: Applicable requirements in ASHRAE 62.1, Section 7.2.2 - "Air Balancing."
- F. ASHRAE/IESNA Compliance: Applicable requirements in ASHRAE/IESNA 90.1, Section 6.7.2.3 - "System Balancing."

1.6 PROJECT CONDITIONS

- A. Partial Owner Occupancy: Owner may occupy completed areas of building before Substantial Completion. Cooperate with Owner during TAB operations to minimize conflicts with Owner's operations.

1.7 COORDINATION

- A. Perform TAB after leakage and pressure tests on air and water distribution systems have been satisfactorily completed.

PART 2 - PRODUCTS (Not Applicable)

PART 3 - EXECUTION

3.1 EXAMINATION

- A. Examine the Contract Documents to become familiar with Project requirements and to discover conditions in systems' designs that may preclude proper TAB of systems and equipment.
- B. Examine systems for installed balancing devices, such as test ports, gage cocks, thermometer wells, flow-control devices, balancing valves and fittings, and manual volume dampers. Verify that locations of these balancing devices are accessible.
- C. Examine the approved submittals for HVAC systems and equipment.
- D. Examine design data including HVAC system descriptions, statements of design assumptions for environmental conditions and systems' output, and statements of philosophies and assumptions about HVAC system and equipment controls.
- E. Examine ceiling plenums and underfloor air plenums used for supply, return, or relief air to verify that they meet the leakage class of connected ducts as specified in Section 233113 "Metal Ducts" and are properly separated from adjacent areas. Verify that penetrations in plenum walls are sealed and fire-stopped if required.
- F. Examine equipment performance data including fan and pump curves.
 1. Relate performance data to Project conditions and requirements, including system effects that can create undesired or unpredicted conditions that cause reduced capacities in all or part of a system.

Weedsport Addition to Maintenance Section and Roof Replacement, MP 304.2

2. Calculate system-effect factors to reduce performance ratings of HVAC equipment when installed under conditions different from the conditions used to rate equipment performance. To calculate system effects for air systems, use tables and charts found in AMCA 201, "Fans and Systems," or in SMACNA's "HVAC Systems - Duct Design." Compare results with the design data and installed conditions.
- G. Examine system and equipment installations and verify that field quality-control testing, cleaning, and adjusting specified in individual Sections have been performed.
- H. Examine test reports specified in individual system and equipment Sections.
- I. Examine HVAC equipment and filters and verify that bearings are greased, belts are aligned and tight, and equipment with functioning controls is ready for operation.
- J. Examine terminal units, such as variable-air-volume boxes, and verify that they are accessible and their controls are connected and functioning.
- K. Examine strainers. Verify that startup screens are replaced by permanent screens with indicated perforations.
- L. Examine three-way valves for proper installation for their intended function of diverting or mixing fluid flows.
- M. Examine heat-transfer coils for correct piping connections and for clean and straight fins.
- N. Examine system pumps to ensure absence of entrained air in the suction piping.
- O. Examine operating safety interlocks and controls on HVAC equipment.
- P. Report deficiencies discovered before and during performance of TAB procedures. Observe and record system reactions to changes in conditions. Record default set points if different from indicated values.

3.2 PREPARATION

- A. Complete system-readiness checks and prepare reports. Verify the following:
 1. Permanent electrical-power wiring is complete.
 2. Hydronic systems are filled, clean, and free of air.
 3. Automatic temperature-control systems are operational.
 4. Equipment and duct access doors are securely closed.
 5. Balance, smoke, and fire dampers are open.
 6. Isolating and balancing valves are open and control valves are operational.
 7. Ceilings are installed in critical areas where air-pattern adjustments are required and access to balancing devices is provided.
 8. Windows and doors can be closed so indicated conditions for system operations can be met.

3.3 GENERAL PROCEDURES FOR TESTING AND BALANCING

- A. Perform testing and balancing procedures on each system according to the procedures contained in AABC's "National Standards for Total System Balance", ASHRAE 111, or NEBB's "Procedural Standards for Testing, Adjusting, and Balancing of Environmental Systems" and in this Section.
 1. Comply with requirements in ASHRAE 62.1, Section 7.2.2 - "Air Balancing."

Weedsport Addition to Maintenance Section and Roof Replacement, MP 304.2

- B. Cut insulation, ducts, pipes, and equipment cabinets for installation of test probes to the minimum extent necessary for TAB procedures.
 - 1. After testing and balancing, patch probe holes in ducts with same material and thickness as used to construct ducts.
 - 2. After testing and balancing, install test ports and duct access doors that comply with requirements in Section 233300 "Air Duct Accessories."
 - 3. Install and join new insulation that matches removed materials. Restore insulation, coverings, vapor barrier, and finish according to Section 230713 "Duct Insulation".
- C. Mark equipment and balancing devices, including damper-control positions, valve position indicators, fan-speed-control levers, and similar controls and devices, with paint or other suitable, permanent identification material to show final settings.
- D. Take and report testing and balancing measurements in inch-pound (IP) units.

3.4 GENERAL PROCEDURES FOR BALANCING AIR SYSTEMS

- A. Prepare test reports for both fans and outlets. Obtain manufacturer's outlet factors and recommended testing procedures. Crosscheck the summation of required outlet volumes with required fan volumes.
- B. Prepare schematic diagrams of systems' "as-built" duct layouts.
- C. For variable-air-volume systems, develop a plan to simulate diversity.
- D. Determine the best locations in main and branch ducts for accurate duct-airflow measurements.
- E. Check airflow patterns from the outdoor-air louvers and dampers and the return- and exhaust-air dampers through the supply-fan discharge and mixing dampers.
- F. Locate start-stop and disconnect switches, electrical interlocks, and motor starters.
- G. Verify that motor starters are equipped with properly sized thermal protection.
- H. Check dampers for proper position to achieve desired airflow path.
- I. Check for airflow blockages.
- J. Check condensate drains for proper connections and functioning.
- K. Check for proper sealing of air-handling-unit components.
- L. Verify that air duct system is sealed as specified in Section 233113 "Metal Ducts."

3.5 PROCEDURES FOR CONSTANT-VOLUME AIR SYSTEMS

- A. Adjust fans to deliver total indicated airflows within the maximum allowable fan speed listed by fan manufacturer.
 - 1. Measure total airflow.
 - a. Where sufficient space in ducts is unavailable for Pitot-tube traverse measurements, measure airflow at terminal outlets and inlets and calculate the total airflow.
 - 2. Measure fan static pressures as follows to determine actual static pressure:
 - a. Measure outlet static pressure as far downstream from the fan as practical and upstream from restrictions in ducts such as elbows and transitions.
 - b. Measure static pressure directly at the fan outlet or through the flexible connection.

Weedsport Addition to Maintenance Section and Roof Replacement, MP 304.2

- c. Measure inlet static pressure of single-inlet fans in the inlet duct as near the fan as possible, upstream from the flexible connection, and downstream from duct restrictions.
- d. Measure inlet static pressure of double-inlet fans through the wall of the plenum that houses the fan.
- 3. Measure static pressure across each component that makes up an air-handling unit, rooftop unit, and other air-handling and -treating equipment.
 - a. Report the cleanliness status of filters and the time static pressures are measured.
- 4. Measure static pressures entering and leaving other devices, such as sound traps, heat-recovery equipment, and air washers, under final balanced conditions.
- 5. Review Record Documents to determine variations in design static pressures versus actual static pressures. Calculate actual system-effect factors. Recommend adjustments to accommodate actual conditions.
- 6. Obtain approval from Engineer for adjustment of fan speed higher or lower than indicated speed. Comply with requirements in HVAC Sections for air-handling units for adjustment of fans, belts, and pulley sizes to achieve indicated air-handling-unit performance.
- 7. Do not make fan-speed adjustments that result in motor overload. Consult equipment manufacturers about fan-speed safety factors. Modulate dampers and measure fan-motor amperage to ensure that no overload will occur. Measure amperage in full-cooling, full-heating, economizer, and any other operating mode to determine the maximum required brake horsepower.
- B. Adjust volume dampers for main duct, submain ducts, and major branch ducts to indicated airflows within specified tolerances.
 - 1. Measure airflow of submain and branch ducts.
 - a. Where sufficient space in submain and branch ducts is unavailable for Pitot-tube traverse measurements, measure airflow at terminal outlets and inlets and calculate the total airflow for that zone.
 - 2. Measure static pressure at a point downstream from the balancing damper, and adjust volume dampers until the proper static pressure is achieved.
 - 3. Remeasure each submain and branch duct after all have been adjusted. Continue to adjust submain and branch ducts to indicated airflows within specified tolerances.
- C. Measure air outlets and inlets without making adjustments.
 - 1. Measure terminal outlets using a direct-reading hood or outlet manufacturer's written instructions and calculating factors.
- D. Adjust air outlets and inlets for each space to indicated airflows within specified tolerances of indicated values. Make adjustments using branch volume dampers rather than extractors and the dampers at air terminals.
 - 1. Adjust each outlet in same room or space to within specified tolerances of indicated quantities without generating noise levels above the limitations prescribed by the Contract Documents.
 - 2. Adjust patterns of adjustable outlets for proper distribution without drafts.

3.6 PROCEDURES FOR VARIABLE-AIR-VOLUME SYSTEMS

- A. Compensating for Diversity: When the total airflow of all terminal units is more than the indicated airflow of the fan, place a selected number of terminal units at a minimum set-point airflow with the remainder at maximum-airflow condition until the total airflow of the terminal

Weedsport Addition to Maintenance Section and Roof Replacement, MP 304.2

units equals the indicated airflow of the fan. Select the reduced-airflow terminal units so they are distributed evenly among the branch ducts.

- B. Pressure-Independent, Variable-Air-Volume Systems: After the fan systems have been adjusted, adjust the variable-air-volume systems as follows:
1. Set outdoor-air dampers at minimum, and set return- and exhaust-air dampers at a position that simulates full-cooling load.
 2. Select the terminal unit that is most critical to the supply-fan airflow and static pressure. Measure static pressure. Adjust system static pressure so the entering static pressure for the critical terminal unit is not less than the sum of the terminal-unit manufacturer's recommended minimum inlet static pressure plus the static pressure needed to overcome terminal-unit discharge system losses.
 3. Measure total system airflow. Adjust to within indicated airflow.
 4. Set terminal units at maximum airflow and adjust controller or regulator to deliver the designed maximum airflow. Use terminal-unit manufacturer's written instructions to make this adjustment. When total airflow is correct, balance the air outlets downstream from terminal units the same as described for constant-volume air systems.
 5. Set terminal units at minimum airflow and adjust controller or regulator to deliver the designed minimum airflow. Check air outlets for a proportional reduction in airflow the same as described for constant-volume air systems.
 - a. If air outlets are out of balance at minimum airflow, report the condition but leave outlets balanced for maximum airflow.
 6. Remeasure the return airflow to the fan while operating at maximum return airflow and minimum outdoor airflow.
 - a. Adjust the fan and balance the return-air ducts and inlets the same as described for constant-volume air systems.
 7. Measure static pressure at the most critical terminal unit and adjust the static-pressure controller at the main supply-air sensing station to ensure that adequate static pressure is maintained at the most critical unit.
 8. Record final fan-performance data.
- C. Pressure-Dependent, Variable-Air-Volume Systems without Diversity: After the fan systems have been adjusted, adjust the variable-air-volume systems as follows:
1. Balance variable-air-volume systems the same as described for constant-volume air systems.
 2. Set terminal units and supply fan at full-airflow condition.
 3. Adjust inlet dampers of each terminal unit to indicated airflow and verify operation of the static-pressure controller. When total airflow is correct, balance the air outlets downstream from terminal units the same as described for constant-volume air systems.
 4. Readjust fan airflow for final maximum readings.
 5. Measure operating static pressure at the sensor that controls the supply fan if one is installed, and verify operation of the static-pressure controller.
 6. Set supply fan at minimum airflow if minimum airflow is indicated. Measure static pressure to verify that it is being maintained by the controller.
 7. Set terminal units at minimum airflow and adjust controller or regulator to deliver the designed minimum airflow. Check air outlets for a proportional reduction in airflow the same as described for constant-volume air systems.
 - a. If air outlets are out of balance at minimum airflow, report the condition but leave the outlets balanced for maximum airflow.

Weedsport Addition to Maintenance Section and Roof Replacement, MP 304.2

8. Measure the return airflow to the fan while operating at maximum return airflow and minimum outdoor airflow.
 - a. Adjust the fan and balance the return-air ducts and inlets the same as described for constant-volume air systems.
- D. Pressure-Dependent, Variable-Air-Volume Systems with Diversity: After the fan systems have been adjusted, adjust the variable-air-volume systems as follows:
1. Set system at maximum indicated airflow by setting the required number of terminal units at minimum airflow. Select the reduced-airflow terminal units so they are distributed evenly among the branch ducts.
 2. Adjust supply fan to maximum indicated airflow with the variable-airflow controller set at maximum airflow.
 3. Set terminal units at full-airflow condition.
 4. Adjust terminal units starting at the supply-fan end of the system and continuing progressively to the end of the system. Adjust inlet dampers of each terminal unit to indicated airflow. When total airflow is correct, balance the air outlets downstream from terminal units the same as described for constant-volume air systems.
 5. Adjust terminal units for minimum airflow.
 6. Measure static pressure at the sensor.
 7. Measure the return airflow to the fan while operating at maximum return airflow and minimum outdoor airflow. Adjust the fan and balance the return-air ducts and inlets the same as described for constant-volume air systems.

3.7 PROCEDURES FOR MOTORS

- A. Motors, 1/2 HP and Larger: Test at final balanced conditions and record the following data:
1. Manufacturer's name, model number, and serial number.
 2. Motor horsepower rating.
 3. Motor rpm.
 4. Efficiency rating.
 5. Nameplate and measured voltage, each phase.
 6. Nameplate and measured amperage, each phase.
 7. Starter thermal-protection-element rating.
- B. Motors Driven by Variable-Frequency Controllers: Test for proper operation at speeds varying from minimum to maximum. Test the manual bypass of the controller to prove proper operation. Record observations including name of controller manufacturer, model number, serial number, and nameplate data.

3.8 PROCEDURES FOR CONDENSING UNITS

- A. Verify proper rotation of fans.
- B. Measure entering- and leaving-air temperatures.
- C. Record compressor data.

3.9 PROCEDURES FOR TESTING, ADJUSTING, AND BALANCING EXISTING SYSTEMS

- A. Perform a preconstruction inspection of existing equipment that is to remain and be reused.
1. Measure and record the operating speed, airflow, and static pressure of each fan.

Weedsport Addition to Maintenance Section and Roof Replacement, MP 304.2

2. Measure motor voltage and amperage. Compare the values to motor nameplate information.
 3. Check the refrigerant charge.
 4. Check the condition of filters.
 5. Check the condition of coils.
 6. Check the operation of the drain pan and condensate-drain trap.
 7. Check bearings and other lubricated parts for proper lubrication.
 8. Report on the operating condition of the equipment and the results of the measurements taken. Report deficiencies.
- B. Before performing testing and balancing of existing systems, inspect existing equipment that is to remain and be reused to verify that existing equipment has been cleaned and refurbished. Verify the following:
1. New filters are installed.
 2. Coils are clean and fins combed.
 3. Drain pans are clean.
 4. Fans are clean.
 5. Bearings and other parts are properly lubricated.
 6. Deficiencies noted in the preconstruction report are corrected.
- C. Perform testing and balancing of existing systems to the extent that existing systems are affected by the renovation work.
1. Compare the indicated airflow of the renovated work to the measured fan airflows, and determine the new fan speed and the face velocity of filters and coils.
 2. Verify that the indicated airflows of the renovated work result in filter and coil face velocities and fan speeds that are within the acceptable limits defined by equipment manufacturer.
 3. If calculations increase or decrease the air flow rates and water flow rates by more than 5 percent, make equipment adjustments to achieve the calculated rates. If increase or decrease is 5 percent or less, equipment adjustments are not required.
 4. Balance each air outlet.

3.10 TOLERANCES

- A. Set HVAC system's air flow rates and water flow rates within the following tolerances:
1. Supply, Return, and Exhaust Fans and Equipment with Fans: Plus or minus 10 percent.
 2. Air Outlets and Inlets: Plus or minus 10 percent.
 3. Heating-Water Flow Rate: Plus or minus 10 percent.
 4. Cooling-Water Flow Rate: Plus or minus 10 percent.

3.11 REPORTING

- A. Initial Construction-Phase Report: Based on examination of the Contract Documents as specified in "Examination" Article, prepare a report on the adequacy of design for systems' balancing devices. Recommend changes and additions to systems' balancing devices to facilitate proper performance measuring and balancing. Recommend changes and additions to HVAC systems and general construction to allow access for performance measuring and balancing devices.
- B. Status Reports: Prepare biweekly progress reports to describe completed procedures, procedures in progress, and scheduled procedures. Include a list of deficiencies and problems found in systems being tested and balanced. Prepare a separate report for each system and each building floor for systems serving multiple floors.

3.12 FINAL REPORT

- A. General: Prepare a certified written report; tabulate and divide the report into separate sections for tested systems and balanced systems.
1. Include a certification sheet at the front of the report's binder, signed and sealed by the certified testing and balancing engineer.
 2. Include a list of instruments used for procedures, along with proof of calibration.
- B. Final Report Contents: In addition to certified field-report data, include the following:
1. Pump curves.
 2. Fan curves.
 3. Manufacturers' test data.
 4. Field test reports prepared by system and equipment installers.
 5. Other information relative to equipment performance; do not include Shop Drawings and product data.
- C. General Report Data: In addition to form titles and entries, include the following data:
1. Title page.
 2. Name and address of the TAB contractor.
 3. Project name.
 4. Project location.
 5. Architect's name and address.
 6. Engineer's name and address.
 7. Contractor's name and address.
 8. Report date.
 9. Signature of TAB supervisor who certifies the report.
 10. Table of Contents with the total number of pages defined for each section of the report. Number each page in the report.
 11. Summary of contents including the following:
 - a. Indicated versus final performance.
 - b. Notable characteristics of systems.
 - c. Description of system operation sequence if it varies from the Contract Documents.
 12. Nomenclature sheets for each item of equipment.
 13. Data for terminal units, including manufacturer's name, type, size, and fittings.
 14. Notes to explain why certain final data in the body of reports vary from indicated values.
 15. Test conditions for fans and pump performance forms including the following:
 - a. Settings for outdoor-, return-, and exhaust-air dampers.
 - b. Conditions of filters.
 - c. Cooling coil, wet- and dry-bulb conditions.
 - d. Face and bypass damper settings at coils.
 - e. Fan drive settings including settings and percentage of maximum pitch diameter.
 - f. Inlet vane settings for variable-air-volume systems.
 - g. Settings for supply-air, static-pressure controller.
 - h. Other system operating conditions that affect performance.
- D. System Diagrams: Include schematic layouts of air and hydronic distribution systems. Present each system with single-line diagram and include the following:
1. Quantities of outdoor, supply, return, and exhaust airflows.
 2. Water and steam flow rates.
 3. Duct, outlet, and inlet sizes.

Weedsport Addition to Maintenance Section and Roof Replacement, MP 304.2

4. Pipe and valve sizes and locations.
 5. Terminal units.
 6. Balancing stations.
 7. Position of balancing devices.
- E. Air-Handling-Unit Test Reports: For air-handling units with coils, include the following:
1. Unit Data:
 - a. Unit identification.
 - b. Location.
 - c. Make and type.
 - d. Model number and unit size.
 - e. Manufacturer's serial number.
 - f. Unit arrangement and class.
 - g. Discharge arrangement.
 - h. Sheave make, size in inches, and bore.
 - i. Center-to-center dimensions of sheave, and amount of adjustments in inches.
 - j. Number, make, and size of belts.
 - k. Number, type, and size of filters.
 2. Motor Data:
 - a. Motor make, and frame type and size.
 - b. Horsepower and rpm.
 - c. Volts, phase, and hertz.
 - d. Full-load amperage and service factor.
 - e. Sheave make, size in inches, and bore.
 - f. Center-to-center dimensions of sheave, and amount of adjustments in inches.
 3. Test Data (Indicated and Actual Values):
 - a. Total air flow rate in cfm.
 - b. Total system static pressure in inches wg.
 - c. Fan rpm.
 - d. Discharge static pressure in inches wg.
 - e. Filter static-pressure differential in inches wg.
 - f. Preheat-coil static-pressure differential in inches wg.
 - g. Cooling-coil static-pressure differential in inches wg.
 - h. Heating-coil static-pressure differential in inches wg.
 - i. Outdoor airflow in cfm.
 - j. Return airflow in cfm.
 - k. Outdoor-air damper position.
 - l. Return-air damper position.
 - m. Vortex damper position.
- F. Apparatus-Coil Test Reports:
1. Coil Data:
 - a. System identification.
 - b. Location.
 - c. Coil type.
 - d. Number of rows.
 - e. Fin spacing in fins per inch o.c.
 - f. Make and model number.
 - g. Face area in sq. ft..
 - h. Tube size in NPS.

Weedsport Addition to Maintenance Section and Roof Replacement, MP 304.2

- i. Tube and fin materials.
- j. Circuiting arrangement.
- 2. Test Data (Indicated and Actual Values):
 - a. Air flow rate in cfm.
 - b. Average face velocity in fpm.
 - c. Air pressure drop in inches wg.
 - d. Outdoor-air, wet- and dry-bulb temperatures in deg F.
 - e. Return-air, wet- and dry-bulb temperatures in deg F.
 - f. Entering-air, wet- and dry-bulb temperatures in deg F.
 - g. Leaving-air, wet- and dry-bulb temperatures in deg F.
 - h. Water flow rate in gpm.
 - i. Water pressure differential in feet of head or psig.
 - j. Entering-water temperature in deg F.
 - k. Leaving-water temperature in deg F.
 - l. Refrigerant expansion valve and refrigerant types.
 - m. Refrigerant suction pressure in psig.
 - n. Refrigerant suction temperature in deg F.
 - o. Inlet steam pressure in psig.
- G. Gas- and Oil-Fired Heat Apparatus Test Reports: In addition to manufacturer's factory startup equipment reports, include the following:
 - 1. Unit Data:
 - a. System identification.
 - b. Location.
 - c. Make and type.
 - d. Model number and unit size.
 - e. Manufacturer's serial number.
 - f. Fuel type in input data.
 - g. Output capacity in Btu/h.
 - h. Ignition type.
 - i. Burner-control types.
 - j. Motor horsepower and rpm.
 - k. Motor volts, phase, and hertz.
 - l. Motor full-load amperage and service factor.
 - m. Sheave make, size in inches, and bore.
 - n. Center-to-center dimensions of sheave, and amount of adjustments in inches.
 - 2. Test Data (Indicated and Actual Values):
 - a. Total air flow rate in cfm.
 - b. Entering-air temperature in deg F.
 - c. Leaving-air temperature in deg F.
 - d. Air temperature differential in deg F.
 - e. Entering-air static pressure in inches wg.
 - f. Leaving-air static pressure in inches wg.
 - g. Air static-pressure differential in inches wg.
 - h. Low-fire fuel input in Btu/h.
 - i. High-fire fuel input in Btu/h.
 - j. Manifold pressure in psig.
 - k. High-temperature-limit setting in deg F.
 - l. Operating set point in Btu/h.
 - m. Motor voltage at each connection.

Weedsport Addition to Maintenance Section and Roof Replacement, MP 304.2

- n. Motor amperage for each phase.
 - o. Heating value of fuel in Btu/h.
- H. Fan Test Reports: For supply, return, and exhaust fans, include the following:
- 1. Fan Data:
 - a. System identification.
 - b. Location.
 - c. Make and type.
 - d. Model number and size.
 - e. Manufacturer's serial number.
 - f. Arrangement and class.
 - g. Sheave make, size in inches, and bore.
 - h. Center-to-center dimensions of sheave, and amount of adjustments in inches.
 - 2. Motor Data:
 - a. Motor make, and frame type and size.
 - b. Horsepower and rpm.
 - c. Volts, phase, and hertz.
 - d. Full-load amperage and service factor.
 - e. Sheave make, size in inches, and bore.
 - f. Center-to-center dimensions of sheave, and amount of adjustments in inches.
 - g. Number, make, and size of belts.
 - 3. Test Data (Indicated and Actual Values):
 - a. Total airflow rate in cfm.
 - b. Total system static pressure in inches wg.
 - c. Fan rpm.
 - d. Discharge static pressure in inches wg.
 - e. Suction static pressure in inches wg.
- I. Round, Flat-Oval, and Rectangular Duct Traverse Reports: Include a diagram with a grid representing the duct cross-section and record the following:
- 1. Report Data:
 - a. System and air-handling-unit number.
 - b. Location and zone.
 - c. Traverse air temperature in deg F.
 - d. Duct static pressure in inches wg.
 - e. Duct size in inches.
 - f. Duct area in sq. ft..
 - g. Indicated air flow rate in cfm.
 - h. Indicated velocity in fpm.
 - i. Actual air flow rate in cfm.
 - j. Actual average velocity in fpm.
 - k. Barometric pressure in psig.
- J. Instrument Calibration Reports:
- 1. Report Data:
 - a. Instrument type and make.
 - b. Serial number.
 - c. Application.
 - d. Dates of use.
 - e. Dates of calibration.

Weedsport Addition to Maintenance Section and Roof Replacement, MP 304.2

3.13 INSPECTIONS

- A. Initial Inspection:
1. After testing and balancing are complete, operate each system and randomly check measurements to verify that the system is operating according to the final test and balance readings documented in the final report.
 2. Check the following for each system:
 - a. Measure airflow of at least 10 percent of air outlets.
 - b. Measure water flow of at least 5 percent of terminals.
 - c. Measure room temperature at each thermostat/temperature sensor. Compare the reading to the set point.
 - d. Verify that balancing devices are marked with final balance position.
 - e. Note deviations from the Contract Documents in the final report.
- B. Final Inspection:
1. After initial inspection is complete and documentation by random checks verifies that testing and balancing are complete and accurately documented in the final report, request that a final inspection be made by Engineer.
 2. Engineer shall randomly select measurements, documented in the final report, to be rechecked. Rechecking shall be limited to either 10 percent of the total measurements recorded or the extent of measurements that can be accomplished in a normal 8-hour business day.
 3. If rechecks yield measurements that differ from the measurements documented in the final report by more than the tolerances allowed, the measurements shall be noted as "FAILED."
 4. If the number of "FAILED" measurements is greater than 10 percent of the total measurements checked during the final inspection, the testing and balancing shall be considered incomplete and shall be rejected.
- C. TAB Work will be considered defective if it does not pass final inspections. If TAB Work fails, proceed as follows:
1. Recheck all measurements and make adjustments. Revise the final report and balancing device settings to include all changes; resubmit the final report and request a second final inspection.
 2. If the second final inspection also fails, Owner may contract the services of another TAB contractor to complete TAB Work according to the Contract Documents and deduct the cost of the services from the original TAB contractor's final payment.
- D. Prepare test and inspection reports.

3.14 ADDITIONAL TESTS

- A. Within 90 days of completing TAB, perform additional TAB to verify that balanced conditions are being maintained throughout and to correct unusual conditions.
- B. Seasonal Periods: If initial TAB procedures were not performed during near-peak summer and winter conditions, perform additional TAB during near-peak summer and winter conditions.

END OF SECTION 230593

SECTION 230713 - DUCT INSULATION

PART 1 - GENERAL

1.1 RELATED DOCUMENTS

- A. Drawings and general provisions of the Contract, including General and Supplementary Conditions and Division 01 Specification Sections, apply to this Section.

1.2 SUMMARY

- A. Section includes insulating the following duct services:
1. Indoor, concealed supply air.
 2. Indoor, concealed exhaust between isolation damper and penetration of building exterior.
 3. Outdoor, exposed supply and return.

1.3 ACTION SUBMITTALS

- A. Product Data: For each type of product indicated. Include thermal conductivity, water-vapor permeance thickness, and jackets (both factory- and field-applied if any).
- B. Shop Drawings: Include plans, elevations, sections, details, and attachments to other work.
1. Detail application of protective shields, saddles, and inserts at hangers for each type of insulation and hanger.
 2. Detail insulation application at elbows, fittings, dampers, specialties and flanges for each type of insulation.
 3. Detail application of field-applied jackets.
 4. Detail application at linkages of control devices.

1.4 INFORMATIONAL SUBMITTALS

- A. Qualification Data: For qualified Installer.
- B. Material Test Reports: From a qualified testing agency acceptable to authorities having jurisdiction indicating, interpreting, and certifying test results for compliance of insulation materials, sealers, attachments, cements, and jackets, with requirements indicated. Include dates of tests and test methods employed.
- C. Field quality-control reports.

1.5 QUALITY ASSURANCE

- A. Surface-Burning Characteristics: For insulation and related materials, as determined by testing identical products according to ASTM E 84, by a testing agency acceptable to authorities having jurisdiction. Factory label insulation and jacket materials and adhesive, mastic, tapes, and cement material containers, with appropriate markings of applicable testing agency.
1. Insulation Installed Indoors: Flame-spread index of 25 or less, and smoke-developed index of 50 or less.
 2. Insulation Installed Outdoors: Flame-spread index of 75 or less, and smoke-developed index of 150 or less.

Weedsport Addition to Maintenance Section and Roof Replacement, MP 304.2

1.6 DELIVERY, STORAGE, AND HANDLING

- A. Packaging: Insulation material containers shall be marked by manufacturer with appropriate ASTM standard designation, type and grade, and maximum use temperature.

1.7 COORDINATION

- A. Coordinate clearance requirements with duct Installer for duct insulation application. Before preparing ductwork Shop Drawings, establish and maintain clearance requirements for installation of insulation and field-applied jackets and finishes and for space required for maintenance.
- B. Coordinate installation and testing of heat tracing.

1.8 SCHEDULING

- A. Schedule insulation application after pressure testing systems and, where required, after installing and testing heat tracing. Insulation application may begin on segments that have satisfactory test results.
- B. Complete installation and concealment of plastic materials as rapidly as possible in each area of construction.

PART 2 - PRODUCTS**2.1 INSULATION MATERIALS**

- A. Comply with requirements in "Duct Insulation Schedule, General," "Indoor Duct and Plenum Insulation Schedule," and "Aboveground, Outdoor Duct and Plenum Insulation Schedule" articles for where insulating materials shall be applied.
- B. Products shall not contain asbestos, lead, mercury, or mercury compounds.
- C. Products that come in contact with stainless steel shall have a leachable chloride content of less than 50 ppm when tested according to ASTM C 871.
- D. Insulation materials for use on austenitic stainless steel shall be qualified as acceptable according to ASTM C 795.
- E. Foam insulation materials shall not use CFC or HCFC blowing agents in the manufacturing process.
- F. Expanded Polystyrene Insulation: Closed-cell, light-weight, resilient, foamed plastic composed of hydrogen and carbon.
 - 1. Products: Subject to compliance with requirements available products that may be incorporated into the Work include, but are not limited to, the following:
 - a. Knauf Polystyrene.
- G. Mineral-Fiber Blanket Insulation: Mineral or glass fibers bonded with a thermosetting resin. Comply with ASTM C 553, Type II and ASTM C 1290, Type III with factory-applied FSK jacket. Factory-applied jacket requirements are specified in "Factory-Applied Jackets" Article.
 - 1. Products: Subject to compliance with requirements, provide one of the following:
 - a. CertainTeed Corp.; SoftTouch Duct Wrap.
 - b. Johns Manville; Microlite.
 - c. Knauf Insulation; Friendly Feel Duct Wrap.

Weedsport Addition to Maintenance Section and Roof Replacement, MP 304.2

- d. Manson Insulation Inc.; Alley Wrap.
 - e. Owens Corning; SOFTR All-Service Duct Wrap.
- H. Mineral-Fiber Board Insulation: Mineral or glass fibers bonded with a thermosetting resin. Comply with ASTM C 612, Type IA or Type IB. For duct and plenum applications, provide insulation with factory-applied FSK jacket. Factory-applied jacket requirements are specified in "Factory-Applied Jackets" Article.
- 1. Products: Subject to compliance with requirements, provide one of the following:
 - a. CertainTeed Corp.; Commercial Board.
 - b. Fibrex Insulations Inc.; FBX.
 - c. Johns Manville; 800 Series Spin-Glas.
 - d. Knauf Insulation; Insulation Board.
 - e. Manson Insulation Inc.; AK Board.
 - f. Owens Corning; Fiberglas 700 Series.

2.2 ADHESIVES

- A. Materials shall be compatible with insulation materials, jackets, and substrates and for bonding insulation to itself and to surfaces to be insulated unless otherwise indicated.
- B. Mineral-Fiber Adhesive: Comply with MIL-A-3316C, Class 2, Grade A.
- 1. Products: Subject to compliance with requirements, provide one of the following:
 - a. Childers Brand, Specialty Construction Brands, Inc., a business of H. B. Fuller Company; CP-127.Eagle Bridges - Marathon Industries; 225.
 - b. Foster Brand, Specialty Construction Brands, Inc., a business of H. B. Fuller Company; 85-60/85-70.Mon-Eco Industries, Inc.; 22-25.
 - 2. For indoor applications, adhesive shall have a VOC content of 80 g/L or less when calculated according to 40 CFR 59, Subpart D (EPA Method 24).
 - 3. Adhesive shall comply with the testing and product requirements of the California Department of Health Services' "Standard Practice for the Testing of Volatile Organic Emissions from Various Sources Using Small-Scale Environmental Chambers."
- C. ASJ Adhesive, and FSK Jacket Adhesive: Comply with MIL-A-3316C, Class 2, Grade A for bonding insulation jacket lap seams and joints.
- 1. Products: Subject to compliance with requirements, provide one of the following:
 - a. Childers Brand, Specialty Construction Brands, Inc., a business of H. B. Fuller Company; CP-82.
 - b. Eagle Bridges - Marathon Industries; 225.
 - c. Foster Brand, Specialty Construction Brands, Inc., a business of H. B. Fuller Company; 85-50.Mon-Eco Industries, Inc.; 22-25.
 - 2. For indoor applications, adhesive shall have a VOC content of 50 g/L or less when calculated according to 40 CFR 59, Subpart D (EPA Method 24).
 - 3. Adhesive shall comply with the testing and product requirements of the California Department of Health Services' "Standard Practice for the Testing of Volatile Organic Emissions from Various Sources Using Small-Scale Environmental Chambers."

2.3 MASTICS

- A. Materials shall be compatible with insulation materials, jackets, and substrates; comply with MIL-PRF-19565C, Type II.
- 1. For indoor applications, use mastics that have a VOC content of 50 g/L or less when calculated according to 40 CFR 59, Subpart D (EPA Method 24).

Weedsport Addition to Maintenance Section and Roof Replacement, MP 304.2

- B. Vapor-Barrier Mastic: Water based; suitable for indoor use on below ambient services.
1. Products: Subject to compliance with requirements, provide one of the following:
 - a. Foster Brand, Specialty Construction Brands, Inc., a business of H. B. Fuller Company; 30-80/30-90.
 - b. Vimasco Corporation; 749.
 2. Water-Vapor Permeance: ASTM E 96/E 96M, Procedure B, 0.013 perm at 43-mil dry film thickness.
 3. Service Temperature Range: Minus 20 to plus 180 deg F.
 4. Solids Content: ASTM D 1644, 58 percent by volume and 70 percent by weight.
 5. Color: White.
- C. Vapor-Barrier Mastic: Solvent based; suitable for indoor use on below ambient services.
1. Products: Subject to compliance with requirements, provide one of the following:
 - a. Childers Brand, Specialty Construction Brands, Inc., a business of H. B. Fuller Company; CP-30.
 - b. Eagle Bridges - Marathon Industries; 501.
 - c. Foster Brand, Specialty Construction Brands, Inc., a business of H. B. Fuller Company; 30-35.
 - d. Mon-Eco Industries, Inc.; 55-10.
 2. Water-Vapor Permeance: ASTM F 1249, 0.05 perm at 35-mil dry film thickness.
 3. Service Temperature Range: 0 to 180 deg F.
 4. Solids Content: ASTM D 1644, 44 percent by volume and 62 percent by weight.
 5. Color: White.
- D. Vapor-Barrier Mastic: Solvent based; suitable for outdoor use on below ambient services.
1. Products: Subject to compliance with requirements, provide one of the following:
 - a. Childers Brand, Specialty Construction Brands, Inc., a business of H. B. Fuller Company; Encacel.
 - b. Eagle Bridges - Marathon Industries; 570.
 - c. Foster Brand, Specialty Construction Brands, Inc., a business of H. B. Fuller Company; 60-95/60-96.
 2. Water-Vapor Permeance: ASTM F 1249, 0.05 perm at 30-mil dry film thickness.
 3. Service Temperature Range: Minus 50 to plus 220 deg F.
 4. Solids Content: ASTM D 1644, 33 percent by volume and 46 percent by weight.
 5. Color: White.

2.4 LAGGING ADHESIVES

- A. Description: Comply with MIL-A-3316C, Class I, Grade A and shall be compatible with insulation materials, jackets, and substrates.
1. For indoor applications, use lagging adhesives that have a VOC content of 50 g/L or less when calculated according to 40 CFR 59, Subpart D (EPA Method 24).
 2. Products: Subject to compliance with requirements, provide one of the following:
 - a. Childers Brand, Specialty Construction Brands, Inc., a business of H. B. Fuller Company; CP-50 AHV2. Foster Brand, Specialty Construction Brands, Inc., a business of H. B. Fuller Company; 30-36.
 - b. Vimasco Corporation; 713 and 714.
 3. Fire-resistant, water-based lagging adhesive and coating for use indoors to adhere fire-resistant lagging cloths over duct insulation.
 4. Service Temperature Range: 0 to plus 180 deg F.
 5. Color: White.

2.5 SEALANTS

- A. FSK and Metal Jacket Flashing Sealants:
1. Products: Subject to compliance with requirements, provide one of the following:
 - a. Childers Brand, Specialty Construction Brands, Inc., a business of H. B. Fuller Company; CP-76.Eagle Bridges - Marathon Industries; 405.
 - b. Foster Brand, Specialty Construction Brands, Inc., a business of H. B. Fuller Company; 95-44.
 - c. Mon-Eco Industries, Inc.; 44-05.
 2. Materials shall be compatible with insulation materials, jackets, and substrates.
 3. Fire- and water-resistant, flexible, elastomeric sealant.
 4. Service Temperature Range: Minus 40 to plus 250 deg F.
 5. Color: Aluminum.
 6. For indoor applications, sealants shall have a VOC content of 420 g/L or less when calculated according to 40 CFR 59, Subpart D (EPA Method 24).
 7. Sealants shall comply with the testing and product requirements of the California Department of Health Services' "Standard Practice for the Testing of Volatile Organic Emissions from Various Sources Using Small-Scale Environmental Chambers."
- B. ASJ Flashing Sealants, and Vinyl and PVC Jacket Flashing Sealants:
1. Products: Subject to compliance with requirements, available products that may be incorporated into the Work include, but are not limited to, the following:
 - a. Childers Brand, Specialty Construction Brands, Inc., a business of H. B. Fuller Company; CP-76.
 2. Materials shall be compatible with insulation materials, jackets, and substrates.
 3. Fire- and water-resistant, flexible, elastomeric sealant.
 4. Service Temperature Range: Minus 40 to plus 250 deg F.
 5. Color: White.
 6. For indoor applications, sealants shall have a VOC content of 420 g/L or less when calculated according to 40 CFR 59, Subpart D (EPA Method 24).
 7. Sealants shall comply with the testing and product requirements of the California Department of Health Services' "Standard Practice for the Testing of Volatile Organic Emissions from Various Sources Using Small-Scale Environmental Chambers."

2.6 FACTORY-APPLIED JACKETS

- A. Insulation system schedules indicate factory-applied jackets on various applications. When factory-applied jackets are indicated, comply with the following:
1. FSK Jacket: Aluminum-foil, fiberglass-reinforced scrim with kraft-paper backing; complying with ASTM C 1136, Type II.

2.7 FIELD-APPLIED CLOTHS

- A. Woven Glass-Fiber Fabric: Comply with MIL-C-20079H, Type I, plain weave, and presized a minimum of 8 oz./sq. yd..
1. Products: Subject to compliance with requirements, available products that may be incorporated into the Work include, but are not limited to, the following:
 - a. Alpha Associates, Inc.; Alpha-Maritex 84215 and 84217/9485RW, Luben 59.

2.8 FIELD-APPLIED JACKETS

- A. Field-applied jackets shall comply with ASTM C 921, Type I, unless otherwise indicated.

Weedsport Addition to Maintenance Section and Roof Replacement, MP 304.2

- B. Metal Jacket:
1. Products: Subject to compliance with requirements, provide one of the following:
 - a. Childers Brand, Specialty Construction Brands, Inc., a business of H. B. Fuller Company; Metal Jacketing Systems.
 - b. ITW Insulation Systems; Aluminum and Stainless Steel Jacketing.
 - c. RPR Products, Inc.; Insul-Mate.
 2. Aluminum Jacket: Comply with ASTM B 209, Alloy 3003, 3005, 3105, or 5005, Temper H-14.
 - a. Factory cut and rolled to size.
 - b. Finish and thickness are indicated in field-applied jacket schedules.

2.9 TAPES

- A. FSK Tape: Foil-face, vapor-retarder tape matching factory-applied jacket with acrylic adhesive; complying with ASTM C 1136.
1. Products: Subject to compliance with requirements, provide one of the following:
 - a. ABI, Ideal Tape Division; 491 AWF FSK.
 - b. Avery Dennison Corporation, Specialty Tapes Division; Fasson 0827.
 - c. Compac Corporation; 110 and 111.
 - d. Venture Tape; 1525 CW NT, 1528 CW, and 1528 CW/SQ.
 2. Width: 3 inches.
 3. Thickness: 6.5 mils.
 4. Adhesion: 90 ounces force/inch in width.
 5. Elongation: 2 percent.
 6. Tensile Strength: 40 lbf/inch in width.
 7. FSK Tape Disks and Squares: Precut disks or squares of FSK tape.
- B. Aluminum-Foil Tape: Vapor-retarder tape with acrylic adhesive.
1. Products: Subject to compliance with requirements, provide one of the following:
 - a. ABI, Ideal Tape Division; 488 AWF.
 - b. Avery Dennison Corporation, Specialty Tapes Division; Fasson 0800.
 - c. Compac Corporation; 120.
 - d. Venture Tape; 3520 CW.
 2. Width: 2 inches.
 3. Thickness: 3.7 mils.
 4. Adhesion: 100 ounces force/inch in width.
 5. Elongation: 5 percent.
 6. Tensile Strength: 34 lbf/inch in width.

2.10 SECUREMENTS

- A. Bands:
1. Products: Subject to compliance with requirements, available products that may be incorporated into the Work include, but are not limited to, the following:
 - a. ITW Insulation Systems; Gerrard Strapping and Seals.
 - b. RPR Products, Inc.; Insul-Mate Strapping, Seals, and Springs.
 2. Aluminum: ASTM B 209, Alloy 3003, 3005, 3105, or 5005; Temper H-14, 0.020 inch thick, 3/4 inch wide with wing or closed seal.
 3. Springs: Twin spring set constructed of stainless steel with ends flat and slotted to accept metal bands. Spring size determined by manufacturer for application.
- B. Insulation Pins and Hangers:

Weedsport Addition to Maintenance Section and Roof Replacement, MP 304.2

1. Capacitor-Discharge-Weld Pins: Copper- or zinc-coated steel pin, fully annealed for capacitor-discharge welding, 0.135-inch- diameter shank, length to suit depth of insulation indicated.
 - a. Products: Subject to compliance with requirements, provide one of the following:
 - 1) AGM Industries, Inc.; CWP-1.
 - 2) GEMCO; CD.
 - 3) Midwest Fasteners, Inc.; CD.
 - 4) Nelson Stud Welding; TPA, TPC, and TPS.
2. Cupped-Head, Capacitor-Discharge-Weld Pins: Copper- or zinc-coated steel pin, fully annealed for capacitor-discharge welding, 0.135-inch- diameter shank, length to suit depth of insulation indicated with integral 1-1/2-inch galvanized carbon-steel washer.
 - a. Products: Subject to compliance with requirements, provide one of the following:
 - 1) AGM Industries, Inc.; CHP-1.
 - 2) GEMCO; Cupped Head Weld Pin.
 - 3) Midwest Fasteners, Inc.; Cupped Head.
 - 4) Nelson Stud Welding; CHP.
3. Insulation-Retaining Washers: Self-locking washers formed from 0.016-inch- thick, aluminum sheet, with beveled edge sized as required to hold insulation securely in place but not less than 1-1/2 inches in diameter.
 - a. Products: Subject to compliance with requirements, provide one of the following:
 - 1) AGM Industries, Inc.; RC-150.
 - 2) GEMCO; R-150.
 - 3) Midwest Fasteners, Inc.; WA-150.
 - 4) Nelson Stud Welding; Speed Clips.
 - b. Protect ends with capped self-locking washers incorporating a spring steel insert to ensure permanent retention of cap in exposed locations.
4. Nonmetal Insulation-Retaining Washers: Self-locking washers formed from 0.016-inch-thick nylon sheet, with beveled edge sized as required to hold insulation securely in place but not less than 1-1/2 inches in diameter.
 - a. Manufacturers: Subject to compliance with requirements, available manufacturers offering products that may be incorporated into the Work include, but are not limited to, the following:
 - 1) GEMCO.
 - 2) Midwest Fasteners, Inc.

2.11 CORNER ANGLES

- A. Aluminum Corner Angles: 0.040 inch thick, minimum 1 by 1 inch, aluminum according to ASTM B 209, Alloy 3003, 3005, 3105, or 5005; Temper H-14.
- B. Stainless-Steel Corner Angles: 0.024 inch thick, minimum 1 by 1 inch, stainless steel according to ASTM A 167 or ASTM A 240/A 240M, Type 304 or Type 316.

PART 3 - EXECUTION

3.1 EXAMINATION

- A. Examine substrates and conditions for compliance with requirements for installation tolerances and other conditions affecting performance of insulation application.
 - 1. Verify that systems to be insulated have been tested and are free of defects.
 - 2. Verify that surfaces to be insulated are clean and dry.
- B. Proceed with installation only after unsatisfactory conditions have been corrected.

3.2 PREPARATION

- A. Surface Preparation: Clean and dry surfaces to receive insulation. Remove materials that will adversely affect insulation application.

3.3 GENERAL INSTALLATION REQUIREMENTS

- A. Install insulation materials, accessories, and finishes with smooth, straight, and even surfaces; free of voids throughout the length of ducts and fittings.
- B. Install insulation materials, vapor barriers or retarders, jackets, and thicknesses required for each item of duct system as specified in insulation system schedules.
- C. Install accessories compatible with insulation materials and suitable for the service. Install accessories that do not corrode, soften, or otherwise attack insulation or jacket in either wet or dry state.
- D. Install insulation with longitudinal seams at top and bottom of horizontal runs.
- E. Install multiple layers of insulation with longitudinal and end seams staggered.
- F. Keep insulation materials dry during application and finishing.
- G. Install insulation with tight longitudinal seams and end joints. Bond seams and joints with adhesive recommended by insulation material manufacturer.
- H. Install insulation with least number of joints practical.
- I. Where vapor barrier is indicated, seal joints, seams, and penetrations in insulation at hangers, supports, anchors, and other projections with vapor-barrier mastic.
 - 1. Install insulation continuously through hangers and around anchor attachments.
 - 2. For insulation application where vapor barriers are indicated, extend insulation on anchor legs from point of attachment to supported item to point of attachment to structure. Taper and seal ends at attachment to structure with vapor-barrier mastic.
 - 3. Install insert materials and install insulation to tightly join the insert. Seal insulation to insulation inserts with adhesive or sealing compound recommended by insulation material manufacturer.
- J. Apply adhesives, mastics, and sealants at manufacturer's recommended coverage rate and wet and dry film thicknesses.
- K. Install insulation with factory-applied jackets as follows:
 - 1. Draw jacket tight and smooth.
 - 2. Cover circumferential joints with 3-inch- wide strips, of same material as insulation jacket. Secure strips with adhesive and outward clinching staples along both edges of strip, spaced 4 inches o.c.

Weedsport Addition to Maintenance Section and Roof Replacement, MP 304.2

3. Overlap jacket longitudinal seams at least 1-1/2 inches. Clean and dry surface to receive self-sealing lap. Staple laps with outward clinching staples along edge at 4 inches o.c.
 - a. For below ambient services, apply vapor-barrier mastic over staples.
 4. Cover joints and seams with tape, according to insulation material manufacturer's written instructions, to maintain vapor seal.
 5. Where vapor barriers are indicated, apply vapor-barrier mastic on seams and joints and at ends adjacent to duct flanges and fittings.
- L. Cut insulation in a manner to avoid compressing insulation more than 75 percent of its nominal thickness.
- M. Finish installation with systems at operating conditions. Repair joint separations and cracking due to thermal movement.
- N. Repair damaged insulation facings by applying same facing material over damaged areas. Extend patches at least 4 inches beyond damaged areas. Adhere, staple, and seal patches similar to butt joints.

3.4 PENETRATIONS

- A. Insulation Installation at Roof Penetrations: Install insulation continuously through roof penetrations.
1. Seal penetrations with flashing sealant.
 2. For applications requiring only indoor insulation, terminate insulation above roof surface and seal with joint sealant. For applications requiring indoor and outdoor insulation, install insulation for outdoor applications tightly joined to indoor insulation ends. Seal joint with joint sealant.
 3. Extend jacket of outdoor insulation outside roof flashing at least 2 inches below top of roof flashing.
 4. Seal jacket to roof flashing with flashing sealant.
- B. Insulation Installation at Aboveground Exterior Wall Penetrations: Install insulation continuously through wall penetrations.
1. Seal penetrations with flashing sealant.
 2. For applications requiring only indoor insulation, terminate insulation inside wall surface and seal with joint sealant. For applications requiring indoor and outdoor insulation, install insulation for outdoor applications tightly joined to indoor insulation ends. Seal joint with joint sealant.
 3. Extend jacket of outdoor insulation outside wall flashing and overlap wall flashing at least 2 inches.
 4. Seal jacket to wall flashing with flashing sealant.
- C. Insulation Installation at Interior Wall and Partition Penetrations (That Are Not Fire Rated): Install insulation continuously through walls and partitions.

3.5 INSTALLATION OF INSULATION

- A. Blanket Insulation Installation on Ducts and Plenums: Secure with adhesive and insulation pins.
1. Apply adhesives according to manufacturer's recommended coverage rates per unit area, for 100 percent coverage of duct and plenum surfaces.
 2. Apply adhesive to entire circumference of ducts and to all surfaces of fittings and transitions.

Weedsport Addition to Maintenance Section and Roof Replacement, MP 304.2

3. Install either capacitor-discharge-weld pins and speed washers or cupped-head, capacitor-discharge-weld pins on sides and bottom of horizontal ducts and sides of vertical ducts as follows:
 - a. On duct sides with dimensions 18 inches and smaller, place pins along longitudinal centerline of duct. Space 3 inches maximum from insulation end joints, and 16 inches o.c.
 - b. On duct sides with dimensions larger than 18 inches, place pins 16 inches o.c. each way, and 3 inches maximum from insulation joints. Install additional pins to hold insulation tightly against surface at cross bracing.
 - c. Pins may be omitted from top surface of horizontal, rectangular ducts and plenums.
 - d. Do not overcompress insulation during installation.
 - e. Impale insulation over pins and attach speed washers.
 - f. Cut excess portion of pins extending beyond speed washers or bend parallel with insulation surface. Cover exposed pins and washers with tape matching insulation facing.
 4. For ducts and plenums with surface temperatures below ambient, install a continuous unbroken vapor barrier. Create a facing lap for longitudinal seams and end joints with insulation by removing 2 inches from one edge and one end of insulation segment. Secure laps to adjacent insulation section with 1/2-inch outward-clinching staples, 1 inch o.c. Install vapor barrier consisting of factory- or field-applied jacket, adhesive, vapor-barrier mastic, and sealant at joints, seams, and protrusions.
 - a. Repair punctures, tears, and penetrations with tape or mastic to maintain vapor-barrier seal.
 - b. Install vapor stops for ductwork and plenums operating below 50 deg F at 18-foot intervals. Vapor stops shall consist of vapor-barrier mastic applied in a Z-shaped pattern over insulation face, along butt end of insulation, and over the surface. Cover insulation face and surface to be insulated a width equal to two times the insulation thickness, but not less than 3 inches.
 5. Overlap unfaced blankets a minimum of 2 inches on longitudinal seams and end joints. At end joints, secure with steel bands spaced a maximum of 18 inches o.c.
 6. Install insulation on rectangular duct elbows and transitions with a full insulation section for each surface. Install insulation on round and flat-oval duct elbows with individually mitered gores cut to fit the elbow.
 7. Insulate duct stiffeners, hangers, and flanges that protrude beyond insulation surface with 6-inch- wide strips of same material used to insulate duct. Secure on alternating sides of stiffener, hanger, and flange with pins spaced 6 inches o.c.
- B. Board Insulation Installation on Ducts and Plenums: Secure with adhesive and insulation pins.
1. Apply adhesives according to manufacturer's recommended coverage rates per unit area, for 100 percent coverage of duct and plenum surfaces.
 2. Apply adhesive to entire circumference of ducts and to all surfaces of fittings and transitions.
 3. Install either capacitor-discharge-weld pins and speed washers or cupped-head, capacitor-discharge-weld pins on sides and bottom of horizontal ducts and sides of vertical ducts as follows:
 - a. On duct sides with dimensions 18 inches and smaller, place pins along longitudinal centerline of duct. Space 3 inches maximum from insulation end joints, and 16 inches o.c.

Weedsport Addition to Maintenance Section and Roof Replacement, MP 304.2

- b. On duct sides with dimensions larger than 18 inches, space pins 16 inches o.c. each way, and 3 inches maximum from insulation joints. Install additional pins to hold insulation tightly against surface at cross bracing.
 - c. Pins may be omitted from top surface of horizontal, rectangular ducts and plenums.
 - d. Do not overcompress insulation during installation.
 - e. Cut excess portion of pins extending beyond speed washers or bend parallel with insulation surface. Cover exposed pins and washers with tape matching insulation facing.
- 4. For ducts and plenums with surface temperatures below ambient, install a continuous unbroken vapor barrier. Create a facing lap for longitudinal seams and end joints with insulation by removing 2 inches from one edge and one end of insulation segment. Secure laps to adjacent insulation section with 1/2-inch outward-clinching staples, 1 inch o.c. Install vapor barrier consisting of factory- or field-applied jacket, adhesive, vapor-barrier mastic, and sealant at joints, seams, and protrusions.
 - a. Repair punctures, tears, and penetrations with tape or mastic to maintain vapor-barrier seal.
 - b. Install vapor stops for ductwork and plenums operating below 50 deg F at 18-foot intervals. Vapor stops shall consist of vapor-barrier mastic applied in a Z-shaped pattern over insulation face, along butt end of insulation, and over the surface. Cover insulation face and surface to be insulated a width equal to two times the insulation thickness, but not less than 3 inches.
 - 5. Install insulation on rectangular duct elbows and transitions with a full insulation section for each surface. Groove and score insulation to fit as closely as possible to outside and inside radius of elbows. Install insulation on round and flat-oval duct elbows with individually mitered gores cut to fit the elbow.
 - 6. Insulate duct stiffeners, hangers, and flanges that protrude beyond insulation surface with 6-inch- wide strips of same material used to insulate duct. Secure on alternating sides of stiffener, hanger, and flange with pins spaced 6 inches o.c.

3.6 FIELD-APPLIED JACKET INSTALLATION

- A. Where metal jackets are indicated, install with 2-inch overlap at longitudinal seams and end joints. Overlap longitudinal seams arranged to shed water. Seal end joints with weatherproof sealant recommended by insulation manufacturer. Secure jacket with stainless-steel bands 12 inches o.c. and at end joints.

3.7 FIELD QUALITY CONTROL

- A. Tests and Inspections:
 - 1. Inspect ductwork, randomly selected by Architect, by removing field-applied jacket and insulation in layers in reverse order of their installation. Extent of inspection shall be limited to one location(s) for each duct system defined in the "Duct Insulation Schedule, General" Article.
- B. All insulation applications will be considered defective Work if sample inspection reveals noncompliance with requirements.

3.8 DUCT INSULATION SCHEDULE, GENERAL

- A. Plenums and Ducts Requiring Insulation:
 - 1. Indoor, concealed supply air.

Weedsport Addition to Maintenance Section and Roof Replacement, MP 304.2

2. Indoor, concealed exhaust between isolation damper and penetration of building exterior.
 3. Indoor, exposed exhaust between isolation damper and penetration of building exterior.
 4. Outdoor, supply and return.
- B. Items Not Insulated:
1. Metal ducts with duct liner of sufficient thickness to comply with energy code and ASHRAE/IESNA 90.1.
 2. Factory-insulated flexible ducts.
 3. Factory-insulated plenums and casings.
 4. Flexible connectors.
 5. Vibration-control devices.
 6. Factory-insulated access panels and doors.

3.9 INDOOR DUCT AND PLENUM INSULATION SCHEDULE

- A. Concealed, round and flat-oval, supply-air duct insulation shall be the following:
1. Mineral-Fiber Blanket: 1-1/2 inches thick and 1.5-lb/cu. ft. nominal density.
- B. Concealed, rectangular, supply-air duct insulation shall be the following:
1. Mineral-Fiber Blanket: 2 inches thick and 1.5-lb/cu. ft. nominal density.
- C. Concealed, rectangular, exhaust-air duct insulation between isolation damper and penetration of building exterior shall be one of the following:
1. Mineral-Fiber Blanket: 2 inches thick and 1.5-lb/cu. ft. nominal density.

3.10 ABOVEGROUND, OUTDOOR DUCT AND PLENUM INSULATION SCHEDULE

- A. Insulation materials and thicknesses are identified below. If more than one material is listed for a duct system, selection from materials listed is Contractor's option.
- B. Rectangular and round, supply-air duct insulation shall be the following:
1. Expanded Polystyrene: 2 inches
 2. Number of Layers : One.
 3. Vapor Retarder Required: Yes.
- C. Rectangular and round, return-air duct insulation shall be the following:
1. Expanded Polystyrene: 2 inches
 2. Number of Layers : One.
 3. Vapor Retarder Required: Yes.

3.11 OUTDOOR, FIELD-APPLIED JACKET SCHEDULE

- A. Install jacket over insulation material. For insulation with factory-applied jacket, install the field-applied jacket over the factory-applied jacket.
- B. If more than one material is listed, selection from materials listed is Contractor's option.
- C. Ducts and Plenums:
1. Cover: 8oz. fabric with two coats of weather barrier mastic.
 2. Jacket: Aluminum, Corrugated: 0.032 inch thick.

END OF SECTION 230713

SECTION 233113 - METAL DUCTS

PART 1 - GENERAL

1.1 RELATED DOCUMENTS

- A. Drawings and general provisions of the Contract, including General and Supplementary Conditions and Division 01 Specification Sections, apply to this Section.

1.2 SUMMARY

- A. Section Includes:
1. Single-wall rectangular ducts and fittings.
 2. Single-wall round and flat-oval ducts and fittings.
 3. Sheet metal materials.
 4. Sealants and gaskets.
 5. Hangers and supports.
- B. Related Sections:
1. Section 230593 "Testing, Adjusting, and Balancing for HVAC" for testing, adjusting, and balancing requirements for metal ducts.
 2. Section 233300 "Air Duct Accessories" for dampers, sound-control devices, duct-mounting access doors and panels, turning vanes, and flexible ducts.
- C. Airstream Surfaces: Surfaces in contact with the airstream shall comply with requirements in ASHRAE 62.1.

1.3 ACTION SUBMITTALS

- A. Product Data: For each type of the following products:
1. Sealants and gaskets.
 2. Seismic-restraint devices.
- B. Shop Drawings:
1. Fabrication, assembly, and installation, including plans, elevations, sections, components, and attachments to other work.
 2. Factory- and shop-fabricated ducts and fittings.
 3. Duct layout indicating sizes, configuration, liner material, and static-pressure classes.
 4. Elevation of top of ducts.
 5. Fittings.
 6. Reinforcement and spacing.
 7. Seam and joint construction.
 8. Equipment installation based on equipment being used on Project.
 9. Locations for duct accessories, including dampers, turning vanes, and access doors and panels.
 10. Hangers and supports, including methods for duct and building attachment, seismic restraints, and vibration isolation.
- C. Delegated-Design Submittal:
1. Design Calculations: Calculations, including analysis data signed and sealed by the qualified professional engineer responsible for their preparation for seismic restraints.

Weedsport Addition to Maintenance Section and Roof Replacement, MP 304.2

1.4 INFORMATIONAL SUBMITTALS

- A. Coordination Drawings: Plans, drawn to scale, on which the following items are shown and coordinated with each other, using input from installers of the items involved:
1. Duct installation in congested spaces, indicating coordination with general construction, building components, and other building services. Indicate proposed changes to duct layout.
 2. Suspended ceiling components.
 3. Structural members to which duct will be attached.
 4. Size and location of initial access modules for acoustical tile.
 5. Penetrations of smoke barriers and fire-rated construction.
 6. Items penetrating finished ceiling including the following:
 - a. Lighting fixtures.
 - b. Air outlets and inlets.
 - c. Speakers.
 - d. Sprinklers.
 - e. Access panels.
 - f. Perimeter moldings.
- B. Welding certificates.
- C. Field quality-control reports.

1.5 QUALITY ASSURANCE

- A. Welding Qualifications: Qualify procedures and personnel according to the following:
1. AWS D1.1/D1.1M, "Structural Welding Code - Steel," for hangers and supports.
 2. AWS D1.2/D1.2M, "Structural Welding Code - Aluminum," for aluminum supports.
 3. AWS D9.1M/D9.1, "Sheet Metal Welding Code," for duct joint and seam welding.
- B. ASHRAE Compliance: Applicable requirements in ASHRAE 62.1, Section 5 - "Systems and Equipment" and Section 7 - "Construction and System Start-up."
- C. ASHRAE/IESNA Compliance: Applicable requirements in ASHRAE/IESNA 90.1, Section 6.4.4 - "HVAC System Construction and Insulation."

PART 2 - PRODUCTS**2.1 SINGLE-WALL RECTANGULAR DUCTS AND FITTINGS**

- A. General Fabrication Requirements: Comply with SMACNA's "HVAC Duct Construction Standards - Metal and Flexible" based on indicated static-pressure class unless otherwise indicated.
1. Minimum sheet metal thickness shall be 26 ga.
- B. Transverse Joints: Select joint types and fabricate according to SMACNA's "HVAC Duct Construction Standards - Metal and Flexible," Figure 2-1, "Rectangular Duct/Transverse Joints," for static-pressure class, applicable sealing requirements, materials involved, duct-support intervals, and other provisions in SMACNA's "HVAC Duct Construction Standards - Metal and Flexible."
- C. Longitudinal Seams: Select seam types and fabricate according to SMACNA's "HVAC Duct Construction Standards - Metal and Flexible," Figure 2-2, "Rectangular Duct/Longitudinal Seams," for static-pressure class, applicable sealing requirements, materials involved, duct-

Weedsport Addition to Maintenance Section and Roof Replacement, MP 304.2

support intervals, and other provisions in SMACNA's "HVAC Duct Construction Standards - Metal and Flexible."

- D. Elbows, Transitions, Offsets, Branch Connections, and Other Duct Construction: Select types and fabricate according to SMACNA's "HVAC Duct Construction Standards - Metal and Flexible," Chapter 4, "Fittings and Other Construction," for static-pressure class, applicable sealing requirements, materials involved, duct-support intervals, and other provisions in SMACNA's "HVAC Duct Construction Standards - Metal and Flexible."

2.2 SINGLE-WALL ROUND AND FLAT-OVAL DUCTS AND FITTINGS

- A. General Fabrication Requirements: Comply with SMACNA's "HVAC Duct Construction Standards - Metal and Flexible," Chapter 3, "Round, Oval, and Flexible Duct," based on indicated static-pressure class unless otherwise indicated.
1. Minimum sheet metal thickness shall be 26 ga.
 2. Manufacturers: Subject to compliance with requirements, provide products by one of the following:
 - a. Lindab Inc.
 - b. McGill AirFlow LLC.
 - c. SEMCO Incorporated.
 - d. Sheet Metal Connectors, Inc.
 - e. Spiral Manufacturing Co., Inc.
- B. Flat-Oval Ducts: Indicated dimensions are the duct width (major dimension) and diameter of the round sides connecting the flat portions of the duct (minor dimension).
- C. Transverse Joints: Select joint types and fabricate according to SMACNA's "HVAC Duct Construction Standards - Metal and Flexible," Figure 3-1, "Round Duct Transverse Joints," for static-pressure class, applicable sealing requirements, materials involved, duct-support intervals, and other provisions in SMACNA's "HVAC Duct Construction Standards - Metal and Flexible."
1. Transverse Joints in Ducts Larger Than 60 Inches in Diameter: Flanged.
- D. Longitudinal Seams: Select seam types and fabricate according to SMACNA's "HVAC Duct Construction Standards - Metal and Flexible," Figure 3-2, "Round Duct Longitudinal Seams," for static-pressure class, applicable sealing requirements, materials involved, duct-support intervals, and other provisions in SMACNA's "HVAC Duct Construction Standards - Metal and Flexible."
1. Fabricate round ducts larger than 90 inches in diameter with butt-welded longitudinal seams.
 2. Fabricate flat-oval ducts larger than 72 inches in width (major dimension) with butt-welded longitudinal seams.
- E. Tees and Laterals: Select types and fabricate according to SMACNA's "HVAC Duct Construction Standards - Metal and Flexible," Figure 3-5, "90 Degree Tees and Laterals," and Figure 3-6, "Conical Tees," for static-pressure class, applicable sealing requirements, materials involved, duct-support intervals, and other provisions in SMACNA's "HVAC Duct Construction Standards - Metal and Flexible."

2.3 SHEET METAL MATERIALS

- A. General Material Requirements: Comply with SMACNA's "HVAC Duct Construction Standards - Metal and Flexible" for acceptable materials, material thicknesses, and duct construction methods unless otherwise indicated. Sheet metal materials shall be free of pitting, seam marks, roller marks, stains, discolorations, and other imperfections.
- B. Galvanized Sheet Steel: Comply with ASTM A 653/A 653M.

Weedsport Addition to Maintenance Section and Roof Replacement, MP 304.2

1. Galvanized Coating Designation: G90.
 2. Finishes for Surfaces Exposed to View: Mill phosphatized.
- C. Reinforcement Shapes and Plates: ASTM A 36/A 36M, steel plates, shapes, and bars; black and galvanized.
1. Where black- and galvanized-steel shapes and plates are used to reinforce aluminum ducts, isolate the different metals with butyl rubber, neoprene, or EPDM gasket materials.
- D. Tie Rods: Galvanized steel, 1/4-inch minimum diameter for lengths 36 inches or less; 3/8-inch minimum diameter for lengths longer than 36 inches.

2.4 SEALANT AND GASKETS

- A. General Sealant and Gasket Requirements: Surface-burning characteristics for sealants and gaskets shall be a maximum flame-spread index of 25 and a maximum smoke-developed index of 50 when tested according to UL 723; certified by an NRTL.
- B. Water-Based Joint and Seam Sealant:
1. Application Method: Brush on.
 2. Solids Content: Minimum 65 percent.
 3. Shore A Hardness: Minimum 20.
 4. Water resistant.
 5. Mold and mildew resistant.
 6. VOC: Maximum 75 g/L (less water).
 7. Maximum Static-Pressure Class: 10-inch wg, positive and negative.
 8. Service: Indoor or outdoor.
 9. Substrate: Compatible with galvanized sheet steel (both PVC coated and bare), stainless steel, or aluminum sheets.
- C. Solvent-Based Joint and Seam Sealant:
1. Application Method: Brush on.
 2. Base: Synthetic rubber resin.
 3. Solvent: Toluene and heptane.
 4. Solids Content: Minimum 60 percent.
 5. Shore A Hardness: Minimum 60.
 6. Water resistant.
 7. Mold and mildew resistant.
 8. For indoor applications, sealant shall have a VOC content of 250 g/L or less when calculated according to 40 CFR 59, Subpart D (EPA Method 24).
 9. VOC: Maximum 395 g/L.
 10. Sealant shall comply with the testing and product requirements of the California Department of Health Services' "Standard Practice for the Testing of Volatile Organic Emissions from Various Sources Using Small-Scale Environmental Chambers."
 11. Maximum Static-Pressure Class: 10-inch wg, positive or negative.
 12. Service: Indoor or outdoor.
 13. Substrate: Compatible with galvanized sheet steel (both PVC coated and bare), stainless steel, or aluminum sheets.
- D. Flanged Joint Sealant: Comply with ASTM C 920.
1. General: Single-component, acid-curing, silicone, elastomeric.
 2. Type: S.
 3. Grade: NS.
 4. Class: 25.
 5. Use: O.

Weedsport Addition to Maintenance Section and Roof Replacement, MP 304.2

6. For indoor applications, sealant shall have a VOC content of 250 g/L or less when calculated according to 40 CFR 59, Subpart D (EPA Method 24).
 7. Sealant shall comply with the testing and product requirements of the California Department of Health Services' "Standard Practice for the Testing of Volatile Organic Emissions from Various Sources Using Small-Scale Environmental Chambers."
- E. Flange Gaskets: Butyl rubber, neoprene, or EPDM polymer with polyisobutylene plasticizer.
- F. Round Duct Joint O-Ring Seals:
1. Seal shall provide maximum leakage class of 3 cfm/100 sq. ft. at 1-inch wg and shall be rated for 10-inch wg static-pressure class, positive or negative.
 2. EPDM O-ring to seal in concave bead in coupling or fitting spigot.
 3. Double-lipped, EPDM O-ring seal, mechanically fastened to factory-fabricated couplings and fitting spigots.

2.5 HANGERS AND SUPPORTS

- A. Hanger Rods for Noncorrosive Environments: Cadmium-plated steel rods and nuts.
- B. Hanger Rods for Corrosive Environments: Electrogalvanized, all-thread rods or galvanized rods with threads painted with zinc-chromate primer after installation.
- C. Strap and Rod Sizes: Comply with SMACNA's "HVAC Duct Construction Standards - Metal and Flexible," Table 5-1, "Rectangular Duct Hangers Minimum Size," and Table 5-2, "Minimum Hanger Sizes for Round Duct."
- D. Steel Cables for Galvanized-Steel Ducts: Galvanized steel complying with ASTM A 603.
- E. Steel Cables for Stainless-Steel Ducts: Stainless steel complying with ASTM A 492.
- F. Steel Cable End Connections: Cadmium-plated steel assemblies with brackets, swivel, and bolts designed for duct hanger service; with an automatic-locking and clamping device.
- G. Duct Attachments: Sheet metal screws, blind rivets, or self-tapping metal screws; compatible with duct materials.
- H. Trapeze and Riser Supports:
1. Supports for Galvanized-Steel Ducts: Galvanized-steel shapes and plates.
 2. Supports for Stainless-Steel Ducts: Stainless-steel shapes and plates.
 3. Supports for Aluminum Ducts: Aluminum or galvanized steel coated with zinc chromate.

PART 3 - EXECUTION**3.1 DUCT INSTALLATION**

- A. Drawing plans, schematics, and diagrams indicate general location and arrangement of duct system. Indicated duct locations, configurations, and arrangements were used to size ducts and calculate friction loss for air-handling equipment sizing and for other design considerations. Install duct systems as indicated unless deviations to layout are approved on Shop Drawings and Coordination Drawings.
- B. Install ducts according to SMACNA's "HVAC Duct Construction Standards - Metal and Flexible" unless otherwise indicated.
- C. Install round and flat-oval ducts in maximum practical lengths.

Weedsport Addition to Maintenance Section and Roof Replacement, MP 304.2

- D. Install ducts with fewest possible joints.
- E. Install factory- or shop-fabricated fittings for changes in direction, size, and shape and for branch connections.
- F. Unless otherwise indicated, install ducts vertically and horizontally, and parallel and perpendicular to building lines.
- G. Install ducts close to walls, overhead construction, columns, and other structural and permanent enclosure elements of building.
- H. Install ducts with a clearance of 1 inch, plus allowance for insulation thickness.
- I. Route ducts to avoid passing through transformer vaults and electrical equipment rooms and enclosures.
- J. Where ducts pass through non-fire-rated interior partitions and exterior walls and are exposed to view, cover the opening between the partition and duct or duct insulation with sheet metal flanges of same metal thickness as the duct. Overlap openings on four sides by at least 1-1/2 inches.
- K. Where ducts pass through fire-rated interior partitions and exterior walls, install fire dampers. Comply with requirements in Section 233300 "Air Duct Accessories" for fire and smoke dampers.
- L. Protect duct interiors from moisture, construction debris and dust, and other foreign materials. Comply with SMACNA's "IAQ Guidelines for Occupied Buildings Under Construction," Appendix G, "Duct Cleanliness for New Construction Guidelines."

3.2 INSTALLATION OF EXPOSED DUCTWORK

- A. Protect ducts exposed in finished spaces from being dented, scratched, or damaged.
- B. Trim duct sealants flush with metal. Create a smooth and uniform exposed bead. Do not use two-part tape sealing system.
- C. Grind welds to provide smooth surface free of burrs, sharp edges, and weld splatter. When welding stainless steel with a No. 3 or 4 finish, grind the welds flush, polish the exposed welds, and treat the welds to remove discoloration caused by welding.
- D. Maintain consistency, symmetry, and uniformity in the arrangement and fabrication of fittings, hangers and supports, duct accessories, and air outlets.
- E. Repair or replace damaged sections and finished work that does not comply with these requirements.

3.3 DUCT SEALING

- A. Seal ducts for duct static-pressure, seal classes, and leakage classes specified in "Duct Schedule" Article according to SMACNA's "HVAC Duct Construction Standards - Metal and Flexible."

3.4 HANGER AND SUPPORT INSTALLATION

- A. Comply with SMACNA's "HVAC Duct Construction Standards - Metal and Flexible," Chapter 5, "Hangers and Supports."
- B. Building Attachments: Concrete inserts, powder-actuated fasteners, or structural-steel fasteners appropriate for construction materials to which hangers are being attached.
 1. Where practical, install concrete inserts before placing concrete.
 2. Install powder-actuated concrete fasteners after concrete is placed and completely cured.

Weedsport Addition to Maintenance Section and Roof Replacement, MP 304.2

3. Use powder-actuated concrete fasteners for standard-weight aggregate concretes or for slabs more than 4 inches thick.
 4. Do not use powder-actuated concrete fasteners for lightweight-aggregate concretes or for slabs less than 4 inches thick.
 5. Do not use powder-actuated concrete fasteners for seismic restraints.
- C. Hanger Spacing: Comply with SMACNA's "HVAC Duct Construction Standards - Metal and Flexible," Table 5-1, "Rectangular Duct Hangers Minimum Size," and Table 5-2, "Minimum Hanger Sizes for Round Duct," for maximum hanger spacing; install hangers and supports within 24 inches of each elbow and within 48 inches of each branch intersection.
- D. Hangers Exposed to View: Threaded rod and angle or channel supports.
- E. Support vertical ducts with steel angles or channel secured to the sides of the duct with welds, bolts, sheet metal screws, or blind rivets; support at each floor and at a maximum intervals of 16 feet.
- F. Install upper attachments to structures. Select and size upper attachments with pull-out, tension, and shear capacities appropriate for supported loads and building materials where used.

3.5 CONNECTIONS

- A. Make connections to equipment with flexible connectors complying with Section 233300 "Air Duct Accessories."
- B. Comply with SMACNA's "HVAC Duct Construction Standards - Metal and Flexible" for branch, outlet and inlet, and terminal unit connections.

3.6 PAINTING

- A. Paint interior of metal ducts that are visible through registers and grilles and that do not have duct liner. Apply one coat of flat, black, latex paint over a compatible galvanized-steel primer.

3.7 FIELD QUALITY CONTROL

- A. Perform tests and inspections.
- B. Leakage Tests:
1. Comply with SMACNA's "HVAC Air Duct Leakage Test Manual." Submit a test report for each test.
 2. Test the following systems:
 - a. Ducts with a Pressure Class of 2-Inch wg or Higher: Test representative duct sections, selected by Engineer from sections installed, totaling no less than 50 percent of total installed duct area for each designated pressure class.
 3. Disassemble, reassemble, and seal segments of systems to accommodate leakage testing and for compliance with test requirements.
 4. Test for leaks before applying external insulation.
 5. Conduct tests at static pressures equal to maximum design pressure of system or section being tested. If static-pressure classes are not indicated, test system at maximum system design pressure. Do not pressurize systems above maximum design operating pressure.
 6. Give seven days' advance notice for testing.
- C. Duct system will be considered defective if it does not pass tests and inspections.
- D. Prepare test and inspection reports.

Weedsport Addition to Maintenance Section and Roof Replacement, MP 304.2

3.8 START UP

- A. Air Balance: Comply with requirements in Section 230593 "Testing, Adjusting, and Balancing for HVAC."

3.9 DUCT SCHEDULE

- A. Fabricate ducts with galvanized sheet steel.
- B. Supply Ducts:
1. Ducts Connected to Constant-Volume Air-Handling Units:
 - a. Pressure Class: Positive 2-inch wg
 - b. Minimum SMACNA Seal Class: B.
 - c. SMACNA Leakage Class for Rectangular: 6.
 - d. SMACNA Leakage Class for Round and Flat Oval: 6.
 2. Ducts Connected to Variable-Air-Volume Air-Handling Units:
 - a. Pressure Class: Positive 2-inch wg .
 - b. Minimum SMACNA Seal Class: B.
 - c. SMACNA Leakage Class for Rectangular: 6.
 - d. SMACNA Leakage Class for Round and Flat Oval: 6.
- C. Return Ducts:
1. Ducts Connected to Air-Handling Units:
 - a. Pressure Class: Positive or negative 2-inch wg.
 - b. Minimum SMACNA Seal Class: B.
 - c. SMACNA Leakage Class for Rectangular: 12.
 - d. SMACNA Leakage Class for Round and Flat Oval: 12.
- D. Exhaust Ducts:
1. Ducts Connected to Fans Exhausting (ASHRAE 62.1, Class 1 and 2) Air:
 - a. Pressure Class: Negative 2-inch wg.
 - b. Minimum SMACNA Seal Class: C if negative pressure, and A if positive pressure.
 - c. SMACNA Leakage Class for Rectangular: 12.
 - d. SMACNA Leakage Class for Round and Flat Oval: 12.
- E. Intermediate Reinforcement:
1. Galvanized-Steel Ducts: Galvanized steel or carbon steel coated with zinc-chromate primer.
- F. Liner:
1. Supply Air Ducts: Flexible elastomeric, 1 inch thick.
 2. Return Air Ducts: Flexible elastomeric, 1 inch thick.
 3. Exhaust Air Ducts: Flexible elastomeric, 1 inch thick.
 4. Transfer Ducts: Flexible elastomeric, 1 inchthick.
- G. Elbow Configuration:
1. Rectangular Duct: Comply with SMACNA's "HVAC Duct Construction Standards - Metal and Flexible," Figure 4-2, "Rectangular Elbows."
 - a. Radius Type RE 1 with minimum 1.5 radius-to-diameter ratio.
 - b. Radius Type RE 3 with minimum 1.0 radius-to-diameter ratio and two vanes.
 - c. Mitered Type RE 2 with vanes complying with SMACNA's "HVAC Duct Construction Standards - Metal and Flexible," Figure 4-3, "Vanes and Vane Runners," and Figure 4-4, "Vane Support in Elbows."

Weedsport Addition to Maintenance Section and Roof Replacement, MP 304.2

2. Round Duct: Comply with SMACNA's "HVAC Duct Construction Standards - Metal and Flexible," Figure 3-4, "Round Duct Elbows."
 - a. Minimum Radius-to-Diameter Ratio and Elbow Segments: Comply with SMACNA's "HVAC Duct Construction Standards - Metal and Flexible," Table 3-1, "Mitered Elbows." Elbows with less than 90-degree change of direction have proportionately fewer segments.
 - 1) Velocity 1000 fpm or Lower: 0.5 radius-to-diameter ratio and three segments for 90-degree elbow.
 - 2) Velocity 1000 to 1500 fpm: 1.0 radius-to-diameter ratio and four segments for 90-degree elbow.
 - 3) Velocity 1500 fpm or Higher: 1.5 radius-to-diameter ratio and five segments for 90-degree elbow.
 - 4) Radius-to Diameter Ratio: 1.5.
 - b. Round Elbows, 12 Inches and Smaller in Diameter: Stamped or pleated.
 - c. Round Elbows, 14 Inches and Larger in Diameter: Standing seam.
- H. Branch Configuration:
 1. Rectangular Duct: Comply with SMACNA's "HVAC Duct Construction Standards - Metal and Flexible," Figure 4-6, "Branch Connection."
 - a. Rectangular Main to Rectangular Branch: 45-degree entry.
 - b. Rectangular Main to Round Branch: Spin in.
 2. Round and Flat Oval: Comply with SMACNA's "HVAC Duct Construction Standards - Metal and Flexible," Figure 3-5, "90 Degree Tees and Laterals," and Figure 3-6, "Conical Tees." Saddle taps are permitted in existing duct.
 - a. Velocity 1000 fpm or Lower: 90-degree tap.
 - b. Velocity 1000 to 1500 fpm: Conical tap.
 - c. Velocity 1500 fpm or Higher: 45-degree lateral.

END OF SECTION 233113

SECTION 233300 - AIR DUCT ACCESSORIES

PART 1 - GENERAL

1.1 RELATED DOCUMENTS

- A. Drawings and general provisions of the Contract, including General and Supplementary Conditions and Division 01 Specification Sections, apply to this Section.

1.2 SUMMARY

- A. Section Includes:
 - 1. Backdraft dampers.
 - 2. Manual volume dampers.
 - 3. Control dampers.
 - 4. Turning vanes.
 - 5. Duct-mounted access doors.
 - 6. Flexible connectors.
 - 7. Flexible ducts.
 - 8. Duct accessory hardware.

1.3 ACTION SUBMITTALS

- A. Product Data: For each type of product.
 - 1. For duct silencers, include pressure drop and dynamic insertion loss data. Include breakout noise calculations for high transmission loss casings.

1.4 INFORMATIONAL SUBMITTALS

- A. Coordination Drawings: Reflected ceiling plans, drawn to scale, on which ceiling-mounted access panels and access doors required for access to duct accessories are shown and coordinated with each other, using input from Installers of the items involved.
- B. Source quality-control reports.

1.5 CLOSEOUT SUBMITTALS

- A. Operation and Maintenance Data: For air duct accessories to include in operation and maintenance manuals.

PART 2 - PRODUCTS

2.1 ASSEMBLY DESCRIPTION

- A. Comply with NFPA 90A, "Installation of Air Conditioning and Ventilating Systems," and with NFPA 90B, "Installation of Warm Air Heating and Air Conditioning Systems."
- B. Comply with SMACNA's "HVAC Duct Construction Standards - Metal and Flexible" for acceptable materials, material thicknesses, and duct construction methods unless otherwise indicated. Sheet metal materials shall be free of pitting, seam marks, roller marks, stains, discolorations, and other imperfections.

2.2 MATERIALS

- A. Galvanized Sheet Steel: Comply with ASTM A 653/A 653M.

Weedsport Addition to Maintenance Section and Roof Replacement, MP 304.2

1. Galvanized Coating Designation: G60.
 2. Exposed-Surface Finish: Mill phosphatized.
- B. Reinforcement Shapes and Plates: Galvanized-steel reinforcement where installed on galvanized sheet metal ducts; compatible materials for aluminum and stainless-steel ducts.
- C. Tie Rods: Galvanized steel, 1/4-inch minimum diameter for lengths 36 inches or less; 3/8-inch minimum diameter for lengths longer than 36 inches.

2.3 BACKDRAFT AND PRESSURE RELIEF DAMPERS

- A. Manufacturers: Subject to compliance with requirements, provide products by one of the following:
1. Air Balance Inc.; a division of Mestek, Inc.
 2. American Warming and Ventilating; a division of Mestek, Inc.
 3. Cesco Products; a division of Mestek, Inc.
 4. Greenheck Fan Corporation.
 5. Lloyd Industries, Inc.
 6. Nailor Industries Inc.
 7. NCA Manufacturing, Inc.
 8. Pottorff.
 9. Ruskin Company.
 10. Vent Products Company, Inc.
- B. Description: Gravity balanced.
- C. Maximum Air Velocity: 2000 fpm
- D. Frame: Hat-shaped, 0.05-inch- thick, galvanized sheet steel, with welded corners or mechanically attached and mounting flange.
- E. Blades: Multiple single-piece blades, maximum 6-inch width, 0.025-inch- thick, roll-formed aluminum with sealed edges.
- F. Blade Action: Parallel.
- G. Blade Seals: Extruded vinyl, mechanically locked.
- H. Blade Axles:
1. Material: Nonferrous metal.
 2. Diameter: 0.20 inch.
- I. Return Spring: Adjustable tension.

2.4 MANUAL VOLUME DAMPERS

- A. Standard, Steel, Manual Volume Dampers:
1. Manufacturers: Subject to compliance with requirements, provide products by one of the following:
 - a. Air Balance Inc.; a division of Mestek, Inc.
 - b. American Warming and Ventilating; a division of Mestek, Inc.
 - c. Flexmaster U.S.A., Inc.
 - d. McGill AirFlow LLC.
 - e. Nailor Industries Inc.
 - f. Pottorff.
 - g. Ruskin Company.
 - h. Trox USA Inc.

Weedsport Addition to Maintenance Section and Roof Replacement, MP 304.2

- i. Vent Products Company, Inc.
 2. Standard leakage rating.
 3. Suitable for horizontal or vertical applications.
 4. Frames:
 - a. Frame: Hat-shaped, 0.094-inch- thick, galvanized sheet steel.
 - b. Mitered and welded corners.
 - c. Flanges for attaching to walls and flangeless frames for installing in ducts.
 5. Blades:
 - a. Multiple or single blade.
 - b. Parallel- or opposed-blade design.
 - c. Stiffen damper blades for stability.
 - d. Galvanized-steel, 0.064 inch thick.
 6. Blade Axles: Galvanized steel.
 7. Bearings:
 - a. Stainless-steel sleeve.
 - b. Dampers in ducts with pressure classes of 3-inch wg or less shall have axles full length of damper blades and bearings at both ends of operating shaft.
 8. Tie Bars and Brackets: Galvanized steel.
- B. Low-Leakage, Steel, Manual Volume Dampers:
1. Manufacturers: Subject to compliance with requirements, provide products by one of the following:
 - a. Air Balance Inc.; a division of Mestek, Inc.
 - b. American Warming and Ventilating; a division of Mestek, Inc.
 - c. McGill AirFlow LLC.
 - d. Nailor Industries Inc.
 - e. Pottorff.
 - f. Ruskin Company.
 - g. Trox USA Inc.
 - h. Vent Products Company, Inc.
 2. Comply with AMCA 500-D testing for damper rating.
 3. Low-leakage rating and bearing AMCA's Certified Ratings Seal for both air performance and air leakage.
 4. Suitable for horizontal or vertical applications.
 5. Frames:
 - a. Hat shaped.
 - b. 0.094-inch- thick, galvanized sheet steel.
 - c. Mitered and welded corners.
 - d. Flanges for attaching to walls and flangeless frames for installing in ducts.
 6. Blades:
 - a. Multiple or single blade.
 - b. Parallel- or opposed-blade design.
 - c. Stiffen damper blades for stability.
 - d. Galvanized, roll-formed steel, 0.064 inch thick.
 7. Blade Axles: Galvanized steel.
 8. Bearings:
 - a. Oil-impregnated stainless-steel sleeve.
 - b. Dampers in ducts with pressure classes of 3-inch wg or less shall have axles full length of damper blades and bearings at both ends of operating shaft.
 9. Blade Seals: Neoprene.
 10. Jamb Seals: Cambered stainless steel.

Weedsport Addition to Maintenance Section and Roof Replacement, MP 304.2

11. Tie Bars and Brackets: Galvanized steel.
 12. Accessories:
 - a. Include locking device to hold single-blade dampers in a fixed position without vibration.
- C. Jackshaft:
1. Size: 0.5-inch diameter.
 2. Material: Galvanized-steel pipe rotating within pipe-bearing assembly mounted on supports at each mullion and at each end of multiple-damper assemblies.
 3. Length and Number of Mountings: As required to connect linkage of each damper in multiple-damper assembly.
- D. Damper Hardware:
1. Zinc-plated, die-cast core with dial and handle made of 3/32-inch- thick zinc-plated steel, and a 3/4-inch hexagon locking nut.
 2. Include center hole to suit damper operating-rod size.
 3. Include elevated platform for insulated duct mounting.

2.5 TURNING VANES

- A. Manufacturers: Subject to compliance with requirements, provide products by one of the following:
1. Ductmate Industries, Inc.
 2. Duro Dyne Inc.
 3. Elgen Manufacturing.
 4. METALAIRE, Inc.
 5. SEMCO Incorporated.
 6. Ward Industries, Inc.; a division of Hart & Cooley, Inc.
- B. Manufactured Turning Vanes for Metal Ducts: Curved blades of galvanized sheet steel; support with bars perpendicular to blades set; set into vane runners suitable for duct mounting.
1. Acoustic Turning Vanes: Fabricate airfoil-shaped aluminum extrusions with perforated faces and fibrous-glass fill.
- C. Manufactured Turning Vanes for Nonmetal Ducts: Fabricate curved blades of resin-bonded fiberglass with acrylic polymer coating; support with bars perpendicular to blades set; set into vane runners suitable for duct mounting.
- D. General Requirements: Comply with SMACNA's "HVAC Duct Construction Standards - Metal and Flexible"; Figures 4-3, "Vanes and Vane Runners," and 4-4, "Vane Support in Elbows."
- E. Vane Construction: Double wall.
- F. Vane Construction: Single wall for ducts up to 48 inches wide and double wall for larger dimensions.

2.6 DUCT-MOUNTED ACCESS DOORS

- A. Manufacturers: Subject to compliance with requirements, provide products by one of the following:
1. American Warming and Ventilating; a division of Mestek, Inc.
 2. Cesco Products; a division of Mestek, Inc.
 3. Ductmate Industries, Inc.
 4. Elgen Manufacturing.
 5. Flexmaster U.S.A., Inc.

Weedsport Addition to Maintenance Section and Roof Replacement, MP 304.2

6. Greenheck Fan Corporation.
 7. McGill AirFlow LLC.
 8. Nailor Industries Inc.
 9. Pottorff.
 10. Ventfabrics, Inc.
 11. Ward Industries, Inc.; a division of Hart & Cooley, Inc.
- B. Duct-Mounted Access Doors: Fabricate access panels according to SMACNA's "HVAC Duct Construction Standards - Metal and Flexible"; Figures 7-2, "Duct Access Doors and Panels," and 7-3, "Access Doors - Round Duct."
1. Door:
 - a. Double wall, rectangular.
 - b. Galvanized sheet metal with insulation fill and thickness as indicated for duct pressure class.
 - c. Vision panel.
 - d. Hinges and Latches: 1-by-1-inchbutt or piano hinge and cam latches.
 - e. Fabricate doors airtight and suitable for duct pressure class.
 2. Frame: Galvanized sheet steel, with bend-over tabs and foam gaskets.
 3. Number of Hinges and Locks:
 - a. Access Doors Less Than 12 Inches Square: No hinges and two sash locks.
 - b. Access Doors up to 18 Inches Square: Continuous and two sash locks.
 - c. Access Doors up to 24 by 48 Inches: Three hinges and two compression latches.
 - d. Access Doors Larger Than 24 by 48 Inches: Four hinges and two compression latches with outside and inside handles.

2.7 FLEXIBLE CONNECTORS

- A. Manufacturers: Subject to compliance with requirements, provide products by one of the following:
1. Ductmate Industries, Inc.
 2. Duro Dyne Inc.
 3. Elgen Manufacturing.
 4. Ventfabrics, Inc.
 5. Ward Industries, Inc.; a division of Hart & Cooley, Inc.
- B. Materials: Flame-retardant or noncombustible fabrics.
- C. Coatings and Adhesives: Comply with UL 181, Class 1.
- D. Metal-Edged Connectors: Factory fabricated with a fabric strip 3-1/2 inches wide attached to two strips of 2-3/4-inch- wide, 0.028-inch- thick, galvanized sheet steel or 0.032-inch- thick aluminum sheets. Provide metal compatible with connected ducts.
- E. Indoor System, Flexible Connector Fabric: Glass fabric double coated with neoprene.
1. Minimum Weight: 26 oz./sq. yd..
 2. Tensile Strength: 480 lbf/inch in the warp and 360 lbf/inch in the filling.
 3. Service Temperature: Minus 40 to plus 200 deg F.
- F. Outdoor System, Flexible Connector Fabric: Glass fabric double coated with weatherproof, synthetic rubber resistant to UV rays and ozone.
1. Minimum Weight: 24 oz./sq. yd..
 2. Tensile Strength: 530 lbf/inch in the warp and 440 lbf/inch in the filling.
 3. Service Temperature: Minus 50 to plus 250 deg F.
- G. High-Temperature System, Flexible Connectors: Glass fabric coated with silicone rubber.

Weedsport Addition to Maintenance Section and Roof Replacement, MP 304.2

1. Minimum Weight: 16 oz./sq. yd..
 2. Tensile Strength: 285 lbf/inch in the warp and 185 lbf/inch in the filling.
 3. Service Temperature: Minus 67 to plus 500 deg F.
- H. High-Corrosive-Environment System, Flexible Connectors: Glass fabric with chemical-resistant coating.
1. Minimum Weight: 14 oz./sq. yd..
 2. Tensile Strength: 450 lbf/inch in the warp and 340 lbf/inch in the filling.
 3. Service Temperature: Minus 67 to plus 500 deg F.
- I. Thrust Limits: Combination coil spring and elastomeric insert with spring and insert in compression, and with a load stop. Include rod and angle-iron brackets for attaching to fan discharge and duct.
1. Frame: Steel, fabricated for connection to threaded rods and to allow for a maximum of 30 degrees of angular rod misalignment without binding or reducing isolation efficiency.
 2. Outdoor Spring Diameter: Not less than 80 percent of the compressed height of the spring at rated load.
 3. Minimum Additional Travel: 50 percent of the required deflection at rated load.
 4. Lateral Stiffness: More than 80 percent of rated vertical stiffness.
 5. Overload Capacity: Support 200 percent of rated load, fully compressed, without deformation or failure.
 6. Elastomeric Element: Molded, oil-resistant rubber or neoprene.
 7. Coil Spring: Factory set and field adjustable for a maximum of 1/4-inch movement at start and stop.

2.8 FLEXIBLE DUCTS

- A. Manufacturers: Subject to compliance with requirements, provide products by one of the following:
1. Flexmaster U.S.A., Inc.
 2. McGill AirFlow LLC.
 3. Ward Industries, Inc.; a division of Hart & Cooley, Inc.
- B. Insulated, Flexible Duct: UL 181, Class 1, black polymer film supported by helically wound, spring-steel wire; fibrous-glass insulation; polyethylene vapor-barrier film.
1. Pressure Rating: 4-inch wg positive and 0.5-inch wg negative.
 2. Maximum Air Velocity: 4000 fpm.
 3. Temperature Range: Minus 20 to plus 175 deg F.
 4. Insulation R-Value: Comply with ASHRAE/IESNA 90.1.
- C. Flexible Duct Connectors:
1. Clamps: Stainless-steel band with cadmium-plated hex screw to tighten band with a worm-gear action or Nylon strap in sizes 3 through 18 inches, to suit duct size.
 2. Non-Clamp Connectors: Adhesive.

2.9 DUCT ACCESSORY HARDWARE

- A. Instrument Test Holes: Cast iron or cast aluminum to suit duct material, including screw cap and gasket. Size to allow insertion of pitot tube and other testing instruments and of length to suit duct-insulation thickness.
- B. Adhesives: High strength, quick setting, neoprene based, waterproof, and resistant to gasoline and grease.

Weedsport Addition to Maintenance Section and Roof Replacement, MP 304.2

PART 3 - EXECUTION

3.1 INSTALLATION

- A. Install duct accessories according to applicable details in SMACNA's "HVAC Duct Construction Standards - Metal and Flexible" for metal ducts and in NAIMA AH116, "Fibrous Glass Duct Construction Standards," for fibrous-glass ducts.
- B. Install duct accessories of materials suited to duct materials; use galvanized-steel accessories in galvanized-steel and fibrous-glass ducts, stainless-steel accessories in stainless-steel ducts, and aluminum accessories in aluminum ducts.
- C. Install backdraft dampers at inlet of exhaust fans or exhaust ducts as close as possible to exhaust fan unless otherwise indicated.
- D. Install volume dampers at points on supply, return, and exhaust systems where branches extend from larger ducts. Where dampers are installed in ducts having duct liner, install dampers with hat channels of same depth as liner, and terminate liner with nosing at hat channel.
 - 1. Install steel volume dampers in steel ducts.
 - 2. Install aluminum volume dampers in aluminum ducts.
- E. Set dampers to fully open position before testing, adjusting, and balancing.
- F. Install test holes at fan inlets and outlets and elsewhere as indicated.
- G. Connect ducts to duct silencers with flexible duct connectors.
- H. Install duct access doors on sides of ducts to allow for inspecting, adjusting, and maintaining accessories and equipment at the following locations:
 - 1. On both sides of duct coils.
 - 2. Upstream from duct filters.
 - 3. At outdoor-air intakes and mixed-air plenums.
 - 4. At drain pans and seals.
 - 5. Downstream from, control dampers, backdraft dampers, and equipment.
 - 6. Adjacent to and close enough to fire or smoke dampers, to reset or reinstall fusible links. Access doors for access to fire or smoke dampers having fusible links shall be pressure relief access doors and shall be outward operation for access doors installed upstream from dampers and inward operation for access doors installed downstream from dampers.
 - 7. At each change in direction and at maximum 50-foot spacing.
 - 8. Upstream or downstream from duct silencers.
 - 9. Control devices requiring inspection.
 - 10. Elsewhere as indicated.
- I. Install access doors with swing against duct static pressure.
- J. Access Door Sizes:
 - 1. One-Hand or Inspection Access: 8 by 5 inches.
 - 2. Two-Hand Access: 12 by 6 inches.
 - 3. Head and Hand Access: 18 by 10 inches.
 - 4. Head and Shoulders Access: 21 by 14 inches.
 - 5. Body Access: 25 by 14 inches.
 - 6. Body plus Ladder Access: 25 by 17 inches.
- K. Label access doors according to Section 230553 "Identification for HVAC Piping and Equipment" to indicate the purpose of access door.
- L. Install flexible connectors to connect ducts to equipment.

Weedsport Addition to Maintenance Section and Roof Replacement, MP 304.2

- M. For fans developing static pressures of 5-inch wg and more, cover flexible connectors with loaded vinyl sheet held in place with metal straps.
- N. Connect terminal units to supply ducts directly or with maximum 12-inch lengths of flexible duct. Do not use flexible ducts to change directions.
- O. Connect diffusers or light troffer boots to ducts directly or with maximum 60-inch lengths of flexible duct clamped or strapped in place.
- P. Connect flexible ducts to metal ducts with adhesive and draw bands.
- Q. Install duct test holes where required for testing and balancing purposes.
- R. Install thrust limits at centerline of thrust, symmetrical on both sides of equipment. Attach thrust limits at centerline of thrust and adjust to a maximum of 1/4-inch movement during start and stop of fans.

3.2 FIELD QUALITY CONTROL

- A. Tests and Inspections:
 - 1. Operate dampers to verify full range of movement.
 - 2. Inspect locations of access doors and verify that purpose of access door can be performed.
 - 3. Operate fire, smoke, and combination fire and smoke dampers to verify full range of movement and verify that proper heat-response device is installed.
 - 4. Inspect turning vanes for proper and secure installation.
 - 5. Operate remote damper operators to verify full range of movement of operator and damper.

END OF SECTION 233300

SECTION 233423 - HVAC POWER VENTILATORS

PART 1 - GENERAL

1.1 RELATED DOCUMENTS

- A. Drawings and general provisions of the Contract, including General and Supplementary Conditions and Division 01 Specification Sections, apply to this Section.

1.2 SUMMARY

- A. Section Includes:
 - 1. Centrifugal roof ventilators.

1.3 PERFORMANCE REQUIREMENTS

- A. Project Altitude: Base fan-performance ratings on actual Project site elevations.
- B. Operating Limits: Classify according to AMCA 99.

1.4 ACTION SUBMITTALS

- A. Product Data: For each type of product indicated. Include rated capacities, operating characteristics, and furnished specialties and accessories. Also include the following:
 - 1. Certified fan performance curves with system operating conditions indicated.
 - 2. Certified fan sound-power ratings.
 - 3. Motor ratings and electrical characteristics, plus motor and electrical accessories.
 - 4. Material thickness and finishes, including color charts.
 - 5. Dampers, including housings, linkages, and operators.
 - 6. Roof curbs.
 - 7. Fan speed controllers.
- B. Shop Drawings: Include plans, elevations, sections, details, and attachments to other work.
 - 1. Detail equipment assemblies and indicate dimensions, weights, loads, required clearances, method of field assembly, components, and location and size of each field connection.
 - 2. Wiring Diagrams: For power, signal, and control wiring.

1.5 INFORMATIONAL SUBMITTALS

- A. Coordination Drawings: Reflected ceiling plans and other details, drawn to scale, on which the following items are shown and coordinated with each other, using input from Installers of the items involved:
 - 1. Roof framing and support members relative to duct penetrations.
 - 2. Ceiling suspension assembly members.
 - 3. Size and location of initial access modules for acoustical tile.
 - 4. Ceiling-mounted items including light fixtures, diffusers, grilles, speakers, sprinklers, access panels, and special moldings.
- B. Field quality-control reports.

1.6 CLOSEOUT SUBMITTALS

- A. Operation and Maintenance Data: For power ventilators to include in emergency, operation, and maintenance manuals.

1.7 MAINTENANCE MATERIAL SUBMITTALS

- A. Furnish extra materials that match products installed and that are packaged with protective covering for storage and identified with labels describing contents.
 - 1. Belts: One set for each belt-driven unit.

1.8 QUALITY ASSURANCE

- A. Electrical Components, Devices, and Accessories: Listed and labeled as defined in NFPA 70, by a qualified testing agency, and marked for intended location and application.
- B. AMCA Compliance: Fans shall have AMCA-Certified performance ratings and shall bear the AMCA-Certified Ratings Seal.
- C. UL Standards: Power ventilators shall comply with UL 705.

1.9 COORDINATION

- A. Coordinate size and location of structural-steel support members.
- B. Coordinate sizes and locations of roof curbs, equipment supports, and roof penetrations with actual equipment provided.

PART 2 - PRODUCTS**2.1 CENTRIFUGAL ROOF VENTILATORS**

- A. Manufacturers: Subject to compliance with requirements, provide products by one of the following:
 - 1. Breidert Air Products.
 - 2. Carnes Company.
 - 3. Greenheck Fan Corporation.
 - 4. Hartzell Fan Incorporated.
 - 5. Loren Cook Company.
 - 6. Twin City Fans.
- B. Housing: Removable, spun-aluminum, dome top and outlet baffle; square, one-piece, aluminum base with venturi inlet cone.
 - 1. Hinged Subbase: Galvanized-steel hinged arrangement permitting service and maintenance.
- C. Fan Wheels: Aluminum hub and wheel with backward-inclined blades.
- D. Belt Drives:
 - 1. Resiliently mounted to housing.
 - 2. Fan Shaft: Turned, ground, and polished steel; keyed to wheel hub.
 - 3. Shaft Bearings: Permanently lubricated, permanently sealed, self-aligning ball bearings.
 - 4. Pulleys: Cast-iron, adjustable-pitch motor pulley.
 - 5. Fan and motor isolated from exhaust airstream.

Weedsport Addition to Maintenance Section and Roof Replacement, MP 304.2

- E. Accessories:
1. Disconnect Switch: Nonfusible type, with thermal-overload protection mounted inside fan housing, factory wired through an internal aluminum conduit.
 2. Bird Screens: Removable, 1/2-inch mesh, aluminum or brass wire.
 3. Dampers: Counterbalanced, parallel-blade, backdraft dampers mounted in curb base; factory set to close when fan stops.
 4. Motorized Dampers: Parallel-blade dampers mounted in curb base with electric actuator; wired to close when fan stops.
- F. Roof Curbs: Galvanized steel; mitered and welded corners; 1-1/2-inch- thick, rigid, fiberglass insulation adhered to inside walls; and 1-1/2-inch wood nailer. Size as required to suit roof opening and fan base.
1. Configuration: Built-in cant and mounting flange.
 2. Overall Height: 16 inches
 3. Sound Curb: Curb with sound-absorbing insulation.
 4. Pitch Mounting: Manufacture curb for roof slope.
 5. Metal Liner: Galvanized steel.
 6. Mounting Pedestal: Galvanized steel with removable access panel.
 7. Vented Curb: Unlined with louvered vents in vertical sides.

2.2 MOTORS

- A. Comply with NEMA designation, temperature rating, service factor, enclosure type, and efficiency requirements for motors specified in Section 230513 "Common Motor Requirements for HVAC Equipment."
1. Motor Sizes: Minimum size as indicated. If not indicated, large enough so driven load will not require motor to operate in service factor range above 1.0.
- B. Enclosure Type: Totally enclosed, fan cooled.

2.3 SOURCE QUALITY CONTROL

- A. Certify sound-power level ratings according to AMCA 301, "Methods for Calculating Fan Sound Ratings from Laboratory Test Data." Factory test fans according to AMCA 300, "Reverberant Room Method for Sound Testing of Fans." Label fans with the AMCA-Certified Ratings Seal.
- B. Certify fan performance ratings, including flow rate, pressure, power, air density, speed of rotation, and efficiency by factory tests according to AMCA 210, "Laboratory Methods of Testing Fans for Aerodynamic Performance Rating." Label fans with the AMCA-Certified Ratings Seal.

PART 3 - EXECUTION**3.1 INSTALLATION**

- A. Install power ventilators level and plumb.
- B. Secure roof-mounted fans to roof curbs with cadmium-plated hardware.
- C. Install units with clearances for service and maintenance.
- D. Label units according to requirements specified in Section 230553 "Identification for HVAC Piping and Equipment."

3.2 CONNECTIONS

- A. Drawings indicate general arrangement of ducts and duct accessories. Make final duct connections with flexible connectors. Flexible connectors are specified in Section 233300 "Air Duct Accessories."
- B. Install ducts adjacent to power ventilators to allow service and maintenance.

3.3 FIELD QUALITY CONTROL

- A. Perform tests and inspections.
 - 1. Manufacturer's Field Service: Engage a factory-authorized service representative to inspect components, assemblies, and equipment installations, including connections, and to assist in testing.
- B. Tests and Inspections:
 - 1. Verify that shipping, blocking, and bracing are removed.
 - 2. Verify that unit is secure on mountings and supporting devices, and that connections to ducts and electrical components are complete. Verify that proper thermal-overload protection is installed in motors, starters, and disconnect switches.
 - 3. Verify that cleaning and adjusting are complete.
 - 4. Disconnect fan drive from motor, verify proper motor rotation direction, and verify fan wheel free rotation and smooth bearing operation. Reconnect fan drive system, align and adjust belts, and install belt guards.
 - 5. Adjust belt tension.
 - 6. Adjust damper linkages for proper damper operation.
 - 7. Verify lubrication for bearings and other moving parts.
 - 8. Verify that manual and automatic volume control and fire and smoke dampers in connected ductwork systems are in fully open position.
 - 9. Disable automatic temperature-control operators, energize motor and adjust fan to indicated rpm, and measure and record motor voltage and amperage.
 - 10. Shut unit down and reconnect automatic temperature-control operators.
 - 11. Remove and replace malfunctioning units and retest as specified above.
- C. Test and adjust controls and safeties. Replace damaged and malfunctioning controls and equipment.
- D. Prepare test and inspection reports.

3.4 ADJUSTING

- A. Adjust damper linkages for proper damper operation.
- B. Adjust belt tension.
- C. Comply with requirements in Section 230593 "Testing, Adjusting, and Balancing for HVAC" for testing, adjusting, and balancing procedures.
- D. Replace fan and motor pulleys as required to achieve design airflow.
- E. Lubricate bearings.

END OF SECTION 233423

SECTION 233713 - DIFFUSERS, REGISTERS, AND GRILLES

PART 1 - GENERAL

1.1 RELATED DOCUMENTS

- A. Drawings and general provisions of the Contract, including General and Supplementary Conditions and Division 01 Specification Sections, apply to this Section.

1.2 SUMMARY

- A. Section Includes:
1. Rectangular and square ceiling diffusers.
 2. Fixed face grilles.

1.3 ACTION SUBMITTALS

- A. Product Data: For each type of product indicated, include the following:
1. Data Sheet: Indicate materials of construction, finish, and mounting details; and performance data including throw and drop, static-pressure drop, and noise ratings.
 2. Diffuser, Register, and Grille Schedule: Indicate drawing designation, room location, quantity, model number, size, and accessories furnished.
- B. Samples for Initial Selection: For diffusers, registers, and grilles with factory-applied color finishes.
- C. Samples for Verification: For diffusers, registers, and grilles, in manufacturer's standard sizes to verify color selected.

1.4 INFORMATIONAL SUBMITTALS

- A. Coordination Drawings: Reflected ceiling plans, drawn to scale, on which the following items are shown and coordinated with each other, using input from Installers of the items involved:
1. Ceiling suspension assembly members.
 2. Method of attaching hangers to building structure.
 3. Size and location of initial access modules for acoustical tile.
 4. Ceiling-mounted items including lighting fixtures, diffusers, grilles, speakers, sprinklers, access panels, and special moldings.
 5. Duct access panels.
- B. Source quality-control reports.

PART 2 - PRODUCTS

2.1 CEILING DIFFUSERS

- A. Rectangular and Square Ceiling Diffusers:
1. Basis-of-Design Product: Subject to compliance with requirements, provide product indicated on Drawings or comparable product by one of the following:
 - a. Anemostat Products; a Mestek company.
 - b. Krueger.
 - c. METALAIRE, Inc.
 - d. Nailor Industries Inc.
 - e. Price Industries.

Weedsport Addition to Maintenance Section and Roof Replacement, MP 304.2

- f. Titus.

2.2 REGISTERS AND GRILLES**A. Fixed Face Grille:**

- 1. Basis-of-Design Product: Subject to compliance with requirements, provide product indicated on Drawings or comparable product by one of the following:
 - a. Anemostat Products; a Mestek company.
 - b. Krueger.
 - c. Nailor Industries Inc.
 - d. Price Industries.
 - e. Titus.

2.3 SOURCE QUALITY CONTROL

- A. Verification of Performance: Rate diffusers, registers, and grilles according to ASHRAE 70, "Method of Testing for Rating the Performance of Air Outlets and Inlets."

PART 3 - EXECUTION**3.1 EXAMINATION**

- A. Examine areas where diffusers, registers, and grilles are to be installed for compliance with requirements for installation tolerances and other conditions affecting performance of equipment.
- B. Proceed with installation only after unsatisfactory conditions have been corrected.

3.2 INSTALLATION

- A. Install diffusers, registers, and grilles level and plumb.
- B. Ceiling-Mounted Outlets and Inlets: Drawings indicate general arrangement of ducts, fittings, and accessories. Air outlet and inlet locations have been indicated to achieve design requirements for air volume, noise criteria, airflow pattern, throw, and pressure drop. Make final locations where indicated, as much as practical. For units installed in lay-in ceiling panels, locate units in the center of panel. Where architectural features or other items conflict with installation, notify Architect for a determination of final location.
- C. Install diffusers, registers, and grilles with airtight connections to ducts and to allow service and maintenance of dampers, air extractors, and fire dampers.

3.3 ADJUSTING

- A. After installation, adjust diffusers, registers, and grilles to air patterns indicated, or as directed, before starting air balancing.

END OF SECTION 233713

SECTION 237413 - PACKAGED, OUTDOOR, CENTRAL-STATION AIR-HANDLING UNITS

PART 1 - GENERAL

1.1 RELATED DOCUMENTS

- A. Drawings and general provisions of the Contract, including General and Supplementary Conditions and Division 01 Specification Sections, apply to this Section.

1.2 SUMMARY

- A. This Section includes packaged, outdoor, central-station air-handling units (rooftop units) with the following components and accessories:
 - 1. Direct-expansion cooling.
 - 2. Natural gas furnace.
 - 3. Economizer outdoor- and return-air damper section.
 - 4. Controls.

1.3 DEFINITIONS

- A. DDC: Direct-digital controls.
- B. RTU: Rooftop unit. As used in this Section, this abbreviation means packaged, outdoor, central-station air-handling units. This abbreviation is used regardless of whether the unit is mounted on the roof or on a concrete base on ground.
- C. Supply-Air Fan: The fan providing supply air to conditioned space. "Supply air" is defined as the air entering a space from air-conditioning, heating, or ventilating apparatus.
- D. Supply-Air Refrigerant Coil: Refrigerant coil in the supply-air stream to absorb heat (provide cooling) during cooling operations and to reject heat (provide heating) during heating operations. "Supply air" is defined as the air entering a space from air-conditioning, heating, or ventilating apparatus.

1.4 ACTION SUBMITTALS

- A. Product Data: Include manufacturer's technical data for each RTU, including rated capacities, dimensions, required clearances, characteristics, furnished specialties, and accessories.
- B. Shop Drawings: Detail equipment assemblies and indicate dimensions, weights, loads, required clearances, method of field assembly, components, and location and size of each field connection.
 - 1. Wiring Diagrams: Power, signal, and control wiring.

1.5 INFORMATIONAL SUBMITTALS

- A. Coordination Drawings: Plans and other details, drawn to scale, on which the following items are shown and coordinated with each other, using input from installers of the items involved:
 - 1. Structural members to which RTUs will be attached.
 - 2. Support members and flashing.
- B. Field quality-control test reports.
- C. Warranty: Special warranty specified in this Section.

1.6 CLOSEOUT SUBMITTALS

- A. Operation and Maintenance Data: For RTUs to include in emergency, operation, and maintenance manuals.

1.7 MAINTENANCE MATERIAL SUBMITTALS

- A. Furnish extra materials described below that match products installed and that are packaged with protective covering for storage and identified with labels describing contents.
1. Fan Belts: One set for each belt-driven fan.
 2. Filters: One set of filters for each unit.

1.8 QUALITY ASSURANCE

- A. ARI Compliance:
1. Comply with ARI 203/110 and ARI 303/110 for testing and rating energy efficiencies for RTUs.
 2. Comply with ARI 270 for testing and rating sound performance for RTUs.
- B. ASHRAE Compliance:
1. Comply with ASHRAE 15 for refrigeration system safety.
 2. Comply with ASHRAE 33 for methods of testing cooling and heating coils.
 3. Comply with applicable requirements in ASHRAE 62.1, Section 5 - "Systems and Equipment" and Section 7 - "Construction and Startup."
- C. ASHRAE/IESNA 90.1 Compliance: Applicable requirements in ASHRAE/IESNA 90.1, Section 6 - "Heating, Ventilating, and Air-Conditioning."
- D. NFPA Compliance: Comply with NFPA 90A and NFPA 90B.
- E. UL Compliance: Comply with UL 1995.
- F. Electrical Components, Devices, and Accessories: Listed and labeled as defined in NFPA 70, Article 100, by a testing agency acceptable to authorities having jurisdiction, and marked for intended use.

1.9 WARRANTY

- A. Special Warranty: Manufacturer's standard form in which manufacturer agrees to replace components of RTUs that fail in materials or workmanship within specified warranty period.
1. Warranty Period for Compressors: Manufacturer's standard, but not less than five years from date of Substantial Completion.
 2. Warranty Period for Gas Furnace Heat Exchangers: Manufacturer's standard, but not less than ten years from date of Substantial Completion.
 3. Warranty Period for Solid-State Ignition Modules: Manufacturer's standard, but not less than three years from date of Substantial Completion.
 4. Warranty Period for Control Boards: Manufacturer's standard, but not less than three years from date of Substantial Completion.

PART 2 - PRODUCTS

2.1 MANUFACTURERS

- A. Manufacturers: Subject to compliance with requirements, provide products by one of the following:
1. Daikin (Basis of Design).
 2. Aeon.
 3. Carrier Corporation.
 4. Johnson Controls Inc.
 5. Trane.
- B. General Fabrication Requirements for Casings: Formed and reinforced insulated panels, fabricated to allow removal for access to internal parts and components, with joints between sections sealed.
- C. Exterior Casing Material: Galvanized steel with factory-painted finish, with pitched roof panels and knockouts with grommet seals for electrical and piping connections and lifting lugs.
1. Exterior Casing Thickness: 0.0626 inch thick.
- D. Casing Insulation and Adhesive: Comply with NFPA 90A or NFPA 90B.
1. Materials: ASTM C 1071, Type I.
 2. Thickness: 1/2 inch.
 3. Liner materials shall have air-stream surface coated with an erosion- and temperature-resistant coating or faced with a plain or coated fibrous mat or fabric.
 4. Liner Adhesive: Comply with ASTM C 916, Type I.
- E. Condensate Drain Pans: Formed sections of galvanized-steel sheet, a minimum of 2 inches deep[, and complying with ASHRAE 62.1.
1. Double-Wall Construction: Fill space between walls with foam insulation and seal moisture tight.
 2. Drain Connections: Threaded nipple both sides of drain pan.
- F. Airstream Surfaces: Surfaces in contact with the airstream shall comply with requirements in ASHRAE 62.1.

2.2 FANS

- A. Belt-Driven Supply-Air Fans: Double width, double inlet, forward curved, centrifugal; with permanently lubricated, single-speed motor installed on an adjustable fan base resiliently mounted in the casing. Aluminum or painted-steel wheels, and galvanized- or painted-steel fan scrolls.
- B. Condenser-Coil Fan: Propeller, mounted on shaft of permanently lubricated motor.
- C. Fan Motor: Comply with requirements in Section 230513 "Common Motor Requirements for HVAC Equipment."

2.3 COILS

- A. Supply-Air Refrigerant Coil:
1. Aluminum-plate fin and seamless copper tube in steel casing with equalizing-type vertical distributor.

Weedsport Addition to Maintenance Section and Roof Replacement, MP 304.2

2. Coil Split: Interlaced.
 3. Condensate Drain Pan: Stainless steel formed with pitch and drain connections complying with ASHRAE 62.1.
- B. Outdoor-Air Refrigerant Coil:
1. Aluminum-plate fin and seamless copper tube in steel casing with equalizing-type vertical distributor.

2.4 REFRIGERANT CIRCUIT COMPONENTS

- A. Number of Refrigerant Circuits: Two.
- B. Compressor: Hermetic, scroll, mounted on vibration isolators; with internal overcurrent and high-temperature protection, internal pressure relief, and crankcase heater.
- C. Refrigeration Specialties:
1. Refrigerant: R-410A.
 2. Expansion valve with replaceable thermostatic element.
 3. Refrigerant filter/dryer.
 4. Manual-reset high-pressure safety switch.
 5. Automatic-reset low-pressure safety switch.
 6. Minimum off-time relay.
 7. Automatic-reset compressor motor thermal overload.
 8. Brass service valves installed in compressor suction and liquid lines.
 9. Low-ambient kit high-pressure sensor.

2.5 AIR FILTRATION

- A. Minimum arrestance according to ASHRAE 52.1, and a minimum efficiency reporting value (MERV) according to ASHRAE 52.2.
1. Glass Fiber: Minimum 80 percent arrestance, and MERV 8.

2.6 GAS FURNACE

- A. Description: Factory assembled, piped, and wired; complying with ANSI Z21.47 and NFPA 54.
1. CSA Approval: Designed and certified by and bearing label of CSA.
- B. Burners: Stainless steel.
1. Fuel: Natural gas.
 2. Ignition: Electronically controlled electric spark or hot-surface igniter with flame sensor.
- C. Heat-Exchanger and Drain Pan: Stainless steel.
- D. Power Vent: Integral, motorized centrifugal fan interlocked with gas valve, and with vertical extension.
- E. Safety Controls:
1. Gas Control Valve: Modulating, with a 2.5:1 turndown.
 2. Gas Train: Single-body, regulated, redundant, 24-V ac gas valve assembly containing pilot solenoid valve, pilot filter, pressure regulator, pilot shutoff, and manual shutoff.

Weedsport Addition to Maintenance Section and Roof Replacement, MP 304.2

2.7 DAMPERS

- A. Outdoor- and Return-Air Mixing Dampers: Parallel- or opposed-blade galvanized-steel dampers mechanically fastened to cadmium plated for galvanized-steel operating rod in reinforced cabinet. Connect operating rods with common linkage and interconnect linkages so dampers operate simultaneously.
 - 1. Damper Motor: Modulating with adjustable minimum position.
 - 2. Relief-Air Damper: Gravity actuated, as required by ASHRAE/IESNA 90.1, with bird screen and hood.

2.8 ELECTRICAL POWER CONNECTION

- A. Provide for single connection of power to unit with unit-mounted disconnect switch accessible from outside unit and control-circuit transformer with built-in overcurrent protection.

2.9 CONTROLS

- A. Provide microprocessor unit-mounted DDC control which when used with an electronic zone sensor provides proportional integral room control. This UCM shall perform all unit functions by making all heating, cooling, and ventilating decisions through resident software logic.
- B. Provide factory-installed indoor evaporator defrost control to prevent compressor slugging by interrupting compressor operation.
- C. Provide an anti-cycle timing and minimum on/off between stages timing in the microprocessor.
- D. Enthalpy Economizer Preferred Cooling - Compressor operation is integrated with economizer cycle to allow mechanical cooling when economizer is not adequate to satisfy zone requirements. Compressors are enabled if space temperature is recovering to cooling setpoint at a rate of less than 0.2 degrees per minute. Compressor low ambient lockout overrides this function.
- E. Control Functions: Include unit scheduling, occupied/unoccupied mode, start-up and coast-down modes, nighttime free-cool purge mode, demand limiting, night setback, discharge air set point adjustment, timed override and alarm shutdown.
- F. Provide capabilities for Boolean Processing and trend logs as well as "templated" reports and logs.

2.10 SINGLE ZONE VARIABLE AIR VOLUME (SZVAV)

- A. Unit shall be provided with VFD (Variable Frequency Drive) on Indoor fan motor. VFD shall change fan speed according to mode of operation. During cooling mode, fan shall modulate to maintain space temperature. The compressor shall operate to control discharge air temperature. This operation shall be standard with SZVAV offering. During heating operation, single zone control will be allowed with modulating gas heat only. All other heat operations shall be as constant volume heating control.
- B. Unit shall be provided with shaft grounding rings for electrical protection. Shaft grounding rings provide long term motor/VFD bearing reliability.
- C. Multi-Speed Indoor fan System: Unit shall be provided with indoor fan system designed for use in applications for meeting the minimum requirements of CA Title 24. This system incorporates

Weedsport Addition to Maintenance Section and Roof Replacement, MP 304.2

a multi-speed fan control to change speed of the fan to 67% of full airflow based off of compressor stages.

2.11 ACCESSORIES

- A. Duplex, 115-V, ground-fault-interrupter outlet with 15-A overcurrent protection. Include transformer if required. Outlet shall be energized even if the unit main disconnect is open.
- B. Coil guards of painted, galvanized-steel wire.

PART 3 - EXECUTION**3.1 EXAMINATION**

- A. Examine substrates, areas, and conditions, with Installer present, for compliance with requirements for installation tolerances and other conditions affecting performance of RTUs.
- B. Examine roughing-in for RTUs to verify actual locations of piping and duct connections before equipment installation.
- C. Examine roofs for suitable conditions where RTUs will be installed.
- D. Proceed with installation only after unsatisfactory conditions have been corrected.

3.2 INSTALLATION

- A. Install on new support rails and secure.

3.3 CONNECTIONS

- A. Install condensate drain, minimum connection size, with trap and indirect connection to nearest roof drain or area drain.
- B. Install piping adjacent to RTUs to allow service and maintenance.
 - 1. Natural Gas Piping: Connect gas piping to burner, full size of gas connection, and connect with union and shutoff valve with sufficient clearance for burner removal and service.

3.4 FIELD QUALITY CONTROL

- A. Manufacturer's Field Service: Engage a factory-authorized service representative to inspect, test, and adjust components, assemblies, and equipment installations, including connections. Report results in writing.
- B. Perform tests and inspections and prepare test reports.
 - 1. Manufacturer's Field Service: Engage a factory-authorized service representative to inspect components, assemblies, and equipment installations, including connections, and to assist in testing. Report results in writing.
- C. Tests and Inspections:
 - 1. After installing RTUs and after electrical circuitry has been energized, test units for compliance with requirements.
 - 2. Inspect for and remove shipping bolts, blocks, and tie-down straps.

Weedsport Addition to Maintenance Section and Roof Replacement, MP 304.2

3. Operational Test: After electrical circuitry has been energized, start units to confirm proper motor rotation and unit operation.
 4. Test and adjust controls and safeties. Replace damaged and malfunctioning controls and equipment.
- D. Remove and replace malfunctioning units and retest as specified above.

3.5 STARTUP SERVICE

- A. Engage a factory-authorized service representative to perform startup service.
- B. Complete installation and startup checks according to manufacturer's written instructions and do the following:
 1. Inspect for visible damage to unit casing.
 2. Inspect for visible damage to furnace combustion chamber.
 3. Inspect for visible damage to compressor, coils, and fans.
 4. Inspect internal insulation.
 5. Verify that labels are clearly visible.
 6. Verify that clearances have been provided for servicing.
 7. Verify that controls are connected and operable.
 8. Verify that filters are installed.
 9. Clean condenser coil and inspect for construction debris.
 10. Clean furnace flue and inspect for construction debris.
 11. Connect and purge gas line.
 12. Remove packing from vibration isolators.
 13. Inspect operation of barometric relief dampers.
 14. Verify lubrication on fan and motor bearings.
 15. Inspect fan-wheel rotation for movement in correct direction without vibration and binding.
 16. Adjust fan belts to proper alignment and tension.
 17. Start unit according to manufacturer's written instructions.
 - a. Start refrigeration system.
 - b. Do not operate below recommended low-ambient temperature.
 - c. Complete startup sheets and attach copy with Contractor's startup report.
 18. Inspect and record performance of interlocks and protective devices; verify sequences.
 19. Operate unit for an initial period as recommended or required by manufacturer.
 20. Perform the following operations for both minimum and maximum firing. Adjust burner for peak efficiency.
 - a. Measure gas pressure on manifold.
 - b. Inspect operation of power vents.
 - c. Measure combustion-air temperature at inlet to combustion chamber.
 - d. Measure flue-gas temperature at furnace discharge.
 - e. Perform flue-gas analysis. Measure and record flue-gas carbon dioxide and oxygen concentration.
 - f. Measure supply-air temperature and volume when burner is at maximum firing rate and when burner is off. Calculate useful heat to supply air.
 21. Adjust and inspect high-temperature limits.
 22. Inspect outdoor-air dampers for proper stroke and interlock with return-air dampers.

Weedsport Addition to Maintenance Section and Roof Replacement, MP 304.2

23. Start refrigeration system and measure and record the following when ambient is a minimum of 15 deg F above return-air temperature:
 - a. Coil leaving-air, dry- and wet-bulb temperatures.
 - b. Coil entering-air, dry- and wet-bulb temperatures.
 - c. Outdoor-air, dry-bulb temperature.
 - d. Outdoor-air-coil, discharge-air, dry-bulb temperature.
24. Inspect controls for correct sequencing of heating, mixing dampers, refrigeration, and normal and emergency shutdown.
25. Measure and record the following minimum and maximum airflows. Plot fan volumes on fan curve.
 - a. Supply-air volume.
 - b. Return-air volume.
 - c. Relief-air volume.
 - d. Outdoor-air intake volume.
26. Simulate maximum cooling demand and inspect the following:
 - a. Compressor refrigerant suction and hot-gas pressures.
 - b. Short circuiting of air through condenser coil or from condenser fans to outdoor-air intake.
27. Verify operation of remote panel including pilot-light operation and failure modes. Inspect the following:
 - a. High-temperature limit on gas-fired heat exchanger.
 - b. Low-temperature safety operation.
 - c. Filter high-pressure differential alarm.
 - d. Economizer to minimum outdoor-air changeover.
 - e. Relief-air fan operation.
 - f. Smoke and firestat alarms.
28. After startup and performance testing and prior to Substantial Completion, replace existing filters with new filters.

3.6 CLEANING AND ADJUSTING

- A. Occupancy Adjustments: When requested within 12 months of date of Substantial Completion, provide on-site assistance in adjusting system to suit actual occupied conditions. Provide up to two visits to site during other-than-normal occupancy hours for this purpose.
- B. After completing system installation and testing, adjusting, and balancing RTU and air-distribution systems, clean filter housings and install new filters.

3.7 DEMONSTRATION

- A. Engage a factory-authorized service representative to train Owner's maintenance personnel to adjust, operate, and maintain RTUs.

END OF SECTION 237413

ITEM 627.0026 25**ELECTRICAL****1. DESCRIPTION:**

- 1.01 Furnish all labor, materials, equipment and services necessary to complete the work as indicated on the Contract Plans and the attached Specification Summary.
- 1.02 All work shall conform to the requirements specified in Part 1 – General, of the Sections listed.

2. MATERIALS:

- 2.01 The materials shall be as specified in Part 2 – Products, of the Sections listed.

3. CONSTRUCTION DETAILS:

- 3.01 The construction details shall be as specified on Part 3 – Execution, if the Sections listed.

4. METHOD OF MEASUREMENT:

- 4.01 This item shall be measured for payment on a lump sum basis for the work completed in accordance with the Contract Documents and as directed by the Engineer.

5. BASIS OF PAYMENT:

- 5.01 Payment for this item shall be made at the lump sum bid price bid. The lump sum price bid shall include cost of furnishing all labor, material, equipment and appliances necessary to complete the work as indicated on the Contract Plans and as specified herein in the Sections listed.
- 5.02 Detailed Estimate:
 - A. Before the first certificate of payment is issued for the work under this item, submit a detailed estimate of quantities and prices for all materials, labor, and other items included under this item, which shall aggregate the contract lump sum price bid for this item. Prepare the detailed estimate in the same sequence as the Sections listed.
 - B. The detailed estimate shall be supported by such evidence, including certified copies of subcontracts, as the Engineer may require.
 - C. The detailed estimate must be approved by the Engineer who may revise it as, in his/her reasonable judgment, is necessary to make the various item conform to their true values. The value of each certificate of payment will be based on the approved detailed estimate.
- 5.03 Monthly payments will be made for this item in proportion to the total amount of work completed.

ITEM 627.0026 25**ELECTRICAL****1. SPECIFICATION SUMMARY**

1.01 This Item includes the following specifications:

- A. Section 260000 GENERAL PROVISIONS FOR ELECTRICAL WORK
- B. Section 260519 LOW-VOLTAGE CONDUCTORS AND CABLES
- C. Section 260526 GROUNDING AND BONDING
- D. Section 260529 HANGERS AND SUPPORTS FOR ELECTRICAL SYSTEMS
- E. Section 260533 RACEWAY AND BOXES
- F. Section 260544 SLEEVES AND SLEEVE SEALS FOR ELECTRICAL
RACEWAYS & CABLING
- G. Section 260553 ELECTRICAL IDENTIFICATION
- H. Section 260923 LIGHTING CONTROL DEVICES
- I. Section 262616 ENCLOSED SWITCHES AND CIRCUIT BREAKERS
- J. Section 262726 WIRING DEVICES
- K. Section 265100 INTERIOR LIGHTING

1.02 This item shall include, but not be limited to, the following:

- A. Lighting and control devices for the building's addition
- B. Raceways, boxes, and other electrical components needed for the building's addition

SECTION 260000 – GENERAL PROVISIONS FOR ELECTRICAL WORK

PART 1 - GENERAL

1.1 SCOPE OF WORK

- A. The work included in this Contract is shown on the drawings and described in these specifications. It consists of furnishing all labor, material, services, supervision and connection of all systems shown and/or specified including the requirements of:

DIVISION	0	-	BIDDING AND CONTRACT REQUIREMENTS
DIVISION	1	-	GENERAL REQUIREMENTS
DIVISION	26	-	ELECTRICAL

- B. Contractor is responsible to review and understand all drawings and all work of all trades to ensure a complete and thorough project.
- C. Provide all labor, tools, materials, equipment, coordination, and plans necessary for installation and proper operation of the electrical systems.
- D. Contract drawings and specifications are complementary and must be so used to ascertain all requirements of the work.

1.2 DEFINITIONS

- A. Provide, furnish, install, and furnish and install shall have the same meaning. That is, the Contractor shall purchase, transport to the site and install all required components of the work unless specifically stated otherwise in the contract documents.
- B. Wiring pertains to raceway, fittings, conductors, terminations, hangers, supports, etc. as required to form a complete system.

1.3 DRAWINGS AND SPECIFICATIONS

- A. The plans are diagrammatic and indicate only the sizes and general arrangement of conduit, devices, and equipment; exact locations of all elements shall be determined as work progresses, in cooperation with the work of other trades. It is not intended to show every item of work or minor piece of equipment, but every item shall be furnished and installed without additional remuneration as necessary to complete the system in accordance with the best practice of the trade.
- B. As previously stated, the exact locations of electrical devices and equipment is diagrammatic. The owner may request for any devices or equipment to be installed at different locations than what is indicated on the drawings in a specific area or room. It is the responsibility of the Electrical Contractor to coordinate the locations of devices in all areas prior to installation.

1.4 APPLICABLE STANDARDS

- A. All equipment shall bear the UL label.
- B. The latest edition of the following minimum standards shall apply wherever applicable:

ASA	American Standards Association
ASTM	American Society for Testing Materials

Weedsport Addition to Maintenance Section and Roof Replacement, MP 304.2

ETL	Electrical Testing Laboratories, Inc.
IEEE	Institute of Electrical and Electronic Engineers
IPCEA	Insulated Power Cable for Engineers Association
OSHA	Occupational Safety and Health Act
NEC	National Electric Code
NEMA	National Electrical Manufacturers Association
NESC	National Electrical Safety Code
NFPA	National Fire Protection Association
UL	Underwriters Laboratories, Inc.
	Power company standards and regulations.
	Local and state codes.

- C. In the event there are conflicts between specifications and standards, standards shall govern unless specifications are in excess of standards.

1.5 PERMITS AND INSPECTIONS

- A. Permits: The Contractor shall apply for and pay the cost for any local permits necessary for the work of this contract.
- B. Inspections: The Contractor shall be responsible for obtaining inspection of and the certificate by a 3rd party inspection agency for the entire electrical system. Turn over certificate of inspection to the architect.
- C. The undertaking of periodic inspections by the Owner or Engineer shall not be construed as supervision of actual construction. The Owner or Engineer is not responsible for providing a safe place of work for the Contractor, Contractor's employees, suppliers or subcontractors for access, visits, use, work, travel or occupancy by any person.

1.6 CODES AND REGULATIONS

- A. Comply with all applicable rules and regulations of the municipal laws and ordinances and latest revisions thereof. All work shall be done in full conformity with the requirements of all authorities having jurisdiction. Modifications required by the above authorities will be made without additional charges to the Owner. Where alterations to and/or deviations from the Contract Documents are required by the authorities, report the requirements to the Engineer and secure approval before work is started.
- B. Furnish and file with the proper authorities, all drawings required by them in connection with the work. Obtain all permits, licenses, and inspections and pay all legal and proper fees and charges in this connection.
- C. Should any work shown or specified be of lighter or smaller material than Code requires, same shall be executed in strict accordance with the regulations.
- D. Heavier or larger size material than Code requires shall be furnished and installed, if required by the Plans and Specifications.
- E. This Contractor shall have the electrical work inspected from time to time by authorized inspectors and shall pay all expense incurred by same. At the completion of the work, the Contractor shall furnish a Certificate of Approval, in triplicate, indicating full approval of the work furnished and installed in this Contract from the local authority having jurisdiction.
- F. Equipment and components parts thereof shall bear manufacturer's name-plate, giving manufacturer's name, size, type and model number or serial number, electrical characteristic to

Weedsport Addition to Maintenance Section and Roof Replacement, MP 304.2

facilitate maintenance and replacements. Name plates of distributors or contractors are not acceptable.

- G. Engineer will have privilege of stopping any work or use of any material that in his opinion is not being properly installed and each Contractor shall remove all materials delivered, or work erected, which does not comply with Contract Drawings and Specifications, and replace with proper materials, or correct such work as directed by the Engineer, at no additional cost to Owner.
- H. If equipment or materials are installed before proper approvals have been obtained, each Contractor shall be liable for their removal and replacement including work of other trades affected by such work, at no additional cost to Owner, if such items do not meet intent of the Drawings and Specifications.

1.7 RECORD DRAWINGS

- A. The Electrical Contractor shall keep an accurate location record of all underground and concealed piping, and of all changes from the original design. He is required to furnish this information to the Engineer prior to his application for final payment.
 - 1. Submit prior to final acceptance inspection, one complete marked-up set of reproducible engineering design drawings.
 - a. Fully illustrate all revisions made by all crafts in course of work.
 - b. Include all field changes, adjustments, variances, substitutions and deletions, including all Change Orders.
 - c. Exact location of raceways, equipment and devices.
 - d. Exact size and location of underground and under floor raceways, grounding conductors and duct banks.
 - 2. These drawings shall be for record purposes for Owner's use and are not considered shop drawings.
- B. At completion of the project, all changes and deviations from the Contract Documents shall be recorded by the Contractor.
- C. Four (4) corrected sets of all operating and maintenance instructions and complete parts lists bound in hard covers shall be furnished to the Owner.

1.8 CLEANING CONDUIT AND EQUIPMENT

- A. Conduit and electrical equipment shall be thoroughly cleaned of dirt, cuttings, and other foreign substances.

1.9 VIBRATION ISOLATION

- A. Vibration isolators shall prevent, as far as practicable, transmission of vibration, noise or hum to any part of building.
- B. Wiring and other electrical connections to equipment mounted on vibration isolators; made flexible with minimum 180 degree loop of "greenfield" in order to avoid restraining equipment and short circuiting vibration isolator.

1.10 BALANCED LOAD

- A. It is intended that design and features of the work as indicated will provide balanced load on the feeders and main service. Contractor shall provide material and installation to provide this balance load insofar as possible.

Weedsport Addition to Maintenance Section and Roof Replacement, MP 304.2

- B. Contractor shall take current and voltage measurements at all panels of at least 1/2 hour. Reconnections of loads shall be made when deemed necessary by the Engineers.

1.11 JOB CONDITIONS

- A. Examine site related work and surfaces before starting work of any Section. Failure to do so shall in no way relieve the Contractor of the responsibility to properly install the new work.
1. Report to the Engineer, in writing, conditions, which will prevent proper provision of this work ten (10) days prior to bid date, in time for an addendum to be issued .
 2. Beginning work of any Section without reporting unsuitable conditions to the Engineer constitutes acceptance of conditions by the Contractor.
 3. Perform any required removal, repair or replacement of this work caused by unsuitable conditions at no additional cost to Owner.
 4. The Contractor is responsible for performing routine maintenance and cleaning of any existing equipment where he is making connections to new work and to the building where his work adds debris.
- B. Connections to existing work:
1. Install new work and connect to existing work with minimum interference to existing facilities.
 2. Provide temporary shutdowns of existing services only with written consent of Owner at no additional charges and at time not to interfere with normal operation of existing facilities.
 3. Maintain continuous operation of existing facilities as required with necessary temporary connections between new and existing work.
 4. Do not interrupt alarm and emergency systems.
 5. Connect new work to existing work in neat and acceptable manner.
 6. Restore existing disturbed work to original condition including maintenance of wiring and continuity as required. Replace damaged or rusted conduit to which new equipment is being installed and connected.
- C. Removal and relocation of existing work.
1. Disconnect, remove or relocate electrical material, equipment and other work noted and required by removal or changes in existing construction.
 2. Provide new material and equipment required for relocated equipment.
 3. Disconnect load and line end of conductors feeding existing equipment.
 4. Remove conductors from existing raceways to be rewired.
 5. Remove conductors and cap outlets on raceways to be abandoned.
 6. Dispose of removed raceways and wire.
 7. Dispose of removed electrical equipment as directed by Owner. The Owner shall provide a list of equipment of the Contractor of equipment to be delivered to the Owner.

1.12 SPECIAL TOOLS AND LOOSE ITEMS

- A. Furnish to Owner at completion of work:
1. One set of any special tools required to operate, adjust, dismantle or repair equipment furnished under any section of this Division.
 2. "Special Tools": Those not normally found in possession of maintenance personnel.
 3. Keys
 4. Redundant components and spare parts.
- B. Deliver items to Owner and obtain receipt prior to approval of final payment.

Weedsport Addition to Maintenance Section and Roof Replacement, MP 304.2

1.13 REVIEW OF CONSTRUCTION

- A. Work may be reviewed at any time by representative of the Engineer.
- B. Advise Architect and Engineer that work is ready for review at following times:
 - 1. Prior to backfilling buried work.
 - 2. Prior to concealment of work in walls and above ceilings.
 - 3. When all requirements of contract have been completed.
- C. Neither backfill nor conceal work without Engineer's consent.

1.14 SHOP DRAWING SUBMITTALS

- A. Submit required shop drawings, samples and product information in accordance with Division 1 requirements and as required in the various sections of these specifications.
- B. Submittals shall show evidence of checking by the Contractor for accuracy. Product information (catalog sheets) shall indicate complete catalog number, color, accessories, etc., as well as, name of manufacturer and local distributor or manufacturer's representative.
- C. Submit for review detailed coordination drawings 3/8" or larger scale plans for all major electrical equipment and any areas of conflicts by drafting location of equipment, lighting fixtures, cable trays and conduits larger than 1-1/2" trade size. Contractor shall refer to Division 1 for preparing coordination drawings.
- D. Incomplete submittals will be rejected.
- E. Additionally, the Contractor will submit data on the following:
 - 1. All electrical equipment including all panelboards and switching devices (disconnects, switches, occupancy sensors, etc.).
 - 2. Fire stop seals used for wall penetrations.
 - 3. Any proposed variation in specified wiring plans and circuitry.
 - 4. All special items and panels, made or constructed specifically for this project, including wiring diagrams, component layout and component data or materials list.
 - 5. All settings of installed equipment, such as overcurrent protection, overload settings, temperature settings, time settings, etc. This includes equipment provided by other contractors or subcontractors and connected and tested by this Contractor.
- F. All submittals of NON-SPECIFIED equipment and components will be reviewed. It is the submitting Contractor's responsibility to prove compliance and not the Architect/Engineer to prove non-compliance. The submitting Contractor will be charged the prevailing wage of the reviewing Engineer for all submittals requiring over one (1) hour to review that were not originally specified.

1.15 OPERATING INSTRUCTIONS

- A. It shall be the Contractor's responsibility to insure that the Owner's representative is given adequate instruction on the operation of all equipment prior to final payment.

1.16 TEMPORARY POWER

- A. The Contractor shall provide all temporary power to all trades for all construction locations of this contract. This will include but not be limited to temporary lighting and power outlets.

PART 2 - PRODUCTS**2.1 MATERIALS**

- A. All materials and equipment shall be new and as specified or of equal or better quality.
- B. Basic hardware and miscellaneous items shall meet existing trade standards of quality and shall carry UL or FM listings where applicable.
- C. All equipment supplied shall be the standard equipment of the manufacturer.
- D. Multiple items such as panelboards, wiring devices, switches, breakers, raceways, etc., shall be from the same manufacturer.
- E. Drawings and specifications are based on specific manufacturer's equipment. Therefore, the Contractor shall assume all responsibility, cost and coordination involved in making any necessary revisions to apply another manufacturer's equipment, even though it may be approved as an "equal" item by the Engineer.

PART 3 - EXECUTION**3.1 COORDINATION OF WORK**

- A. All work shall be executed in accordance with recognized standards of workmanship. All work shall be installed in a neat and orderly manner.
- B. The Contractor shall exchange information with other Contractors and the Owner in order to insure orderly progress of the work.
- C. The Contractor must contact the Owner's representative and schedule all work ten (10) days prior to start.
- D. The Contractor shall check for possible interference before installing any items. If any work is installed, and later develops interference with other features of the design, the Contractor will be responsible to make such changes to eliminate the interference.

3.2 CEILING REMOVAL

- A. Existing ceilings which must be removed for the installation of new work or demolition of existing conditions shall be done by the Contractor. No ceiling shall be removed without prior approval of the Owner. Ceilings which must be removed shall be restored to their original condition as soon as practical and prior to final payment.
- B. The removed tile of lay-in type ceilings shall be stored either in the ceiling space or at a designated space in the building. No tiles shall be stored in the occupied space.
- C. The Contractor shall take all necessary precautions to prevent damage to the existing ceilings. All damaged ceilings shall be replaced with new ceiling construction to match the existing and to the Owner's satisfaction.

3.3 COMMON REQUIREMENTS FOR ELECTRICAL INSTALLATION

- A. Comply with NECA 1.
- B. Measure indicated mounting heights to bottom of unit for suspended items and to center of unit for wall-mounting items.

Weedsport Addition to Maintenance Section and Roof Replacement, MP 304.2

- C. Headroom Maintenance: If mounting heights or other location criteria are not indicated, arrange and install components and equipment to provide maximum possible headroom consistent with these requirements.
- D. Equipment: Install to facilitate service, maintenance, and repair or replacement of components of both electrical equipment and other nearby installations. Connect in such a way as to facilitate future disconnecting with minimum interference with other items in the vicinity.
- E. Right of Way: Give to piping systems installed at a required slope.

3.4 FIRESTOPPING

- A. Apply firestopping to penetrations of fire-rated floor and wall assemblies for electrical installations to restore original fire-resistance rating of assembly. Firestopping materials and installation requirements are specified in Division 7 Section "Through-Penetration Firestop Systems."

END OF SECTION 260000

THIS PAGE INTENTIONALLY LEFT BLANK

SECTION 260519 – LOW-VOLTAGE CONDUCTORS AND CABLES

PART 1 - GENERAL

1.1 SUMMARY

- A. This Section includes building wires and cables and associated connectors, splices, and terminations for wiring systems rated 600 V and less.

1.2 SUBMITTALS

- A. Field Test Reports: Indicate and interpret test results for compliance with performance requirements.

1.3 QUALITY ASSURANCE

- A. Testing Agency Qualifications: In addition to requirements specified in Division 1, an independent testing agency shall meet OSHA criteria for accreditation of testing laboratories, Title 29, Part 1907; or shall be a full-member company of the InterNational Electrical Testing Association.
1. Testing Agency's Field Supervisor: Person currently certified by the InterNational Electrical Testing Association or the National Institute for Certification in Engineering Technologies, to supervise on-site testing specified in Part 3.
- B. Listing and Labeling: Provide wires and cables specified in this Section that are listed and labeled.
1. The Terms "Listed" and "Labeled": As defined in NFPA 70, Article 100.
 2. Listing and Labeling Agency Qualifications: A "Nationally Recognized Testing Laboratory" as defined in OSHA Regulation 1910.7.
- C. Comply with NFPA 70.

1.4 DELIVERY, STORAGE, AND HANDLING

- A. Deliver wires and cables according to NEMA WC 26.

1.5 COORDINATION

- A. Coordinate layout and installation of cables with other installations.
- B. Revise locations and elevations from those indicated, as required to suit field conditions and as approved by Architect.

PART 2 - PRODUCTS

2.1 MANUFACTURERS

- A. Manufacturers: Subject to compliance with requirements, provide products by one of the following:
1. Wires and Cables:
 - a. Okonite
 - b. American Insulated Wire Corp.; Leviton Manufacturing Co.
 - c. BICC Brand-Rex Company.
 - d. Southwire Company.
 2. Connectors for Wires and Cables:
 - a. General Signal; O-Z/Gedney Unit.

Weedsport Addition to Maintenance Section and Roof Replacement, MP 304.2

- b. Square D Co.; Anderson.
- c. 3M Company; Electrical Products Division.

2.2 BUILDING WIRES AND CABLES

- A. UL-listed building wires and cables with conductor material, insulation type, cable construction, and rating as specified in Part 3 "Wire and Insulation Applications" Article.
- B. Rubber Insulation Material: Comply with NEMA WC 3.
- C. Thermoplastic Insulation Material: Comply with NEMA WC 5.
- D. Cross-Linked Polyethylene Insulation Material: Comply with NEMA WC 7.
- E. Ethylene Propylene Rubber Insulation Material: Comply with NEMA WC 8.
- F. Conductor Material: Copper.
- G. Stranded conductors.

2.3 CONNECTORS AND SPLICES

- A. UL-listed, factory-fabricated wiring connectors of size, ampacity rating, material, type, and class for application and service indicated. Comply with Project's installation requirements and as specified in Part 3 "Wire and Insulation Applications" Article.

PART 3 - EXECUTION**3.1 EXAMINATION**

- A. Examine raceways and building finishes to receive wires and cables for compliance with requirements for installation tolerances and other conditions affecting performance of wires and cables. Do not proceed with installation until unsatisfactory conditions have been corrected.

3.2 WIRE AND INSULATION APPLICATIONS

- A. Feeders: Type THHN/THWN, in raceway.
- B. Branch Circuits: Type THHN/THWN, in raceway.
- C. Class 1 Control Circuits: Type THHN/THWN, in raceway.
- D. Class 2 Control Circuits: Type THHN/THWN, in raceway.

3.3 INSTALLATION

- A. Install wires and cables as indicated, according to manufacturer's written instructions and NECA's "Standard of Installation."
- B. Remove existing wires from raceway before pulling in new wires and cables.
- C. Pull Conductors: Use manufacturer-approved pulling compound or lubricant where necessary; compound used must not deteriorate conductor or insulation. Do not exceed manufacturer's recommended maximum pulling tensions and sidewall pressure values.
- D. Use pulling means, including fish tape, cable, rope, and basket-weave wire/cable grips, that will not damage cables or raceway.
- E. Install exposed cables, parallel and perpendicular to surfaces of exposed structural members, and follow surface contours where possible.

Weedsport Addition to Maintenance Section and Roof Replacement, MP 304.2

- F. Support cables according to Division 26 Section "Basic Electrical Materials and Methods."
- G. Seal around cables penetrating fire-rated elements according to Division 7 Section "Firestopping."
- H. Identify wires and cables according to Division 16 Section "Electrical Identification."

3.4 CONNECTIONS

- A. Conductor Splices: Keep to minimum.
- B. Install splices and tapes that possess equivalent or better mechanical strength and insulation ratings than conductors being spliced.
- C. Use splice and tap connectors compatible with conductor material.
- D. Wiring at Outlets: Install conductor at each outlet, with at least 12 inches of slack.
- E. Connect outlets and components to wiring and to ground as indicated and instructed by manufacturer.
- F. Tighten electrical connectors and terminals according to manufacturer's published torque-tightening values. If manufacturer's torque values are not indicated, use those specified in UL 486A and UL 486B.

3.5 FIELD QUALITY CONTROL

- A. Testing: On installation of wires and cables and before electrical circuitry has been energized, demonstrate product capability and compliance with requirements.
 - 1. Procedures: Perform each visual and mechanical inspection and electrical test stated in NETA ATS, Section 7.3.1. Certify compliance with test parameters.
- B. Correct malfunctioning conductors and cables at Project site, where possible, and retest to demonstrate compliance; otherwise, remove and replace with new units and retest.

END OF SECTION 260519

THIS PAGE INTENTIONALLY LEFT BLANK

SECTION 260526 - GROUNDING AND BONDING

PART 1 - GENERAL

1.1 SUMMARY

- A. Section Includes: Grounding systems and equipment.
- B. Section includes grounding systems and equipment, plus the following special applications:
 - 1. Overhead-line grounding.
 - 2. Underground distribution grounding.

1.2 ACTION SUBMITTALS

- A. Product Data: For each type of product indicated.

1.3 INFORMATIONAL SUBMITTALS

- A. Informational Submittals: Plans showing dimensioned as-built locations of grounding features specified in "Field Quality Control" Article, including the following:
 - 1. Test wells.
 - 2. Ground rods.
 - 3. Ground rings.
 - 4. Grounding arrangements and connections for separately derived systems.
 - 5. Grounding for sensitive electronic equipment.
- B. Qualification Data: For qualified testing agency and testing agency's field supervisor.
- C. Field quality-control reports.

1.4 CLOSEOUT SUBMITTALS

- A. Operation and Maintenance Data: For grounding to include in emergency, operation, and maintenance manuals. In addition, include the following:
 - 1. Instructions for periodic testing and inspection of grounding features at test wells, ground rings, and grounding connections for separately derived systems based on NFPA 70B.
 - a. Tests shall determine if ground-resistance or impedance values remain within specified maximums, and instructions shall recommend corrective action if values do not.
 - b. Include recommended testing intervals.

1.5 QUALITY ASSURANCE

- A. Testing Agency Qualifications: Member company of NETA or an NRTL.
 - 1. Testing Agency's Field Supervisor: Currently certified by NETA to supervise on-site testing.
- B. Electrical Components, Devices, and Accessories: Listed and labeled as defined in NFPA 70, by a qualified testing agency, and marked for intended location and application.
- C. Comply with UL 467 for grounding and bonding materials and equipment.

PART 2 - PRODUCTS

2.1 CONDUCTORS

- A. Insulated Conductors: Copper wire or cable insulated for 600 V unless otherwise required by applicable Code or authorities having jurisdiction.
- B. Bare Copper Conductors:
 - 1. Solid Conductors: ASTM B 3.
 - 2. Stranded Conductors: ASTM B 8.
 - 3. Tinned Conductors: ASTM B 33.
 - 4. Bonding Cable: 28 kcmil, 14 strands of No. 17 AWG conductor, 1/4 inch in diameter.
 - 5. Bonding Conductor: No. 4 or No. 6 AWG, stranded conductor.
 - 6. Bonding Jumper: Copper tape, braided conductors terminated with copper ferrules; 1-5/8 inches wide and 1/16 inch thick.
 - 7. Tinned Bonding Jumper: Tinned-copper tape, braided conductors terminated with copper ferrules; 1-5/8 inches wide and 1/16 inch thick.
- C. Bare Grounding Conductor and Conductor Protector for Wood Poles:
 - 1. No. 4 AWG minimum, soft-drawn copper.
 - 2. Conductor Protector: Half-round PVC or wood molding; if wood, use pressure-treated fir, cypress, or cedar.
- D. Grounding Bus: Predrilled rectangular bars of annealed copper, 1/4 by 4 inches in cross section, with 9/32-inch holes spaced 1-1/8 inches apart. Stand-off insulators for mounting shall comply with UL 891 for use in switchboards, 600 V. Lexan or PVC, impulse tested at 5000 V.

2.2 CONNECTORS

- A. Listed and labeled by an NRTL acceptable to authorities having jurisdiction for applications in which used and for specific types, sizes, and combinations of conductors and other items connected.
- B. Bolted Connectors for Conductors and Pipes: Copper or copper alloy, pressure type with at least two bolts.
 - 1. Pipe Connectors: Clamp type, sized for pipe.
- C. Welded Connectors: Exothermic-welding kits of types recommended by kit manufacturer for materials being joined and installation conditions.
- D. Bus-bar Connectors: Mechanical type, cast silicon bronze, solderless compression type wire terminals, and long-barrel, two-bolt connection to ground bus bar.

2.3 GROUNDING ELECTRODES

- A. Ground Rods: Copper-clad steel, sectional type; 3/4 inch by 10 feet in diameter.
- B. Chemical-Enhanced Grounding Electrodes: Copper tube, straight or L-shaped, charged with nonhazardous electrolytic chemical salts.
 - 1. Termination: Factory-attached No. 4/0 AWG bare conductor at least 48 inches long.
 - 2. Backfill Material: Electrode manufacturer's recommended material.

PART 3 - EXECUTION

3.1 APPLICATIONS

- A. Conductors: Install solid conductor for No. 8 AWG and smaller, and stranded conductors for No. 6 AWG and larger unless otherwise indicated.
- B. Underground Grounding Conductors: Install bare tinned-copper conductor, No. 2/0 AWG minimum.
 - 1. Bury at least 24 inches below grade.
 - 2. Duct-Bank Grounding Conductor: Bury 12 inches above duct bank when indicated as part of duct-bank installation.
- C. Grounding Bus: Install in electrical and telephone equipment rooms, in rooms housing service equipment, and elsewhere as indicated.
 - 1. Install bus on insulated spacers 2 inches minimum from wall, 6 inches above finished floor unless otherwise indicated.
 - 2. Where indicated on both sides of doorways, route bus up to top of door frame, across top of doorway, and down to specified height above floor; connect to horizontal bus.
- D. Conductor Terminations and Connections:
 - 1. Pipe and Equipment Grounding Conductor Terminations: Bolted connectors.
 - 2. Underground Connections: Welded connectors except at test wells and as otherwise indicated.
 - 3. Connections to Ground Rods at Test Wells: Bolted connectors.
 - 4. Connections to Structural Steel: Welded connectors.

3.2 GROUNDING OVERHEAD LINES

- A. Comply with IEEE C2 grounding requirements.
- B. Install two parallel ground rods if resistance to ground by a single, ground-rod electrode exceeds 25 ohms.
- C. Drive ground rods until tops are 12 inches below finished grade in undisturbed earth.
- D. Ground-Rod Connections: Install bolted connectors for underground connections and connections to rods.
- E. Lightning Arrester Grounding Conductors: Separate from other grounding conductors.
- F. Secondary Neutral and Transformer Enclosure: Interconnect and connect to grounding conductor.
- G. Protect grounding conductors running on surface of wood poles with molding extended from grade level up to and through communication service and transformer spaces.

3.3 GROUNDING UNDERGROUND DISTRIBUTION SYSTEM COMPONENTS

- A. Comply with IEEE C2 grounding requirements.
- B. Grounding Manholes and Handholes: Install a driven ground rod through manhole or handhole floor, close to wall, and set rod depth so 4 inches will extend above finished floor. If necessary, install ground rod before manhole is placed and provide No. 1/0 AWG bare, tinned-copper conductor from ground rod into manhole through a waterproof sleeve in manhole wall. Protect ground rods passing through concrete floor with a double wrapping of pressure-sensitive

Weedsport Addition to Maintenance Section and Roof Replacement, MP 304.2

insulating tape or heat-shrunk insulating sleeve from 2 inches above to 6 inches below concrete. Seal floor opening with waterproof, nonshrink grout.

- C. **Grounding Connections to Manhole Components:** Bond exposed-metal parts such as inserts, cable racks, pulling irons, ladders, and cable shields within each manhole or handhole, to ground rod or grounding conductor. Make connections with No. 4 AWG minimum, stranded, hard-drawn copper bonding conductor. Train conductors level or plumb around corners and fasten to manhole walls. Connect to cable armor and cable shields according to written instructions by manufacturer of splicing and termination kits.
- D. **Pad-Mounted Transformers and Switches:** Install two ground rods and ground ring around the pad. Ground pad-mounted equipment and noncurrent-carrying metal items associated with substations by connecting them to underground cable and grounding electrodes. Install tinned-copper conductor not less than No. 2 AWG for ground ring and for taps to equipment grounding terminals. Bury ground ring not less than 6 inches from the foundation.

3.4 EQUIPMENT GROUNDING

- A. Install insulated equipment grounding conductors with all feeders and branch circuits.
- B. Install insulated equipment grounding conductors with the following items, in addition to those required by NFPA 70:
 1. Feeders and branch circuits.
 2. Lighting circuits.
 3. Receptacle circuits.
 4. Single-phase motor and appliance branch circuits.
 5. Three-phase motor and appliance branch circuits.
 6. Flexible raceway runs.
 7. Armored and metal-clad cable runs.
 8. **Busway Supply Circuits:** Install insulated equipment grounding conductor from grounding bus in the switchgear, switchboard, or distribution panel to equipment grounding bar terminal on busway.
 9. **Computer and Rack-Mounted Electronic Equipment Circuits:** Install insulated equipment grounding conductor in branch-circuit runs from equipment-area power panels and power-distribution units.
 10. **X-Ray Equipment Circuits:** Install insulated equipment grounding conductor in circuits supplying x-ray equipment.
- C. **Air-Duct Equipment Circuits:** Install insulated equipment grounding conductor to duct-mounted electrical devices operating at 120 V and more, including air cleaners, heaters, dampers, humidifiers, and other duct electrical equipment. Bond conductor to each unit and to air duct and connected metallic piping.
- D. **Water Heater, Heat-Tracing, and Antifrost Heating Cables:** Install a separate insulated equipment grounding conductor to each electric water heater and heat-tracing cable. Bond conductor to heater units, piping, connected equipment, and components.
- E. **Isolated Grounding Receptacle Circuits:** Install an insulated equipment grounding conductor connected to the receptacle grounding terminal. Isolate conductor from raceway and from panelboard grounding terminals. Terminate at equipment grounding conductor terminal of the applicable derived system or service unless otherwise indicated.
- F. **Isolated Equipment Enclosure Circuits:** For designated equipment supplied by a branch circuit or feeder, isolate equipment enclosure from supply circuit raceway with a nonmetallic raceway

Weedsport Addition to Maintenance Section and Roof Replacement, MP 304.2

fitting listed for the purpose. Install fitting where raceway enters enclosure, and install a separate insulated equipment grounding conductor. Isolate conductor from raceway and from panelboard grounding terminals. Terminate at equipment grounding conductor terminal of the applicable derived system or service unless otherwise indicated.

- G. Signal and Communication Equipment: In addition to grounding and bonding required by NFPA 70, provide a separate grounding system complying with requirements in TIA/ATIS J-STD-607-A.
1. For telephone, alarm, voice and data, and other communication equipment, provide No. 4 AWG minimum insulated grounding conductor in raceway from grounding electrode system to each service location, terminal cabinet, wiring closet, and central equipment location.
 2. Service and Central Equipment Locations and Wiring Closets: Terminate grounding conductor on a 1/4-by-4-by-12-inch grounding bus.
 3. Terminal Cabinets: Terminate grounding conductor on cabinet grounding terminal.
- H. Metal and Wood Poles Supporting Outdoor Lighting Fixtures: Install grounding electrode and a separate insulated equipment grounding conductor in addition to grounding conductor installed with branch-circuit conductors.

3.5 INSTALLATION

- A. Grounding Conductors: Route along shortest and straightest paths possible unless otherwise indicated or required by Code. Avoid obstructing access or placing conductors where they may be subjected to strain, impact, or damage.
- B. Ground Bonding Common with Lightning Protection System: Comply with NFPA 780 and UL 96 when interconnecting with lightning protection system. Bond electrical power system ground directly to lightning protection system grounding conductor at closest point to electrical service grounding electrode. Use bonding conductor sized same as system grounding electrode conductor, and install in conduit.
- C. Ground Rods: Drive rods until tops are 2 inches below finished floor or final grade unless otherwise indicated.
1. Interconnect ground rods with grounding electrode conductor below grade and as otherwise indicated. Make connections without exposing steel or damaging coating if any.
 2. For grounding electrode system, install at least three rods spaced at least one-rod length from each other and located at least the same distance from other grounding electrodes, and connect to the service grounding electrode conductor.
- D. Test Wells: Ground rod driven through drilled hole in bottom of handhole. Handholes shall be at least 12 inches deep, with cover.
1. Test Wells: Install at least one test well for each service unless otherwise indicated. Install at the ground rod electrically closest to service entrance. Set top of test well flush with finished grade or floor.
- E. Bonding Straps and Jumpers: Install in locations accessible for inspection and maintenance except where routed through short lengths of conduit.
1. Bonding to Structure: Bond straps directly to basic structure, taking care not to penetrate any adjacent parts.
 2. Bonding to Equipment Mounted on Vibration Isolation Hangers and Supports: Install bonding so vibration is not transmitted to rigidly mounted equipment.

Weedsport Addition to Maintenance Section and Roof Replacement, MP 304.2

3. Use exothermic-welded connectors for outdoor locations; if a disconnect-type connection is required, use a bolted clamp.
- F. Grounding and Bonding for Piping:
1. Metal Water Service Pipe: Install insulated copper grounding conductors, in conduit, from building's main service equipment, or grounding bus, to main metal water service entrances to building. Connect grounding conductors to main metal water service pipes; use a bolted clamp connector or bolt a lug-type connector to a pipe flange by using one of the lug bolts of the flange. Where a dielectric main water fitting is installed, connect grounding conductor on street side of fitting. Bond metal grounding conductor conduit or sleeve to conductor at each end.
 2. Water Meter Piping: Use braided-type bonding jumpers to electrically bypass water meters. Connect to pipe with a bolted connector.
 3. Bond each aboveground portion of gas piping system downstream from equipment shutoff valve.
- G. Bonding Interior Metal Ducts: Bond metal air ducts to equipment grounding conductors of associated fans, blowers, electric heaters, and air cleaners. Install tinned bonding jumper to bond across flexible duct connections to achieve continuity.
- H. Grounding for Steel Building Structure: Install a driven ground rod at base of each corner column and at intermediate exterior columns at distances not more than 60 feet apart.
- I. Ground Ring: Install a grounding conductor, electrically connected to each building structure ground rod and to each steel column, extending around the perimeter of building.
1. Install tinned-copper conductor not less than No. 2/0 AWG for ground ring and for taps to building steel.
 2. Bury ground ring not less than 24 inches from building's foundation.
- J. Ufer Ground (Concrete-Encased Grounding Electrode): Fabricate according to NFPA 70; use a minimum of 20 feet of bare copper conductor not smaller than No. 4 AWG.
1. If concrete foundation is less than 20 feet long, coil excess conductor within base of foundation.
 2. Bond grounding conductor to reinforcing steel in at least four locations and to anchor bolts. Extend grounding conductor below grade and connect to building's grounding grid or to grounding electrode external to concrete.

3.6 LABELING

- A. Comply with requirements in Section 260553 "Identification for Electrical Systems" for instruction signs. The label or its text shall be green.
- B. Install labels at the telecommunications bonding conductor and grounding equalizer and at the grounding electrode conductor where exposed.
 1. Label Text: "If this connector or cable is loose or if it must be removed for any reason, notify the facility manager."

3.7 FIELD QUALITY CONTROL

- A. Testing Agency: Engage a qualified testing agency to perform tests and inspections.
- B. Manufacturer's Field Service: Engage a factory-authorized service representative to inspect, test, and adjust components, assemblies, and equipment installations, including connections.
- C. Perform tests and inspections.

Weedsport Addition to Maintenance Section and Roof Replacement, MP 304.2

1. Manufacturer's Field Service: Engage a factory-authorized service representative to inspect components, assemblies, and equipment installations, including connections, and to assist in testing.
- D. Tests and Inspections:
1. After installing grounding system but before permanent electrical circuits have been energized, test for compliance with requirements.
 2. Inspect physical and mechanical condition. Verify tightness of accessible, bolted, electrical connections with a calibrated torque wrench according to manufacturer's written instructions.
 3. Test completed grounding system at each location where a maximum ground-resistance level is specified, at service disconnect enclosure grounding terminal, at ground test wells, and at individual ground rods. Make tests at ground rods before any conductors are connected.
 - a. Measure ground resistance no fewer than two full days after last trace of precipitation and without soil being moistened by any means other than natural drainage or seepage and without chemical treatment or other artificial means of reducing natural ground resistance.
 - b. Perform tests by fall-of-potential method according to IEEE 81.
 4. Prepare dimensioned Drawings locating each test well, ground rod and ground-rod assembly, and other grounding electrodes. Identify each by letter in alphabetical order, and key to the record of tests and observations. Include the number of rods driven and their depth at each location, and include observations of weather and other phenomena that may affect test results. Describe measures taken to improve test results.
- E. Grounding system will be considered defective if it does not pass tests and inspections.
- F. Prepare test and inspection reports.
- G. Report measured ground resistances that exceed the following values:
1. Power and Lighting Equipment or System with Capacity of 500 kVA and Less: 10 ohms.
 2. Power and Lighting Equipment or System with Capacity of 500 to 1000 kVA: 5 ohms.
 3. Power and Lighting Equipment or System with Capacity More Than 1000 kVA: 3 ohms.
 4. Power Distribution Units or Panelboards Serving Electronic Equipment: 1 ohm(s).
 5. Substations and Pad-Mounted Equipment: 5 ohms.
 6. Manhole Grounds: 10 ohms.
- H. Excessive Ground Resistance: If resistance to ground exceeds specified values, notify Architect promptly and include recommendations to reduce ground resistance.

END OF SECTION 260526

THIS PAGE INTENTIONALLY LEFT BLANK

SECTION 260529 - HANGERS AND SUPPORTS FOR ELECTRICAL SYSTEMS

PART 1 - GENERAL

1.1 SUMMARY

- A. This Section includes the following:
 - 1. Hangers and supports for electrical equipment and systems.
 - 2. Construction requirements for concrete bases.

1.2 DEFINITIONS

- A. EMT: Electrical metallic tubing.
- B. IMC: Intermediate metal conduit.
- C. RMC: Rigid metal conduit.

1.3 PERFORMANCE REQUIREMENTS

- A. Design supports for multiple raceways capable of supporting combined weight of supported systems and its contents.
- B. Design equipment supports capable of supporting combined operating weight of supported equipment and connected systems and components.
- C. Rated Strength: Adequate in tension, shear, and pullout force to resist maximum loads calculated or imposed for this Project, with a minimum structural safety factor of five times the applied force.

1.4 QUALITY ASSURANCE

- A. Welding: Qualify procedures and personnel according to AWS D1.1/D1.1M, "Structural Welding Code - Steel."
- B. Comply with NFPA 70.

1.5 COORDINATION

- A. Coordinate size and location of concrete bases. Cast anchor-bolt inserts into bases. Concrete, reinforcement, and formwork requirements are specified in Division 3.
- B. Coordinate installation of roof curbs, equipment supports, and roof penetrations

PART 2 - PRODUCTS

2.1 SUPPORT, ANCHORAGE, AND ATTACHMENT COMPONENTS

- A. Steel Slotted Support Systems: Comply with MFMA-4, factory-fabricated components for field assembly.
 - 1. Manufacturers: Subject to compliance with requirements, provide products by one of the following:
 - a. Allied Tube & Conduit.
 - b. Cooper B-Line, Inc.; a division of Cooper Industries.
 - c. ERICO International Corporation.
 - d. Thomas & Betts Corporation.

Weedsport Addition to Maintenance Section and Roof Replacement, MP 304.2

- e. Unistrut; Tyco International, Ltd.
- f. Wesanco, Inc.
- 2. Metallic Coatings: Hot-dip galvanized after fabrication and applied according to MFMA-4.
- 3. Channel Dimensions: Selected for applicable load criteria.
- B. Raceway and Cable Supports: As described in NECA 1 and NECA 101.
- C. Conduit and Cable Support Devices: Steel hangers, clamps, and associated fittings, designed for types and sizes of raceway or cable to be supported.
- D. Support for Conductors in Vertical Conduit: Factory-fabricated assembly consisting of threaded body and insulating wedging plug or plugs for non-armored electrical conductors or cables in riser conduits. Plugs shall have number, size, and shape of conductor gripping pieces as required to suit individual conductors or cables supported. Body shall be malleable iron.
- E. Structural Steel for Fabricated Supports and Restraints: ASTM A 36/A 36M, steel plates, shapes, and bars; black and galvanized.
- F. Mounting, Anchoring, and Attachment Components: Items for fastening electrical items or their supports to building surfaces include the following:
 - 1. Powder-Actuated Fasteners: Threaded-steel stud, for use in hardened portland cement concrete, steel, or wood, with tension, shear, and pullout capacities appropriate for supported loads and building materials where used.
 - a. Manufacturers: Subject to compliance with requirements, provide products by one of the following:
 - 1) Hilti Inc.
 - 2) ITW Ramset/Red Head; a division of Illinois Tool Works, Inc.
 - 3) MKT Fastening, LLC.
 - 4) Simpson Strong-Tie Co., Inc.; Masterset Fastening Systems Unit.
 - 2. Mechanical-Expansion Anchors: Insert-wedge-type, zinc-coated steel, for use in hardened portland cement concrete with tension, shear, and pullout capacities appropriate for supported loads and building materials in which used.
 - a. Manufacturers: Subject to compliance with requirements, provide products by one of the following:
 - 1) Cooper B-Line, Inc.; a division of Cooper Industries.
 - 2) Hilti Inc.
 - 3) ITW Ramset/Red Head; a division of Illinois Tool Works, Inc.
 - 4) MKT Fastening, LLC.
 - 3. Concrete Inserts: Steel or malleable-iron, slotted support system units similar to MSS Type 18; complying with MFMA-4 or MSS SP-58.
 - 4. Clamps for Attachment to Steel Structural Elements: MSS SP-58, type suitable for attached structural element.
 - 5. Through Bolts: Structural type, hex head, and high strength. Comply with ASTM A 325.
 - 6. Toggle Bolts: All-steel springhead type.
 - 7. Hanger Rods: Threaded steel.

2.2 FABRICATED METAL EQUIPMENT SUPPORT ASSEMBLIES

- A. Description: Welded or bolted, structural-steel shapes, shop or field fabricated to fit dimensions of supported equipment.

PART 3 - EXECUTION

3.1 APPLICATION

- A. Comply with NECA 1 and NECA 101 for application of hangers and supports for electrical equipment and systems except if requirements in this Section are stricter.
- B. Maximum Support Spacing and Minimum Hanger Rod Size for Raceway: Space supports for EMT, IMC, and RMC as required by NFPA 70. Minimum rod size shall be 1/4 inch in diameter.
- C. Multiple Raceways or Cables: Install trapeze-type supports fabricated with steel slotted support system, sized so capacity can be increased by at least 25 percent in future without exceeding specified design load limits.
 - 1. Secure raceways and cables to these supports with two-bolt conduit clamps.

3.2 SUPPORT INSTALLATION

- A. Comply with NECA 1 and NECA 101 for installation requirements except as specified in this Article.
- B. Raceway Support Methods: In addition to methods described in NECA 1, EMT, IMC, and RMC may be supported by openings through structure members, as permitted in NFPA 70.
- C. Strength of Support Assemblies: Where not indicated, select sizes of components so strength will be adequate to carry present and future static loads within specified loading limits. Minimum static design load used for strength determination shall be weight of supported components plus 200 lb.
- D. Mounting and Anchorage of Surface-Mounted Equipment and Components: Anchor and fasten electrical items and their supports to building structural elements by the following methods unless otherwise indicated by code:
 - 1. To Wood: Fasten with lag screws or through bolts.
 - 2. To New Concrete: Bolt to concrete inserts.
 - 3. To Masonry: Approved toggle-type bolts on hollow masonry units and expansion anchor fasteners on solid masonry units.
 - 4. To Existing Concrete: Expansion anchor fasteners.
 - 5. Instead of expansion anchors, powder-actuated driven threaded studs provided with lock washers and nuts may be used in existing standard-weight concrete 4 inches thick or greater. Do not use for anchorage to lightweight-aggregate concrete or for slabs less than 4 inches thick.
 - 6. To Steel: Beam clamps (MSS Type 19, 21, 23, 25, or 27) complying with MSS SP-69.
 - 7. To Light Steel: Sheet metal screws.
 - 8. Items Mounted on Hollow Walls and Nonstructural Building Surfaces: Mount cabinets, panelboards, disconnect switches, control enclosures, pull and junction boxes, transformers, and other devices on slotted-channel racks attached to substrate.
- E. Drill holes for expansion anchors in concrete at locations and to depths that avoid reinforcing bars.

3.3 INSTALLATION OF FABRICATED METAL SUPPORTS

- A. Cut, fit, and place miscellaneous metal supports accurately in location, alignment, and elevation to support and anchor electrical materials and equipment.
- B. Field Welding: Comply with AWS D1.1/D1.1M.

Weedsport Addition to Maintenance Section and Roof Replacement, MP 304.2

3.4 PAINTING

- A. Touchup: Clean field welds and abraded areas of shop paint. Paint exposed areas immediately after erecting hangers and supports. Use same materials as used for shop painting. Comply with SSPC-PA 1 requirements for touching up field-painted surfaces.
 - 1. Apply paint by brush or spray to provide minimum dry film thickness of 2.0 mils.
- B. Touchup: Comply with requirements in Division 9 painting Sections for cleaning and touchup painting of field welds, bolted connections, and abraded areas of shop paint on miscellaneous metal.
- C. Galvanized Surfaces: Clean welds, bolted connections, and abraded areas and apply galvanizing-repair paint to comply with ASTM A 780.

END OF SECTION 260529

SECTION 260533 - RACEWAYS AND BOXES

PART 1 - GENERAL

1.1 SUMMARY

- A. This Section includes raceways, fittings, connectors and couplings, boxes, enclosures, and cabinets for electrical wiring.
1. Raceways include the following:
 - a. RMC.
 - b. IMC.
 - c. PVC externally coated, rigid steel conduits.
 - d. PVC externally coated, IMC.
 - e. EMT.
 - f. FMC.
 - g. LFMC.
 - h. LFNC.
 - i. RNC.
 - j. ENT.
 - k. Wireways.
 - l. Surface raceways.
 - m. Type MC cable
 2. Boxes, enclosures, and cabinets include the following:
 - a. Device boxes.
 - b. Floor boxes.
 - c. Outlet boxes.
 - d. Pull and junction boxes.
 - e. Cabinets and hinged-cover enclosures.

1.2 DEFINITIONS

- A. EMT: Electrical metallic tubing.
- B. ENT: Electrical nonmetallic tubing.
- C. FMC: Flexible metal conduit.
- D. IMC: Intermediate metal conduit.
- E. LFMC: Liquidtight flexible metal conduit.
- F. LFNC: Liquidtight flexible nonmetallic conduit.
- G. RMC: Rigid metal conduit.
- H. RNC: Rigid nonmetallic conduit.

1.3 SUBMITTALS

- A. Product Data: For surface raceways, wireways and fittings, hinged-cover enclosures, and cabinets.
- B. Shop Drawings: Include layout drawings showing components and wiring for nonstandard boxes, enclosures, and cabinets.

Weedsport Addition to Maintenance Section and Roof Replacement, MP 304.2

1.4 QUALITY ASSURANCE

- A. Listing and Labeling: Provide raceways and boxes specified in this Section that are listed and labeled.
 - 1. The Terms "Listed" and "Labeled": As defined in NFPA 70, Article 100.
 - 2. Listing and Labeling Agency Qualifications: A "Nationally Recognized Testing Laboratory" as defined in OSHA Regulation 1910.7.
- B. Comply with NECA's "Standard of Installation."
- C. Comply with NFPA 70.

1.5 COORDINATION

- A. Coordinate layout and installation of raceways and boxes with other construction elements to ensure adequate headroom, working clearance, and access.

PART 2 - PRODUCTS

2.1 MANUFACTURERS

- A. Manufacturers: Subject to compliance with requirements, provide products by one of the following:
 - 1. Metal Conduit and Tubing:
 - a. Alflex Corp.
 - b. Anamet, Inc.; Anaconda Metal Hose.
 - c. Carol Cable Co., Inc.
 - d. Cole-Flex Corp.
 - e. Electri-Flex Co.
 - f. Flexcon, Inc.; Coleman Cable Systems, Inc.
 - g. Grinnell Co.; Allied Tube and Conduit Div.
 - 2. Nonmetallic Conduit and Tubing:
 - a. Anamet, Inc.; Anaconda Metal Hose.
 - b. Arnco Corp.
 - c. Cantex Industries; Harsco Corp.
 - d. Certainteed Corp.; Pipe & Plastics Group.
 - e. Cole-Flex Corp.
 - f. Condux International; Electrical Products.
 - g. Electri-Flex Co.
 - h. Hubbell, Inc.; Raco, Inc.
 - i. Lamson & Sessions; Carlon Electrical Products.
 - j. R&G Sloan Manufacturing Co., Inc.
 - k. Thomas & Betts Corp.
 - 3. Conduit Bodies and Fittings:
 - a. American Electric; Construction Materials Group.
 - b. Crouse-Hinds; Div. of Cooper Industries.
 - c. Emerson Electric Co.; Appleton Electric Co.
 - d. Hubbell, Inc.; Killark Electric Manufacturing Co.
 - e. Lamson & Sessions; Carlon Electrical Products.
 - f. O-Z/Gedney; Unit of General Signal.
 - 4. Metal Wireways:
 - a. Hoffman Engineering Co.
 - b. Keystone/Rees, Inc.

Weedsport Addition to Maintenance Section and Roof Replacement, MP 304.2

- c. Square D Co.
- 5. Nonmetallic Wireways:
 - a. Hoffman Engineering Co.
 - b. Lamson & Sessions; Carlon Electrical Products.
- 6. Surface Metal Raceways:
 - a. American Electric; Construction Materials Group.
 - b. Butler Manufacturing Co.; Walker Division.
 - c. Wiremold Co. (The); Electrical Sales Division.
- 7. Surface Nonmetallic Raceways:
 - a. Butler Manufacturing Co.; Walker Division.
 - b. Hubbell, Inc.; Wiring Device Division.
 - c. Lamson & Sessions; Carlon Electrical Products.
 - d. Panduit Corp.
 - e. United Telecom; Premier Telecom Products, Inc.
 - f. Wiremold Co. (The); Electrical Sales Division.
- 8. Boxes, Enclosures, and Cabinets:
 - a. American Electric; FL Industries.
 - b. Butler Manufacturing Co.; Walker Division.
 - c. Crouse-Hinds; Div. of Cooper Industries.
 - d. Electric Panelboard Co., Inc.
 - e. Hoffman Engineering Co.; Federal-Hoffman, Inc.
 - f. Hubbell Inc.; Killark Electric Manufacturing Co.
 - g. Hubbell Inc.; Racor, Inc.
 - h. Lamson & Sessions; Carlon Electrical Products.
 - i. O-Z/Gedney; Unit of General Signal.
 - j. Parker Electrical Manufacturing Co.
 - k. Robroy Industries, Inc.; Electrical Division.
 - l. Thomas & Betts Corp.

2.2 METAL CONDUIT AND TUBING

- A. Rigid Steel Conduit: ANSI C80.1.
- B. Rigid Aluminum Conduit: ANSI C80.5.
- C. IMC: ANSI C80.6.
- D. Plastic-Coated Steel Conduit and Fittings: NEMA RN 1.
- E. Plastic-Coated IMC and Fittings: NEMA RN 1.
- F. EMT and Fittings: ANSI C80.3.
 - 1. Fittings: Set-screw or compression type.
- G. FMC: Aluminum.
- H. FMC: Zinc-coated steel.
- I. LFMC: Flexible steel conduit with PVC jacket.
- J. Fittings: NEMA FB 1; compatible with conduit/tubing materials.

2.3 NONMETALLIC CONDUIT AND TUBING

- A. ENT: NEMA TC 13.
- B. RNC: NEMA TC 2, Schedule 40 or 80 PVC.

Weedsport Addition to Maintenance Section and Roof Replacement, MP 304.2

- C. ENT and RNC Fittings: NEMA TC 3; match to conduit or conduit/tubing type and material.
- D. LFNC: UL 1660.

2.4 METAL WIREWAYS

- A. Material: Sheet metal sized and shaped as indicated.
- B. Fittings and Accessories: Include couplings, offsets, elbows, expansion joints, adapters, hold-down straps, end caps, and other fittings to match and mate with wireways as required for complete system.
- C. Select features, unless otherwise indicated, as required to complete wiring system and to comply with NFPA 70.
- D. Wireway Covers: As indicated
- E. Wireway Covers: Hinged type.
- F. Wireway Covers: Screw-cover type.
- G. Wireway Covers: Flanged-and-gasketed type.
- H. Finish: Manufacturer's standard enamel finish.

2.5 NONMETALLIC WIREWAYS

- A. Description: Fiberglass polyester, extruded and fabricated to size and shape indicated, with no holes or knockouts. Cover is gasketed with oil-resistant gasket material and fastened with captivated screws treated for corrosion resistance. Connections are flanged, with stainless-steel screws and oil-resistant gaskets.
- B. Description: PVC plastic, extruded and fabricated to size and shape indicated, with snap-on cover and mechanically coupled connections using plastic fasteners.
- C. Fittings and Accessories: Include couplings, offsets, elbows, expansion joints, adapters, hold-down straps, end caps, and other fittings to match and mate with wireways as required for complete system.
- D. Select features, unless otherwise indicated, as required to complete wiring system and to comply with NFPA 70.

2.6 NON-METALLIC SURFACE RACEWAY

- A. Wiremold 5400 two-piece surface non-metallic raceway or approved equivalent. Electrical Contractor is responsible for providing and installing all surface mounted raceway as indicated on associated electrical drawings. Raceway system shall include but not be limited to items listed below. Contractor is responsible for providing a complete operational surface raceway system where indicated on associated electrical drawings.
 1. Provide divider plate for separation of communications and power wiring.
 2. Size: 1-11/16" x 5-1/4"W
 3. Provide two section Base No. 5400TB and cover No. 5400C as required.
 4. Install where indicated on the associated electrical drawings with devices as noted.
 5. Install where ceilings are inaccessible.
 6. Raceway color shall be ivory. Color of receptacles and connectors shall match raceway.

Weedsport Addition to Maintenance Section and Roof Replacement, MP 304.2

7. Provide all necessary parts including, but not limited to, the following:
 - a. Wire Clip No. 5400TWC
 - b. Cover Clip No. 5406A
 - c. Flat Elbow No. 5411
 - d. End Cap No. 5410
 - e. Internal Elbow No. 5417
 - f. External Elbow No. 5418
 - g. Device Bracket and Faceplate No. 5407
 - h. Duplex Faceplate No. 5507D

2.7 CONNECTORS AND COUPLINGS

- A. Locknuts: Appleton Electric Co. BL-50 Series, Gould Inc. Efcor 151 Series, Midwest Electric Mfg. Corp. 10 Series, OZ/Gedney Co. 1-50S Series, Raco Inc. 1002 Series, or Thomas & Betts Corp. 141 Series.
- B. Grounding Wedge: Thomas & Betts Corp. 3650 Series
- C. Couplings (For Rigid and IMC Conduit): Standard threaded couplings as furnished by conduit manufacturer.
- D. Three Piece Conduit Coupling (For Rigid and IMC Conduit): Gould Inc. Efcor 165 Series, Midwest Electric Mfg. Corp. 190 Series, OZ/Gedney Co. 4-50 Series, Raco Inc. 1502 Series, or Thomas & Betts Corp. 675 Series
- E. Set Screw Type: Appleton Electric Co., Gould Inc. Efcor, Midwest Electric Mfg. Corp., Raco Inc., Tomic Electric, or Thomas & Betts Corp.
- F. Flexible Steel Conduit Connectors: Midwest Electric Mfg. Corp. 1708, 1736 Series, OZ/Gedney Co. C-8T, 24-34T, ACV-50T Series, or Thomas & Betts Corp. Nylon insulated Tite-Bite Series.
- G. Sealtite Connectors (For Liquidtight Metal Conduit): Appleton Electric Co. STB Series, Crouse-Hinds Co. LTB Series, Gould Inc Efcor 11-50B Series, Ideal Industries Inc. 75-521 Series, Midwest Electric Mfg. Corp. LTB Series, OZ/Gedney Co. 4Q-50T Series, Raco Inc. 3512 Series, or Thomas & Betts Corp. 5332 Series.

2.8 FLOOR BOXES

- A. Floor Boxes: metallic or nonmetallic, shallow, rectangular box.
- B. Four compartment with wiring dividers for power and communication wiring.
- C. Provide with mud cap for protection during concrete pour of floor slab.
- D. Provide with internal duplex receptacle brackets and communication brackets.
- E. Provide with brushed metal cover - finish to be determined by architect at submittal time. Cover to have capability to remain closed with cables exiting box.
- F. Legrand RFB2 Series.

2.9 OUTLET AND DEVICE BOXES

- A. Sheet Metal Boxes: NEMA OS 1.

Weedsport Addition to Maintenance Section and Roof Replacement, MP 304.2

- B. Cast-Metal Boxes: NEMA FB 1, Type FD, cast box with gasketed cover.

2.10 PULL AND JUNCTION BOXES

- A. Small Sheet Metal Boxes: NEMA OS 1.
- B. Cast-Metal Boxes: NEMA FB 1, cast aluminum with gasketed cover.

2.11 ENCLOSURES AND CABINETS

- A. Hinged-Cover Enclosures: NEMA 250, Type 1, with continuous hinge cover and flush latch.
 1. Metal Enclosures: Steel, finished inside and out with manufacturer's standard enamel.
 2. Nonmetallic Enclosures: Plastic, finished inside with radio-frequency-resistant paint.
- B. Cabinets: NEMA 250, Type 1, galvanized steel box with removable interior panel and removable front, finished inside and out with manufacturer's standard enamel. Hinged door in front cover with flush latch and concealed hinge. Key latch to match panelboards. Include metal barriers to separate wiring of different systems and voltage, and include accessory feet where required for freestanding equipment.

PART 3 - EXECUTION**3.1 EXAMINATION**

- A. Examine surfaces to receive raceways, boxes, enclosures, and cabinets for compliance with installation tolerances and other conditions affecting performance of raceway installation. Do not proceed with installation until unsatisfactory conditions have been corrected.

3.2 WIRING METHODS

- A. Outdoors: Use the following wiring methods:
 1. Exposed: Rigid steel.
 2. Concealed: Rigid steel.
 3. Underground, Single Run: RNC.
 4. Underground, Grouped: RNC.
 5. Connection to Vibrating Equipment (Including Transformers and Hydraulic, Pneumatic, Electric Solenoid, or Motor-Driven Equipment): LFMC.
 6. Boxes and Enclosures: NEMA 250, Type 3R or Type 4.
- B. Indoors: Use the following wiring methods:
 1. Exposed: EMT. Non-metallic and metallic surface raceways as shown on associated electrical drawings.
 2. Concealed: EMT
 3. Concealed in slab on grade: RNC (transition to 90 degree rigid steel elbow prior to exiting floor slab on grade)
 4. Connection to Vibrating Equipment (Including Transformers and Hydraulic, Pneumatic, Electric Solenoid, or Motor-Driven Equipment): FMC; except in wet or damp locations, use LFMC.
 5. Damp or Wet Locations: Rigid steel conduit.
 6. Boxes and Enclosures: NEMA 250, Type 1, except as follows:
 - a. Damp or Wet Locations: NEMA 250, Type 4, stainless steel.

Weedsport Addition to Maintenance Section and Roof Replacement, MP 304.2

3.3 INSTALLATION

- A. Install raceways, boxes, enclosures, and cabinets as indicated, according to manufacturer's written instructions.
- B. Minimum Raceway Size: 3/4-inch trade size. Unless otherwise noted
- C. Conceal conduit and EMT, unless otherwise indicated, within finished walls, ceilings, and floors.
- D. Keep raceways at least 6 inches away from parallel runs of flues and steam or hot-water pipes. Install horizontal raceway runs above water and steam piping.
- E. Install raceways level and square and at proper elevations. Provide adequate headroom.
- F. Complete raceway installation before starting conductor installation.
- G. Support raceways as specified in Division 16 Section "Basic Electrical Materials and Methods."
- H. Use temporary closures to prevent foreign matter from entering raceways.
- I. Protect stub-ups from damage where conduits rise through floor slabs. Arrange so curved portion of bends is not visible above the finished slab.
- J. Make bends and offsets so ID is not reduced. Keep legs of bends in the same plane and straight legs of offsets parallel, unless otherwise indicated.
- K. Use raceway fittings compatible with raceways and suitable for use and location. For intermediate steel conduit, use threaded rigid steel conduit fittings, unless otherwise indicated.
- L. Run concealed raceways, with a minimum of bends, in the shortest practical distance considering the type of building construction and obstructions, unless otherwise indicated.
- M. Raceways Embedded in Slabs: Install in middle third of slab thickness where practical, and leave at least 1-inch concrete cover.
 - 1. Secure raceways to reinforcing rods to prevent sagging or shifting during concrete placement.
 - 2. Space raceways laterally to prevent voids in concrete.
 - 3. Run conduit larger than 1-inch trade size parallel to or at right angles to main reinforcement. Where at right angles to reinforcement, place conduit close to slab support.
 - 4. Transition from nonmetallic tubing to Schedule rigid steel conduit before rising above floor.
- N. Install exposed raceways parallel to or at right angles to nearby surfaces or structural members, and follow the surface contours as much as practical.
 - 1. Run parallel or banked raceways together, on common supports where practical.
 - 2. Make bends in parallel or banked runs from same centerline to make bends parallel. Use factory elbows only where elbows can be installed parallel; otherwise, provide field bends for parallel raceways.
- O. Join raceways with fittings designed and approved for the purpose and make joints tight.
 - 1. Make raceway terminations tight. Use bonding bushings or wedges at connections subject to vibration. Use bonding jumpers where joints cannot be made tight.
 - 2. Use insulating bushings to protect conductors.
- P. Terminations: Where raceways are terminated with locknuts and bushings, align raceways to enter squarely and install locknuts with dished part against the box. Where terminations are not secure with 1 locknut, use 2 locknuts: 1 inside and 1 outside the box.

Weedsport Addition to Maintenance Section and Roof Replacement, MP 304.2

- Q. Where raceways are terminated with threaded hubs, screw raceways or fittings tightly into the hub so the end bears against the wire protection shoulder. Where chase nipples are used, align raceways so the coupling is square to the box and tighten the chase nipple so no threads are exposed.
- R. Install pull wires in empty raceways. Use No. 14 AWG zinc-coated steel or monofilament plastic line with not less than 200-lb tensile strength. Leave at least 12 inches of slack at each end of the pull wire.
- S. Telephone and Signal System Raceways, 2-Inch Trade Size and Smaller: In addition to the above requirements, install raceways in maximum lengths of 150 feet and with a maximum of two 90-degree bends or equivalent. Separate lengths with pull or junction boxes where necessary to comply with these requirements.
- T. Install raceway sealing fittings according to manufacturer's written instructions. Locate fittings at suitable, approved, and accessible locations and fill them with UL-listed sealing compound. For concealed raceways, install each fitting in a flush steel box with a blank cover plate having a finish similar to that of adjacent plates or surfaces. Install raceway sealing fittings at the following points:
1. Where conduits pass from warm to cold locations, such as the boundaries of refrigerated spaces.
 2. Where otherwise required by NFPA 70.
- U. Stub-up Connections: Extend conduits through concrete floor for connection to freestanding equipment. Install with an adjustable top or coupling threaded inside for plugs set flush with the finished floor. Extend conductors to equipment with rigid steel conduit; FMC may be used 6 inches above the floor. Install screwdriver-operated, threaded flush plugs flush with floor for future equipment connections.
- V. Flexible Connections: Use maximum of 6 feet of flexible conduit for recessed and semirecessed lighting fixtures; for equipment subject to vibration, noise transmission, or movement; and for all motors. Use liquid tight flexible conduit in wet or damp locations. Install separate ground conductor across flexible connections.
- W. Install nonferrous conduit or tubing for circuits operating above 60 Hz. Where aluminum raceways are installed for such circuits and pass through concrete, install in a nonmetallic sleeve.
- X. Do not install aluminum conduits embedded in or in contact with concrete.
- Y. PVC Externally Coated, Rigid Steel Conduits: Use only fittings approved for use with that material. Patch all nicks and scrapes in PVC coating after installing conduits.
- Z. Surface Raceways: Install a separate, green, ground conductor in raceways from junction box supplying the raceways to receptacle or fixture ground terminals.
1. Select each surface raceway outlet box, to which a lighting fixture is attached, of sufficient diameter to provide a seat for the fixture canopy.
 2. Where a surface raceway is used to supply a fluorescent lighting fixture having central-stem suspension with a backplate and a canopy (with or without extension ring), no separate outlet box is required.
 3. Provide surface metal raceway outlet box, and the backplate and canopy, at the feed-in location of each fluorescent lighting fixture having end-stem suspension.
 4. Where a surface metal raceway extension is made from an existing outlet box on which a lighting fixture is installed, no additional surface-mounted outlet box is required. Provide a backplate slightly smaller than the fixture canopy.
- AA. Set floor boxes level and adjust to finished floor surface.

Weedsport Addition to Maintenance Section and Roof Replacement, MP 304.2

BB. Install hinged-cover enclosures and cabinets plumb. Support at each corner.

3.4 PROTECTION

- A. Provide final protection and maintain conditions, in a manner acceptable to manufacturer and Installer that ensure coatings, finishes, and cabinets are without damage or deterioration at the time of Substantial Completion.
1. Repair damage to galvanized finishes with zinc-rich paint recommended by manufacturer.
 2. Repair damage to PVC or paint finishes with matching touchup coating recommended by manufacturer.

3.5 CLEANING

- A. On completion of installation, including outlet fittings and devices, inspect exposed finish. Remove burrs, dirt, and construction debris and repair damaged finish, including chips, scratches, and abrasions.

END OF SECTION 260533

THIS PAGE INTENTIONALLY LEFT BLANK

SECTION 260544 - SLEEVES & SLEEVE SEALS FOR
ELECTRICAL RACEWAYS & CABLING

PART 1 - GENERAL

1.1 SUMMARY

- A. Section Includes:
1. Sleeves for raceway and cable penetration of non-fire-rated construction walls and floors.
 2. Sleeve-seal systems.
 3. Sleeve-seal fittings.
 4. Grout.
 5. Silicone sealants.

PART 2 - PRODUCTS

2.1 SLEEVES

- A. Wall Sleeves:
1. Steel Pipe Sleeves: ASTM A 53/A 53M, Type E, Grade B, Schedule 40, zinc coated, plain ends.
 2. Cast-Iron Pipe Sleeves: Cast or fabricated "wall pipe," equivalent to ductile-iron pressure pipe, with plain ends and integral waterstop unless otherwise indicated.
- B. Sleeves for Conduits Penetrating Non-Fire-Rated Gypsum Board Assemblies: Galvanized-steel sheet; 0.0239-inch minimum thickness; round tube closed with welded longitudinal joint, with tabs for screw-fastening the sleeve to the board.
- C. PVC-Pipe Sleeves: ASTM D 1785, Schedule 40.
- D. Molded-PVC Sleeves: With nailing flange for attaching to wooden forms.
- E. Molded-PE or -PP Sleeves: Removable, tapered-cup shaped, and smooth outer surface with nailing flange for attaching to wooden forms.
- F. Sleeves for Rectangular Openings:
1. Material: Galvanized sheet steel.
 2. Minimum Metal Thickness:
 - a. For sleeve cross-section rectangle perimeter less than 50 inches and with no side larger than 16 inches, thickness shall be 0.052 inch.
 - b. For sleeve cross-section rectangle perimeter 50 inches or more and one or more sides larger than 16 inches, thickness shall be 0.138 inch.

2.2 SLEEVE-SEAL SYSTEMS

- A. Description: Modular sealing device, designed for field assembly, to fill annular space between sleeve and raceway or cable.
1. Manufacturers: Subject to compliance with requirements, available manufacturers offering products that may be incorporated into the Work include, but are not limited to, the following:
 - a. Advance Products & Systems, Inc.
 - b. CALPICO, Inc.
 - c. Metraflex Company (The).

Weedsport Addition to Maintenance Section and Roof Replacement, MP 304.2

- d. Pipeline Seal and Insulator, Inc.
- e. Proco Products, Inc.
- 2. Sealing Elements: EPDM rubber interlocking links shaped to fit surface of pipe. Include type and number required for pipe material and size of pipe.
- 3. Pressure Plates: carbon steel or stainless steel.
- 4. Connecting Bolts and Nuts: carbon steel, with corrosion-resistant coating or stainless steel of length required to secure pressure plates to sealing elements.

2.3 SLEEVE-SEAL FITTINGS

- A. Description: Manufactured plastic, sleeve-type, waterstop assembly made for embedding in concrete slab or wall. Unit shall have plastic or rubber waterstop collar with center opening to match piping OD.

2.4 GROUT

- A. Description: Nonshrink; recommended for interior and exterior sealing openings in non-fire-rated walls or floors.
- B. Standard: ASTM C 1107/C 1107M, Grade B, post-hardening and volume-adjusting, dry, hydraulic-cement grout.
- C. Design Mix: 5000-psi 28-day compressive strength.
- D. Packaging: Premixed and factory packaged.

2.5 SILICONE SEALANTS

- A. Silicone Sealants: Single-component, silicone-based, neutral-curing elastomeric sealants of grade indicated below.
 - 1. Grade: Pourable (self-leveling) formulation for openings in floors and other horizontal surfaces that are not fire rated.
 - 2. Sealant shall comply with the testing and product requirements of the California Department of Health Services' "Standard Practice for the Testing of Volatile Organic Emissions from Various Sources Using Small-Scale Environmental Chambers."
- B. Silicone Foams: Multicomponent, silicone-based liquid elastomers that, when mixed, expand and cure in place to produce a flexible, nonshrinking foam.

PART 3 - EXECUTION**3.1 SLEEVE INSTALLATION FOR NON-FIRE-RATED ELECTRICAL PENETRATIONS**

- A. Comply with NECA 1.
- B. Comply with NEMA VE 2 for cable tray and cable penetrations.
- C. Sleeves for Conduits Penetrating Above-Grade Non-Fire-Rated Concrete and Masonry-Unit Floors and Walls:
 - 1. Interior Penetrations of Non-Fire-Rated Walls and Floors:
 - a. Seal annular space between sleeve and raceway or cable, using joint sealant appropriate for size, depth, and location of joint. Comply with requirements in Section 079200 "Joint Sealants."

Weedsport Addition to Maintenance Section and Roof Replacement, MP 304.2

- b. Seal space outside of sleeves with mortar or grout. Pack sealing material solidly between sleeve and wall so no voids remain. Tool exposed surfaces smooth; protect material while curing.
 - 2. Use pipe sleeves unless penetration arrangement requires rectangular sleeved opening.
 - 3. Size pipe sleeves to provide 1/4-inch annular clear space between sleeve and raceway or cable unless sleeve seal is to be installed.
 - 4. Install sleeves for wall penetrations unless core-drilled holes or formed openings are used. Install sleeves during erection of walls. Cut sleeves to length for mounting flush with both surfaces of walls. Deburr after cutting.
 - 5. Install sleeves for floor penetrations. Extend sleeves installed in floors 2 inches above finished floor level. Install sleeves during erection of floors.
- D. Sleeves for Conduits Penetrating Non-Fire-Rated Gypsum Board Assemblies:
- 1. Use circular metal sleeves unless penetration arrangement requires rectangular sleeved opening.
 - 2. Seal space outside of sleeves with approved joint compound for gypsum board assemblies.
- E. Roof-Penetration Sleeves: Seal penetration of individual raceways and cables with flexible boot-type flashing units applied in coordination with roofing work.
- F. Aboveground, Exterior-Wall Penetrations: Seal penetrations using steel or cast-iron pipe sleeves and mechanical sleeve seals. Select sleeve size to allow for 1-inch annular clear space between pipe and sleeve for installing mechanical sleeve seals.
- G. Underground, Exterior-Wall and Floor Penetrations: Install cast-iron pipe sleeves. Size sleeves to allow for 1-inch annular clear space between raceway or cable and sleeve for installing sleeve-seal system.

3.2 SLEEVE-SEAL-SYSTEM INSTALLATION

- A. Install sleeve-seal systems in sleeves in exterior concrete walls and slabs-on-grade at raceway entries into building.
- B. Install type and number of sealing elements recommended by manufacturer for raceway or cable material and size. Position raceway or cable in center of sleeve. Assemble mechanical sleeve seals and install in annular space between raceway or cable and sleeve. Tighten bolts against pressure plates that cause sealing elements to expand and make watertight seal.

3.3 SLEEVE-SEAL-FITTING INSTALLATION

- A. Install sleeve-seal fittings in new walls and slabs as they are constructed.
- B. Assemble fitting components of length to be flush with both surfaces of concrete slabs and walls. Position waterstop flange to be centered in concrete slab or wall.
- C. Secure nailing flanges to concrete forms.
- D. Using grout, seal the space around outside of sleeve-seal fittings.

END OF SECTION 260544

THIS PAGE INTENTIONALLY LEFT BLANK

SECTION 260553 - ELECTRICAL IDENTIFICATION

PART 1 - GENERAL

1.1 RELATED DOCUMENTS

- A. Drawings and general provisions of the Contract, including General and Supplementary Conditions and Division 1 Specification Sections, apply to this Section.

1.2 SUMMARY

- A. This Section includes electrical identification materials and devices required to comply with ANSI C2, NFPA 70, OSHA standards, and authorities having jurisdiction.

1.3 SUBMITTALS

- A. Product Data: For each electrical identification product indicated.
- B. Schedule of Nomenclature: An index of electrical equipment and system components used in identification signs and labels.
- C. Samples: For each type of label and sign to illustrate color, lettering style, and graphic features of identification products.

1.4 QUALITY ASSURANCE

- A. Comply with ANSI C2.
- B. Comply with NFPA 70.
- C. Comply with ANSI A13.1 and NFPA 70 for color-coding.

PART 2 - PRODUCTS

2.1 RACEWAY AND CABLE LABELS

- A. Comply with ANSI A13.1, Table 3, for minimum size of letters for legend and for minimum length of color field for each raceway and cable size.
 - 1. Color: Black letters on orange field.
 - 2. Legend: Indicates voltage and service.
- B. Adhesive Labels: Preprinted, flexible, self-adhesive vinyl with legend overlaminated with a clear, weather- and chemical-resistant coating.
- C. Pretensioned, Wraparound Plastic Sleeves: Flexible, preprinted, color-coded, acrylic band sized to suit the diameter of the line it identifies and arranged to stay in place by pretensioned gripping action when placed in position.
- D. Colored Adhesive Tape: Self-adhesive vinyl tape not less than 3 mils thick by 1 to 2 inches wide.
- E. Underground-Line Warning Tape: Permanent, bright-colored, continuous-printed, vinyl tape.
 - 1. Not less than 6 inches wide by 4 mils thick.
 - 2. Compounded for permanent direct-burial service.
 - 3. Embedded continuous metallic strip or core.
 - 4. Printed legend indicating type of underground line.

Weedsport Addition to Maintenance Section and Roof Replacement, MP 304.2

- F. Tape Markers: Vinyl or vinyl-cloth, self-adhesive, wraparound type with preprinted numbers and letters.
- G. Aluminum, Wraparound Marker Bands: Bands cut from 0.014-inch- thick aluminum sheet, with stamped or embossed legend, and fitted with slots or ears for permanently securing around wire or cable jacket or around groups of conductors.
- H. Plasticized Card-Stock Tags: Vinyl cloth with preprinted and field-printed legends. Orange background, unless otherwise indicated, with eyelet for fastener.
- I. Aluminum-Faced, Card-Stock Tags: Weather-resistant, 18-point minimum card stock faced on both sides with embossable aluminum sheet, 0.002 inch thick, laminated with moisture-resistant acrylic adhesive, punched for fasteners, and preprinted with legends to suit each application.
- J. Brass or Aluminum Tags: 2 by 2 by 0.05-inch metal tags with stamped legend, punched for fastener.

2.2 NAMEPLATES AND SIGNS

- A. Safety Signs: Comply with 29 CFR, Chapter XVII, Part 1910.145.
- B. Engraved Plastic Nameplates and Signs: Engraving stock, melamine plastic laminate, minimum 1/16 inch thick for signs up to 20 sq. in. and 1/8 inch thick for larger sizes.
 - 1. Engraved legend with black letters on white face.
 - 2. Punched or drilled for mechanical fasteners.
- C. Baked-Enamel Signs for Interior Use: Preprinted aluminum signs, punched or drilled for fasteners, with colors, legend, and size required for the application. 1/4-inch grommets in corners for mounting.
- D. Exterior, Metal-Backed, Butyrate Signs: Weather-resistant, nonfading, preprinted, cellulose-acetate butyrate signs with 0.0396-inch galvanized-steel backing; and with colors, legend, and size required for the application. 1/4-inch grommets in corners for mounting.
- E. Fasteners for Nameplates and Signs: Self-tapping, stainless-steel screws or No. 10/32, stainless-steel machine screws with nuts and flat and lock washers.

2.3 MISCELLANEOUS IDENTIFICATION PRODUCTS

- A. Cable Ties: Fungus-inert, self-extinguishing, one-piece, self-locking, Type 6/6 nylon cable ties.
 - 1. Minimum Width: 3/16 inch.
 - 2. Tensile Strength: 50 lb minimum.
 - 3. Temperature Range: Minus 40 to plus 185 deg F.
 - 4. Color: According to color-coding.
- B. Paint: Formulated for the type of surface and intended use.
 - 1. Primer for Galvanized Metal: Single-component acrylic vehicle formulated for galvanized surfaces.
 - 2. Primer for Concrete Masonry Units: Heavy-duty-resin block filler.
 - 3. Primer for Concrete: Clear, alkali-resistant, binder-type sealer.
 - 4. Enamel: Silicone-alkyd or alkyd urethane as recommended by primer manufacturer.

PART 3 - EXECUTION

3.1 INSTALLATION

- A. Identification Materials and Devices: Install at locations for most convenient viewing without interference with operation and maintenance of equipment.
- B. Lettering, Colors, and Graphics: Coordinate names, abbreviations, colors, and other designations with corresponding designations in the Contract Documents or with those required by codes and standards. Use consistent designations throughout Project.
- C. Sequence of Work: If identification is applied to surfaces that require finish, install identification after completing finish work.
- D. Self-Adhesive Identification Products: Clean surfaces before applying.
- E. Circuits with More Than 600 V: Identify raceway and cable with "DANGER--HIGH VOLTAGE" in black letters 2 inches high, stenciled with paint at 10-foot intervals over a continuous, painted orange background. Identify the following:
 - 1. Entire floor area directly above conduits running beneath and within 12 inches of a basement or ground floor that is in contact with earth or is framed above unexcavated space.
 - 2. Wall surfaces directly external to conduits concealed within wall.
 - 3. All accessible surfaces of concrete envelope around conduits in vertical shafts, exposed in the building, or concealed above suspended ceilings.
 - 4. Entire surface of exposed conduits.
- F. Install painted identification according to manufacturer's written instructions and as follows:
 - 1. Clean surfaces of dust, loose material, and oily films before painting.
 - 2. Prime surfaces using type of primer specified for surface.
 - 3. Apply one intermediate and one finish coat of enamel.
- G. Color Banding Raceways and Exposed Cables: Band exposed and accessible raceways of the systems listed below:
 - 1. Bands: Pretensioned, wraparound plastic sleeves; colored adhesive tape; or a combination of both. Make each color band 2 inches wide, completely encircling conduit, and place adjacent bands of two-color markings in contact, side by side.
 - 2. Band Locations: At changes in direction, at penetrations of walls and floors, at 50-foot maximum intervals in straight runs, and at 25-foot maximum intervals in congested areas.
 - 3. Apply the following colors to the systems listed below:
 - a. Fire Alarm System: Red.
 - b. Fire-Suppression Supervisory and Control System: Red and yellow.
 - c. Combined Fire Alarm and Security System: Red and blue.
 - d. Security System: Blue and yellow.
 - e. Mechanical and Electrical Supervisory System: Green and blue.
 - f. Telecommunication System: Green and yellow.
- H. Caution Labels for Indoor Boxes and Enclosures for Power and Lighting: Install pressure-sensitive, self-adhesive labels identifying system voltage with black letters on orange background. Install on exterior of door or cover.
- I. Circuit Identification Labels on Boxes: Install labels externally.
 - 1. Exposed Boxes: Pressure-sensitive, self-adhesive plastic label on cover.
 - 2. Concealed Boxes: Plasticized card-stock tags.

Weedsport Addition to Maintenance Section and Roof Replacement, MP 304.2

3. Labeling Legend: Permanent, waterproof listing of panel and circuit number or equivalent.
- J. Paths of Underground Electrical Lines: During trench backfilling, for exterior underground power, control, signal, and communication lines, install continuous underground plastic line marker located directly above line at 6 to 8 inches below finished grade. Where width of multiple lines installed in a common trench or concrete envelope does not exceed 16 inches overall, use a single line marker. Install line marker for underground wiring, both direct-buried cables and cables in raceway.
- K. Secondary Service, Feeder, and Branch-Circuit Conductors: Color-code throughout the secondary electrical system.
1. Color-code 208/120-V system as follows:
 - a. Phase A: Black.
 - b. Phase B: Red.
 - c. Phase C: Blue.
 - d. Neutral: White.
 - e. Ground: Green.
 2. Color-code 480/277-V system as follows:
 - a. Phase A: Yellow.
 - b. Phase B: Brown.
 - c. Phase C: Orange.
 - d. Neutral: White with a colored stripe or gray.
 - e. Ground: Green.
 3. Factory apply color the entire length of conductors, except the following field-applied, color-coding methods may be used instead of factory-coded wire for sizes larger than No. 10 AWG:
 - a. Colored, pressure-sensitive plastic tape in half-lapped turns for a distance of 6 inches from terminal points and in boxes where splices or taps are made. Apply last two turns of tape with no tension to prevent possible unwinding. Use 1-inch-wide tape in colors specified. Adjust tape bands to avoid obscuring cable identification markings.
- L. Power-Circuit Identification: Metal tags or aluminum, wraparound marker bands for cables, feeders, and power circuits in vaults, pull and junction boxes, manholes, and switchboard rooms.
1. Legend: 1/4-inch- steel letter and number stamping or embossing with legend corresponding to indicated circuit designations.
 2. Tag Fasteners: Nylon cable ties.
 3. Band Fasteners: Integral ears.
- M. Apply identification to conductors as follows:
1. Conductors to Be Extended in the Future: Indicate source and circuit numbers.
 2. Multiple Power or Lighting Circuits in the Same Enclosure: Identify each conductor with source, voltage, circuit number, and phase. Use color-coding to identify circuits' voltage and phase.
 3. Multiple Control and Communication Circuits in the Same Enclosure: Identify each conductor by its system and circuit designation. Use a consistent system of tags, color-coding, or cable marking tape.

Weedsport Addition to Maintenance Section and Roof Replacement, MP 304.2

- N. Apply warning, caution, and instruction signs as follows:
1. Warnings, Cautions, and Instructions: Install to ensure safe operation and maintenance of electrical systems and of items to which they connect. Install engraved plastic-laminated instruction signs with approved legend where instructions are needed for system or equipment operation. Install metal-backed butyrate signs for outdoor items.
 2. Emergency Operation: Install engraved laminated signs with white legend on red background with minimum 3/8-inch- high lettering for emergency instructions on power transfer, load shedding, and other emergency operations.
- O. Equipment Identification Labels: Engraved plastic laminate. Install on each unit of equipment, including central or master unit of each system. This includes power, lighting, communication, signal, and alarm systems, unless units are specified with their own self-explanatory identification. Unless otherwise indicated, provide a single line of text with 1/2-inch- high lettering on 1-1/2-inch- high label; where two lines of text are required, use labels 2 inches high. Use white lettering on black field. Apply labels for each unit of the following categories of equipment using mechanical fasteners:
1. Panelboards, electrical cabinets, and enclosures.
 2. Access doors and panels for concealed electrical items.
 3. Electrical switchgear and switchboards.
 4. Electrical substations.
 5. Emergency system boxes and enclosures.
 6. Motor-control centers.
 7. Disconnect switches.
 8. Enclosed circuit breakers.
 9. Motor starters.
 10. Push-button stations.
 11. Power transfer equipment.
 12. Contactors.
 13. Remote-controlled switches.
 14. Dimmers.
 15. Control devices.
 16. Transformers.
 17. Inverters.
 18. Rectifiers.
 19. Frequency converters.
 20. Battery racks.
 21. Power-generating units.
 22. Telephone switching equipment.
 23. Clock/program master equipment.
 24. Call system master station.
 25. TV/audio-monitoring master station.
 26. Fire alarm master station or control panel.
 27. Security-monitoring master station or control panel.

END OF SECTION 260553

THIS PAGE INTENTIONALLY LEFT BLANK

SECTION 260923 – LIGHTING CONTROL DEVICES

PART 1 - GENERAL

1.1 RELATED DOCUMENTS

- A. Drawings and general provisions of the Contract, including General and Supplementary Conditions and Division 01 Specification Sections, apply to this Section.

1.2 SUMMARY

- A. Section Includes:
1. Time switches.
 2. Photoelectric switches.
 3. Indoor occupancy sensors.
 4. Indoor vacancy sensors.
 5. Dimming switches.
 6. Lighting contactors.
- B. Related Requirements:
1. Section 262726 "Wiring Devices" for wall-box dimmers, manual light switches, and color/finish of devices and faceplates.

1.3 ACTION SUBMITTALS

- A. Product Data: For each type of product.
- B. Shop Drawings: Show installation details for occupancy sensors.
1. Interconnection diagrams showing field-installed wiring.
 2. Include diagrams for power, signal, and control wiring.

1.4 CLOSEOUT SUBMITTALS

- A. Operation and Maintenance Data: For each type of lighting control device to include in emergency, operation, and maintenance manuals.

PART 2 - PRODUCTS

2.1 TIME SWITCHES

- A. Manufacturers: Subject to compliance with requirements, available manufacturers offering products that may be incorporated into the Work include, but are not limited to, the following:
1. Intermatic, Inc.
 2. Cooper Industries, Inc.
 3. Invensys Controls.
 4. Leviton Mfg. Company Inc.
 5. NSi Industries LLC; TORK Products.
 6. Tyco Electronics; ALR Brand.
- B. Electronic Time Switches: Solid state, programmable, with alphanumeric display; complying with UL 917.
1. Listed and labeled as defined in NFPA 70, by a qualified testing agency, and marked for intended location and application.

Weedsport Addition to Maintenance Section and Roof Replacement, MP 304.2

2. Contact Configuration: As indicated on drawings.
3. Contact Rating: As indicated on drawings.
4. Programs: As indicated on drawings.
5. Switch to include 2 independent outputs for separate circuit programming.
6. Circuitry: Allow connection of a photoelectric relay as substitute for on-off function of a program
7. Astronomic Time: All channels.
8. Automatic daylight savings time changeover.
9. Battery Backup: Not less than seven days reserve, to maintain schedules and time clock.
10. Intermatic ET270 Series.

2.2 OUTDOOR PHOTOELECTRIC SWITCHES

- A. Manufacturers: Subject to compliance with requirements, provide products by one of the following:
1. Cooper Industries, Inc.
 2. Intermatic, Inc.
 3. NSi Industries LLC; TORK Products.
 4. Tyco Electronics; ALR Brand.
 5. Paragon.
- B. Description: Solid state, with SPST or DPST dry contacts rated for 1800-VA tungsten or 1000-VA inductive, to operate connected relay, contactor coils, or microprocessor input; complying with UL 773A.
1. Listed and labeled as defined in NFPA 70, by a qualified testing agency, and marked for intended location and application.
 2. Light-Level Monitoring Range: 1.5 to 10 fc, with an adjustment for turn-on and turn-off levels within that range, and a directional lens in front of the photocell to prevent fixed light sources from causing turn-off.
 3. Time Delay: Fifteen second minimum, to prevent false operation.
 4. Surge Protection: Metal-oxide varistor.
 5. Mounting: Twist lock complies with NEMA C136.10, with base-and-stem mounting or stem-and-swivel mounting accessories as required to direct sensor to the north sky exposure.

2.3 DAYLIGHT-HARVESTING DIMMING CONTROLS

- A. System Description: Sensing daylight and electrical lighting levels, the system adjusts the indoor electrical lighting levels. As daylight increases, the lights are dimmed.
1. Lighting control set point is based on two lighting conditions:
 - a. When no daylight is present (target level).
 - b. When significant daylight is present.
 2. System programming is done with two hand-held, remote-control tools.
 - a. Initial setup tool.
 - b. Tool for occupants to adjust the target levels by increasing the set point up to 25 percent, or by minimizing the electric lighting level.
- B. Ceiling-Mounted Dimming Controls: Solid-state, light-level sensor unit, with integrated or separate power pack, to detect changes in indoor lighting levels that are perceived by the eye.
- C. Electrical Components, Devices, and Accessories:

Weedsport Addition to Maintenance Section and Roof Replacement, MP 304.2

1. Listed and labeled as defined in NFPA 70, by a qualified testing agency, and marked for intended location and application.
 2. Sensor Output: 0- to 10-V dc to operate luminaires. Sensor is powered by controller unit.
 3. Light-Level Sensor Set-Point Adjustment Range: 20 to 100 fc (120 to 1080 lux).
- D. Power Pack: Dry contacts rated for 20-A load at 120- and 277-V ac. Sensor has 24-V dc, 150-mA, Class 2 power source, as defined by NFPA 70.
1. LED status lights to indicate load status.
 2. Plenum rated.
- E. Power Pack: Digital controller capable of accepting RJ45 inputs with two outputs rated for 20-A load at 120- and 277-V ac. Sensor has 24-V dc Class 2 power source, as defined by NFPA 70.
1. With integral current monitoring
 2. Compatible with digital addressable lighting interface.
 3. Plenum rated.

2.4 INDOOR OCCUPANCY SENSORS

- A. Manufacturers: Subject to compliance with requirements, available manufacturers offering products that may be incorporated into the Work include, but are not limited to, the following:
1. Hubbell Lighting Controls.
 2. Greengate Lighting Controls.
 3. Cooper Industries.
 4. Lithonia Lighting; Acuity Lighting Group, Inc.
 5. Lutron Electronics Co., Inc.
 6. Sensor Switch, Inc.
 7. Watt Stopper.
- B. General
1. Occupancy sensors shall control lighting in the controlled area only.
 2. The contractor shall be responsible for a complete, operable system, providing the control as indicated on the drawings, and installation should be warranted for a period of one (1) year after owner's acceptance.
 3. Drawings show devices required for operational intent. It will be the responsibility of the contractor to provide the correct digital solution where required. For clarity, all components are not shown on plan.
 4. The product shall be warranted for a period of five (5) years for wall switch sensors, ceiling sensors and power packs.
 5. Occupancy sensors shall be installed as per manufacturer's recommendations.
 6. The specified manufacturers have different types of sensors with different areas of coverage. The contractor shall be responsible for contacting the manufacturer for proper placement and adjustment of sensor. Drawings indicate general locations of sensors to indicate area of control only.
 7. The contractor shall provide additional sensors and control units as necessary to provide control of the indicated area.
 8. Individual room sensors shall not be activated by motion outside of the room when the room door is open.
 9. Sensors shall be provided with auxiliary contacts for HVAC fan occupancy control.
- C. General Requirements for Sensors: Wall- or ceiling-mounted, solid-state indoor occupancy sensors with a separate power pack.

Weedsport Addition to Maintenance Section and Roof Replacement, MP 304.2

1. Listed and labeled as defined in NFPA 70, by a qualified testing agency, and marked for intended location and application.
 2. Operation: Unless otherwise indicated, turn lights on when coverage area is occupied, and turn them off when unoccupied; with a time delay for turning lights off, adjustable over a minimum range of 1 to 30 minutes.
 3. Sensor Output: Contacts rated to operate the connected relay, complying with UL 773A. Sensor is powered from the power pack.
 4. Power Pack: Dry contacts rated for 20-A ballast load at 120- and 277-V ac, for 13-A tungsten at 120-V ac, and for 1 hp at 120-V ac. Sensor has 24-V dc, 150-mA, Class 2 power source, as defined by NFPA 70.
 5. Mounting:
 - a. Sensor: Suitable for mounting in any position on a standard outlet box.
 - b. Relay: Externally mounted through a 1/2-inch knockout in a standard electrical enclosure.
 - c. Time-Delay and Sensitivity Adjustments: Recessed and concealed behind hinged door.
 6. Indicator: Digital display, to show when motion is detected during testing and normal operation of sensor.
 7. Bypass Switch: Override the "on" function in case of sensor failure.
 8. Automatic Light-Level Sensor: Adjustable from 2 to 200 fc; turn lights off when selected lighting level is present.
 9. Dual Relay Units: Shall have provisions for setting both relays to turn on when occupancy is detected. Units that allow only one relay to default to "on" are not acceptable.
 10. Occupancy sensor to be compatible with all other lighting controls and light fixtures in room. Contractor and lighting supplier to verify coordination prior to submittal and shall be responsible to replace any devices that do not operate as intended.
- D. Ceiling Mounted Occupancy Sensor for Low Voltage Dimming:
1. Dual-Technology Type. Uses a combination of passive-infrared and ultrasonic detection methods to distinguish between occupied and unoccupied conditions for area covered.
 2. Provides dimming outputs to control 0-10Vdc dimmable drivers.
 3. Follows dimming commands from nLight Wallpod dimmer or SensorView software.
 4. Capable to communicate with other nLight devices over Cat5e cable.
 5. Adds 20 AWG violet & gray wires.
 6. Extended range (28' radius, 360 degrees) coverage pattern
 7. Compatible with LED dimming drivers
 8. Auto dimming control photocell.
- E. Dual-Technology Type: Ceiling mounted; detect occupants in coverage area using PIR and ultrasonic detection methods. The particular technology or combination of technologies that control on-off functions is selectable in the field by operating controls on unit.
1. Sensitivity Adjustment: Separate for each sensing technology.
 2. Detector Sensitivity: Detect occurrences of 6-inch- minimum movement of any portion of a human body that presents a target of not less than 36 sq. in., and detect a person of average size and weight moving not less than 12 inches in either a horizontal or a vertical manner at an approximate speed of 12 inches/s.
 3. Detection Coverage (Small Room): Detect occupancy anywhere within a circular area of 600 sq. ft. when mounted on a 96-inch- high ceiling.
 4. Detection Coverage (Standard Room): Detect occupancy anywhere within a circular area of 1000 sq. ft. when mounted on a 96-inch- high ceiling.

Weedsport Addition to Maintenance Section and Roof Replacement, MP 304.2

5. Detection Coverage (Large Room): Detect occupancy anywhere within a circular area of 2000 sq. ft. when mounted on a 96-inch- high ceiling.
 6. Ceiling sensor to be provided with isolated relay for integration with Building HVAC management system.
- F. Ceiling Mounted "Hi-Bay" Occupancy Sensors
1. Suitable for gymnasium and similar type occupancies.
 2. 0-10v dimming PIR Occupancy Sensor
 3. Leviton model #HBE11-IUB with 360 degree high mount lens Leviton Model #HBLNH-360.
 4. 5 year warranty.
- G. Wall Mounted Dual-Technology Occupancy Sensor:
1. Dual-Technology Type.
 2. 2500 square-foot coverage pattern.
 3. Wall mounting bracket.
- H. Ceiling Mounted Occupancy Sensor with Integral Photocell:
1. Passive Infrared Technology Type.
 2. Extended range (20' radius, 360 degrees), 1500 square-foot coverage pattern.
 3. Auto control photocell prevents lights from coming on if adequate daylight is available.
 4. UL and cUL Listed and labeled.
 5. Sensitivity adjustment 20%-100%
 6. Line Voltage Input.
 7. General Space Sensors Light-Level Monitoring Range: 5 to 200 fc, with an adjustment for turn-on and turn-off levels within that range.
 8. Time Delay: Adjustable from 30 seconds to 30 minutes.
 9. Set-Point Adjustment: Equip with deadband adjustment of 25, 50, and 75 percent above the "on" set point, or provide with separate adjustable "on" and "off" set points.
 10. Walk test indicator light.
 11. Color to be white.
 12. Manufacturer: Hubbell Building Automation, Inc., Model # PIR10P. .

2.5 SWITCHBOX-MOUNTED OCCUPANCY SENSORS

- A. Manufacturers: Subject to compliance with requirements, available manufacturers offering products that may be incorporated into the Work include, but are not limited to, the following:
1. Hubbell Lighting Controls.
 2. Greengate Lighting Controls.
 3. Cooper Industries, Inc.
 4. Lithonia Lighting; Acuity Lighting Group, Inc.
 5. Lutron Electronics Co., Inc.
 6. Sensor Switch, Inc.
 7. Watt Stopper.
- B. General Requirements for Sensors: Automatic-wall-switch occupancy sensor, suitable for mounting in a single gang switchbox.
- C. Vacancy Sensor with integral 0-10v manual dimming control.
1. Listed and labeled as defined in NFPA 70, by a qualified testing agency, and marked for intended location and application.
 2. Operating Ambient Conditions: Dry interior conditions, 32 to 120 deg F.
 3. Switch Rating: Not less than 800-VA fluorescent/LED at 120 V and 1200-VA fluorescent/LED at 277 V.

Weedsport Addition to Maintenance Section and Roof Replacement, MP 304.2

4. Standard Range: 180-degree field of view, field adjustable from 180 to 40 degrees; with a minimum coverage area of 900 sq. ft.
5. Sensing Technology: Dual technology (PIR and ultrasonic).
6. Switch Type: Single-relay or dual-relay, as indicated on drawing.
 - a. Dual-Relay Units: Shall have provisions for setting both relays to turn on when occupancy is detected. Units that allow only one relay to default to "on" are not acceptable.
7. Voltage: Match the circuit voltage.
8. Ambient-Light Override: Concealed, field-adjustable, light-level sensor from 10 to 150 fc. The switch prevents the lights from turning on when the light level is higher than the set point of the sensor.
9. Concealed, field-adjustable, "off" time-delay selector at up to 30 minutes.
10. Concealed "off" time-delay selector at 30 seconds, and 5, 10, and 20 minutes.
11. Adaptive Technology: Self-adjusting circuitry detects and memorizes usage patterns of the space and helps eliminate false "off" switching.
12. Color/finish shall match that of other wiring devices in the project.
13. Sensor to be compatible with all other lighting controls and light fixtures in room. Contractor and lighting supplier to verify coordination prior to submittal and shall be responsible to replace any devices that do not operate as intended.

2.6 LIGHTING CONTACTORS

- A. Manufacturers: Subject to compliance with requirements, available manufacturers offering products that may be incorporated into the Work include, but are not limited to, the following:
 1. Allen-Bradley/Rockwell Automation.
 2. ASCO Power Technologies, LP; a division of Emerson Electric Co.
 3. Eaton Corporation.
 4. General Electric Company; GE Consumer & Industrial - Electrical Distribution; Total Lighting Control.
 5. Square D; a brand of Schneider Electric.
- B. Description: Electrically operated and electrically held, combination-type lighting contactors, complying with NEMA ICS 2 and UL 508.
 1. Current Rating for Switching: Listing or rating consistent with type of load served, including tungsten filament, inductive, and high-inrush ballast (ballast with 15 percent or less total harmonic distortion of normal load current).
 2. Fault Current Withstand Rating: Equal to or exceeding the available fault current at the point of installation.
 3. Enclosure: Comply with NEMA 250.
 4. Provide with control and pilot devices as indicated on Drawings, matching the NEMA type specified for the enclosure.

2.7 DIMMER SWITCH

- A. Description: Wall box dimmer switch.
 1. On/Off switch with buttons or slider to raise/lower light level.
 2. 0-10v dimming control.
 3. Compatible with associated dimming driver in luminaire.
 4. Finish of decorator switch to be ivory.
 5. Wall plate to be satin-finished stainless steel.
 6. Multiple gang face plates to accommodate quantity of switches required.

Weedsport Addition to Maintenance Section and Roof Replacement, MP 304.2

7. Provide additional components (digital room system, power supplies, etc.) if required to wire system.
8. Manufacturers:
 - a. Wattstopper, Inc.
 - b. Lutron
 - c. Hunt Dimming

2.8 LOW VOLTAGE WALL MOUNTED OCCUPANCY SENSOR WITH DIMMING CONTROL

- A. Description: Low voltage occupancy sensor wall switch with buttons for on/off, raise light level, and lower light level.
1. Dual-Technology Type. Uses a combination of passive-infrared and ultrasonic detection methods to distinguish between occupied and unoccupied conditions for area covered. Particular technology or combination of technologies that controls each function (on or off) is selectable in the field by operating controls on unit.
 2. 0-10v dimming control.
 3. Capable to communicate with other nLight devices over Cat5e cable.
 4. Capable to control other 0-10v drivers.
 5. Adds 20 AWG violet & gray wires.
 6. Finish of decorator switch to be ivory. Finish of faceplate to be satin-finished stainless steel. Size of plate to be dependent upon existing/new box size.
 7. Sensorswitch, Model #nWSX LV DX IV

2.9 LOW VOLTAGE DIMMING SWITCH

- A. Description: Low voltage wall switch with buttons for on/off, raise light level, and lower light level.
1. 0-10v dimming control.
 2. Capable to communicate with other nLight devices over Cat5e cable.
 3. Capable to control other 0-10v drivers.
 4. Adds 20 AWG violet & gray wires.
 5. Finish of decorator switch to be ivory. Finish of faceplate to be satin-finished stainless steel. Size of plate to be dependent upon existing/new box size.
 6. Sensorswitch, Model #nPODM DX IV

2.10 AUXILIARY RELAY

- A. Description: Auxiliary relay pack that enables switching of low voltage interface with non-nLight devices or control systems.
1. Capable to communicate with nLight Network over Cat 5e cable
 2. Remotely Configurable/Upgradeable
 3. Push-Button Programmable
 4. Reversible Relay Logic
 5. Green LED Indicator
 6. Two RJ-45 connectors for Cat 5e cabling
 7. Can be daisy chained with nLight-enabled power packs, sensor and/or WallPods in an nLight control zone.
 8. Operational Settings.
 - a. Override (On/Off/Normal)
 - b. Occupancy Tracking (Enable/Disable)

Weedsport Addition to Maintenance Section and Roof Replacement, MP 304.2

- c. Photocell Tracking (Enable/Disable)
 - d. Switch Tracking (Enable/Disable)
 - e. Occupancy Tracking Channel (1-16)
 - f. Photocell Tracking Channel (1-16)
 - g. Switch Tracking Channel (1-16)
 - h. Button Mode (Enable/Disable)
 - i. Start to High (Enable/Disable)
 - j. Invert Relay Logic (Enable/Disable)
 - k. LED (Override On/Override Off/Normal)
- 9. Special Modes: Manual On to Auto off (Semi-Auto), Auto to (Timed) Override On, Manual to (Timed) Override On, Manual On to Full Auto, Predictive off.
 - 10. Sensorswitch, Model #nAR40

2.11 CONDUCTORS AND CABLES

- A. Power Wiring to Supply Side of Remote-Control Power Sources: Not smaller than No. 12 AWG. Comply with requirements in Section 260519 "Low-Voltage Electrical Power Conductors and Cables."
- B. Classes 2 and 3 Control Cable: Multiconductor cable with stranded-copper conductors not smaller than No. 18 AWG. Comply with requirements in Section 260519 "Low-Voltage Electrical Power Conductors and Cables."
- C. Class 1 Control Cable: Multiconductor cable with stranded-copper conductors not smaller than No. 14 AWG. Comply with requirements in Section 260519 "Low-Voltage Electrical Power Conductors and Cables."

PART 3 - EXECUTION**3.1 SENSOR INSTALLATION**

- A. Coordinate layout and installation of ceiling-mounted devices with other construction that penetrates ceilings or is supported by them, including light fixtures, HVAC equipment, smoke detectors, fire-suppression systems, and partition assemblies.
- B. Install and aim sensors in locations to achieve not less than 90 percent coverage of areas indicated. Do not exceed coverage limits specified in manufacturer's written instructions.

3.2 WIRING INSTALLATION

- A. Wiring Method: Comply with Section 260519 "Low-Voltage Conductors and Cables." Minimum conduit size is 1/2 inch.
- B. Wiring within Enclosures: Comply with NECA 1. Separate power-limited and nonpower-limited conductors according to conductor manufacturer's written instructions.
- C. Size conductors according to lighting control device manufacturer's written instructions unless otherwise indicated.
- D. Splices, Taps, and Terminations: Make connections only on numbered terminal strips in junction, pull, and outlet boxes; terminal cabinets; and equipment enclosures.

3.3 IDENTIFICATION

- A. Identify components and power and control wiring according to Section 260553 "Identification for Electrical Systems."

Weedsport Addition to Maintenance Section and Roof Replacement, MP 304.2

3.4 FIELD QUALITY CONTROL

- A. Perform the following tests and inspections:
 - 1. Operational Test: After installing and sensors, and after electrical circuitry has been energized, start units to confirm proper unit operation.
 - 2. Test and adjust controls and safeties. Replace damaged and malfunctioning controls and equipment.
- B. Lighting control devices will be considered defective if they do not pass tests and inspections.

3.5 ADJUSTING

- A. Occupancy Adjustments: When requested within 12 months from date of Substantial Completion, provide on-site assistance in adjusting sensors to suit actual occupied conditions. Provide up to two visits to Project during other-than-normal occupancy hours for this purpose.
 - 1. For occupancy and motion sensors, verify operation at outer limits of detector range. Set time delay to suit Owner's operations.

3.6 DEMONSTRATION

- A. Train Owner's maintenance personnel to adjust, operate, and maintain lighting control devices.

END OF SECTION 260923

THIS PAGE INTENTIONALLY LEFT BLANK

SECTION 262616 - ENCLOSED SWITCHES AND CIRCUIT BREAKERS

PART 1 - GENERAL

1.1 RELATED DOCUMENTS

- A. Drawings and general provisions of the Contract, including General and Supplementary Conditions and Division 1 Specification Sections, apply to this Section.

1.2 SUMMARY

- A. This Section includes individually mounted enclosed switches and circuit breakers used for the following:
 - 1. Service disconnecting means.
 - 2. Feeder and branch-circuit protection.
 - 3. Motor and equipment disconnecting means.
- B. Related Sections include the following:
 - 1. Division 26 Section "Wiring Devices" for attachment plugs, receptacles, and toggle switches used for disconnecting means.
 - 2. Division 26 Section "Fuses" for fusible devices.

1.3 DEFINITIONS

- A. GFCI: Ground-fault circuit interrupter.
- B. RMS: Root mean square.
- C. SPDT: Single pole, double throw.

1.4 SUBMITTALS

- A. Product Data: For each type of switch, circuit breaker, accessory, and component indicated. Include dimensions and manufacturers' technical data on features, performance, electrical characteristics, ratings, and finishes.
- B. Shop Drawings: For each switch and circuit breaker.
 - 1. Dimensioned plans, elevations, sections, and details, including required clearances and service space around equipment. Show tabulations of installed devices, equipment features, and ratings. Include the following:
 - a. Enclosure types and details for types other than NEMA 250, Type 1.
 - b. Current and voltage ratings.
 - c. Short-circuit current rating.
 - d. UL listing for series rating of installed devices.
 - e. Features, characteristics, ratings, and factory settings of individual overcurrent protective devices and auxiliary components.
 - 2. Wiring Diagrams: Power, signal, and control wiring. Differentiate between manufacturer-installed and field-installed wiring.
- C. Manufacturer Seismic Qualification Certification: Submit certification that enclosed switches and circuit breakers, accessories, and components will withstand seismic forces. Include the following:
 - 1. Basis of Certification: Indicate whether withstand certification is based on actual test of assembled components or on calculation.

WeedSPORT Addition to Maintenance Section and Roof Replacement, MP 304.2

- a. The term "withstand" means "the unit will remain in place without separation of any parts from the device when subjected to the seismic forces specified and the unit will be fully operational after the seismic event."
 - 2. Dimensioned Outline Drawings of Equipment Unit: Identify center of gravity and locate and describe mounting and anchorage provisions.
 - 3. Detailed description of equipment anchorage devices on which the certification is based and their installation requirements.
- D. Qualification Data: Submit data for testing agencies indicating that they comply with qualifications specified in "Quality Assurance" Article.
- E. Field Test Reports: Submit written test reports and include the following:
- 1. Test procedures used.
 - 2. Test results that comply with requirements.
 - 3. Results of failed tests and corrective action taken to achieve test results that comply with requirements.
- F. Manufacturer's field service report.
- G. Maintenance Data: For enclosed switches and circuit breakers and for components to include in maintenance manuals specified in Division 1. In addition to requirements specified in Division 1, include the following:
- 1. Routine maintenance requirements for components.
 - 2. Manufacturer's written instructions for testing and adjusting switches and circuit breakers.
 - 3. Time-current curves, including selectable ranges for each type of circuit breaker.

1.5 QUALITY ASSURANCE

- A. Testing Agency Qualifications: Testing agency that is a member company of the InterNational Electrical Testing Association and that is acceptable to authorities having jurisdiction.
- 1. Testing Agency's Field Supervisor: Person currently certified by the InterNational Electrical Testing Association or National Institute for Certification in Engineering Technologies to supervise on-site testing specified in Part 3.
- B. Electrical Components, Devices, and Accessories: Listed and labeled as defined in NFPA 70, Article 100, by a testing agency acceptable to authorities having jurisdiction, and marked for intended use.
- C. Comply with NEMA AB 1 and NEMA KS 1.
- D. Comply with NFPA 70.
- E. Product Selection for Restricted Space: Drawings indicate maximum dimensions for enclosed switches and circuit breakers, including clearances between enclosures, and adjacent surfaces and other items. Comply with indicated maximum dimensions.

1.6 PROJECT CONDITIONS

- A. Environmental Limitations: Rate equipment for continuous operation under the following conditions, unless otherwise indicated:
- 1. Ambient Temperature: Not less than minus 22 deg F and not exceeding 104 deg F.
 - 2. Altitude: Not exceeding 6600 feet.

1.7 COORDINATION

- A. Coordinate layout and installation of switches, circuit breakers, and components with other construction, including conduit, piping, equipment, and adjacent surfaces. Maintain required workspace clearances and required clearances for equipment access doors and panels.
- B. Verify existing panelboard KAIC ratings for installation of new breakers. New breakers to be added to existing panelboards shall be U.L. listed/labeled for use with the existing panelboards. Interrupting rating of new breakers shall match rating of existing associated panelboard.

1.8 EXTRA MATERIALS

- A. Furnish extra materials described below that match products installed and that are packaged with protective covering for storage and identified with labels describing contents.
 - 1. Spares: For the following:
 - a. Control-Power Fuses: 2
 - b. Fuses for Fused Switches: 2
 - 2. Spare Indicating Lights: Six of each type installed.

PART 2 - PRODUCTS**2.1 MANUFACTURERS**

- A. Manufacturers: Subject to compliance with requirements, provide products by one of the following:
 - 1. Square D Co.
 - 2. Eaton Corp.; Cutler-Hammer Products.

2.2 ENCLOSED SWITCHES

- A. Enclosed, Nonfusible Switch: NEMA KS 1, Type HD, with lockable handle.
- B. Enclosed, Fusible Switch, 800 A and Smaller: NEMA KS 1, Type HD, with clips to accommodate specified fuses, lockable handle with two padlocks, and interlocked with cover in closed position.

2.3 ENCLOSURES

- A. NEMA AB 1 and NEMA KS 1 to meet environmental conditions of installed location.
 - 1. Outdoor Locations: NEMA 250, Type 3R.
 - 2. Kitchen Areas: NEMA 250, Type 4X, stainless steel.
 - 3. Other Wet or Damp Indoor Locations: NEMA 250, Type 4.
 - 4. Hazardous Areas Indicated on Drawings: NEMA 250, Type 7C.

2.4 FACTORY FINISHES

- A. Manufacturer's standard prime-coat finish ready for field painting.
- B. Finish: Manufacturer's standard gray paint applied to factory-assembled and -tested enclosures before shipping.

PART 3 - EXECUTION

3.1 EXAMINATION

- A. Examine elements and surfaces to receive enclosed switches and circuit breakers for compliance with installation tolerances and other conditions affecting performance.
 - 1. Proceed with installation only after unsatisfactory conditions have been corrected.

3.2 INSTALLATION

- A. Temporary Lifting Provisions: Remove temporary lifting eyes, channels, and brackets and temporary blocking of moving parts from enclosures and components.

3.3 IDENTIFICATION

- A. Identify field-installed conductors, interconnecting wiring, and components; provide warning signs as specified in Division 26 Section "Electrical Identification".
- B. Enclosure Nameplates: Label each enclosure with engraved metal or laminated-plastic nameplate mounted with corrosion-resistant screws.

3.4 CONNECTIONS

- A. Install equipment grounding connections for switches and circuit breakers with ground continuity to main electrical ground bus.
- B. Install power wiring. Install wiring between switches and circuit breakers, and control and indication devices.
- C. Tighten electrical connectors and terminals according to manufacturer's published torque-tightening values. If manufacturer's torque values are not indicated, use those specified in UL 486A and UL 486B.

3.5 FIELD QUALITY CONTROL

- A. Prepare for acceptance tests as follows:
 - 1. Test insulation resistance for each enclosed switch, circuit breaker, component, and control circuit.
 - 2. Test continuity of each line- and load-side circuit.
- B. Testing: After installing enclosed switches and circuit breakers and after electrical circuitry has been energized, demonstrate product capability and compliance with requirements.
 - 1. Procedures: Perform each visual and mechanical inspection and electrical test indicated in NETA ATS, Section 7.5 for switches. Certify compliance with test parameters.
 - 2. Correct malfunctioning units on-site, where possible, and retest to demonstrate compliance; otherwise, replace with new units and retest.
- C. Infrared Scanning: After Substantial Completion, but not more than 60 days after Final Acceptance, perform an infrared scan of each enclosed switch and circuit breaker. Open or remove doors or panels so connections are accessible to portable scanner.
 - 1. Follow-up Infrared Scanning: Perform an additional follow-up infrared scan of each unit 11 months after date of Substantial Completion.
 - 2. Instrument: Use an infrared scanning device designed to measure temperature or to detect significant deviations from normal values. Provide calibration record for device.

Weedsport Addition to Maintenance Section and Roof Replacement, MP 304.2

3. Record of Infrared Scanning: Prepare a certified report that identifies switches and circuit breakers checked and that describes scanning results. Include notation of deficiencies detected, remedial action taken and observations after remedial action.

3.6 CLEANING

- A. On completion of installation, inspect interior and exterior of enclosures. Remove paint splatters and other spots. Vacuum dirt and debris; do not use compressed air to assist in cleaning. Repair exposed surfaces to match original finish.

END OF SECTION 262616

THIS PAGE INTENTIONALLY LEFT BLANK

SECTION 262726 - WIRING DEVICES

PART 1 - GENERAL

1.1 RELATED DOCUMENTS

- A. Drawings and general provisions of the Contract, including General and Supplementary Conditions and Division 1 Specification Sections, apply to this Section.

1.2 SUMMARY

- A. This Section includes receptacles, switches, finish plates, hand dryers, and carbon monoxide detectors.

1.3 DEFINITIONS

- A. GFCI: Ground-fault circuit interrupter.

1.4 SUBMITTALS

- A. Product Data: For each product specified.
- B. Shop Drawings: Legends for receptacles and switch plates.
- C. Samples: For devices and device plates for color selection and evaluation of technical features.
- D. Maintenance Data: For materials and products to include in maintenance manuals specified in Division 1.

1.5 QUALITY ASSURANCE

- A. Electrical Components, Devices, and Accessories: Listed and labeled as defined in NFPA 70, Article 100, by a testing agency acceptable to authorities having jurisdiction.
- B. Comply with NEMA WD 1.
- C. Comply with NFPA 70.

1.6 COORDINATION

- A. Receptacles for Owner-Furnished Equipment: Match plug configurations.
 - 1. Cord and Plug Sets: Match equipment requirements.

PART 2 - PRODUCTS

2.1 MANUFACTURERS

- A. Manufacturers: Subject to compliance with requirements, provide products by one of the following:
 - 1. Wiring Devices:
 - a. Pass & Seymour/Legrand; Wiring Devices Div.
 - b. Hubbell, Inc.; Wiring Devices Div.

Weedsport Addition to Maintenance Section and Roof Replacement, MP 304.2

2.2 RECEPTACLES

- A. Straight-Blade Receptacles: 20 amp, 125 volts, 2 pole, 3 wire, U ground slot, Heavy-Duty Specification Grade. Ivory in color
- B. GFCI Receptacles: Feed-through type, with integral NEMA WD 6, Configuration 5-20R duplex receptacle, arranged to protect connected downstream receptacles on same circuit. Design units for installation in a 2-3/4-inch- deep outlet box without an adapter. Heavy-Duty Specification Grade. Ivory in color.
- C. Transient Voltage Surge Suppressor Receptacles (TVSS): Designated on drawings as SS.
 - 1. Modes of protection: L-G, L-N, N-G.
 - 2. Each mode protected by two MOV's.
 - 3. UL protection level of 500V in each mode with maximum clamping voltage of 420V.
 - 4. Blue finish
 - 5. LED on face lighted when protection is intact.
 - 6. Meets UL Standard 1449 second edition.
 - 7. NEMA 5-20R, 20 amp, 125 volt.
 - 8. Arrow Hart #535OS or equal.
- D. Straight-Blade Tamper Resistant Receptacles: 20 amp, 125 volts, 2 pole, 3 wire, U ground slot, Heavy-Duty Specification Grade. Dual mechanism shutter system to help prevent insertion of foreign objects. Ivory in color.
- E. Weather Resistant Receptacles: Outdoor grade, UL listed weather-resistant to comply with Section 406.8 of the 2008 National Electrical Code. Constructed with UV stabilized engineering thermoplastic for high cold impact resistance.

2.3 TWIST-LOCKING RECEPTACLES

- A. Single Convenience Receptacles, 125 V, 20 A: Comply with NEMA WD 1, NEMA WD 6 configuration L5-20R, and UL 498.
 - 1. Available Products: Subject to compliance with requirements, products that may be incorporated into the Work include, but are not limited to, the following:
 - 2. Products: Subject to compliance with requirements, provide one of the following:
 - a. Cooper; L520R.
 - b. Hubbell; HBL2310.
 - c. Leviton; 2310.
 - d. Pass & Seymour; L520-R.

2.4 SWITCHES

- A. Snap Switches, 120/277v: Quiet slow make, slow break design, toggle handle with totally enclosed case, rated 20 amp, specification grade. Provide matching two pole, 3 way, and 4 way switches.
- B. Grounding Combination Switches: Rated 20 amp, specification grade, two single pole switches. For use where two switches shall be installed in existing single gang device box to accommodate inboard/outboard switching.
- C. Single and Double-Pole Switches: Comply with DSCC W-C-896F and UL 20.
- D. All switches shall be ivory in color.

Weedsport Addition to Maintenance Section and Roof Replacement, MP 304.2

2.5 WALL PLATES

- A. Single and combination types match corresponding wiring devices.
 - 1. Plate-Securing Screws: Metal with head color to match plate finish.
 - 2. Material for Finished Spaces: 0.04-inch- thick, Type 302, satin-finished stainless steel.
 - 3. Material for Unfinished Spaces: Galvanized steel.
 - 4. Weatherproof plates: Cast metal, gasketed. For receptacles, provide spring loaded gasket doors.
- B. For receptacles with other than 120 volts, inscribe plate with voltage available.

2.6 HAND DRYERS

- A. Cover shall consist of min. 22 gauge galvanized stainless steel.
- B. Hand dryers shall be surface mounted and be ADA compliant.
- C. Top surface of dryer shall be sloped downwards towards front of unit.
- D. Motor shall be 8000 RPM at rated load.
- E. Motor and dual heating elements shall have internal resetting automatic thermal protection. The heating element shall be protected by an automatic, resetting circuit breaker mounted to the heating element frame.
- F. The dryer shall operate automatically from IR sensor when hands are placed in sensor zone and will shut off when hands are removed from sensor zone. The infra-red sensor shall be protected by a heavy duty polycarbonate lens frequently match-tinted to filter out ambient light.
- G. The entire hand dryer shall be U.L. listed.
- H. Dryer component parts shall be warranted to be free of defects in material and workmanship for a period of ten (10) years.
- I. 115V AC, 15 Amp, 1725 Watts
- J. Manufacturers:
 - 1. Bobrick Model No. B-7128 or equal.
 - 2. American Specialties, Inc.
 - 3. Excel Dryer

2.7 CARBON MONOXIDE DETECTORS

- A. Cover shall consist of min. 22 gauge galvanized stainless steel.

PART 3 - EXECUTION

3.1 INSTALLATION

- A. Install devices and assemblies plumb and secure.
- B. Install wall plates when painting is complete.
- C. Arrangement of Devices: Unless otherwise indicated, mount flush, with long dimension vertical, and grounding terminal of receptacles on top. Group adjacent switches under single, multigang wall plates.

Weedspport Addition to Maintenance Section and Roof Replacement, MP 304.2

- D. Protect devices and assemblies during painting.

3.2 IDENTIFICATION

- A. Comply with Division 26 Section "Electrical Identification."
 - 1. Switches: Where three or more switches are ganged, and elsewhere as indicated, identify each switch with approved legend engraved on wall plate.
 - 2. Receptacles: Identify panelboard and circuit number from which served. Use machine-printed, pressure-sensitive, abrasion-resistant label tape on face of plate and durable wire markers or tags within outlet boxes.

3.3 CONNECTIONS

- A. Connect wiring device grounding terminal to branch-circuit equipment grounding conductor.
- B. Tighten electrical connectors and terminals according to manufacturers published torque-tightening values. If manufacturers torque values are not indicated, use those specified in UL 486A and UL 486B.

3.4 FIELD QUALITY CONTROL

- A. Test wiring devices for proper polarity and ground continuity. Operate each device at least six times.
- B. Test GFCI operation with both local and remote fault simulations according to manufacturer's written instructions.
- C. Replace damaged or defective components.

3.5 CLEANING

- A. Internally clean devices, device outlet boxes, and enclosures. Replace stained or improperly painted wall plates or devices.

END OF SECTION 26 2726

SECTION 265100 - INTERIOR LIGHTING

PART 1 - GENERAL

1.1 RELATED DOCUMENTS

- A. Drawings and general provisions of the Contract, including General and Supplementary Conditions and Division 1 Specification Sections, apply to this Section.

1.2 SUMMARY

- A. This Section includes the following:
1. Interior lighting fixtures with LED lamps.
 2. Lighting fixtures mounted on exterior building surfaces.
 3. Exit signs.
 4. Accessories.
 5. Elementary School Cafetorium Theatrical Lighting, Controls, and support systems.
- B. Related Sections include the following:
1. Division 26 Section "Lighting Control Devices" for automatic control of lighting, including time switches, photoelectric relays, occupancy sensors and manual wall-box dimmers for LED fixtures.

1.3 DEFINITIONS

- A. CRI: Color rendering index.
- B. CU: Coefficient of utilization.
- C. Luminaire: Complete lighting fixture, including ballast housing if provided.
- D. LER: Luminaire efficiency rating, which is calculated according to NEMA LE 5. This value can be estimated from photometric data using the following formula:
1. LER is equal to the product of total rated lamp lumens times BF times luminaire efficiency, divided by input watts.
- E. RCR: Room cavity ratio.

1.4 SUBMITTALS

- A. Product Data: For each type of lighting fixture indicated, arranged in order of fixture designation. All lighting fixture types shall be submitted at the same time. Information on each fixture shall include data on features, accessories, and the following:
1. Physical description of fixture, including dimensions and verification of indicated parameters.
 2. Photometric ies files will be submitted for all fixture substitutions.
- B. Shop Drawings: Show details of nonstandard or custom fixtures. Indicate dimensions, weights, methods of field assembly, components, features, and accessories.
- C. Coordination Drawings: Reflected ceiling plan(s) and other details, drawn to scale, on which the following items are shown and coordinated with each other, based on input from installers of the items involved:
1. Lighting fixtures.

Weedsport Addition to Maintenance Section and Roof Replacement, MP 304.2

2. Suspended ceiling components.
 3. Structural members to which suspension systems for lighting fixtures will be attached.
 4. Other items in finished ceiling including the following:
 - a. Air outlets and inlets.
 - b. Speakers.
 - c. Sprinklers.
 - d. Smoke and fire detectors.
 - e. Occupancy sensors.
 - f. Access panels.
 5. Perimeter moldings.
- D. All submittals of NON SPECIFIED fixtures must include documentation, or they will be automatically rejected.
- E. Wiring Diagrams: Power, signal, and control wiring.
- F. Samples for Verification:
- a. For interior lighting fixtures designated for sample submission in the Interior Lighting Fixture Schedule.
 - 1) Lamps: Specified units installed.
 - 2) Ballast: 120-V models of specified ballast types.
 - 3) Accessories: Cords and plugs.
 - b. Substitution fixtures as requested by the engineer at time of submittal.
 - 1) Lamps: Specified units installed.
 - 2) Ballast: 120-V models of specified ballast types.
 - 3) Accessories: Cords and plugs.
 - c. Paint sample for light poles and associated luminaires.
 - d. Paint sample for decorative interior fixtures.
- G. Footcandle Point x Point room layouts for areas where substitutions have been offered.
- H. Product Certificates: For each type of driver for dimmer-controlled fixtures, signed by product manufacturer.
- I. Source quality-control test reports.
- J. Field quality-control test reports.
- K. Operation and Maintenance Data: For lighting equipment and fixtures to include in emergency, operation, and maintenance manuals. In addition to items specified in Division 1 Section Closeout Procedures include the following:
1. Catalog data for each fixture. Include the diffuser, driver, and LED data.
- L. Warranties: Special warranties specified in this Section.
- M. Submittals that fail to comply with the above requirements will automatically be rejected.
- N. It is the Contractor's responsibility to provide submittals in an organized and timely manner in order so as not to delay the project schedule and hamper the work of other trades.
- O. All submittals of NON SPECIFIED equipment and components will be reviewed. It is the submitting Contractor's responsibility to prove compliance and not the Architect/Engineer to prove non-compliance. The submitting Contractor will be charged the prevailing wage of the reviewing Engineer for all submittals requiring over one (1) hour to review that were not originally specified.

Weedsport Addition to Maintenance Section and Roof Replacement, MP 304.2

1.5 QUALITY ASSURANCE

- A. Testing Agency Qualifications: An independent agency, with the experience and capability to conduct the testing indicated, that is a member company of the InterNational Electrical Testing Association or is a nationally recognized testing laboratory (NRTL) as defined by OSHA in 29 CFR 1910.7, and that is acceptable to authorities having jurisdiction.
 - 1. Testing Agency's Field Supervisor: Person currently certified by the InterNational Electrical Testing Association or the National Institute for Certification in Engineering Technologies to supervise on-site testing specified in Part 3.
- B. Electrical Components, Devices, and Accessories: Listed and labeled as defined in NFPA 70, Article 100, by a testing agency acceptable to authorities having jurisdiction, and marked for intended use.
- C. Luminaire Photometric Data Testing Laboratory Qualifications: Provided by manufacturers' laboratories that are accredited under the National Volunteer Laboratory Accreditation Program for Energy Efficient Lighting Products.
- D. Comply with NFPA 70.
- E. NFPA 101 Compliance: Comply with visibility and luminance requirements for exit signs.

1.6 COORDINATION

- A. Coordinate layout and installation of lighting fixtures and suspension system with other construction that penetrates ceilings or is supported by them, including HVAC equipment, fire-suppression system, and partition assemblies.

PART 2 - PRODUCTS**2.1 MANUFACTURERS**

- A. Refer to Luminaire Schedule for specified products and manufacturers.
 - 1. Basis-of-Design Product: The design for each lighting fixture is based on the product named. Subject to compliance with requirements, provide either the named product or a product of equal performance, aesthetics, and construction.
 - 2. Non-specified products will be subject to possible request of point by point calculations and samples for comparison.

2.2 FIXTURES AND COMPONENTS, GENERAL

- A. Recessed Fixtures: Comply with NEMA LE 4 for ceiling compatibility for recessed fixtures.
- B. Metal Parts: Free of burrs and sharp corners and edges.
- C. Sheet Metal Components: Steel, unless otherwise indicated. Form and support to prevent warping and sagging.
- D. Doors, Frames, and Other Internal Access: Smooth operating, free of light leakage under operating conditions, and designed to permit relamping without use of tools. Designed to prevent doors, frames, lenses, diffusers, and other components from falling accidentally during relamping and when secured in operating position.
- E. Reflecting surfaces shall have minimum reflectance as follows, unless otherwise indicated:

Weedsport Addition to Maintenance Section and Roof Replacement, MP 304.2

1. White Surfaces: 85 percent.
 2. Specular Surfaces: 83 percent.
 3. Diffusing Specular Surfaces: 75 percent.
 4. Laminated Silver Metallized Film: 90 percent.
- F. Plastic Diffusers, Covers, and Globes:
1. Acrylic Lighting Diffusers: 100 percent virgin acrylic plastic. High resistance to yellowing and other changes due to aging, exposure to heat, and UV radiation.
 - a. Lens Thickness: At least 0.125 inch minimum unless different thickness is scheduled.
 - b. UV stabilized.
 2. Glass: Annealed crystal glass, unless otherwise indicated.
 3. All fixture lenses shall meet ASTM E-84, maximum smoke developed of 450 and ASTM E-635, maximum burn rate of 2.5 inches per minute.
- G. Electromagnetic-Interference Filters: A component of fixture assembly. Suppress conducted electromagnetic-interference as required by MIL-STD-461D. Fabricate lighting fixtures with one filter on each ballast indicated to require a filter.
- H. Finishes: Manufacturer's standard unless otherwise indicated.
1. Paint Finish: Applied over corrosion-resistant treatment or primer, free of defects.
 2. Metallic Finish: Corrosion resistant.

2.3 EXIT SIGNS

- A. General: Comply with UL 924; for sign colors and lettering size, comply with authorities having jurisdiction.
- B. Die-cast aluminum housing and canopy.
- C. Anodized aluminum housing with injection molded, high impact, clear acrylic panel edgelit.
- D. Universal snap-out directional arrows as required.
- E. Single and double face housing as required.
- F. Mounting components for top, wall (back), or end mounting as shown on documents.
- G. Internally Lighted Signs:
 1. Lamps for AC Operation: White, light-emitting diodes, 70,000 hours minimum of rated lamp life.
- H. Self-Powered Exit Signs (Battery Type): Integral automatic charger in a self-contained power pack.
 1. Battery: Sealed, maintenance-free, nickel-cadmium type with special warranty. Battery to deliver 90 minute minimum capacity to fixture.
 2. Charger: Fully automatic, solid-state type with sealed transfer relay.
 3. Operation: Relay automatically energizes lamp from battery when circuit voltage drops to 80 percent of nominal voltage or below. When normal voltage is restored, relay disconnects lamps from battery, and battery is automatically recharged and floated on charger.

2.4 EMERGENCY LIGHTING UNITS

- A. General Requirements for Emergency Lighting Units: Self-contained units.

Weedsport Addition to Maintenance Section and Roof Replacement, MP 304.2

- B. Minimum operating time of 90 minutes under full rated wattage.
- C. Self-diagnostic technology.
- D. Emergency Luminaires:
 - 1. Emergency Luminaires: As indicated on Luminaire Schedule with the following additional features:
 - a. Operating at nominal voltage of 120 V ac or 277 V ac : 6 V dc or 12 V dc.
 - b. Internal emergency power unit.
 - c. Rated for installation in damp locations, and for sealed and gasketed luminaires in wet locations.
 - d. UL 94 flame rating.
- E. Emergency Lighting Unit:
 - 1. Emergency Lighting Unit: As indicated on Luminaire Schedule.
 - 2. Operating at nominal voltage of 120 V ac or 277 V ac : 6 V dc or 12 V dc.
 - 3. Wall mount type with universal junction box adaptor.
 - 4. UV stable thermoplastic housing for interior dry locations.
 - 5. Aluminum housing for damp and wet location.
 - 6. Two lamp heads as indicated on plans.
 - 7. Internal emergency power unit.

2.5 LED SOURCES

- A. LEDs to meet LM-80 performance for 50,000 hours
- B. High efficiency driver
- C. Standard full range dimming on troffers.
- D. 5-year warranty of entire fixture including fixture construction and LED light engine driver.
- E. LED lamp minimum CRI of 82
- F. Fixture tested in accordance with IESNA LM-79.

2.8 FIXTURE SUPPORT COMPONENTS

- G. Comply with Division 26 Section "Hangers and Supports for Electrical Systems" for channel- and angle-iron supports and nonmetallic channel and angle supports.
- H. Single-Stem Hangers: 1/2-inch steel tubing with swivel ball fittings and ceiling canopy. Finish same as fixture.
- I. Twin-Stem Hangers: Two, 1/2-inch steel tubes with single canopy designed to mount a single fixture. Finish same as fixture.
- J. Wires: ASTM A 641/A 641M, Class 3, soft temper, zinc-coated, [12 gage].
- K. Wires For Humid Spaces: ASTM A 580/A 580M, Composition 302 or 304, annealed stainless steel, 12 gage.
- L. Rod Hangers: 3/16-inch- minimum diameter, cadmium-plated, threaded steel rod.
- M. Hook Hangers: Integrated assembly matched to fixture and line voltage and equipped with threaded attachment, cord, and locking-type plug.

Weedsport Addition to Maintenance Section and Roof Replacement, MP 304.2

- N. Aircraft Cable Support: Use cable, anchorages, and intermediate supports recommended by fixture manufacturer.

2.9 SOURCE QUALITY CONTROL

- A. Provide services of a qualified, independent testing and inspecting agency to factory test fixtures with ballasts and lamps; certify results for electrical ratings and photometric data.
- B. Factory test fixtures with ballasts and lamps; certify results for electrical ratings and photometric data.

2.10 ELEMENTARY SCHOOL CAFETORIUM THEATRICAL LIGHTING, CONTROLS, AND SUPPORT SYSTEMS

- A. System as shown on drawing ES/E300 consists of an architectural touchscreen control station, full color mixing Fresnel LED fixtures, 30' linear pipe batten, fixture clamps, and associated DMX cabling.
- B. Architectural Control Station: Fully integrated lighting management system designed to integrate with all Philips dimming systems, low voltage switching cabinets, and LED fixtures.
1. Next generation scalable from a single room to a multi-building campus.
 2. Distributed intelligence – no central processor required.
 3. Provided with Full color 7-inch touchscreen panel.
 4. Simple computer-based set up and configuration with Vision.net 4.5 designer software.
 5. Intuitive automated luminaire and LED fixture interface.
 6. Customizable fixture library to create your own fixtures.
 7. Occupancy sensors and photocells available.
 8. Designers can easily create rooms, room combinations, and easily define stations and buttons.
 9. Simple graphical set up and configuration system for original set up and updates.
 10. 127 channels per room.
 11. Unlimited dimmers per room with patching and DMX512 snapshot support.
 12. Astronomical time-clock and calendar-based events.
 13. Manufacturer: Philips Strand Lighting
 14. Model #Vision.net 4.5
- C. LED Theatrical fixtures: Full Color LED (RGBAL) Fresnel lighting fixtures
1. Soft, even field of light.
 2. Smooth, motorized zoom from 30° to 85°.
 3. Color Temperature Presets from 2800 K to 6500 K.
 4. 16-bit dimming of master dimmer and individual colors.
 5. Easy to use on board control of color, zoom, and dimming.
 6. Virtual color wheel with color matched to popular gel colors.
 7. Adjustable PWM (Pulse Width Modulation) to avoid flickering on camera.
 8. RDM (Remote Device Management) for added flexibility.
 9. Optical: Light Source: 89 LEDs (18 red, 18 green, 16 blue, 16 amber, 21 lime) 3 W, (1.13 A), 3698 K, 50,000 hours life expectancy
 10. Construction/Physical: Dimensions: 22.41 x 12.59 x 10.82 in; Weight: 19 lb; Exterior Color: Black; Housing Material: Aluminum alloy, Aluminum die-cast.
 11. Control: Control Protocol: DMX, RDM; DMX Channels: 3, 5, 7, 11, 13, 14 or 17; Modes/Personalities: 8 personalities (3, 5, 7, 11, 13, 14, 17, HSV)

Weedsport Addition to Maintenance Section and Roof Replacement, MP 304.2

12. Connections: Power connection: Edison (Local) plug to Neutrik powerCON
 13. Electrical: Power and current: 260w, 2.15a @ 120v, 60 Hz.
 14. Certifications/Qualifications: CE, MET, IP Rating: IP20, dry location.
 15. Fixture Manufacturer: Chauvet, Model Ovation F-915FC
 16. Neutrik powerCON power cord
 17. Professional Clamps: CTC-50HC, CTC-50HCN
 18. Neutrik powerCON cables
 19. Quantity: Provide a total of (7) fixtures with associated clamps and cables.
- D. Wiring
1. Provide 120v branch circuit wiring to fixtures and control station.
 2. Provide DMX wiring between control station and fixtures.
 3. Daisy chain DMX wiring from fixture to fixture.
- E. Lighting Pipe Batten System
1. Standard Theatrical Pipe - Schedule 40 black iron pipe batten.
 2. 1.5" inside diameter, 2" outside diameter, 30 feet in length.
 3. Supported on not less than 6-foot mounting centers.
 4. Electrical contractor shall employ a structural engineer for final, certified structural support design.
 5. Coordinate installation of batten system with general contractor. Pipe to be mounted from bulkhead in cafetorium.
 6. One clamp per fixture.
 7. One safety cable per fixture.

PART 3 - EXECUTION

3.1 INSTALLATION

- A. Fixtures: Set level, plumb, and square with ceilings and walls.
- B. Support for Fixtures in or on Grid-Type Suspended Ceilings: Complete all of the following:
1. Install a minimum of two support system rods or wires for each fixture. Locate not more than 6 inches from fixture corners. Wire or rod shall have breaking strength of the weight of fixture at a safety factor of 3 and be supported by building steel (not ceiling system grid supports).
 2. Support Clips: Fasten to fixtures and to ceiling grid members at or near each fixture corner with clips that are UL listed for the application.
 3. Fixtures of Sizes Less Than Ceiling Grid: Install as indicated on reflected ceiling plans or center in acoustical panel, and support fixtures independently with at least two 3/4-inch metal channels spanning and secured to ceiling tees.
- C. Suspended Fixture Support: As follows:
1. Pendants and Rods: Where longer than 48 inches, brace to limit swinging.
 2. Stem-Mounted, Single-Unit Fixtures: Suspend with twin-stem hangers.
 3. Continuous Rows: Use tubing or stem for wiring at one point and tubing or rod for suspension for each unit length of fixture chassis, including one at each end.
 4. Continuous Rows: Suspend from cable.
- D. Adjust aimable fixtures to provide required light intensities.

Weedsport Addition to Maintenance Section and Roof Replacement, MP 304.2

3.2 CONNECTIONS

- A. Tighten electrical connectors and terminals according to manufacturer's published torque-tightening values. If manufacturer's torque values are not indicated, use those specified in UL 486A and UL 486B.

3.3 FIELD QUALITY CONTROL

- A. Inspect each installed fixture for damage. Replace damaged fixtures and components.
- B. Verify normal operation of each fixture after installation.
- C. Test for Emergency Lighting: Interrupt power supply to demonstrate proper operation. Verify normal transfer to battery power source and retransfer to normal.
- D. Prepare a written report of tests, inspections, observations, and verifications indicating and interpreting results. If adjustments are made to lighting system, retest to demonstrate compliance with standards.
- E. Corroded Fixtures: During warranty period, replace fixtures that show any signs of corrosion.

END OF SECTION 265100

ITEM 627.0031 25**EARTHWORK****1. DESCRIPTION:**

- 1.01 Furnish all labor, materials, equipment and services necessary to complete the work as indicated on the Contract Plans and the Specification Sections listed below
- 1.04 All work shall conform to the requirements specified in Part 1 – General, of the Sections listed.

2. MATERIALS:

- 2.01 The materials shall be as specified in Part 2 – Products, of the Sections listed.

3. CONSTRUCTION DETAILS:

- 3.01 The construction details shall be as specified on Part 3 – Execution, if the Sections listed.

4. METHOD OF MEASUREMENT:

- 4.01 This item shall be measured for payment on a lump sum basis for the work completed in accordance with the Contract Documents and as directed by the Engineer.

5. BASIS OF PAYMENT:

- 5.01 Payment for this item shall be made at the lump sum bid price bid. The lump sum price bid shall include cost of furnishing all labor, material, equipment and appliances necessary to complete the work as indicated on the Contract Plans and as specified herein in the Sections listed.
- 5.02 Detailed Estimate:
 - A. Before the first certificate of payment is issued for the work under this item, submit a detailed estimate of quantities and prices for all materials, labor, and other items included under this item, which shall aggregate the contract lump sum price bid for this item. Prepare the detailed estimate in the same sequence as the Sections listed.
 - B. The detailed estimate shall be supported by such evidence, including certified copies of subcontracts, as the Engineer may require.
 - C. The detailed estimate must be approved by the Engineer who may revise it as, in his/her reasonable judgment, is necessary to make the various item conform to their true values. The value of each certificate of payment will be based on the approved detailed estimate.
- 5.03 Monthly payments will be made for this item in proportion to the total amount of work completed.

ITEM 627.0031 25**EARTHWORK****1. SPECIFICATION SUMMARY**

1.01 This Item includes the following specifications:

- A. Section 311000 SITE CLEARING
- B. Section 312000 EARTH MOVING
- C. Section 312319 DEWATERING
- D. Section 315000 EXCAVATION SUPPORT AND PROTECTION

1.02 This item shall include, but not be limited to, the following:

- A. Site work needed for the construction of the building's addition, including earthwork and preparation

SECTION 311000 - SITE CLEARING

PART 1 - GENERAL

1.1 SUMMARY

- A. Section Includes:
1. Protecting existing vegetation to remain.
 2. Removing existing vegetation.
 3. Clearing and grubbing.
 4. Stripping and stockpiling topsoil.
 5. Stripping and stockpiling rock.
 6. Removing above- and below-grade site improvements.
 7. Disconnecting, capping or sealing, and removing site utilities abandoning site utilities in place.
 8. Temporary erosion and sedimentation control.

1.2 DEFINITIONS

- A. Subsoil: Soil beneath the level of subgrade; soil beneath the topsoil layers of a naturally occurring soil profile, typified by less than 1 percent organic matter and few soil organisms.
- B. Surface Soil: Soil that is present at the top layer of the existing soil profile. In undisturbed areas, surface soil is typically called "topsoil," but in disturbed areas such as urban environments, the surface soil can be subsoil.
- C. Topsoil: Top layer of the soil profile consisting of existing native surface topsoil or existing in-place surface soil; the zone where plant roots grow.
- D. Topsoil: Top layer of the soil profile consisting of existing native surface topsoil or existing in-place surface soil; the zone where plant roots grow. Its appearance is generally friable, pervious, and black or a darker shade of brown, gray, or red than underlying subsoil; reasonably free of subsoil, clay lumps, gravel, and other objects larger than **2 inches** in diameter; and free of weeds, roots, toxic materials, or other nonsoil materials.
- E. Plant-Protection Zone: Area surrounding individual trees, groups of trees, shrubs, or other vegetation to be protected during construction and indicated on Drawings.
- F. Tree-Protection Zone: Area surrounding individual trees or groups of trees to be protected during construction and as indicated on Drawings.
- G. Vegetation: Trees, shrubs, groundcovers, grass, and other plants.

1.3 MATERIAL OWNERSHIP

- A. Except for materials indicated to be stockpiled or otherwise remain Owner's property, cleared materials shall become Contractor's property and shall be removed from Project site.

1.4 INFORMATIONAL SUBMITTALS

- A. Existing Conditions: Documentation of existing trees and plantings, adjoining construction, and site improvements that establishes preconstruction conditions that might be misconstrued as damage caused by site clearing.
1. Use sufficiently detailed photographs or video recordings.

Weedsport Addition to Maintenance Section and Roof Replacement, MP 304.2

2. Include plans and notations to indicate specific wounds and damage conditions of each tree or other plant designated to remain.
- B. Topsoil stripping and stockpiling program.
 - C. Rock stockpiling program.
 - D. Record Drawings: Identifying and accurately showing locations of capped utilities and other subsurface structural, electrical, and mechanical conditions.
 - E. Burning: Documentation of compliance with burning requirements and permitting of authorities having jurisdiction. Identify location(s) and conditions under which burning will be performed.

1.5 QUALITY ASSURANCE

- A. Topsoil Stripping and Stockpiling Program: Prepare a written program to systematically demonstrate the ability of personnel to properly follow procedures and handle materials and equipment during the Work. Include dimensioned diagrams for placement and protection of stockpiles.
- B. Rock Stockpiling Program: Prepare a written program to systematically demonstrate the ability of personnel to properly follow procedures and handle materials and equipment during the Work. Include dimensioned diagrams for placement and protection of stockpiles.

1.6 FIELD CONDITIONS

- A. Traffic: Minimize interference with adjoining roads, streets, walks, and other adjacent occupied or used facilities during site-clearing operations.
 1. Do not close or obstruct streets, walks, or other adjacent occupied or used facilities without permission from Owner and authorities having jurisdiction.
 2. Provide alternate routes around closed or obstructed trafficways if required by Owner or authorities having jurisdiction.
- B. Improvements on Adjoining Property: Authority for performing site clearing indicated on property adjoining Owner's property will be obtained by Owner before award of Contract.
 1. Do not proceed with work on adjoining property until directed by Architect.
- C. Salvageable Improvements: Carefully remove items indicated to be salvaged and store on Owner's premises.
- D. Utility Locator Service: Notify **Call Before You Dig or Dig Safe System** for area where Project is located before site clearing.
- E. Do not commence site clearing operations until temporary erosion- and sedimentation-control measures are in place.
- F. Soil Stripping, Handling, and Stockpiling: Perform only when the soil is dry or slightly moist.

PART 2 - PRODUCTS**2.1 MATERIALS**

- A. Satisfactory Soil Material: Requirements for satisfactory soil material are specified in Section 312000 "Earth Moving."
 1. Obtain approved borrow soil material off-site when satisfactory soil material is not available on-site.

PART 3 - EXECUTION

3.1 PREPARATION

- A. Protect and maintain benchmarks and survey control points from disturbance during construction.
- B. Protect trees, shrubs, and other vegetation to remain or to be relocated according to requirements in Section 015000 "Temporary Facilities and Controls"
- C. Protect existing site improvements to remain from damage during construction.
 - 1. Restore damaged improvements to their original condition, as acceptable to Owner.

3.2 TEMPORARY EROSION AND SEDIMENTATION CONTROL

- A. Provide temporary erosion- and sedimentation-control measures to prevent soil erosion and discharge of soil-bearing water runoff or airborne dust to adjacent properties and walkways, according to erosion- and sedimentation-control Drawings and requirements of authorities having jurisdiction.
- B. Verify that flows of water redirected from construction areas or generated by construction activity do not enter or cross protection zones.
- C. Inspect, maintain, and repair erosion- and sedimentation-control measures during construction until permanent vegetation has been established.
- D. Remove erosion and sedimentation controls, and restore and stabilize areas disturbed during removal.

3.3 TREE AND PLANT PROTECTION

- A. Protect trees and plants remaining on-site.
- B. Repair or replace trees, shrubs, and other vegetation indicated to remain or be relocated that are damaged by construction operations.

3.4 EXISTING UTILITIES

- A. Owner will arrange for disconnecting and sealing indicated utilities that serve existing structures before site clearing, when requested by Contractor.
 - 1. Verify that utilities have been disconnected and capped before proceeding with site clearing.
- B. Locate, identify, disconnect, and seal or cap utilities indicated to be removed **or abandoned in place**.
 - 1. Arrange with utility companies to shut off indicated utilities.
 - 2. Owner will arrange to shut off indicated utilities when requested by Contractor.
- C. Locate, identify, and disconnect utilities indicated to be abandoned in place.
- D. Interrupting Existing Utilities: Do not interrupt utilities serving facilities occupied by Owner or others, unless permitted under the following conditions and then only after arranging to provide temporary utility services according to requirements indicated:
 - 1. Notify Architect not less than **two** days in advance of proposed utility interruptions.
 - 2. Do not proceed with utility interruptions without Architect's written permission.
- E. Excavate for and remove underground utilities indicated to be removed.

Weedsport Addition to Maintenance Section and Roof Replacement, MP 304.2

- F. Removal of underground utilities is included in earthwork sections; in applicable fire suppression, plumbing, HVAC, electrical, communications, electronic safety and security, and utilities sections; and in Section 024119 "Selective Demolition."

3.5 CLEARING AND GRUBBING

- A. Remove obstructions, trees, shrubs, and other vegetation to permit installation of new construction.
- B. Fill depressions caused by clearing and grubbing operations with satisfactory soil material unless further excavation or earthwork is indicated.
 - 1. Place fill material in horizontal layers not exceeding a loose depth of 8 inches, and compact each layer to a density equal to adjacent original ground.

3.6 TOPSOIL STRIPPING

- A. Remove sod and grass before stripping topsoil.
- B. Strip topsoil to depth indicated on Drawings or not less than 6 inches in a manner to prevent intermingling with underlying subsoil or other waste materials.
 - 1. Remove subsoil and nonsoil materials from topsoil, including clay lumps, gravel, and other objects larger than 2 inches in diameter; trash, debris, weeds, roots, and other waste materials.
- C. Stockpile topsoil away from edge of excavations without intermixing with subsoil or other materials. Grade and shape stockpiles to drain surface water. Cover to prevent windblown dust and erosion by water.
 - 1. Do not stockpile topsoil within protection zones.
 - 2. Dispose of surplus topsoil. Surplus topsoil is that which exceeds quantity indicated to be stockpiled or reused.
 - 3. Stockpile surplus topsoil to allow for respreading deeper topsoil.

3.7 SITE IMPROVEMENTS

- A. Remove existing above- and below-grade improvements as indicated and necessary to facilitate new construction.
- B. Remove slabs, paving, curbs, gutters, and aggregate base as indicated.
 - 1. Unless existing full-depth joints coincide with line of demolition, neatly saw-cut along line of existing pavement to remain before removing adjacent existing pavement. Saw-cut faces vertically.
 - 2. Paint cut ends of steel reinforcement in concrete to remain with two coats of antirust coating, following coating manufacturer's written instructions. Keep paint off surfaces that will remain exposed.

3.8 DISPOSAL OF SURPLUS AND WASTE MATERIALS

- A. Remove surplus soil material, unsuitable topsoil, obstructions, demolished materials, and waste materials including trash and debris, and legally dispose of them off Owner's property.
- B. Burning tree, shrub, and other vegetation waste is permitted according to burning requirements and permitting of authorities having jurisdiction. Control such burning to produce the least smoke or air pollutants and minimum annoyance to surrounding properties. Burning of other waste and debris is prohibited.

Weedsport Addition to Maintenance Section and Roof Replacement, MP 304.2

- C. Separate recyclable materials produced during site clearing from other nonrecyclable materials. Store or stockpile without intermixing with other materials, and transport them to recycling facilities. Do not interfere with other Project work.

END OF SECTION 311000

SECTION 312000 - EARTH MOVING

PART 1 - GENERAL

1.1 SUMMARY

- A. Section Includes:
1. Preparing subgrades for slabs-on-grade, walks, pavements, turf and grasses.
 2. Mass excavations
 3. Excavating and backfilling for buildings and structures.
 4. Subbase course for concrete and asphalt paving.
 5. Subsurface drainage backfill for walls and trenches.
 6. Excavating and backfilling trenches for utilities and pits for buried utility structures.

1.2 ACTION SUBMITTALS

- A. Product Data: For each type of the following manufactured products required:
1. Geotextiles.
 2. Controlled low-strength material, including design mixture.
 3. Warning tapes.

1.3 INFORMATIONAL SUBMITTALS

- A. Material Test Reports: For each on-site and borrow soil material proposed for fill and backfill as follows:
1. Classification according to ASTM D 2487.
 2. Laboratory compaction curve according to ASTM D 1557.
- B. Pre-excavation Photographs or Videotape: Show existing conditions of adjoining construction and site improvements, including finish surfaces that might be misconstrued as damage caused by earth moving operations. Submit before earth moving begins.
- C. Improvements on Adjoining Property: Authority for performing earth moving indicated on property adjoining Owner's property will be obtained by Owner before award of Contract.
1. Do not proceed with work on any adjoining property until directed by Owner's Representative.

PART 2 - PRODUCTS

2.1 SOIL MATERIALS

- A. General: Provide borrow soil materials when sufficient satisfactory soil materials are not available from excavations.
- B. Satisfactory Soils: Soil Classification Groups GW, GP, GM, SW, SP, and SM according to ASTM D 2487, or a combination of these groups; free of rock or gravel larger than 3 inches in any dimension, debris, waste, frozen materials, vegetation, and other deleterious matter.
- C. Unsatisfactory Soils: Soil Classification Groups GC, SC, CL, ML, OL, CH, MH, OH, and PT according to ASTM D 2487, or a combination of these groups.
1. Unsatisfactory soils also include satisfactory soils not maintained within 2 percent of optimum moisture content at time of compaction.

Weedsport Addition to Maintenance Section and Roof Replacement, MP 304.2

- D. Subbase Material: Material shall be clean, sound, consisting of either gravel, stone, slag, and sands meeting the requirements of the local State Department of Transportation /Agency (State DOT) or local highway Specifications. Stone sizing and type as specified on Contract Drawings.
- E. Crushed Stone Fill - Material shall be clean, sound, washed or unwashed, crushed stone of uniform quality. It shall be a 50-50 mixture of NYSDOT size designation #1 and #2 stone as per NYSDOT Standard Specifications (703-02).
- F. Select Granular Fill: Material shall meet the requirements for select granular fill Item 203.07 as defined in the New York State Department of Transportation "Standard Specifications".
- G. Bedding Course: Naturally or artificially graded mixture of natural or crushed gravel, crushed stone, and natural or crushed sand; ASTM D 2940; except with 100 percent passing a 1-inch sieve and not more than 5 percent passing a No. 200 sieve.
- H. Drainage Course: Material shall meet the requirements of Item 605.0901, Type 1, or a 50-50 mixture of Type I and Type II (605.1001) as defined in the New York State Department of Transportation "Standard Specification".
- I. Filter Material: Narrowly graded mixture of natural or crushed gravel, or crushed stone and natural sand; ASTM D 448; coarse-aggregate grading Size 67; with 100 percent passing a 1-inch sieve and 0 to 5 percent passing a No. 4 sieve.
- J. Sand: ASTM C 33; fine aggregate.
- K. Stone Filling (Riprap) – meeting New York State Department of Transportation "Standard Specification" Section 620.0 . Size as indicated on the drawings.

2.2 GEOTEXTILES

- A. Subsurface Drainage Geotextile: Nonwoven needle-punched geotextile, manufactured for subsurface drainage applications, made from polyolefin or polyesters; with elongation greater than 50 percent; complying with AASHTO M 288 and the following, measured per test methods referenced:
 - 1. Grab Tensile Strength: >157 lbf; ASTM D 4632.
 - 2. Sewn Seam Strength: >142 lbf; ASTM D 4632.
 - 3. Tear Strength: >56 lbf; ASTM D 4533.
 - 4. Puncture Strength: >56 lbf; ASTM D 4833.
 - 5. Apparent Opening Size: **No. 40** sieve, maximum; ASTM D 4751.
 - 6. Permittivity: 0.5 per second, minimum; ASTM D 4491.
 - 7. UV Stability: 50 percent after 500 hours' exposure; ASTM D 4355.
- B. Separation Geotextile: Woven geotextile fabric, manufactured for separation applications, made from polyolefin or polyesters; with elongation less than 50 percent; complying with AASHTO M 288 and the following, measured per test methods referenced:
 - 1. Grab Tensile Strength: >**247 lbf**; ASTM D 4632.
 - 2. Sewn Seam Strength: >**222 lbf**; ASTM D 4632.
 - 3. Tear Strength: >**90 lbf**; ASTM D 4533.
 - 4. Puncture Strength: >**90 lbf**; ASTM D 4833.
 - 5. Apparent Opening Size: **No. 60** sieve, maximum; ASTM D 4751.
 - 6. Permittivity: 0.02 per second, minimum; ASTM D 4491.
 - 7. UV Stability: 50 percent after 500 hours' exposure; ASTM D 4355.

Weedsport Addition to Maintenance Section and Roof Replacement, MP 304.2

2.3 CONTROLLED LOW-STRENGTH MATERIAL

- A. Controlled Low-Strength Material: Self-compacting, flowable concrete material produced from the following:
1. Portland Cement: ASTM C 150, Type I or Type II.
 2. Fly Ash: ASTM C 618, Class C or F.
 3. Normal-Weight Aggregate: ASTM C 33, 3/8-inch nominal maximum aggregate size.
 4. Foaming Agent: ASTM C 869.
 5. Water: ASTM C 94/C 94M.
 6. Air-Entraining Admixture: ASTM C 260.

2.4 ACCESSORIES

- A. Detectable Warning Tape: Acid- and alkali-resistant, polyethylene film warning tape manufactured for marking and identifying underground utilities, a minimum of 6 inches wide and 4 mils thick, continuously inscribed with a description of the utility, with metallic core encased in a protective jacket for corrosion protection, detectable by metal detector when tape is buried up to 30 inches deep; colored as follows:
1. Red: Electric.
 2. Yellow: Gas, oil, steam, and dangerous materials.
 3. Orange: Telephone and other communications.
 4. Blue: Water systems.
 5. Green: Sewer systems.

PART 3 - EXECUTION**3.1 PREPARATION**

- A. Protect structures, utilities, sidewalks, pavements, and other facilities from damage caused by settlement, lateral movement, undermining, washout, and other hazards created by earth moving operations.
- B. Protect and maintain erosion and sedimentation controls during earth moving operations.
- C. Protect subgrades and foundation soils from freezing temperatures and frost. Remove temporary protection before placing subsequent materials.

3.2 DEWATERING

- A. Prevent surface water and ground water from entering excavations and trenches from ponding on prepared subgrades, and from flooding work areas, Project site and surrounding areas.
- B. Protect subgrades from softening, undermining, washout, and damage by rain or water accumulation.
 1. Reroute surface water runoff away from excavated areas. Do not allow water to accumulate in excavations. Do not use excavated trenches as temporary drainage ditches.
- C. All water removed from the trenches or excavations by pumping, bailing, siphoning, well-points, or other means shall be disposed of in such a manner that avoids damage to the work, work of other Contractors, surface and ground water, persons or property. Unless otherwise permitted by the Engineer, groundwater encountered within the limits of excavation shall be depressed to an elevation not less than 12 inches below the bottom thereof before pipe laying or concreting is started, and shall be so maintained until concrete and joint material have attained adequate strength.

Weedsport Addition to Maintenance Section and Roof Replacement, MP 304.2

- D. The Contractor shall not discharge water from dewatering operations directly into any line or intermittent stream, channel, wetlands or surface water. The Contractor shall not discharge water from dewatering operations directly into the storm or sanitary sewer system without prior approval of the Engineer. If in the opinion of the Engineer, water from dewatering operations contains unacceptable amounts of sediment, the water shall be treated by filtration, sedimentation basins, or other methods to reduce the amount of sediment contained in the water to allowable levels, as acceptable to the Engineer, prior to disposal.
- E. Upon completion of the section wherein the operations have been performed, the Contractor shall remove from the catch basins, ditches, and swales, all mud, silt, debris, and other accumulations discharged to these various locations. The Contractor is responsible for leaving them in a condition similar to that which existed prior to his operations. Proper control measures shall be employed, to minimize siltation and erosion in and adjacent to the area of work.

3.3 EXCAVATION, GENERAL

- A. Unclassified Excavation: Excavate to subgrade elevations regardless of the character of surface and subsurface conditions encountered. Unclassified excavated materials may include rock, soil materials, and obstructions. No changes in the Contract Sum or the Contract Time will be authorized for rock excavation or removal of obstructions.
1. If excavated materials intended for fill and backfill include unsatisfactory soil materials and rock, replace with satisfactory soil materials.
 2. Rock excavation includes removal and disposal of rock. Remove rock to lines and subgrade elevations indicated to permit installation of permanent construction.

3.4 EXCAVATION FOR STRUCTURES

- A. Excavate to indicated elevations and dimensions within a tolerance of plus or minus **1 inch**. If applicable, extend excavations a sufficient distance from structures for safely placing and removing concrete formwork, for installing services and other construction, and for inspections.
1. Excavations for Footings and Foundations: Do not disturb bottom of excavation. Excavate by hand to final grade just before placing concrete reinforcement. Trim bottoms to required lines and grades to leave solid base to receive other work.

3.5 EXCAVATION FOR WALKS AND PAVEMENTS

- A. Excavate surfaces under walks and pavements to indicated lines, cross sections, elevations, and subgrades.

3.6 EXCAVATION FOR UTILITY TRENCHES

- A. Excavate trenches to indicated gradients, lines, depths, and elevations.
1. Beyond building perimeter, excavate trenches to allow installation of top of pipe below frost line as required.
- B. Excavate trenches to uniform widths to provide the following clearance on each side of pipe or conduit. Excavate trench walls vertically from trench bottom to **12 inches** higher than top of pipe or conduit unless otherwise indicated.
- C. Trench Bottoms: Excavate and shape trench bottoms to provide uniform bearing and support of pipes and conduit. Shape subgrade to provide continuous support for bells, joints, and barrels of pipes and for joints, fittings, and bodies of conduits. Remove projecting stones and sharp objects along trench subgrade.

Weedsport Addition to Maintenance Section and Roof Replacement, MP 304.2

1. For pipes and conduit less than **6 inches** in nominal diameter, hand-excavate trench bottoms and support pipe and conduit on an undisturbed subgrade.
 2. For pipes and conduit **6 inches** or larger in nominal diameter, shape bottom of trench to support bottom 90 degrees of pipe or conduit circumference. Fill depressions with tamped sand backfill.
 3. For flat-bottomed, multiple-duct conduit units, hand-excavate trench bottoms and support conduit on an undisturbed subgrade.
 4. Excavate trenches **6 inches** deeper than elevation required in rock or other unyielding bearing material to allow for bedding course.
- D. Trench Bottoms: Excavate trenches **4 inches** deeper than bottom of pipe and conduit elevations to allow for bedding course. Hand-excavate deeper for bells of pipe.
1. Excavate trenches **6 inches** deeper than elevation required in rock or other unyielding bearing material to allow for bedding course.
- E. Trenches in Tree- and Plant-Protection Zones:
1. Hand-excavate to indicated lines, cross sections, elevations, and subgrades. Use narrow-tine spading forks to comb soil and expose roots. Do not break, tear, or chop exposed roots. Do not use mechanical equipment that rips, tears, or pulls roots.
 2. Do not cut main lateral roots or taproots; cut only smaller roots that interfere with installation of utilities.

3.7 SUBGRADE INSPECTION

- A. Notify Owner's Representative when excavations have reached required subgrade.
- B. If Owner's Representative determines that unsatisfactory soil is present, continue excavation and replace with compacted backfill or fill material as directed.
- C. Proof-roll subgrade below the building slabs and pavements with a pneumatic-tired and loaded 10-wheel, tandem-axle dump truck weighing not less than **15 tons** to identify soft pockets and areas of excess yielding. Do not proof-roll wet or saturated subgrades.
1. Completely proof-roll subgrade in one direction. Limit vehicle speed to **3 mph**.
 2. Excavate soft spots, unsatisfactory soils, and areas of excessive pumping or rutting, as determined by Owner's Representative. Place No. 3/No. 4 size stone to stabilize subgrades as directed by Engineer or onsite geotechnical engineer and approved by Owner's Representative. Replace excavated soil with compacted backfill or fill as directed.
- D. Authorized additional excavation and replacement material will be paid for per Contract provisions for unit prices or changes in the Work as applicable.
- E. Reconstruct subgrades damaged by freezing temperatures, frost, rain, accumulated water, or construction activities, as directed by Owner's Representative, without additional compensation.

3.8 UNAUTHORIZED EXCAVATION

- A. Fill unauthorized excavation under foundations or wall footings by extending bottom elevation of concrete foundation or footing to excavation bottom, without altering top elevation. Lean concrete fill, with 28-day compressive strength of **2,500 psi**, may be used when approved by Owner's Representative.
1. Fill unauthorized excavations under other construction, pipe, or conduit as directed by Owner's Representative.

Weedsport Addition to Maintenance Section and Roof Replacement, MP 304.2

3.9 STORAGE OF SOIL MATERIALS

- A. Stockpile borrow soil materials and excavated satisfactory soil materials without intermixing. Place, grade, and shape stockpiles to drain surface water. Cover to prevent windblown dust.
 - 1. Stockpile soil materials away from edge of excavations. Do not store within drip line of remaining trees.

3.10 BACKFILL

- A. Place and compact backfill in excavations promptly, but not before completing the following:
 - 1. Construction below finish grade including, where applicable, subdrainage, damp proofing, waterproofing, and perimeter insulation.
 - 2. Surveying locations of underground utilities for Record Documents.
 - 3. Testing and inspecting underground utilities.
 - 4. Removing concrete formwork.
 - 5. Removing trash and debris.
 - 6. Removing temporary shoring and bracing, and sheeting.
 - 7. Installing permanent or temporary horizontal bracing on horizontally supported walls.
- B. Place backfill on subgrades free of mud, frost, snow, or ice.

3.11 UTILITY TRENCH BACKFILL

- A. Place backfill on subgrades free of mud, frost, snow, or ice.
- B. Place and compact bedding course on trench bottoms and where indicated. Shape bedding course to provide continuous support for bells, joints, and barrels of pipes and for joints, fittings, and bodies of conduits.
- C. Trenches under Footings: Backfill trenches excavated under footings and within **18 inches** of bottom of footings with satisfactory soil; fill with concrete to elevation of bottom of footings.
- D. Backfill voids with satisfactory soil while removing shoring and bracing.
- E. Controlled Low-Strength Material: Place initial backfill of controlled low-strength material to a height of **12 inches** over the pipe or conduit. Coordinate backfilling with utilities testing.
- F. Place and compact final backfill of satisfactory soil to final subgrade elevation.
- G. Controlled Low-Strength Material: Place final backfill of controlled low-strength material to final subgrade elevation.

3.12 SOIL FILL

- A. Plow, scarify, bench, or break up sloped surfaces steeper than 1 vertical to 4 horizontal so fill material will bond with existing material.
- B. Place and compact fill material in layers to required elevations as follows:
 - 1. Under grass and planted areas, use satisfactory soil material.
 - 2. Under walks and pavements, use satisfactory soil material.
 - 3. Under steps and ramps, use engineered fill.
 - 4. Under building slabs, use engineered fill.
 - 5. Under footings and foundations, use engineered fill.
- C. Place soil fill on subgrades free of mud, frost, snow, or ice.

Weedsport Addition to Maintenance Section and Roof Replacement, MP 304.2

3.13 SOIL MOISTURE CONTROL

- A. Uniformly moisten or aerate subgrade and each subsequent fill or backfill soil layer before compaction to within 2 percent of optimum moisture content.
1. Do not place backfill or fill soil material on surfaces that are muddy, frozen, or contain frost or ice.
 2. Remove and replace, or scarify and air dry, otherwise satisfactory soil material that exceeds optimum moisture content by 2 percent and is too wet to compact to specified dry unit weight.

3.14 COMPACTION OF SOIL BACKFILLS AND FILLS

- A. Place backfill and fill soil materials in layers not more than **8 inches** in loose depth for material compacted by heavy compaction equipment, and not more than **4 inches** in loose depth for material compacted by hand-operated tampers.
- B. Place backfill and fill soil materials evenly on all sides of structures to required elevations, and uniformly along the full length of each structure.
- C. Compact soil materials to not less than the following percentages of maximum dry unit weight per ASTM D 1557:
1. Under structures, building slabs, steps, and pavements, scarify and recompact top **12 inches** of existing subgrade and each layer of backfill or fill soil material at 95 percent.
 2. Under walkways, scarify and recompact top **6 inches** below subgrade and compact each layer of backfill or fill soil material at 95 percent.
 3. Under turf or unpaved areas, scarify and recompact top **6 inches** below subgrade and compact each layer of backfill or fill soil material at 90 percent.
 4. For utility trenches, compact each layer of initial and final backfill soil material at 90 percent for non-traffic areas and 95% for traffic areas.

3.15 GRADING

- A. General: Uniformly grade areas to a smooth surface, free of irregular surface changes. Comply with compaction requirements and grade to cross sections, lines, and elevations indicated.
1. Provide a smooth transition between adjacent existing grades and new grades.
 2. Cut out soft spots, fill low spots, and trim high spots to comply with required surface tolerances.
- B. Site Rough Grading: Slope grades to direct water away from buildings and to prevent ponding. Finish subgrades to required elevations within the following tolerances:
1. Turf or Unpaved Areas: Plus or minus **1 inch**.
 2. Walks: Plus or minus **1/2 inch**.
 3. Pavements: Plus or minus **1/2 inch**.
- C. Grading inside Building Lines: Finish subgrade to a tolerance of **1/2 inch** when tested with a **10-foot** straightedge.

3.16 SUBBASE AND BASE COURSES UNDER PAVEMENTS AND WALKS

- A. Place subbase course on subgrades free of mud, frost, snow, or ice.
- B. On prepared subgrade, place subbase course under pavements and walks as follows:
1. Install separation geotextile on prepared subgrade per manufacturer's written instructions, overlapping sides and ends, if required.
 2. Shape subbase course to required crown elevations and cross-slope grades.

Weedsport Addition to Maintenance Section and Roof Replacement, MP 304.2

3. Place subbase course **6 inches** or less in compacted thickness in a single layer.
4. Place subbase course that exceeds **6 inches** in compacted thickness in layers of equal thickness, with no compacted layer more than **6 inches** thick or less than **3 inches** thick.
5. Compact subbase course at optimum moisture content to required grades, lines, cross sections, and thickness to not less than 95 percent of maximum dry unit weight per ASTM D 1557.

3.17 DRAINAGE COURSE UNDER CONCRETE SLABS-ON-GRADE

- A. Place drainage course on subgrades free of mud, frost, snow, or ice.
- B. On prepared subgrade, place and compact drainage course under cast-in-place concrete slabs-on-grade as follows:
 1. Install subdrainage geotextile on prepared subgrade per manufacturer's written instructions, overlapping sides and ends.
 2. Place drainage course **6 inches** or less in compacted thickness in a single layer.
 3. Place drainage course that exceeds **6 inches** in compacted thickness in layers of equal thickness, with no compacted layer more than **6 inches** thick or less than **3 inches** thick.
 4. Compact each layer of drainage course to required cross sections and thicknesses to not less than 95 percent of maximum dry unit weight per ASTM D 698.

3.18 FIELD QUALITY CONTROL

- A. Special Inspections: Owner may engage a qualified special inspector to perform the following special inspections:
 1. Determine prior to placement of fill that site has been prepared in compliance with requirements.
 2. Determine that fill material and maximum lift thickness comply with requirements.
 3. Determine, at the required frequency, that in-place density of compacted fill complies with requirements.
- B. Testing Agency: Owner may engage a qualified geotechnical engineering testing agency to perform tests and inspections.
- C. Allow testing agency to inspect and test subgrades and each fill or backfill layer. Proceed with subsequent earth moving only after test results for previously completed work comply with requirements.
- D. Footing Subgrade: At footing subgrades, at least one test of each soil stratum will be performed to verify design bearing capacities. Subsequent verification and approval of other footing subgrades may be based on a visual comparison of subgrade with tested subgrade when approved by Owner's Representative.
- E. Testing agency will test compaction of soils in place according to ASTM D 1556, ASTM D 2167, ASTM D 2922, and ASTM D 2937, as applicable. Tests will be performed at the following locations and frequencies:
 1. Paved and Building Slab Areas: At subgrade and at each compacted fill and backfill layer, at least one test for every 2,500 square feet or less of paved area or building slab, but in no case fewer than three tests.
 2. Foundation Wall Backfill: At each compacted backfill layer, at least one test for every 50 lineal feet or less of wall length, but no fewer than two tests.
 3. Trench Backfill: At each compacted initial and final backfill layer, at least one test for every 50 lineal feet or less of trench length, but no fewer than two tests.

Weedsport Addition to Maintenance Section and Roof Replacement, MP 304.2

- F. When testing agency reports that subgrades, fills, or backfills have not achieved degree of compaction specified, scarify and moisten or aerate, or remove and replace soil materials to depth required; recompact and retest until specified compaction is obtained.

3.19 PROTECTION

- A. Protecting Graded Areas: Protect newly graded areas from traffic, freezing, and erosion. Keep free of trash and debris.
- B. Repair and reestablish grades to specified tolerances where completed or partially completed surfaces become eroded, rutted, settled, or where they lose compaction due to subsequent construction operations or weather conditions.
 - 1. Scarify or remove and replace soil material to depth as directed by Owner's Representative; reshape and recompact.
- C. Where settling occurs before Project correction period elapses, remove finished surfacing, backfill with additional soil material, compact, and reconstruct surfacing.
 - 1. Restore appearance, quality, and condition of finished surfacing to match adjacent work, and eliminate evidence of restoration to greatest extent possible.

3.20 DISPOSAL OF SURPLUS AND WASTE MATERIALS

- A. Remove surplus satisfactory liquid, soil and waste materials, including dewatering liquids, silt, unsatisfactory soil, trash, and debris, and legally dispose of them off Owner's property.

END OF SECTION 312000

THIS PAGE INTENTIONALLY LEFT BLANK

SECTION 312319 - DEWATERING

PART 1 - GENERAL

1.1 RELATED DOCUMENTS

- A. Drawings and general provisions of the Contract, Division 01 Specification Sections, apply to this Section.

1.2 ACTION SUBMITTALS

- A. Shop Drawings: For dewatering system, prepared by or under the supervision of a qualified professional engineer.
1. Include plans, elevations, sections, and details.
 2. Show arrangement, locations, and details of wells and well points; locations of risers, headers, filters, pumps, power units, and discharge lines; and means of discharge, control of sediment, and disposal of water.
 3. Include layouts of piezometers and flow-measuring devices for monitoring performance of dewatering system.
 4. Include written plan for dewatering operations including sequence of well and well-point placement coordinated with excavation shoring and bracings and control procedures to be adopted if dewatering problems arise.

1.3 FIELD CONDITIONS

- A. Project-Site Information: A geotechnical report has been prepared for this Project and is available for information only. The opinions expressed in this report are those of a geotechnical engineer and represent interpretations of subsoil conditions, tests, and results of analyses conducted by a geotechnical engineer. Owner is not responsible for interpretations or conclusions drawn from this data.
1. Make additional test borings and conduct other exploratory operations necessary for dewatering according to the performance requirements.
- B. Survey Work: Engage a qualified land surveyor or professional engineer to survey adjacent existing buildings, structures, and site improvements; establish exact elevations at fixed points to act as benchmarks. Clearly identify benchmarks and record existing elevations.

PART 2 - PRODUCTS

2.1 PERFORMANCE REQUIREMENTS

- A. Dewatering Performance: Design, furnish, install, test, operate, monitor, and maintain dewatering system of sufficient scope, size, and capacity to control hydrostatic pressures and to lower, control, remove, and dispose of ground water and permit excavation and construction to proceed on dry, stable subgrades.
1. Design dewatering system, including comprehensive engineering analysis by a qualified professional engineer.
 2. Continuously monitor and maintain dewatering operations to ensure erosion control, stability of excavations and constructed slopes, prevention of flooding in excavation, and prevention of damage to subgrades and permanent structures.
 3. Prevent surface water from entering excavations by grading, dikes, or other means.

Weedsport Addition to Maintenance Section and Roof Replacement, MP 304.2

4. Accomplish dewatering without damaging existing buildings, structures, and site improvements adjacent to excavation.
 5. Remove dewatering system when no longer required for construction.
- B. Regulatory Requirements: Comply with governing EPA notification regulations before beginning dewatering. Comply with water- and debris-disposal regulations of authorities having jurisdiction.

PART 3 - EXECUTION

3.1 PREPARATION

- A. Protect structures, utilities, sidewalks, pavements, and other facilities from damage caused by settlement, lateral movement, undermining, washout, and other hazards created by dewatering operations.
1. Prevent surface water and subsurface or ground water from entering excavations, from ponding on prepared subgrades, and from flooding site or surrounding area.
 2. Protect subgrades and foundation soils from softening and damage by rain or water accumulation.
- B. Install dewatering system to ensure minimum interference with roads, streets, walks, and other adjacent occupied and used facilities.
1. Do not close or obstruct streets, walks, or other adjacent occupied or used facilities without permission from Owner and authorities having jurisdiction. Provide alternate routes around closed or obstructed traffic ways if required by authorities having jurisdiction.
- C. Provide temporary grading to facilitate dewatering and control of surface water.
- D. Protect and maintain temporary erosion and sedimentation controls, during dewatering operations.

3.2 INSTALLATION

- A. Install dewatering system utilizing wells, well points, or similar methods complete with pump equipment, standby power and pumps, filter material gradation, valves, appurtenances, water disposal, and surface-water controls.
1. Space well points or wells at intervals required to provide sufficient dewatering.
 2. Use filters or other means to prevent pumping of fine sands or silts from the subsurface.
- B. Place dewatering system into operation to lower water to specified levels before excavating below ground-water level.
- C. Provide sumps, sedimentation tanks, and other flow-control devices as required by authorities having jurisdiction.
- D. Provide standby equipment on-site, installed and available for immediate operation, to maintain dewatering on continuous basis if any part of system becomes inadequate or fails.

3.3 OPERATION

- A. Operate system continuously until drains, sewers, and structures have been constructed and fill materials have been placed or until dewatering is no longer required.
- B. Operate system to lower and control ground water to permit excavation, construction of structures, and placement of fill materials on dry subgrades. Drain water-bearing strata above and below bottom of foundations, drains, sewers, and other excavations.
1. Do not permit open-sump pumping that leads to loss of fines, soil piping, subgrade softening, and slope instability.

Weedsport Addition to Maintenance Section and Roof Replacement, MP 304.2

2. Reduce hydrostatic head in water-bearing strata below subgrade elevations of foundations, drains, sewers, and other excavations.
- C. Dispose of water removed by dewatering in a manner that avoids endangering public health, property, and portions of work under construction or completed. Dispose of water and sediment in a manner that avoids inconvenience to others.
- D. Remove dewatering system from Project site on completion of dewatering. Plug or fill well holes with sand or cut off and cap wells a minimum of 36 inches below overlying construction.

3.4 FIELD QUALITY CONTROL

- A. Observation Wells: Provide observation wells or piezometers, take measurements, and maintain at least the minimum number indicated; additional observation wells may be required by authorities having jurisdiction.
 1. Observe and record daily elevation of ground water and piezometric water levels in observation wells.
 2. Repair or replace, within 24 hours, observation wells that become inactive, damaged, or destroyed. In areas where observation wells are not functioning properly, suspend construction activities until reliable observations can be made. Add or remove water from observation-well risers to demonstrate that observation wells are functioning properly.
 3. Fill observation wells, remove piezometers, and fill holes when dewatering is completed.
- B. Provide continual observation to ensure that subsurface soils are not being removed by the dewatering operation.
- C. Prepare reports of observations.

3.5 PROTECTION

- A. Protect and maintain dewatering system during dewatering operations.
- B. Promptly repair damages to adjacent facilities caused by dewatering.

END OF SECTION 312319

SECTION 315000 - EXCAVATION SUPPORT AND PROTECTION

PART 1 - GENERAL

1.1 RELATED DOCUMENTS

- A. Drawings and general provisions of the Contract, Division 01 Specification Sections, apply to this Section.

1.2 SUMMARY

- A. Section includes temporary excavation support and protection systems.

1.3 SUBMITTALS

- A. Delegated-Design Submittal: For excavation support and protection systems, including analysis data signed and sealed by the qualified professional engineer responsible for their preparation.
 - 1. Professional Engineer: Experience with providing delegated-design engineering services of the type indicated, including documentation that engineer is licensed in the State in which Project is located.
- B. Architect/Engineer will not be responsible for review shoring design. Furnish record copy for Architect and Engineer.

1.4 FIELD CONDITIONS

- A. Interruption of Existing Utilities: Do not interrupt any utility serving facilities occupied by Owner or others unless permitted under the following conditions and then only after arranging to provide temporary utility according to requirements indicated:
 - 1. Notify **Owner** no fewer than **two** days in advance of proposed interruption of utility.
 - 2. Do not proceed with interruption of utility without written permission.
- B. Project-Site Information: A geotechnical report has been prepared for this Project and is available for information only. The opinions expressed in this report are those of a geotechnical engineer and represent interpretations of subsoil conditions, tests, and results of analyses conducted by a geotechnical engineer. Owner is not responsible for interpretations or conclusions drawn from the data.
 - 1. Make additional test borings and conduct other exploratory operations necessary for excavation support and protection according to the performance requirements.
- C. Survey Work: Engage a qualified land surveyor or professional engineer to survey adjacent existing buildings, structures, and site improvements; establish exact elevations at fixed points to act as benchmarks. Clearly identify benchmarks and record existing elevations.

PART 2 - PRODUCTS

2.1 PERFORMANCE REQUIREMENTS

- A. Provide, monitor, and maintain excavation support and protection system capable of supporting excavation sidewalls and of resisting earth and hydrostatic pressures and superimposed and construction loads.

Weedsport Addition to Maintenance Section and Roof Replacement, MP 304.2

1. Contractor Design: Design excavation support and protection system, including comprehensive engineering analysis by a qualified professional engineer.
2. Prevent surface water from entering excavations by grading, dikes, or other means.
3. Install excavation support and protection systems without damaging existing buildings, structures, and site improvements adjacent to excavation.
4. Continuously monitor vibrations, settlements, and movements to ensure stability of excavations and constructed slopes and to ensure that damage to permanent structures is prevented.

2.2 MATERIALS

- A. General: Provide materials that are either new or in serviceable condition and shall be provided with enough size and strength rating as determined by the application.
- B. Excavation shoring or underpinning materials shall be designed and provided to resist the influence of loads from adjacent existing structures, roadways, etc. shown on the Contract Drawings as well as supporting excavation sidewalls and of resisting earth and hydrostatic pressures and superimposed and construction loads.

PART 3 - EXECUTION

3.1 PREPARATION

- A. Protect structures, utilities, sidewalks, pavements, and other facilities from damage caused by settlement, lateral movement, undermining, washout, and other hazards that could develop during excavation support and protection system operations.
 1. Shore, support, and protect utilities encountered.
- B. Install excavation support and protection systems to ensure minimum interference with roads, streets, walks, and other adjacent occupied and used facilities.
 1. Do not close or obstruct streets, walks, or other adjacent occupied or used facilities without permission from Owner and authorities having jurisdiction. Provide alternate routes around closed or obstructed traffic ways if required by authorities having jurisdiction.
- C. Locate excavation support and protection systems clear of permanent construction so that construction and finishing of other work is not impeded.

3.2 SOLDIER PILES AND LAGGING

- A. Install steel soldier piles before starting excavation. Extend soldier piles below excavation grade level to depths adequate to prevent lateral movement. Space soldier piles at regular intervals not to exceed allowable flexural strength of wood lagging. Accurately align exposed faces of flanges to vary not more than **2 inches from a horizontal line and not more than 1:120 out of vertical alignment**].
- B. Install wood lagging within flanges of soldier piles as excavation proceeds. Trim excavation as required to install lagging. Fill voids behind lagging with soil, and compact.
- C. Install wales horizontally at locations indicated on Drawings and secure to soldier piles.

Weedsport Addition to Maintenance Section and Roof Replacement, MP 304.2

3.3 SHEET PILING

- A. Before starting excavation, install one-piece sheet piling lengths and tightly interlock vertical edges to form a continuous barrier.
- B. Accurately place the piling, using templates and guide frames unless otherwise recommended in writing by the sheet piling manufacturer. Limit vertical offset of adjacent sheet piling to **60 inches**. Accurately align exposed faces of sheet piling to vary not more than **2 inches from a horizontal line and not more than 1:120 out of vertical alignment**.
- C. Cut tops of sheet piling to uniform elevation at top of excavation.

3.4 TIEBACKS

- A. Drill, install, grout, and tension tiebacks.
- B. Test load-carrying capacity of each tieback and replace and retest deficient tiebacks.
 - 1. Have test loading observed by a qualified professional engineer responsible for design of excavation support and protection system.
- C. Maintain tiebacks in place until permanent construction is able to withstand lateral earth and hydrostatic pressures.

3.5 BRACING

- A. Bracing: Locate bracing to clear columns, floor framing construction, and other permanent work. If necessary to move brace, install new bracing before removing original brace.
 - 1. Do not place bracing where it will be cast into or included in permanent concrete work unless otherwise approved by Architect.
 - 2. Install internal bracing if required to prevent spreading or distortion of braced frames.
 - 3. Maintain bracing until structural elements are supported by other bracing or until permanent construction is able to withstand lateral earth and hydrostatic pressures.

3.6 FIELD QUALITY CONTROL

- A. Survey-Work Benchmarks: Resurvey benchmarks **regularly** during installation of excavation support and protection systems, excavation progress, and for as long as excavation remains open. Maintain an accurate log of surveyed elevations and positions for comparison with original elevations and positions. Promptly notify Architect if changes in elevations or positions occur or if cracks, sags, or other damage is evident in adjacent construction.
- B. Promptly correct detected bulges, breakage, or other evidence of movement to ensure that excavation support and protection system remains stable.
- C. Promptly repair damages to adjacent facilities caused by installation or faulty performance of excavation support and protection systems.

3.7 REMOVAL AND REPAIRS

- A. Remove excavation support and protection systems when construction has progressed sufficiently to support excavation and earth and hydrostatic pressures. Remove in stages to avoid disturbing underlying soils and rock or damaging structures, pavements, facilities, and utilities.
 - 1. Remove excavation support and protection systems to a minimum depth of **48 inches** below overlying construction and abandon remainder.
 - 2. Fill voids immediately with approved backfill compacted to density specified in Section 312000 "Earth Moving."

Weedsport Addition to Maintenance Section and Roof Replacement, MP 304.2

3. Repair or replace, as approved by Architect, adjacent work damaged or displaced by removing excavation support and protection systems.
- B. Leave excavation support and protection systems permanently in place.

END OF SECTION 315000

ITEM 627.0032 25**EXTERIOR IMPROVEMENTS****1. DESCRIPTION:**

- 1.01 Furnish all labor, materials, equipment and services necessary to complete the work as indicated on the Contract Plans and the Specification Sections listed below
- 1.04 All work shall conform to the requirements specified in Part 1 – General, of the Sections listed.

2. MATERIALS:

- 2.01 The materials shall be as specified in Part 2 – Products, of the Sections listed.

3. CONSTRUCTION DETAILS:

- 3.01 The construction details shall be as specified on Part 3 – Execution, if the Sections listed.

4. METHOD OF MEASUREMENT:

- 4.01 This item shall be measured for payment on a lump sum basis for the work completed in accordance with the Contract Documents and as directed by the Engineer.

5. BASIS OF PAYMENT:

- 5.01 Payment for this item shall be made at the lump sum bid price bid. The lump sum price bid shall include cost of furnishing all labor, material, equipment and appliances necessary to complete the work as indicated on the Contract Plans and as specified herein in the Sections listed.
- 5.02 Detailed Estimate:
 - A. Before the first certificate of payment is issued for the work under this item, submit a detailed estimate of quantities and prices for all materials, labor, and other items included under this item, which shall aggregate the contract lump sum price bid for this item. Prepare the detailed estimate in the same sequence as the Sections listed.
 - B. The detailed estimate shall be supported by such evidence, including certified copies of subcontracts, as the Engineer may require.
 - C. The detailed estimate must be approved by the Engineer who may revise it as, in his/her reasonable judgment, is necessary to make the various item conform to their true values. The value of each certificate of payment will be based on the approved detailed estimate.
- 5.03 Monthly payments will be made for this item in proportion to the total amount of work completed.

ITEM 627.0032 25**EXTERIOR IMPROVEMENTS****1. SPECIFICATION SUMMARY**

1.01 This Item includes the following specifications:

- A. Section 321216 ASPHALT PAVING
- B. Section 321723 PAVEMENT MARKINGS
- C. Section 329200 TURF AND GRASSES

1.02 This item shall include, but not be limited to, the following:

- A. New paving around the building, including the addition of new parking spaces
- B. New green space around the building

SECTION 321216 - ASPHALT PAVING

PART 1 - GENERAL

1.1 SUMMARY

- A. Section Includes:
1. Hot-mix asphalt patching.
 2. Hot-mix asphalt paving.
 3. Hot-mix asphalt overlay.

1.2 PREINSTALLATION MEETINGS

- A. Preinstallation Conference: Conduct conference at Project site.
1. Review requirements for protecting paving work, including restriction of traffic during installation period and for remainder of construction period.

1.3 ACTION SUBMITTALS

- A. Product Data: For each type of product.
1. Include technical data and tested physical and performance properties.
 2. Job-Mix Designs: Certification, by authorities having jurisdiction, of approval of each job mix proposed for the Work.
 3. Job-Mix Designs: For each job mix proposed for the Work.

1.4 INFORMATIONAL SUBMITTALS

- A. Material Test Reports: For each paving material, by a qualified testing agency.

1.5 FIELD CONDITIONS

- A. Environmental Limitations: Do not apply asphalt materials if subgrade is wet or excessively damp, if rain is imminent or expected before time required for adequate cure, or if the following conditions are not met:
1. Asphalt Base Course: Minimum surface temperature of **40 deg F** and rising at time of placement.
 2. Asphalt Surface Course: Minimum surface temperature of **50 deg F** at time of placement.

PART 2 - PRODUCTS

2.1 AGGREGATES

- A. General: Use materials and gradations that have performed satisfactorily in previous installations.
- B. Coarse Aggregate: Sound; angular crushed stone, crushed gravel, or cured, crushed blast-furnace slag meeting the NYSDOT requirements for Coarse Aggregate 703-02.
- C. Fine Aggregate: Sharp-edged natural sand or sand prepared from stone, gravel, cured blast-furnace slag, or combinations thereof meeting the NYSDOT requirements for Fine Aggregate 703-01.
1. For hot-mix asphalt, limit natural sand to a maximum of 20 percent by weight of the total aggregate mass.
- D. Mineral Filler: ASTM D 242/D 242M, rock or slag dust, hydraulic cement, or other inert material.

Weedsport Addition to Maintenance Section and Roof Replacement, MP 304.2

2.2 ASPHALT MATERIALS

- A. Asphalt Binder: NYSDOT Performance Grade Binder designation PG 64S-22.
- B. Asphalt Cement: Meeting the requirements of NYSDOT Table 702-2.
- C. Tack Coat: Meeting the requirements of NYSDOT Table 702-5 cationic emulsified asphalt, slow setting, diluted in water, of suitable grade and consistency for application.
- D. Water: Potable.

2.3 AUXILIARY MATERIALS

- A. Paving Geotextile: Where specified on Contract Drawings. AASHTO M 288 paving fabric; nonwoven polypropylene; resistant to chemical attack, rot, and mildew; and specifically designed for paving applications.
- B. Joint Sealant: ASTM D 6690, Type II, hot-applied, single-component, polymer-modified bituminous sealant on NYSDOT-Approved List.

2.4 MIXES

- A. Hot-Mix Asphalt: Dense-graded, hot-laid, hot-mix asphalt plant mixes in compliance with the with NYSDOT specification mix requirements. If not otherwise called out on the drawings (plans), provide the following:
 - 1. Provide mixes with a history of satisfactory performance in geographical area where Project is located.
 - 2. Base Course: NYSDOT 37.5 F9 HMA 80 Series.
 - 3. Binder Course: NYSDOT 19 F9 HMA 80 Series.
 - 4. Top Course: NYSDOT 12.5 F2 HMA 80 Series..
- B. Emulsified-Asphalt Slurry: ASTM D 3910, Type 1.

PART 3 - EXECUTION**3.1 EXAMINATION**

- A. Verify that subgrade is dry and in suitable condition to begin paving.
- B. Proceed with paving only after unsatisfactory conditions have been corrected.

3.2 PREPARATION

- A. Protection: Provide protective materials, procedures, and worker training to prevent asphalt materials from spilling, coating, or building up on curbs, driveway aprons, manholes, and other surfaces adjacent to the Work.
- B. Proof-roll subgrade below pavements with heavy pneumatic-tired equipment to identify soft pockets and areas of excess yielding. Do not proof-roll wet or saturated subgrades.
 - 1. Completely proof-roll subgrade in one direction, repeating proof-rolling in direction perpendicular to first direction. Limit vehicle speed to **3 mph**.
 - 2. Proof roll with a loaded 10-wheel, tandem-axle dump truck weighing not less than **15 tons**.
 - 3. Excavate soft spots, unsatisfactory soils, and areas of excessive pumping or rutting, as determined by Architect, and replace with compacted backfill or fill as directed.

Weedsport Addition to Maintenance Section and Roof Replacement, MP 304.2

3.3 COLD MILLING

- A. Clean existing pavement surface of loose and deleterious material immediately before cold milling. Remove existing asphalt pavement by cold milling to grades and cross sections indicated.
1. Mill to a depth as indicated on the Contract Documents.
 2. Mill to a uniform finished surface free of excessive gouges, grooves, and ridges.
 3. Control rate of milling to prevent tearing of existing asphalt course.
 4. Repair or replace curbs, driveway aprons, manholes, and other construction damaged during cold milling.
 5. Excavate and trim unbound-aggregate base course, if encountered, and keep material separate from milled hot-mix asphalt.
 6. Patch surface depressions deeper than **1 inch** after milling, before wearing course is laid.
 7. Unless otherwise specified in the Contract Documents, remove and legally dispose of milling from the site.
 8. Keep milled pavement surface free of loose material and dust.
 9. Do not allow milled materials to accumulate on-site.

3.4 PATCHING

- A. Asphalt Pavement: Saw cut perimeter of patch and excavate existing pavement section to sound base. Excavate rectangular or trapezoidal patches, extending **12 inches** into perimeter of adjacent sound pavement, unless otherwise indicated. Cut excavation faces vertically. Remove excavated material. Recompact existing unbound-aggregate base course to form new subgrade.
- B. Portland Cement Concrete Pavement: Break cracked slabs and roll as required to reseat concrete pieces firmly.
1. Undersealing: Pump hot undersealing asphalt under rocking slab until slab is stabilized or, if necessary, crack slab into pieces and roll to reseat pieces firmly.
 2. Remove disintegrated or badly cracked pavement. Excavate rectangular or trapezoidal patches, extending into perimeter of adjacent sound pavement, unless otherwise indicated. Cut excavation faces vertically. Recompact existing unbound-aggregate base course to form new subgrade.
- C. Tack Coat: Before placing patch material, apply tack coat uniformly to vertical asphalt surfaces abutting the patch. Apply at a rate of **0.05 to 0.15 gal./sq. yd.**
1. Allow tack coat to cure undisturbed before applying hot-mix asphalt paving.
 2. Avoid smearing or staining adjoining surfaces, appurtenances, and surroundings. Remove spillages and clean affected surfaces.
- D. Placing Patch Material: Fill excavated pavement areas with hot-mix asphalt base mix for full thickness of patch and, while still hot, compact flush with adjacent surface.

3.5 REPAIRS

- A. Leveling Course: Install and compact leveling course consisting of hot-mix asphalt surface course to level sags and fill depressions deeper than **1 inch** in existing pavements.
1. Install leveling wedges in compacted lifts not exceeding **3 inches** thick.
- B. Crack and Joint Filling: Remove existing joint filler material from cracks or joints to a depth of **1/4 inch**.
1. Clean cracks and joints in existing hot-mix asphalt pavement.
 2. Use emulsified-asphalt slurry to seal cracks and joints less than **1/4 inch** wide. Fill flush with surface of existing pavement and remove excess.

Weedsport Addition to Maintenance Section and Roof Replacement, MP 304.2

3. Use hot-applied joint sealant to seal cracks and joints more than **1/4 inch** wide. Fill flush with surface of existing pavement and remove excess.

3.6 SURFACE PREPARATION

- A. Immediately before placing asphalt materials, remove loose and deleterious material from substrate surfaces. Ensure that prepared subgrade is ready to receive paving.
- B. Tack Coat: Apply uniformly to surfaces of existing pavement at a rate of **0.05 to 0.15 gal./sq. yd.**
 1. Allow tack coat to cure undisturbed before applying hot-mix asphalt paving.
 2. Avoid smearing or staining adjoining surfaces, appurtenances, and surroundings. Remove spillages and clean affected surfaces.

3.7 PAVING GEOTEXTILE INSTALLATION (IF REQUIRED)

- A. Apply tack coat uniformly to existing pavement surfaces at a rate of **0.20 to 0.30 gal./sq. yd.**
- B. Place paving geotextile promptly according to manufacturer's written instructions. Broom or roll geotextile smooth and free of wrinkles and folds. Overlap longitudinal joints **4 inches** and transverse joints **6 inches**.
- C. Protect paving geotextile from traffic and other damage, and place hot-mix asphalt overlay the same day.

3.8 PLACING HOT-MIX ASPHALT

- A. Machine place hot-mix asphalt on prepared surface, spread uniformly, and strike off. Place asphalt mix by hand in areas inaccessible to equipment in a manner that prevents segregation of mix. Place each course to required grade, cross section, and thickness when compacted.
 1. Place hot-mix asphalt base and binder course in single lifts.
 2. Place hot-mix asphalt surface course in single lift.
 3. Spread mix at a minimum temperature of **250 deg F**.
 4. Begin applying mix along centerline of crown for crowned sections and on high side of one-way slopes unless otherwise indicated.
 5. Regulate paver machine speed to obtain smooth, continuous surface free of pulls and tears in asphalt-paving mat.
- B. Place paving in consecutive strips not less than **10 feet** wide unless infill edge strips of a lesser width are required.
 1. After first strip has been placed and rolled, place succeeding strips and extend rolling to overlap previous strips. Overlap mix placement about **1 to 1-1/2 inches** from strip to strip to ensure proper compaction of mix along longitudinal joints.
 2. Complete a section of asphalt base course before placing asphalt surface course.
- C. Promptly correct surface irregularities in paving course behind paver. Use suitable hand tools to remove excess material forming high spots. Fill depressions with hot-mix asphalt to prevent segregation of mix; use suitable hand tools to smooth surface.

3.9 JOINTS

- A. Construct joints to ensure a continuous bond between adjoining paving sections. Construct joints free of depressions, with same texture and smoothness as other sections of hot-mix asphalt course.
 1. Clean contact surfaces and apply tack coat to joints.
 2. Offset longitudinal joints, in successive courses, a minimum of **6 inches**.
 3. Offset transverse joints, in successive courses, a minimum of **24 inches**.

Weedsport Addition to Maintenance Section and Roof Replacement, MP 304.2

4. Construct transverse joints at each point where paver ends a day's work and resumes work at a subsequent time.
5. Compact joints as soon as hot-mix asphalt will bear roller weight without excessive displacement.
6. Compact asphalt at joints to a density within 2 percent of specified course density.

3.10 COMPACTION

- A. General: Begin compaction as soon as placed hot-mix paving will bear roller weight without excessive displacement. Compact hot-mix paving with hot, hand tampers or with vibratory-plate compactors in areas inaccessible to rollers.
 1. Complete compaction before mix temperature cools to **185 deg F**.
- B. Breakdown Rolling: Complete breakdown or initial rolling immediately after rolling joints and outside edge. Examine surface immediately after breakdown rolling for indicated crown, grade, and smoothness. Correct laydown and rolling operations to comply with requirements.
- C. Intermediate Rolling: Begin intermediate rolling immediately after breakdown rolling while hot-mix asphalt is still hot enough to achieve specified density. Continue rolling until hot-mix asphalt course has been uniformly compacted to the following density:
 1. Average Density: 96 percent of reference laboratory density according to ASTM D 6927, but not less than 94 percent or greater than 100 percent.
- D. Finish Rolling: Finish roll paved surfaces to remove roller marks while hot-mix asphalt is still warm.
- E. Edge Shaping: While surface is being compacted and finished, trim edges of pavement to proper alignment. Bevel edges while asphalt is still hot; compact thoroughly.
- F. Repairs: Remove paved areas that are defective or contaminated with foreign materials and replace with fresh, hot-mix asphalt. Compact by rolling to specified density and surface smoothness.
- G. Protection: After final rolling, do not permit vehicular traffic on pavement until it has cooled and hardened.
- H. Erect barricades to protect paving from traffic until mixture has cooled enough not to become marked.

3.11 ASPHALT CURBS (IF REQUIRED)

- A. Construct hot-mix asphalt curbs over compacted pavement surfaces. Apply a light tack coat unless pavement surface is still tacky and free from dust. Spread mix at a minimum temperature of **250 deg F**.
 1. Asphalt Mix: Same as pavement surface-course mix.
- B. Place hot-mix asphalt to curb cross section indicated or, if not indicated, to local standard shapes, by machine or by hand in wood or metal forms. Tamp hand-placed materials and screed to smooth finish. Remove forms after hot-mix asphalt has cooled.

3.12 ASPHALT TRAFFIC-CALMING DEVICES (IF REQUIRED)

- A. Construct hot-mix asphalt speed humps over compacted pavement surfaces. Apply a tack coat unless pavement surface is still tacky and free from dust. Spread mix at a minimum temperature of **250 deg F**.
 1. Tack Coat Application: Apply uniformly to surfaces of existing pavement at a rate of **0.05 to 0.15 gal./sq. yd.**

Weedsport Addition to Maintenance Section and Roof Replacement, MP 304.2

2. Asphalt Mix: Same as pavement surface-course mix.
 3. Before installation, mill pavement that will be in contact with bottom of traffic-calming device. Mill to a depth of **1 inch** from top of pavement to a clean, rough profile.
- B. Place and compact hot-mix asphalt to cross section indicated, by machine or by hand in wood or metal forms. Tamp hand-placed materials and screed to smooth finish. Remove forms after hot-mix asphalt has cooled.

3.13 INSTALLATION TOLERANCES

- A. Pavement Thickness: Compact each course to produce the thickness indicated within the following tolerances:
1. Base Course: Plus or minus **1/2 inch**.
 2. Surface Course: Plus **1/4 inch**, no minus.
- B. Pavement Surface Smoothness: Compact each course to produce a surface smoothness within the following tolerances as determined by using a **10-foot** straightedge applied transversely or longitudinally to paved areas:
1. Base Course: **1/4 inch**.
 2. Surface Course: **1/8 inch**.
 3. Crowned Surfaces: Test with crowned template centered and at right angle to crown. Maximum allowable variance from template is **1/4 inch**.
- C. Asphalt Traffic-Calming Devices: Compact and form asphalt to produce the contour indicated and within a tolerance of plus or minus **1/8 inch** of height indicated above pavement surface.

3.14 SURFACE TREATMENTS (IF REQUIRED)

- A. Fog Seals: Apply fog seal at a rate of **0.10 to 0.15 gal./sq. yd.** to existing asphalt pavement and allow to cure. With fine sand, lightly dust areas receiving excess fog seal.
- B. Slurry Seals: Apply slurry coat in a uniform thickness according to ASTM D 3910 and allow to cure.
1. Roll slurry seal to remove ridges and provide a uniform, smooth surface.

3.15 FIELD QUALITY CONTROL

- A. Testing Agency: Owner will engage a qualified testing agency to perform tests and inspections.
- B. Thickness: In-place compacted thickness of hot-mix asphalt courses will be determined according to ASTM D 3549/D 3549M.
- C. Surface Smoothness: Finished surface of each hot-mix asphalt course will be tested for compliance with smoothness tolerances.
- D. Asphalt Traffic-Calming Devices: Finished height of traffic-calming devices above pavement will be measured for compliance with tolerances.
- E. In-Place Density: Testing agency will take samples of uncompacted paving mixtures and compacted pavement according to ASTM D 979/D 979M.
1. Reference maximum theoretical density will be determined by averaging results from four samples of hot-mix asphalt-paving mixture delivered daily to site, prepared according to ASTM D 2041/D 2041M, and compacted according to job-mix specifications.
 2. In-place density of compacted pavement will be determined by testing core samples according to ASTM D 1188 or ASTM D 2726/D 2726M.

Weedsport Addition to Maintenance Section and Roof Replacement, MP 304.2

- a. Field density of in-place compacted pavement may also be determined by nuclear method according to ASTM D 2950 and correlated with ASTM D 1188 or ASTM D 2726/D 2726M.
- F. Replace and compact hot-mix asphalt where core tests were taken, if any.
- G. Remove and replace or install additional hot-mix asphalt where test results or measurements indicate that it does not comply with specified requirements.

END OF SECTION 321216

SECTION 321723 - PAVEMENT MARKINGS

PART 1 - GENERAL

1.1 SUMMARY

- A. Section includes painted markings applied to asphalt and concrete pavement.

1.2 PREINSTALLATION MEETINGS

- A. Preinstallation Conference: Conduct conference at Project site.
1. Review methods and procedures related to marking pavement including, but not limited to, the following:
 - a. Pavement aging period before application of pavement markings.
 - b. Review requirements for protecting pavement markings, including restriction of traffic during installation period.

1.3 ACTION SUBMITTALS

- A. Product Data: For each type of product.
1. Include technical data and tested physical and performance properties.
- B. Shop Drawings: For pavement markings.
1. Indicate pavement markings, colors, lane separations, defined parking spaces, and dimensions to adjacent work.
 2. Indicate, with international symbol of accessibility, spaces allocated for people with disabilities.

1.4 QUALITY ASSURANCE

- A. Regulatory Requirements: Comply with materials, workmanship, and other applicable requirements of NYSDOT for pavement-marking work for any work within public right-of-way.

1.5 FIELD CONDITIONS

- A. Environmental Limitations: Proceed with pavement marking only on clean, dry surfaces and at a minimum ambient or surface temperature of 55° and a maximum of 95°.

PART 2 - PRODUCTS

2.1 PAVEMENT-MARKING PAINT

- A. Formulated for use as a pavement marking material.
- B. Be VOC compliant and lead chromate free.
- C. Yellow paints must use organic yellow pigments Color Index Pigment Yellow 65 (C.I. 11740) and/or 74 (C.I. 11741).
- D. Display no bleeding on the surface upon which the paint is applied.
- E. Conform to current Federal, State and Local air pollution regulations, including those for the control (emission) of volatile organic compounds (VOC) as established by the U.S. EPA, and the NYSDEC
- F. % Pigment. (ASTM D3723) 58.0% – 62.0%

Weedsport Addition to Maintenance Section and Roof Replacement, MP 304.2

- G. % Total Solids. (ASTM D3723) 76.0 % minimum
- H. % Vehicle Non-Volatile. (ASTM D3723) 43.0 % minimum
- I. Directional Reflectance (ASTM E1347)
 - 1. White: 84% minimum
 - 2. Yellow: 54% minimum

PART 3 - EXECUTION

3.1 EXAMINATION

- A. Verify that pavement is dry and in suitable condition to begin pavement marking according to manufacturer's written instructions.
- B. Proceed with pavement marking only after unsatisfactory conditions have been corrected.

3.2 PAVEMENT MARKING

- A. Do not apply pavement-marking paint until layout, colors, and placement have been verified with Owner's Representative.
- B. Allow paving to age for a minimum of 30 days before starting pavement marking, unless approved in writing by Owner's Representative.
- C. Sweep and clean surface to eliminate loose material and dust.
- D. Apply paint with mechanical equipment to produce pavement markings, of dimensions indicated, with uniform, straight edges. Apply at manufacturer's recommended rates.
 - 1. Apply graphic symbols and lettering with paint-resistant, die-cut stencils, firmly secured to pavement. Mask an extended area beyond edges of each stencil to prevent paint application beyond stencil. Apply paint so that it cannot run beneath stencil.

3.3 PROTECTING AND CLEANING

- A. Protect pavement markings from damage and wear until completely dry, as recommended by paint manufacturer.
- B. Clean spillage and soiling from adjacent construction using cleaning agents and procedures recommended by manufacturer of affected construction.

END OF SECTION 321723

SECTION 329200 - TURF AND GRASSES

PART 1 - GENERAL

1.1 SUMMARY

- A. Section Includes:
 - 1. Seeding.
 - 2. Hydroseeding.
 - 3. Sodding.

1.2 DEFINITIONS

- A. Finish Grade: Elevation of finished surface of planting soil.
- B. Planting Soil: Existing, on-site soil; imported soil; or manufactured soil that has been modified with soil amendments and perhaps fertilizers to produce a soil mixture best for plant growth.
- C. Subgrade: The surface or elevation of subsoil remaining after excavation is complete, or the top surface of a fill or backfill before planting soil is placed.

1.3 PREINSTALLATION MEETINGS

- A. Preinstallation Conference: Conduct conference at Project site.

1.4 INFORMATIONAL SUBMITTALS

- A. Qualification Data: For landscape Installer.
- B. Certification of Grass Seed: From seed vendor for each grass-seed monostand or mixture, stating the botanical and common name, percentage by weight of each species and variety, and percentage of purity, germination, and weed seed. Include the year of production and date of packaging.
 - 1. Certification of each seed mixture for turfgrass sod. Include identification of source and name and telephone number of supplier.
- C. Product Certificates: For fertilizers, from manufacturer.

1.5 DELIVERY, STORAGE, AND HANDLING

- A. Seed and Other Packaged Materials: Deliver packaged materials in original, unopened containers showing weight, certified analysis, name and address of manufacturer, and indication of compliance with state and Federal laws, as applicable.
- B. Sod: Harvest, deliver, store, and handle sod according to requirements in "Specifications for Turfgrass Sod Materials" and "Specifications for Turfgrass Sod Transplanting and Installation" sections in TPI's "Guideline Specifications to Turfgrass Sodding." Deliver sod within 24 hours of harvesting and in time for planting promptly. Protect sod from breakage and drying.
- C. Bulk Materials:
 - 1. Do not dump or store bulk materials near structures, utilities, walkways and pavements, or on existing turf areas or plants.
 - 2. Provide erosion-control measures to prevent erosion or displacement of bulk materials; discharge of soil-bearing water runoff; and airborne dust reaching adjacent properties, water conveyance systems, or walkways.
 - 3. Accompany each delivery of bulk materials with appropriate certificates.

Weedsport Addition to Maintenance Section and Roof Replacement, MP 304.2

1.6 FIELD CONDITIONS

- A. Planting Restrictions: Plant during one of the following periods. Coordinate planting periods with initial maintenance periods to provide required maintenance from date of planting completion.
- B. Weather Limitations: Proceed with planting only when existing and forecasted weather conditions permit planting to be performed when beneficial and optimum results may be obtained. Apply products during favorable weather conditions according to manufacturer's written instructions.

PART 2 - PRODUCTS**2.1 SEED**

- A. Grass Seed: Fresh, clean, dry, new-crop seed complying with AOSA's "Rules for Testing Seeds" for purity and germination tolerances.
- B. Seed Species:
 - 1. Quality: State-certified seed of grass species as listed below for solar exposure.
 - 2. Sun and Partial Shade: Proportioned by weight as follows:
 - a. 50 percent Kentucky bluegrass (*Poa pratensis*).
 - b. 30 percent chewing red fescue (*Festuca rubra* variety).
 - c. 10 percent perennial ryegrass (*Lolium perenne*).
 - d. 10 percent redtop (*Agrostis alba*).
 - 3. Shade: Proportioned by weight as follows:
 - a. 50 percent chewing red fescue (*Festuca rubra* variety).
 - b. 35 percent rough bluegrass (*Poa trivialis*).
 - c. 15 percent redtop (*Agrostis alba*).

2.2 TURFGRASS SOD

- A. Sod shall be commercially grown sod and shall be accompanied by a certificate indicating compliance with the regulations of the NYS Department of Agriculture and Markets. Athletic field sod shall be 100% tall fescue.
- B. Sod shall be cut into squares or rectangular portions which shall be a minimum of 12 inches wide, or as approved, and may vary in length, but shall be of a size which will permit them to be lifted without breaking. Height of the grass shall not exceed 3 inches. The sod shall be cut to a minimum thickness of 3/4 inch. The sod shall be reasonably free from weeds in conformance with accepted commercial practice. The sod shall consist of a mixture of at least three permanent grasses such as bluegrass and fine leaved fescues, unless otherwise specified. Sod that is heat damaged or fermenting will be rejected.
- C. Sod shall be delivered to the job within 24 hours after being cut and installed within 48 hours after being cut. The sod, when delivered to the contract site and during the time it is held on site, shall be sufficiently moist so the soil will adhere firmly to the roots when it is handled.
- D. Sod will be accepted based on inspection for compliance with the material

2.3 FERTILIZERS

- A. Commercial Fertilizer: Commercial-grade complete fertilizer of neutral character, consisting of fast- and slow-release nitrogen, 50 percent derived from natural organic sources of urea formaldehyde, phosphorous, and potassium in the following composition:
 - 1. Composition: 1 lb/1000 sq. ft. of actual nitrogen, 4 percent phosphorous, and 2 percent potassium, by weight.

Weedsport Addition to Maintenance Section and Roof Replacement, MP 304.2

- B. Slow-Release Fertilizer: Granular or pelleted fertilizer consisting of 50 percent water-insoluble nitrogen, phosphorus, and potassium in the following composition:
 1. Composition: 20 percent nitrogen, 10 percent phosphorous, and 10 percent potassium, by weight.

2.4 MULCHES

- A. Straw Mulch: Provide air-dry, clean, mildew- and seed-free, salt hay or threshed straw of wheat, rye, oats, or barley.
 1. Organic Matter Content: 50 to 60 percent of dry weight.
- B. Fiber Mulch: Biodegradable, dyed-wood, cellulose-fiber mulch; nontoxic and free of plant-growth or germination inhibitors; with a maximum moisture content of 15 percent and a pH range of 4.5 to 6.5.
- C. Nonasphaltic Tackifier: Colloidal tackifier recommended by fiber-mulch manufacturer for slurry application; nontoxic and free of plant-growth or germination inhibitors.
- D. Asphalt Emulsion: ASTM D 977, Grade SS-1; nontoxic and free of plant-growth or germination inhibitors.

2.5 EROSION-CONTROL MATERIALS

- A. Erosion-Control Blankets: Biodegradable wood excelsior, straw, or coconut-fiber mat enclosed in a photodegradable plastic mesh. Include manufacturer's recommended steel wire staples, **6 inches** long.
- B. Erosion-Control Fiber Mesh: Biodegradable burlap or spun-coir mesh, a minimum of **0.92 lb/sq. yd.**, with 50 to 65 percent open area. Include manufacturer's recommended steel wire staples, **6 inches** long.
- C. Erosion-Control Mats: Cellular, nonbiodegradable slope-stabilization mats designed to isolate and contain small areas of soil over steeply sloped surface, of **3-inch** nominal mat thickness. Include manufacturer's recommended anchorage system for slope conditions.

PART 3 - EXECUTION**3.1 EXAMINATION**

- A. Examine areas to be planted for compliance with requirements and other conditions affecting installation and performance of the Work.
 1. Verify that no foreign or deleterious material or liquid such as paint, paint washout, concrete slurry, concrete layers or chunks, cement, plaster, oils, gasoline, diesel fuel, paint thinner, turpentine, tar, roofing compound, or acid has been deposited in soil within a planting area.
 2. Suspend planting operations during periods of excessive soil moisture until the moisture content reaches acceptable levels to attain the required results.
 3. Uniformly moisten excessively dry soil that is not workable or which is dusty.
- B. Proceed with installation only after unsatisfactory conditions have been corrected.
- C. If contamination by foreign or deleterious material or liquid is present in soil within a planting area, remove the soil and contamination as directed by Architect and replace with new planting soil.

Weedsport Addition to Maintenance Section and Roof Replacement, MP 304.2

3.2 PREPARATION

- A. Protect structures; utilities; sidewalks; pavements; and other facilities, trees, shrubs, and plantings from damage caused by planting operations.
 1. Protect adjacent and adjoining areas from hydroseeding and hydromulching overspray.
 2. Protect grade stakes set by others until directed to remove them.
- B. Install erosion-control measures to prevent erosion or displacement of soils and discharge of soil-bearing water runoff or airborne dust to adjacent properties and walkways.

3.3 TURF AREA PREPARATION

- A. Placing Planting Soil: Place and mix planting soil in place over exposed subgrade.
 1. Reduce elevation of planting soil to allow for soil thickness of sod.
- B. Moisten prepared area before planting if soil is dry. Water thoroughly and allow surface to dry before planting. Do not create muddy soil.
- C. Before planting, obtain Architect's acceptance of finish grading; restore planting areas if eroded or otherwise disturbed after finish grading.

3.4 PREPARATION FOR EROSION-CONTROL MATERIALS

- A. Prepare area as specified in "Turf Area Preparation" Article.
- B. For erosion-control mats, install planting soil in two lifts, with second lift equal to thickness of erosion-control mats. Install erosion-control mat and fasten as recommended by material manufacturer.
- C. Fill cells of erosion-control mat with planting soil and compact before planting.
- D. For erosion-control blanket or mesh, install from top of slope, working downward, and as recommended by material manufacturer for site conditions. Fasten as recommended by material manufacturer.
- E. Moisten prepared area before planting if surface is dry. Water thoroughly and allow surface to dry before planting. Do not create muddy soil.

3.5 SEEDING

- A. Sow seed with spreader or seeding machine. Do not broadcast or drop seed when wind velocity exceeds **5 mph**.
 1. Evenly distribute seed by sowing equal quantities in two directions at right angles to each other.
 2. Do not use wet seed or seed that is moldy or otherwise damaged.
 3. Do not seed against existing trees. Limit extent of seed to outside edge of planting saucer.
- B. Sow seed at a total rate of **3 to 4 lb/1000 sq. ft.**
- C. Rake seed lightly into top **1/8 inch** of soil, roll lightly, and water with fine spray.
- D. Protect seeded areas with slopes exceeding 1:4 with erosion-control blankets and 1:6 with erosion-control fiber mesh installed and stapled according to manufacturer's written instructions.
- E. Protect seeded areas with erosion-control mats where indicated on Drawings; install and anchor according to manufacturer's written instructions.

Weedsport Addition to Maintenance Section and Roof Replacement, MP 304.2

3.6 HYDROSEEDING

- A. Hydroseeding: Mix specified seed, commercial fertilizer, and fiber mulch in water, using equipment specifically designed for hydroseed application. Continue mixing until uniformly blended into homogeneous slurry suitable for hydraulic application.
1. Mix slurry with fiber-mulch manufacturer's recommended tackifier.
 2. Spray-apply slurry uniformly to all areas to be seeded in a one-step process. Apply slurry at a rate so that mulch component is deposited at not less than **1500-lb/acre** dry weight, and seed component is deposited at not less than the specified seed-sowing rate.

3.7 SODDING

- A. Lay sod within 24 hours of harvesting. Do not lay sod if dormant or if ground is frozen or muddy.
- B. Lay sod to form a solid mass with tightly fitted joints. Butt ends and sides of sod; do not stretch or overlap. Stagger sod strips or pads to offset joints in adjacent courses. Avoid damage to soil or sod during installation. Tamp and roll lightly to ensure contact with soil, eliminate air pockets, and form a smooth surface. Work sifted soil or fine sand into minor cracks between pieces of sod; remove excess to avoid smothering sod and adjacent grass.
1. Lay sod across slopes exceeding 1:3.
 2. Anchor sod on slopes exceeding 1:6 with wood pegs or steel staples spaced as recommended by sod manufacturer but not less than two anchors per sod strip to prevent slippage.
- C. Saturate sod with fine water spray within two hours of planting. During first week after planting, water daily or more frequently as necessary to maintain moist soil to a minimum depth of **1-1/2 inches** below sod.

3.8 TURF RENOVATION

- A. Renovate existing turf where indicated.
- B. Renovate turf damaged by Contractor's operations, such as storage of materials or equipment and movement of vehicles.
1. Reestablish turf where settlement or washouts occur or where minor regrading is required.
 2. Install new planting soil as required.
- C. Remove sod and vegetation from diseased or unsatisfactory turf areas; do not bury in soil.
- D. Remove topsoil containing foreign materials, such as oil drippings, fuel spills, stones, gravel, and other construction materials resulting from Contractor's operations, and replace with new planting soil.
- E. Mow, dethatch, core aerate, and rake existing turf.
- F. Remove weeds before seeding. Where weeds are extensive, apply selective herbicides as required. Do not use pre-emergence herbicides.
- G. Remove waste and foreign materials, including weeds, soil cores, grass, vegetation, and turf, and legally dispose of them off Owner's property.
- H. Till stripped, bare, and compacted areas thoroughly to a soil depth of **6 inches**.
- I. Apply as required for new turf.
- J. Water newly planted areas and keep moist until new turf is established.

Weedsport Addition to Maintenance Section and Roof Replacement, MP 304.2

3.9 TURF MAINTENANCE

- A. The Contractor shall maintain turf by watering, fertilizing, weeding, mowing, trimming, as required until satisfactory turf is established.
- B. The Contractor shall roll, regrade, and replant bare or eroded areas and mulch to produce a uniformly smooth turf. Provide materials and installation the same as those used in the original installation if directed by Owner, including:
 - 1. Fill in as necessary soil subsidence that may occur because of settling or other processes. Replace materials and turf damaged or lost in areas of subsidence.
 - 2. In areas where mulch has been disturbed by wind or maintenance operations, add new mulch and anchor as required to prevent displacement.

3.10 SATISFACTORY TURF

- A. Turf installations shall meet the following criteria as determined by Owner's Representative:
 - 1. Satisfactory Seeded Turf: Healthy, uniform, close stand of grass has been established, free of weeds and surface irregularities, with coverage exceeding 90 percent over any 10 sq. ft. and bare spots not exceeding 5 by 5 inches.
 - 2. Satisfactory Sodded Turf: Healthy, well-rooted, even-colored, viable turf has been established, free of weeds, open joints, bare areas, and surface irregularities.
- B. Use specified materials to reestablish turf that does not comply with requirements until turf is satisfactory.

3.11 CLEANUP AND PROTECTION

- A. Promptly remove soil and debris created by turf work from paved areas. Clean wheels of vehicles before leaving site to avoid tracking soil onto roads, walks, or other paved areas.
- B. Remove surplus soil and waste material, including excess subsoil, unsuitable soil, trash, and debris, and legally dispose of them off Owner's property.
- C. Erect temporary fencing or barricades and warning signs as required to protect newly planted areas from traffic. Maintain fencing and barricades throughout initial maintenance period and remove after plantings are established.
- D. Remove nondegradable erosion-control measures after grass establishment period.

END OF SECTION 329200

ITEM 697.0203--25 - FIELD CHANGE ORDER (THRUWAY)**1. DESCRIPTION:**

- 1.01 **General.** The Field Change Order (FCO) provides a contract contingency allowance for the timely payment of authorized additional work that is necessary to fulfill the intent of the plans and specifications.
- 1.02 **Eligible Work.** FCO payments shall be limited to work that is: (1) within the scope of the contract; (2) a quantity variation of existing contract pay items, or; (3) a new contract pay item introduced as a result of minor field adjustments in the details of the project. All eligible items of work shall have a known unit price, either through use of a contract bid price or through an agreed price.

2. MATERIALS:

- 2.01 None specified.

3. CONSTRUCTION DETAILS:

- 3.01 None specified.

4. METHOD OF MEASUREMENT:

- 4.01 This item will be measured for payment on a Dollars Cents basis.
- 4.02 **Bid Price.** The unit price shown in the proposal for this item will be considered as the price bid, and shall not be altered in any manner. Should the amount shown be altered, the new figure will be disregarded and the original bid price will be used to determine the total amount bid for the contract.
- 4.03 **Payments.** Work for which FCO payments are processed will be measured in accordance with the specifications governing the work.

5. BASIS OF PAYMENT:

- 5.01 All work to be paid under the FCO item must be authorized in conformance with §104-02 *Changes, Contingencies, Extra Work and Deductions*. Disputed work, force account work, work associated with §104-10 *Value Engineering Change Proposals*, or payments for time related provisions are not eligible for FCO payment.
- 5.02 FCO payments will be determined from the quantities and unit prices of eligible work that has been completed in conformance with applicable Specifications. Work for which FCO payments are processed will be paid in accordance with the specifications governing the work.
- 5.03 Prior to processing the final agreement, the FCO payments will be reconciled through a final order-on-contract, such that the amount of FCO payments are converted to the corresponding quantities of the pertinent contract pay items. When payments are transferred to the appropriate items, the remaining amount of FCO funds will be deleted.

ITEM 699.04----25 - MOBILIZATION

1. DESCRIPTION:

- 1.01 Under this work the Contractor shall provide the following:
 - A. Necessary bonds, insurance, and prefinancing and set-up of necessary general plant, including shops, storage areas, Engineer’s and Contractor’s offices and such sanitary and other facilities as are required by local or state law or regulation.
 - B. Critical path method (CPM) schedule of operations as described in §108-01 of the TA Addendum.
 - C. M/WBE participation program meeting the M/WBE goals of the contract as described in §109-06 *Contract Payments* and in accordance with §102-12 *D/M/WBE Utilization*.

2. MATERIALS:

- 2.01 Unless otherwise specified, such materials as required for mobilization and are not to be part of the completed contract shall be as determined by the Contractor, except that they shall conform to any pertinent local or state law, regulation or code.

3. CONSTRUCTION DETAILS:

- 3.01 The work required to provide the above facilities and service for mobilization shall be done in a safe and workmanlike manner and shall conform with any pertinent local or state law, regulation or code. Good housekeeping consistent with safety and other requirements of this contract shall be maintained.

4. METHOD OF MEASUREMENT:

- 4.01 Payment for mobilization will be made on a lump sum basis.

5. BASIS OF PAYMENT:

- 5.01 The amount bid for mobilization shall not exceed four percent (4%) of the total contract bid price excluding the bid price for mobilization. Should the bidder exceed the foregoing four percent (4%), the Authority will make the necessary adjustment to determine the total amount bid based on the arithmetically correct proposal.

The amount bid shall include the furnishing and maintaining of services and facilities noted under Section 1.01 to the extent and at the time the Contractor deems them necessary for its operations, consistent with the requirements of this work and the contract.

The amount bid shall be payable to the Contractor with the first contract payment made for other contract work following acceptable completion of all requirements noted under Section 1.01.

Payment will be made under:

<u>Item Number</u>	<u>Item</u>	<u>Pay Unit</u>
699.04----25	Mobilization	Lump Sum

SPECIAL NOTES

CONFIDENTIAL INFORMATION

1. **Confidential Information:** “Confidential Information” means any information not generally known to the public, whether oral or written, that the Authority claims is confidential and discloses to Contractor for the purposes of performing work on the Project. Confidential Information may include, but is not limited to, operational and infrastructure information relating to: bid documents, plans, drawings, specifications, reports, product information and data, business and security processes and procedures; personnel and organizational data, and financial statements; information system IP addresses, passwords, security controls, architectures and designs; and such other data, information and images that the authority deems confidential. The Authority will identify written Confidential Information by marking it with the word “Confidential” and will identify oral Confidential Information as confidential at the time of disclosure to the Contractor.
2. **Exempt Materials:** Confidential Information does not include information which, at the time of the Authority disclosure to Contractor; (a) is already in the public domain or becomes publicly known through no act of Contractor; (b) is already known by Contractor free of any confidentiality obligations; (c) is information that the Authority has approved in writing for disclosure; or (d) is required to be disclosed by Contractor pursuant to law so long as Contractor provides the Authority with notice of such disclosure requirement and an opportunity to defend prior to any such disclosure.
3. **Permitted Use:** Contractor may use Confidential Information solely for the purposes of performing work on the Project. Contractor may share Confidential Information with its employees, consultants, sub-consultants, sub-contractors, suppliers, and agents that are necessary to perform work on the Project (“Authorized Personnel”), but must ensure that such Authorized Personnel execute a Confidentiality and Non-Disclosure Agreement as set forth in the Minimum requirements for the Handling and Treatment of confidential Information. The Authority’s disclosure of Confidential Information to Contractor shall not convey to Contractor any right to or interest in such Confidential Information and the Authority shall retain all right and title to such Confidential Information at all times.
4. **Protections:** Contractor shall hold Confidential Information confidential to the maximum extent permitted by law. Contractor shall safeguard Confidential Information in accordance with the Minimum Requirements for the Handling and Treatment of Confidential Information.
5. **Return of Confidential Information:** Upon the written request of the Authority, Contractor shall return all written Confidential Information to the Authority.

EXTERNAL CONNECTIONS

If in order to perform work on the Project, Contractor must make an external connection to the Authority’s data communications infrastructure and/or access Authority information systems, Contractor shall in all respects comply with all Authority policies and procedures regarding such connections and information systems access and undertake whatever actions are necessary in the discretion of the Authority to ensure such compliance. Contractor shall be responsible for all costs associated with ensuring that its own network security measures comply with all Authority policies and procedures regarding external connections.

**MINIMUM REQUIREMENTS FOR THE
HANDLING AND TREATMENT OF CONFIDENTIAL INFORMATION**

Contractor shall meet the following minimum requirements relative to project information that is identified as **CONFIDENTIAL**.

Authorized Personnel:

Contractor shall require that all authorized individuals or entities (e.g., employees, consultants, sub-consultants, sub-contractors, suppliers and agents) (“Authorized Personnel”) to which it discloses **CONFIDENTIAL** information sign a Confidentiality and Nondisclosure Agreement (“Agreement”). Such Agreement shall provide that Authorized Personnel: are personally responsible at all times for protecting **CONFIDENTIAL** information that is in their possession or control; must always use proper precautions to safeguard against the unauthorized access and disclosure of **CONFIDENTIAL** information; must notify Contractor of any known or suspected instances of loss or theft of, or unauthorized access to, **CONFIDENTIAL** information; and must return all **CONFIDENTIAL** information to Contractor upon completion of the project. Contractor shall be responsible for enforcing the provisions of such Agreement through personal observation and supervision of Authorized Personnel and utilization of appropriate processes.

Contractor shall maintain a list of all Authorized Personnel which have access to **CONFIDENTIAL** information and must provide the Authority with such list upon the Authority’s request. Contractor shall update such list monthly and notify the Authority of any changes in such list.

Inventory Control:

Contractor shall create and maintain an inventory of all **CONFIDENTIAL** information that it provides to Authorized Personnel. Upon completion of the project, Contractor shall check all **CONFIDENTIAL** information returned from Authorized Personnel against the inventory. Contractor shall provide a copy of the checked inventory to the Authority.

Use and Storage:

Contractor shall implement reasonable processes during normal working hours to prohibit unauthorized individuals from gaining access to **CONFIDENTIAL** information that is within the Contractor’s custody and control. At times other than normal working hours, Contractor shall store **CONFIDENTIAL** information in a secure area, such as a fire-proof safe, locked desk, cabinet or other secure storage facility, where access can be controlled. Contractor shall control the access that Authorized Personnel have to **CONFIDENTIAL** information stored in such secure areas through the use of manual or automated locks and keys. Contractor shall maintain a list of Authorized Personnel who have access to such secure areas and the specific **CONFIDENTIAL** information therein.

Reproduction:

Contractor may reproduce **CONFIDENTIAL** information only to the extent necessary to carry out contract performance. Contractor must stamp/mark all **CONFIDENTIAL** information that is reproduced with the word **CONFIDENTIAL** and protect it in the same manner as the original.

Transportation:

To the extent feasible and reasonable, Contractor shall hand deliver **CONFIDENTIAL** information with instructions that only the addressee is allowed to open or view it. Contractor may send **CONFIDENTIAL** information that cannot be hand delivered via the U.S. Postal Service or express mail services (e.g., FEDEX) provided: it is packaged and sealed in a way that does not disclose its contents or the fact that it is **CONFIDENTIAL** information, and a signature from the recipient is required.

Under no circumstances shall a transportation method be used that cannot guarantee that **CONFIDENTIAL** information is accessed only by the intended recipient.

Disposal:

Contractor shall dispose of all **CONFIDENTIAL** information, regardless of its form or format, using a destruction method that prevents its unauthorized retrieval (e.g., crosscut or micro shredding, degaussing).

Loss, Theft or Unauthorized Access:

Contractor shall provide timely notice to the Authority upon discovery of any incident involving the loss or theft of, or unauthorized access to, **CONFIDENTIAL** information.

SPECIAL NOTE:
CONTROL OF MATERIALS

The Contractor's attention is directed to the TA Addendum, Section 106 – CONTROL OF MATERIAL, available from the Authority's website at: <http://www.thruway.ny.gov/business/addendum/index.html>. The Contractor understands and agrees that some or all of the off-site inspection and approval of material such as precast concrete items, structural steel, bridge bearings, concrete structural elements and/or their components to be used on this project will be done by the New York State Department of Transportation (NYSDOT) as the Authority's agent.

The Contractor agrees to the following conditions:

1. Whenever the Contractor receives direction from the NYSDOT regarding the approval/rejection of material that direction constitutes direction by the Authority under the contract and, shall be final and accepted as such by the Contractor.
2. The Contractor will not allow off-site materials subject to inspection and approval of NYSDOT to be shipped to the project site without direct authorization from the NYSDOT.
3. At the Pre-Award Meeting or as soon as practicable, but in any case, before the Pre-Construction Conference, the Contractor will provide the following information to the Thruway Authority's Director, Office of Construction Management, for transmittal to NYSDOT to arrange off-site inspections:
 - A. The name and address of each Manufacturer of all materials, and portions thereof, requiring off-site quality assurance to be incorporated into this highway project.
 - B. The name and address of each Fabricator fabricating each steel item or any portion thereof to be incorporated into this highway project.
 - C. The name and address of each Fabricator manufacturing structural pre-cast/pre-stressed items or any portion thereof to be incorporated into this highway project.
4. The Contractor agrees that it and its Subcontractors and Suppliers will acquire all materials to be incorporated into this Thruway project **only** through Manufacturing, Batching and Fabrication facilities approved by NYSDOT.

AVAILABILITY OF ELECTRONIC BID DATA

1. SUMMARY:

The New York State Thruway Authority (NYSTA) uses Project Bids Software for electronic bidding. Project Bids is a product of the American Association of State Highway and Transportation Officials (AASHTO) that is currently used by the majority of State Departments of Transportation. It is provided free of charge and can be used on almost any Windows-compatible PC. It integrates with many existing electronic bid preparation software and has import/export capability for use with database and spreadsheet systems.

Project Bids allows bidders to receive electronic proposal bid item information from the NYSTA's internet web site and to produce both an electronic and a paper-based bid.

For additional information and downloads, see the NYSTA website at:

<http://www.nysthruway.gov/business/contractors/expedite/index.html>.

2. PARTICIPATION AND RELATIONSHIP TO PAPER DOCUMENTS:

The Authority's adoption of electronic bidding does not force any Contractor to bid electronically. Rather, participation is voluntary. If submitting a bid using infotech's Bid Express internet bidding service, no paper is required. If submitting an electronic bid on a CD, DVD or USB device delivered to the Authority in person or via a courier service, **bidders must also submit print outs that match the electronic file**. Project Bids prints a check code on every bid page that must match the check code in the computer file. As the check code changes every time the electronic file is modified, matching the codes verifies that the data on the printed bid is the same as in the electronic file. **In case of discrepancy, the printouts always prevail and are the primary legal document. Therefore, the printouts can be used to make any last-minute changes.**

3. THIRD-PARTY SOFTWARE:

The NYSTA endorses no particular product but expects all such vendors and individuals to voluntarily keep pace with changes in NYSTA specifications.

4. PROPOSAL NOTES AND CHANGES BY AMENDMENT:

Contractors are solely responsible for recognizing and properly responding to any and all special notes and circumstances printed in the Contract Proposal and any and all changes by amendment from the amendment documents and/or notices communicated to them by the NYSTA's Contracts Unit.

Amendments are posted online at: www.thruway.ny.gov/business/contractors/documents/index.shtml.

Whenever an amendment is issued, a Project Bids amendment file will also be issued and must be applied to your electronic bid. Do not bid without carefully reviewing the printed proposal and any and all changes by amendment. Proposal notes and circumstances include, but are not limited to, printed information on alternate, fixed and/or limited cost items and/or special circumstances regarding item placement and use.

SPECIAL NOTE:**REQUIREMENTS FOR CONTRACTOR'S UTILIZATION OF AREAS
OUTSIDE OF THE RIGHT-OF-WAY**

1. Before the contractor can utilize any area outside of the NYS Thruway Authority (NYSTA) Right of Way (or outside of a temporary easement obtained for the project by the NYSTA), for any work associated with this project, written approval to do so shall be obtained from the NYS Thruway Authority through the Project Engineer. The contractor's request for approval shall be in writing and the Authority shall be allowed 2 weeks to review the request and respond.
2. This requirement applies to areas such as, but not limited to: borrow areas, spoil areas, equipment and/or material storage areas, haul roads, batching areas, water points, shop areas, and all similar areas. This requirement does not apply to the Contractor's established and permanent headquarters, commercial borrow sources, commercial gravel pits, commercial quarries, and all similar areas.
3. The contractor's written request for approval shall include a letter report prepared by an Environmental Professional, acceptable to the Authority, documenting the investigation of the proposed site. The expectation is that an Environmental Professional visits the site, performs an assessment of the proposed use against all applicable environmental requirements, and then documents their findings and recommendations. The letter report shall include the following unless otherwise authorized by the Authority:
 - a) A written description of the activities the contractor wishes to perform at the proposed site, including timeframes.
 - b) Maps showing Federal and State regulated wetlands. The area proposed for use shall be depicted on each map.
 - c) A site location map which accurately shows the area proposed for use, adjacent property boundaries/owners, the location of all wetland boundaries observed, and any required erosion and sediment control measures. If present, wetlands shall be delineated in the field by the Environmental Professional with stakes and ribbon, and wetland delineation data forms shall be completed.
 - d) A written statement prepared by the Environmental Professional regarding the presence of any rare animals or plants or significant natural communities. The Environmental Professional shall use the NYSDEC Environmental Resource Mapper to make this determination. If any rare species are identified, then determine if the rare species are listed as endangered or threatened and whether the NYSDEC determines the proposed use may be harmful to the species or their habitat. If so, address to the satisfaction of the NYSDEC.
 - e) A copy of the applicable SPDES permit and any local municipal permits related to use of the site.
 - f) A listing of other Environmental Permits which were obtained by the Authority for the project. These are referenced in the contract proposal.
 - g) A completed NYSTA Property Release form. The form is available through the Project Engineer.
 - h) A plan showing all restoration work. This includes, but is not limited to, plans for grading, surface restoration details, and erosion and sediment control.
4. This requirement does not waive other provisions of the contract related to use of lands outside the Right of Way. Rather, it shall be viewed as supplementary. The following contract provisions still remain in effect:

§107-08 Protection and Restoration of Property and Landscape, Subsection B. Outside the Right of Way
 §107-10 Managing Surplus Material and Waste

COMPLIANCE WITH SPDES REGULATIONS

The Contractor is advised that the NYS Thruway Authority has evaluated Stormwater requirements for this project and has determined that coverage is not warranted under NYS Department of Environmental Conservation's SPDES General Permit for Stormwater Discharges from Construction Activity (GP-0-20-001). The Contractor shall read and understand the requirements of GP-0-20-001. In the event the Contractor's operations, e.g., clearing and grubbing, expanded staging area; will cause an increase in ground disturbance beyond the amount identified in the Contract Documents, coverage under GP-0-20-001 may be required. Prior to commencing these operations, the Contractor should immediately advise the Project Engineer, who will in turn discuss the request with the Project Designer and Division Environmental Specialist or Environmental Point of Contact.

- In the event coverage is required under GP-0-20-001 as a result of these operations, the Contractor will be required to prepare a Stormwater Pollution Prevention Plan (SWPPP) and submit a Notice of Intent (NOI) with the NYS Department of Environmental Conservation.
- In the event coverage is required under GP-0-20-001 as a result of changes made by the Authority, the Authority will be required to prepare a SWPPP and submit a NOI.

In either case, the Contractor will not be allowed to proceed until verification of coverage under GP-0-20-001 has been provided to the Project Engineer. The Contractor shall make no claim against the Authority for delays resulting from preparing a SWPPP, filing a NOI, and seeking verification of permit coverage.

SPECIAL NOTE**DIESEL EMISSION REDUCTION ACT (DERA) REGULATORY COMPLIANCE**

All New York State Thruway Authority (NYSTA) Contractors are made aware that Environmental Conservation Law (ECL) 19-0323 and the New York State Department of Environmental Conservation (NYSDEC) regulation 6 NYCRR Part 248 *Use of Ultra Low Sulfur Diesel (ULSD) Fuel and Best Available Retrofit Technology (BART) for Heavy Duty Vehicles* requires 100% compliance as of December 31, 2019 of all regulated heavy duty diesel vehicles working on all State awarded contracts. A link to NYSDEC's Part 248 Annual Reporting Requirements which states the current deadlines is located at: <http://www.dec.ny.gov/chemical/118127.html>. NYSTA and its Contractors are responsible for annual reporting.

All NYSTA Contractors shall make determinations of regulatory applicability for vehicles in their inventory used on active NYSTA contracts during each reporting year. These determinations shall be based on the definition of Heavy Duty Vehicle (HDV) including on and off road diesel vehicles having gross vehicle weights in excess of 8,500 pounds, excluding vehicles that are exempt as defined in 6 NYCRR 248-1.1(b)(14). Contractors shall also quantify ULSD fuel used by regulated vehicles in active contract work during the reporting year.

An electronic copy of 6 NYCRR Part 248 can be accessed at <http://www.dec.ny.gov/regs/2492.html>. Electronic copies of the Regulated Entity Vehicle Inventory Form and the Regulated Entity and Contractors Annual Report Form can be accessed under Part 248 – Use of Ultra Low Sulfur Diesel Fuel and Best Available Retrofit Technology for Heavy Duty Vehicles at the following link: www.dec.ny.gov/chemical/4754.html.

To allow for required reports to be submitted to NYSDEC by the regulatory deadline of November 1, each year, NYSTA Contractors shall submit DERA annual reports to NYSTA by October 1, of every year reporting the required information from the previous reporting year (i.e., all 2019/2020 information to NYSTA by October 1, 2020, etc.). The following numbered information shall be submitted:

1. Inclusion of “DERA” and calendar year being reported in subject line of email
2. Contact information including firm name, contact person, phone number and e-mail
3. Estimated annual total quantity of ULSD fuel used by covered vehicles on NYSTA contracts
4. Required Fleet information for covered vehicles on NYSTA contracts

Electronic mail submissions can be sent to dieselreport@thruway.ny.gov

SPECIAL NOTES**GREEN CONSTRUCTION REQUIREMENTS****ULTRA LOW SULFUR DIESEL FUEL**

In order to reduce diesel emissions, the Contractor shall use Ultra Low Sulfur Diesel (ULSD) fuel to operate all diesel engines used to complete the work that will operate for 10 hours or more on the contract site. ULSD fuel requirements shall apply to:

- All diesel engines/equipment.
- Stationary and mobile equipment.
- Owned, leased and rented equipment.

The hours the piece of equipment is used to complete the work is defined as the actual time the engine is running. The time may be continuous or discontinuous and includes warm-up periods idling, in traffic periods, etc.

The Contractor shall correct any non-compliance when any diesel powered construction equipment is in non-compliance. If non-compliance is observed, the Contractor shall correct the non-compliance within a 24-hour period.

SPECIAL NOTES**GREEN CONSTRUCTION REQUIREMENTS****CONTROLLING EXPOSURE TO DIESEL EXHAUST**

The Contractor shall exercise measures to protect “Sensitive Receptors” from the impacts of diesel exhaust fumes. Sensitive Receptors include, but are not limited to: hospitals, schools, daycare facilities, building fresh air or ventilation intakes, elderly housing or convalescent facilities. The Contractor shall ensure that diesel powered engines are located away from building air conditioners and windows.

The goal is to minimize exposure of Sensitive Receptors in close proximity to diesel exhaust, in terms of both concentration and time. In general, close proximity is defined as within 15 meters of a Sensitive Receptor. Mitigation techniques include positioning stationary equipment exhausts greater than 15 meters from Sensitive Receptors, extension of equipment exhausts through the use of flexible tubing; protecting building air intakes; and the use of moving operations.

Idling time for diesel powered equipment shall be limited to three consecutive minutes for delivery and dump trucks and all other diesel powered equipment except as follows:

- When a “mobile source” (vehicle) is forced to remain motionless because of traffic conditions or mechanical difficulties over which the operator has no control.
- When it is necessary to operate a loading, unloading or processing device.
- When the outdoor temperature is less than - 3°C (27°F).
- When the “mobile source” is being repaired.

Arrow panels and portable variable message signs shall be solar powered wherever possible or practical.

Whenever possible and practicable, the Contractor shall establish staging areas for diesel powered vehicles waiting to load or unload materials at the work site. Such areas shall be located where diesel emissions have the least impact on Sensitive Receptors and the general public.

SPECIAL NOTES**GREEN CONSTRUCTION REQUIREMENTS****DUST CONTROL**

The Contractor shall minimize dust from disturbed soil surfaces or other materials that can cause off-site damage, health hazards and traffic safety problems. Dusty conditions resulting from the Contractor's operations shall be corrected at no additional cost to the State. Buffer areas of vegetation should be left where practical. Water quality shall be considered when selecting materials for dust control. An approved dust palliative may be used in conformance with applicable conditions placed on its use. A list of acceptable dust palliatives is available at: www.nysdot.gov/divisions/engineering/technical-services/geotechnical-engineering-bureau/dust-palliatives .

For areas not subject to traffic, products and materials may be applied or placed on soil surfaces to prevent airborne migration of soil particles, including:

- Vegetative Cover –provides the most practical method of dust control.
- Mulch (including rolled erosion control products) –provides a fast, effective method of dust control.
- Spray Adhesives –Generally composed of polymers in a liquid or solid form mixed with water to form an emulsion that is sprayed on the soil surface. The mixing ratios and application rates will be in accordance with the manufacturer’s recommendations for the specific soils on the site. Adhesives shall not be applied to wet soils or if there is a probability of precipitation within 48 hours.

For areas subject to traffic (traveling public or construction traffic) products and materials may be applied or placed on soil surfaces to prevent airborne migration of soil particles, including:

- Water Sprinkling – The site may be sprayed with water until the surface is wet. This is especially effective on haul roads and access routes.
- Polymer Additives –Polymers shall be mixed with water and applied to the driving surface using mixing ratios and application rates in accordance with the manufacturer’s recommendations. No application of the polymer will be made if there is a probability of precipitation within 48 hours of its proposed use. Any polymers must be used in accordance with the NYSDEC issued “Conditions for Use” and “Application Instructions.” This information can be obtained from the NYSDEC website.
- Barriers – Woven geotextiles or stone can be placed on the driving surface to effectively reduce dust throw and particle migration on haul roads.
- Windbreak – A silt fence or similar barrier can control air currents at horizontal intervals equal to ten times the barrier height. Preserve existing vegetation that acts as a wind barrier as much as practical.
- Wheel Washing – Mechanical or manual wet-method cleaning of on-road construction vehicle tires prior to leaving site.

SPECIAL NOTE**GENERATOR KNOWLEDGE FOR DISPOSAL OF TREATED WOOD**

The U.S. Environmental Protection Agency (EPA) and New York State Department of Environmental Conservation (NYSDEC) technique for evaluating whether a material is hazardous for toxicity is the Toxicity Characteristic Leaching Procedure (TCLP). TCLP testing of pentachlorophenol (“penta”) and creosote treated wood by the Electric Power Research Institute, Association of American Railroads, and others has conclusively demonstrated that treated wood products are not a hazardous waste. Under EPA’s and NYSDEC’s rules, such “generator knowledge” can be utilized in place of testing to determine that a waste is not hazardous. This information can be used as evidence that treated wood products can be disposed as non-hazardous waste, based on generator knowledge, in lieu of physical testing.

Generator knowledge information, obtained from the American Wood Preservers Institute (AWPI) can be viewed at their web site located at www.awpi.org. AWPI’s information comes from studies conducted by the Electric Power Research Institute (EPRI), the Washington Public Ports Association (WPPA), and the Association of American Railroads (AAR). EPRI test results are for both penta-treated and creosote-treated wood. WPPA and AAR test results are for creosote-treated wood.

NOTE: Arsenically-treated (*e.g.*, chromated copper arsenate [CCA]) wood products disposed by the end user are exempt from classification as a federal hazardous waste regardless of the TCLP results for specified constituents from any individual sample. Also, wood products treated with preservatives that contain no TCLP constituents (*e.g.*, Kodiak Preserved Wood containing Copper Dimethyldithiocarbamate) are not hazardous waste.

SPECIAL NOTES
FOREST INSECT DISEASE CONTROL

MOVEMENT OF WOOD MATERIALS FROM PROJECT SITES

Pursuant to New York State Department of Environmental Conservation (NYSDEC) Regulations, 6NYCRR, part 192.5, *Firewood Restrictions to Protect Forests from Invasive Species*, it is unlawful to transport any firewood material more than 50 miles from its point of origin to limit the spread of invasive insect species. “Firewood” shall mean all wood of any species, cut or not cut, split or not split, regardless of length which is (a) in a form and size appropriate for use as a fuel, or (b) which is destined for use as a fuel. Firewood shall not include kiln-dried dimensional lumber, wood that has been chipped to a maximum piece size that is no greater than 1-inch in two dimensions, or logs or wood being transported to sawmills or other manufacturing facilities for use in their primary operations. All Thruway Authority (TA) projects are subject to this requirement. Additional information can be found at the following link: <http://www.dec.ny.gov/regs/4079.html>

If firewood is to be moved within 50 miles of its point of origin a “Self-Issued Certificate of Origin for Transport and Possession of Untreated Firewood” must be completed. This form can be found at the following link: http://www.dec.ny.gov/docs/lands_forests_pdf/selfisscert.pdf

INVASIVE SPECIES AND QUARANTINE MATERIALS MOVEMENT

NYSDEC Regulations, 6NYCRR, part 192.6, *Quarantine Orders*, No person shall fail to comply with the provisions of any quarantine order issued by the Department pursuant to Environmental Conservation Law (ECL) section 9-1303. To the extent the provisions of section 192.5 *Firewood Restrictions to Protect Forests from Invasive Species* and such quarantine order are in conflict, the more restrictive provision shall apply. TA is under New York State and Federal ash quarantines where it is unlawful to transport any ash material outside of several counties (see quarantine maps at http://www.agriculture.ny.gov/PI/eab/emerald_ash_borer_quarantine.pdf and <http://www.dec.ny.gov/animals/47761.html>). Therefore, any parts of ash trees, including leaves, bark, stumps, limbs, branches, roots, and ash logs of any length, and firewood (see above for definition of firewood) from ANY tree species, are all considered regulated articles and must be handled properly. Tree-felling, clearing and grubbing operations at project sites may result in the contractor’s need to handle materials from ash tree species and/or firewood or chips from ANY tree species. To the greatest extent possible in areas of clearing and grubbing, ash trees should be pre-identified and marked prior to commencement of construction to promote the proper handling of these materials.

Un-infested ash materials in any form may be moved offsite, but only within the quarantine zone. Firewood from ANY tree species may never be moved more than 50 miles and never from the quarantine area, into non-quarantine areas. Transport of any wood needs the required transport certificate: http://www.dec.ny.gov/docs/lands_forests_pdf/selfisscert.pdf

Note: According to the quarantine maps, several parts of the Thruway are the boundary between the quarantine area (south) and the non-quarantine area (north). Therefore, transport of any wood material would be prohibited across the roadway from south to north, but acceptable from north to south.

Note: Any ash materials that are known or suspected to be infested with live emerald ash borer pests in any life stage must be reported immediately to the EIC and/or designee for further appropriate action and coordination with regulatory agencies.

SPECIAL NOTES
FOREST INSECT DISEASE CONTROL

Any ash materials chipped to a size no greater than 1-inch in at least two dimensions is considered safe to be transported outside the quarantine zone, but only in accordance with a Chip/Mulch Agreement and Transport Agreement received from the NYS Department of Agriculture and Markets (NYSDAM). If any regulated ash materials must be moved outside of the currently quarantined area, a certification from the NYS Department of Agriculture and Markets (NYSDAM) or USDA Animal & Plant Health Inspection Service (APHIS) must be obtained. For further information see the following links:

<http://www.dec.ny.gov/animals/47761.html>

<http://www.agriculture.ny.gov/PI/eab.html>

MARKER RELOCATION DURING CONSTRUCTION
EXISTING MILE MARKERS AND TENTH-MILE MARKERS AND DELINEATORS

All Mile Markers and Tenth-Mile Markers are to be maintained during construction of this project. The Contractor will be allowed to temporarily relocate them to avoid damage to them or for constructability purposes. The Mile Markers and Tenth-Mile Markers can be moved but the new location must be visible to traffic and be reasonably close to their original location. The Mile Markers must be returned to their original location upon completion of construction at that location. Cost for this work shall be included in the bid price for the various pay items in the Project, unless the work is specifically called for in the Contract Documents.

If the Contract calls for replacement of existing Milemarkers and/or Tenth-Milemarkers, they shall remain in place, or reset to a location reasonably close to their original location, until the new markers are installed.

SPECIAL NOTE**BIRD / BAT WASTE AWARENESS**

The Contractor should be aware that there may be bird/bat waste in the work area. The waste may contain trace amounts of metals and the fungus *Histoplasma capsulatum*. Exposure to this fungus can result in the disease histoplasmosis. Proper health and safety precautions shall be identified in the contractor's health and safety plan in accordance with section 107-05. The disposal facility that accepts the bird/bat waste may need documentation as to its composition to determine that it is non-hazardous and/or otherwise suitable for disposal at that location.

SPECIAL NOTE**ASBESTOS CONTAINING MATERIAL (ACM) WITH REMEDIATION**

Asbestos-Containing Material (ACM) is present on this project and shall require disturbing, handling and disposal by the Certified Asbestos Contractor. ACM is identified on the project at the following locations:

- *Caulking Around Exterior Windows (Chrysotile)*
- *Exterior Duct Seal (Chrysotile)*
- *Caulking Around Edge of Roof (Chrysotile)*

The Asbestos Survey report included in the project documents details these identified ACM locations. The reported asbestos quantities are estimates and represent only an approximation for the convenience of the Contractor in estimating the overall extent of asbestos removal required. Appropriate items from Section 210 of the Standard Specification have been included for payment of the asbestos work.

Certifications: All employees involved in the removal or disturbance of any ACM shall be properly and appropriately certified in accordance with 12 NYCRR 56 (N.Y.S. Department of Labor industrial code rule 56). This includes all individuals involved in all portions of the work involving ACM including managing, supervising, designing, inspecting or performing the work.

Work Performance: All work consisting of the removal and disposal of ACM shall be planned for and performed by the Contractor in accordance with Section 210 of NYS Department of Transportation Standard Specifications, 12 NYCRR 56, and where applicable Blanket Variance 14 (BV14), Asbestos-Containing Non-Friable Materials on Bridges, Right-of-Way and Highways. The Contractor shall provide the Thruway Project Engineer with two (2) complete sets of record documents including chain-of-custody records, worker sign in/out sheets, proof of worker certifications, results of any daily monitoring, project monitor daily logs and visual inspection reports and any other such records as requested or as required by regulation and specifications.

When BV14 is applicable and appropriate for use, the Contractor shall note that BV14 assumes that ACM to be abated from bridges is in a non-friable state. Should this ACM be found in the field to have been made friable either by weathering/mechanical action or by the Contractor's activities during abatement, the Contractor shall handle and dispose of the material as asbestos waste and not as construction and demolition (C&D) debris.

Compliance Air Monitoring: The Authority will provide a Project Monitor to monitor and provide final acceptance of the asbestos abatement project, and conduct all compliance air monitoring. The Contractor will need to notify the Thruway Project Engineer two weeks prior to the start of asbestos removal to make arrangements for project monitoring.

Compliance Requirements and Procedures

*For Participation of
Disadvantaged/Minority/Women/Service-Disabled Veteran-Owned
Business Enterprises
and
Equal Employment Opportunity
on
NYS Thruway Authority Contracts*

(DBE/MWBE/SDVOB/EEO)

CONTRACT GOALS FOR DBE/MWBE/SDVOB PARTICIPATION

The New York State Thruway Authority herein after, (“Authority”) is committed to providing and ensuring Minority-owned Business Enterprises (MBE), Women-owned Business Enterprises, (WBE) Service-Disabled Veteran-owned Business Enterprises (SDVOB) and Disadvantaged Business Enterprises (DBE) with opportunities to participate in the Authority’s contracting and procurement processes in accordance with Title 49, Part 26 of the United States Code of Federal Regulations (CFR), New York State Executive Law, Articles 15-A, 17-B, and all applicable federal and state laws, rules, regulations and Executive Orders, including but not limited to Executive Order 177 - Prohibiting State Contracts with Entities that Support Discrimination, as incorporated herein and/or contained in the NYS Department of Transportation Standard Specifications Section 102, “Bidding Requirements and Conditions” to the extent applicable to the contract.

Goal(s) have been established for this Contract/Agreement, expressed as a percentage of the total Contract/Agreement amount as follows:

Disadvantaged Business Enterprise - DBE (Federal-Aid)

Disadvantaged Business Enterprise (DBE) Participation Goal: _____%

Directories and/or Information related to the current certification status of Disadvantaged Business Enterprises can be obtained from the New York State Certified DBEs website at: <https://nysucp.newnycontracts.com>

Minority/Women-Owned Business Enterprise - MWBEs (Non Federal-Aid)

Minority Business Enterprise (MBE) Participation Goal _____ 15 %

Women's Business Enterprise (WBE) Participation Goal _____ 15 %

Directories and/or information related to the current certification status of Minority/Women Business Enterprises can be obtained from the New York State Certified MWBE website at: <ny.newnycontracts.com>

Service-Disabled Veteran-Owned Business Enterprise (SDVOB)

Service-Disabled Veteran-Owned Business Participation Goal _____ 6 %

Directories and/or information related to the current certification status of Service-Disabled Veteran Business Enterprises can be obtained from the New York State Certified SDVOB website at: <ogs.nv.gov/veterans/>

Equal Employment Opportunity

Minority _____ 2.5 %

Female _____ 6.9 %

For more information about the development of the goals, see Federal Register, Vol. 45, No. 194, at 65976-65991 (October 3, 1980) (minorities) and Federal Register, Vol. 45, No. 251 at 85750-85751 (December 30, 1980) (females). The text of these Federal Register notices can be found: • Federal Register Notice: Vol. 45, No. 194, at 65976-65991 (October 3, 1980)

Training Special Provisions _____√ Yes _____ No

Training/Special Provision supplements each of the foregoing prescribed specific Equal Employment Opportunity percentage goals for utilization of minorities and women in the performance of work for the geographic location of the contract, included in this Proposal entitled “Equal Employment Opportunity (EEO) Requirements.”

CHART A

GOALS FOR MINORITY PARTICIPATION

County	%	County	%	County	%
Albany	3.2	Herkimer	2.1	* Richmond	
Allegany.....	6.3	Jefferson	2.5	Rockland	22.6
Broome	1.1	* Kings		St. Lawrence	2.5
* Bronx		Lewis	2.5	Saratoga	3.2
Cattaraugus	6.3	Livingston	5.3	Schenectady	3.2
Cayuga	2.5	Madison	3.8	Schoharie	2.6
Chautauqua	6.3	Monroe	5.3	Schuyler	1.2
Chemung	2.2	Montgomery	3.2	Seneca	5.9
Chenango	1.2	Nassau	5.8	Steuben	1.2
Clinton	2.6	* New York		Suffolk	5.8
Columbia	2.6	Niagara	7.7	Sullivan	17.0
Cortland	2.5	Oneida	2.1	Tioga	1.1
Delaware	1.2	Onondaga	3.8	Tompkins	1.2
Dutchess	6.4	Ontario	5.3	Ulster	17.0
Erie	7.7	Orange	17.0	Warren	2.6
Essex	2.6	Orleans	5.3	Washington	2.6
Franklin	2.5	Oswego	3.8	Wayne	5.3
Fulton	2.6	Otsego	1.2	Westchester	22.6
Genesee	5.9	Putnam	22.6	Wyoming	6.3
Greene	2.6	* Queens		Yates	5.9
Hamilton	2.6	Rensselaer	3.2		

* The following goal ranges are applicable to the indicated trades in the Counties of Bronx, Kings, New York, Queens and Richmond.

Electricians.....	9.0 to 10.2	Bricklayers.....	13.4 to 15.5
Carpenters	27.6 to 32.0	Asbestos workers.....	22.8 to 28.0
Steam fitters	12.2 to 13.5	Roofers	6.3 to 7.5
Metal lathers.....	24.6 to 25.6	Iron workers (ornamental).....	22.4 to 23.0
Painters.....	26.0 to 28.6	Cement masons.....	23.0 to 27.0
Operating engineers	25.6 to 26.0	Glaziers.....	16.0 to 20.0
Plumbers	12.0 to 14.5	Plasterers	15.8 to 18.0
Iron workers (structural)	25.9 to 32.0	Teamsters.....	22.0 to 22.5
Elevator constructors	5.5 to 6.5	Boilermakers	13.0 to 15.5
		All others	16.4 to 17.5

GOALS FOR FEMALE PARTICIPATION

Goal _____ 6.9%

COMPLIANCE REQUIREMENTS AND PROCEDURES

It is the policy of the New York State Thruway Authority (“Authority”) to comply with the provisions of Article 15-A of the New York State Executive Law, which requires that every contract over \$25,000 will afford equality of economic opportunities for minority group members and women, the facilitation of participation by minority-owned business enterprises and women-owned business enterprises. The Authority shall establish separate goals for participation of certified minority-owned business enterprises and women-owned business enterprises on all Authority contracts where applicable.

In addition, it is the policy of the Authority to ensure participation of DBEs on Federal-Aid contracts, pursuant to the provisions of Title 49, Part 26 of the United States Code of Federal Regulations.

Article 17-B of the New York State Executive Law provides for more meaningful participation in public procurement by certified Service-Disabled Veteran-Owned Business Enterprises (“SDVOBs”); thereby further integrating such businesses into New York State’s economy. The Authority recognizes the need to promote the employment of service-disabled veterans and to ensure that certified SDVOBs have opportunities for maximum feasible participation in the performance of Authority contracts.

The Authority is further committed to providing equal training and employment opportunities to minorities and women to participate in the Authority’s contracting and procurement processes, and by ensuring nondiscrimination in accordance with Appendix A - Standard Clauses for New York State Thruway Authority Contracts, including Clause 4 – Non-Discrimination Requirements, Clause 11 - Equal Employment Opportunities for Minorities and Women, Executive Order 11246, Executive Order 177, Training/Special Provisions and/or all applicable, federal, state, laws, rules, regulations and Executive Orders.

1. GENERAL PROVISIONS

- A. The Contractor and/or all subcontractors/subconsultants, shall comply with the applicable laws, rules, regulations and provisions governed by this Contract/Agreement, in addition to any nondiscrimination or diversity practices and provisions of the Contract/Agreement at no additional cost to Authority.
- B. These provisions and requirements shall be included in all subcontracting/subconsultant contracts/agreements so that these requirements and provisions shall be binding upon all subcontractors/subconsultants, performing work under this Contract/Agreement.
- C. The Contractor/Consultant represents and warrants that, as a condition for award of the Contract, the Contractor/Consultant has submitted a Statewide Utilization Management Plan (“SUMP”) via the NYS Contract System (NYSCS) if required by Authority, which lists all proposed Subcontractors/ subconsultants including an identification of the NYS certified DBE/MWBE/SDVOB subcontractors/subconsultants/ suppliers the Contractor/Consultant intends to use to perform the Work of the Contract and to achieve the DBE/MWBE/SDVOB Contract Goals established in the Contract Documents. In addition, or alternatively, Contractor/Consultant may have submitted a request for a waiver. Prior to award of the Contract, the Authority approved Contractor’s/Consultant’s plan to achieve the DBE/MWBE/SDVOB Contract Goals established in the Contract Documents (DBE/MWBE/SDVOB Utilization Plan) to the extent the Authority did not approve Contractor’s/Consultant’s request for a waiver of part or all of the DBE/MWBE/SDVOB Contract Goals. The Authority approval of the DBE/MWBE/SDVOB Utilization Plan approves a Subcontractor/Subconsultant only for the purpose of the DBE/MWBE/SDVOB Utilization Plan.

MBE PROVISIONS FOR NON-FEDERAL AID CONTRACTS AND AGREEMENTS**2. MINORITY/WOMEN-OWNED BUSINESS ENTERPRISES (MWBEs)**

In accordance with Article 15-A of the Executive Law, including regulations promulgated thereunder, the Authority has established the Minority-Owned Business Enterprise (“MBE”) and/or Women-Owned Business Enterprise (“WBE”) participation goals for this Contract/Agreement.. Contractor shall facilitate MWBE participation for the scopes of work to be performed under this Contract/Agreement, to satisfy the participation goals, or document good faith efforts taken to fulfill the goals in a manner prescribed by the Authority in accordance with the Compliance Requirements and Procedures specified herein.

The goals are applicable to the total amount payable under any Contract/Agreement awarded from this procurement and any changes made to the Contract/Agreement.

1. The Authority establishes MWBE goals for all applicable contracts. The MWBE goals for this Contract/Agreement are located on the “Contract Goals” page of this document and can also be found in the contractors/consultants documents for this Contract/Agreement.
2. For purposes of providing meaningful participation to certified MWBEs on this Contract/Agreement and in an effort to attain the certified MWBEs contract goals identified for this Contract/Agreement, the Contractor should reference the directory of MWBEs at the following internet address: ny.newnycontracts.com.
3. The Contractor understands that only sums paid to MWBEs for the performance of a Commercially Useful Function, as that term is defined in 5 NYCRR § 140.1, may be applied towards the achievement of the applicable MWBE participation goal.

In the performance of this Contract/Agreement, the monetary value of fees, or markup percentage, charged by the MWBE shall be deemed to represent the Commercially Useful Function of the MWBE serving as a broker.

4. The Contractor agrees to provide, upon request by the Authority, documentation and/or evidence of actions taken to demonstrate “Good Faith Efforts,” in accordance with 5 NYCRR § 142.8, to provide meaningful participation by MWBEs as subcontractors and suppliers in the performance of this Contract/Agreement.

3. MWBE UTILIZATION REQUIREMENTS

The Contract’s/Agreement’s MWBE goals have been established by the Authority based on certified MWBE availability, job assignments, services to be performed and/or type of work to be performed under the Contract/Agreement.

In the performance of this Contract/Agreement, 60% of the total participation value shall be deemed to represent the Commercially Useful Function of the MWBE serving as a supplier and the mark up and/or broker’s fee shall represent the Commercially Useful Function of the MWBE serving as a broker.

- A. The Contractor shall certify that the Utilization Plan identifies all subcontractors/subconsultants reflected on Exhibit D of the Contract/Agreement.
- B. The Contractor agrees to adhere to the approved MWBE Utilization Plan in the performance of the Contract/Agreement.

- C. The Contractor further agrees that failure to submit and/or adhere to such MWBE Utilization Plan shall constitute a material breach of the terms of the Contract/Agreement. Upon the occurrence of such a material breach, the Authority shall be entitled to any remedy provided herein, including but not limited to, a finding that the Contractor is non-responsible.

Utilization Plan - All Subcontractors (TA-W1022)

4. REPORTING

The Contractor is required to submit forms TA-1023 or TA-W1059 on or before the 10th of each month, following the month being reported. Monthly reports must be submitted via email, to Compliance@thruway.ny.gov, however, during the term of the contract, the Contractor may arrange to provide such reports via a non-electronic method to the Authority by the 10th day following the end of each month during the term of the Contract/Agreement.

TA-W1023 Payments to DBE/MWBE Subcontractor Firms

5. COMPLIANCE

The Contractor will comply with any procedures and guidelines established by the Director of the Division of Minority and Women-Owned Business Enterprise (hereinafter the Director) under the authority of New York State Governor's Executive Order 8, issued August 3, 1983 (hereinafter Executive Order 8) and will comply with any rules, regulations and orders of the Director as may be promulgated pursuant to or under the authority of Executive Order 8, or other applicable law or order.

6. MWBE WAIVERS

- A. Prior to submission of a request for a partial or total waiver, Contractor shall speak to someone from the Authority's Office of Compliance for guidance.
- B. In accordance with 5 NYCRR § 142.7, a Contractor that is able to document good faith efforts to meet the goal requirements, as set forth herein, may submit a request for a partial or total waiver on Form TA-W1077, accompanied by supporting documentation. A Contractor may submit the request for waiver at the same time it submits its MWBE Utilization Plan.

Supporting documentation of good faith efforts shall include, but not be limited to:

1. Evidence of targeted and specific outreach to MWBEs;
2. Logs, written correspondence, records of telephone contacts and other information to document responses from MWBEs to the Contractor outreach;
3. Copies of advertisements for participation by MWBEs in appropriate general circulation, trade, and minority or women-oriented publications;
4. The dates of attendance at any pre-bid, pre-award, or other meetings, if any, scheduled by the Authority with MWBEs; and,

5. Information describing specific steps undertaken by the Contractor to reasonably structure the Agreement's scope of work to maximize opportunities for MWBE participation.
- C. If a request for waiver is submitted with the MWBE Utilization Plan and is not approved by the Authority at that time, the provisions of clauses (C - H) will apply.

If the documentation included with the Contractor waiver request is complete, the Authority shall evaluate the request and issue a written notice of acceptance or denial within 20 business days of receipt.
 - D. Contractor shall attempt to utilize, in good faith, certified MWBEs, during the performance of the Contract/Agreement. Requests for a partial or total waiver of established goal requirements may be made to the Authority, at time of bid/proposal submission, subsequent to award of the Contract/Agreement or at any time during the term of the Contract/Agreement, but must be made no later than prior to the submission of a request for final payment on the Contract/Agreement.
 - E. If the Authority, upon review of the MWBE Utilization Plan and Monthly MWBE Form TA-1023 – Payments to DBE/MWBE/SDVOBs, determines that Contractor is failing or refusing to comply with the Contract's/Agreement's MWBE goals and no waiver has been granted in regards to such non-compliance, the Authority may issue a notice of deficiency to the Contractor.
 - F. The Contractor must respond to the notice of deficiency within seven business days of receipt. Such response may include a request for partial or total waiver of the Contract's/Agreement's MWBE goals.
 - G. If the Contractor, after making good faith efforts, is unable to achieve the MWBE goals stated herein, the Contractor may submit a request for a waiver to the Office of Compliance. Such waiver request must be supported by evidence of the good faith efforts by the Contractor to achieve the maximum feasible MWBE participation towards the applicable MWBE goals. If the documentation included with the waiver request is complete, the Authority shall evaluate the request and issue a written notice of approval or denial within twenty (20) business days of receipt.
 - H. If the Authority, upon review of the MWBE Utilization Plan and the forms TA-W1023 or TA-W1059 as described in Section 4, or any other relevant information, determines that the Contractor is noncompliant, deficient or failing to document the good faith efforts to meet the Contract's/Agreement's MWBE goals or requirements and no waiver has been issued in regards to such non-compliance, the Authority may issue a notice of deficiency to the Contractor. The Contractor must respond to the notice of deficiency letter within seven (7) business days of receipt. Such response may include a request for partial or total waiver of the Contract's/Agreement's MWBE goals.

Waiver requests shall be sent to the Authority's Office of Compliance at Compliance@thruway.ny.gov.

Contractor Forms:

Forms are located at: thruway.ny.gov/business/contractors/forms/index.html

Questions regarding compliance with MWBE participation goals, requirements and provisions should be directed to the Authority's Office of Compliance.

7. NON-COMPLIANCE

- A. Where the Authority determines that the Contractor is not in compliance with the requirements specified herein and/or other contract requirements, refuses to comply with such requirements, or if the Contractor is found to have willfully and intentionally failed to comply with the MWBE participation goals, the Contractor may be found in breach of the contract, which may result in withholding of any mobilization pay item and monthly estimates, a delay in award of the Contract/Agreement, a finding that the Contractor is non-responsible, and/or the Authority may impose liquidated damages.
- B. Such liquidated damages shall be calculated as an amount equaling the difference between:
 1. All sums identified for payment to MWBEs had the Contractor achieved the contractual MWBE goals; and
 2. All sums actually paid to MWBEs for work performed or materials supplied under the Contract/Agreement.
- C. In the event a determination has been made by the Authority, after Contractor has been afforded due process, which requires the payment of liquidated damages, Contractor shall pay such liquidated damages to the Authority within sixty (60) days after such determination or the Authority shall have the ability to withhold such amount from Contractor unless prior to the expiration of such sixtieth day, the Contractor has filed a complaint with the Director of the Division of Minority and Women's Business Development pursuant to 5 NYCRR § 142.12, in which event the liquidated damages shall be payable or withheld from the Contractor only in the event of a determination adverse to the Contractor following the complaint process.

SERVICE-DISABLED VETERAN-OWNED BUSINESS ENTERPRISES (SDVOB)

Article 17-B of the New York State Executive Law provides for meaningful participation in public procurement by certified Service-Disabled Veteran-Owned Business Enterprises ("SDVOB"), thereby further integrating such businesses into New York State's economy. The Authority recognizes the need to ensure that certified SDVOBs have opportunities for maximum feasible participation in the performance of Authority contracts. In recognition of the service and sacrifices made by service-disabled veterans and in recognition of their economic activity in doing business in New York State, Contractor is required to foster participation of SDVOBs in the fulfillment of the requirements of the Contract/Agreement.

In accordance with Article 17-b of the Executive Law, including regulations promulgated thereunder, the Authority has established the SDVOB participation goals for this Contract/Agreement, set forth in the "Contract Goals" page of this agreement.

Contractor shall facilitate SDVOB participation for the scopes of work to be performed under this Contract/Agreement, and/or document good faith efforts taken to achieve the goals in a manner prescribed by the Authority in accordance with the Compliance Requirements and Procedures specified herein.

1. SDVOB GOALS

The goals are applicable to the total amount payable under this Contract/Agreement and any changes made to the Contract/Agreement.

1. The Authority establishes SDVOB goals for all applicable contracts/agreements. The SDVOB goals for this Contract/Agreement are located on the "Contract Goals" page of this document and can also be found in the procurement documents pertaining to this Contract/Agreement.
2. For purposes of providing meaningful participation to certified SDVOBs on this Contract/Agreement and in an effort to attain the certified SDVOB goals for this Contract/Agreement, the Contractor should reference the directory of SDVOBs at the following internet address: online.ogs.ny.gov/SDVOB/search
3. Contractor must document "Good Faith Efforts" to provide meaningful participation by SDVOBs as subcontractors or suppliers in the performance of the Contract/Agreement (see clause 4 below).

2. SDVOB UTILIZATION PLANS

A. In accordance with 9 NYCRR § 252.2(i), Bidders/Proposers are required to submit a completed SDVOB Utilization Plan on Form TA-W1022 within 10 business days of letting.

B. The Utilization Plan shall list the certified SDVOBs that the Contractor intends to use to perform work on the Contract/Agreement, a description of the work that the Contractor intends the SDVOB to perform to meet the goals on the Contract/Agreement, the estimated dollar amounts to be paid to a certified SDVOB, or, if not known, an estimate of the percentage of Contract/Agreement work the SDVOB will perform. By signing the Utilization Plan, the Contractor acknowledges that making false representations or providing information that shows a lack of good faith as part of, or in conjunction with, the submission of a Utilization Plan is prohibited by law and may result in penalties including, but not limited to, termination of a

contract for cause, loss of eligibility to submit future bids, and/or withholding of payments. Any modifications or changes to the agreed participation by SDVOBs after the award of the Contract/Agreement and during the term of the Contract/Agreement must be reported on a revised Utilization Plan and submitted to the Authority's Chief Compliance Officer for approval.

C. The Authority will review the submitted SDVOB Utilization Plan and advise the Contractor of the Authority's acceptance or issue a notice of deficiency within 20 business days of receipt.

D. If a notice of deficiency is issued, Contractor agrees that it shall respond to the notice of deficiency, within seven business days of receipt, by submitting to the Authority a written remedy in response to the notice of deficiency. If the written remedy that is submitted is not timely or is found by the Authority to be inadequate, the Authority shall notify the Contractor and direct the Contractor to submit, within five business days of notification by the Authority, a request for a partial or total waiver of SDVOB participation goals on Form TA-W1077 Contractor/Consultant Waiver Request. Failure to file the waiver request form in a timely manner may be grounds for disqualification of the bid or proposal.

E. The Authority may disqualify a Contractor's bid/proposal/letter of interest as being non responsive under the following circumstances:

- (a) If a Contractor fails to submit a SDVOB Utilization Plan;
- (b) If a Contractor fails to submit a written remedy to a notice of deficiency;
- (c) If a Contractor fails to submit a request for waiver; or
- (d) If the Authority determines that the Contractor has failed to document and/or demonstrate good faith efforts.

F. If Contractor is awarded a Contract/Agreement, Contractor certifies that it will follow the submitted SDVOB Utilization Plan for the performance of SDVOBs on the Contract/Agreement in accordance with the prescribed SDVOB compliance requirements and procedures for the Contract/Agreement goals set forth in this agreement.

G. Contractor further agrees that failure to use SDVOBs as agreed in the Utilization Plan shall constitute a material breach of the terms of the Contract/Agreement. Upon the occurrence of such a material breach, the Authority shall be entitled to any remedy provided herein, including but not limited to, a finding of Contractor non-responsibility.

3. SDVOB WAIVER

A. Prior to submission of a request for a partial or total waiver, Contractor shall speak with someone from the Authority's Office of Compliance for guidance.

B. In accordance with 9 NYCRR § 252.2(m), a Contractor that is able to document good faith efforts to meet the goal requirements, as set forth herein, may submit a request for a partial or total waiver on Form TA-W1077, accompanied by supporting documentation. A Contractor may submit the request for waiver at the same time it submits its SDVOB Utilization Plan.

If a request for waiver is submitted with the SDVOB Utilization Plan and is not approved by the Authority at that time, the provisions of clauses 2 (C), (D) & (E) will apply. If the documentation

included with the Contractor's waiver request is complete, the Authority shall evaluate the request and issue a written notice of acceptance or denial within 20 days of receipt.

C. Contractor shall attempt to utilize, in good faith, certified SDVOBs, during the performance of the Contract/Agreement. Requests for a partial or total waiver of established goal requirements may be made to the Authority, at time of bid submission, subsequent to Contract/Agreement award or at any time during the term of the Contract/Agreement, but must be made no later than prior to the submission of a request for final payment on the Contract/Agreement.

D. If the Authority, upon review of the SDVOB Utilization Plan and Monthly SDVOB Form TA-1023 Payments to DBE/MWBE/SDVOBs determines that Contractor is failing or refusing to comply with the contract goals and no waiver has been granted in regards to such non-compliance, the Authority may issue a notice of deficiency to the Contractor.

The Contractor must respond to the notice of deficiency within seven business days of receipt. Such response may include a request for partial or total waiver of the Contract/Agreement SDVOB goals.

Waiver requests shall be sent to the Authority's Office of Compliance at Compliance@thruway.ny.gov.

4. GOOD FAITH EFFORTS

In accordance with 9 NYCRR § 252.2(n), Contractor must document their good faith efforts toward utilizing SDVOBs on the Contract/Agreement. Evidence of required good faith efforts shall include, but not be limited to, the following:

- (1) Copies of solicitations to SDVOBs and any responses thereto.
- (2) Explanation of the specific reasons each SDVOB that responded to Contractor's solicitation was not selected.
- (3) Dates of any pre-bid, pre-award or other meetings attended by Contractor, if any, scheduled by the Authority with certified SDVOBs which the Authority determined were capable of fulfilling the SDVOB goals set in the Contract/Agreement.
- (4) Information describing the specific steps undertaken to reasonably structure the Contract/Agreement scope of work for the purpose of subcontracting with, or obtaining supplies from, certified SDVOBs.
- (5) Other information deemed relevant to the waiver request.

5. MONTHLY SDVOB CONTRACTOR COMPLIANCE REPORT

In accordance with 9 NYCRR § 252.2(q), Contractor is required to report Monthly SDVOB Contractor Compliance to the Authority during the term of the Contract/Agreement for the preceding month's activity, documenting progress made towards achieving the Contract/Agreement SDVOB goals.

This information must be submitted by the Contractor, using Form TA-1023 Payments to DBE/MWBE/SDVOBs available on the Authority's website, reflecting the preceding month's activities. Timely, complete and accurate forms must be submitted to

Compliance@thruway.ny.gov, by the 10th day of each month, with a courtesy copy to Thruway Project Engineer (TPE)/Engineer in Charge (EIC).

6. NON-COMPLIANCE

Where the Authority determines that the Contractor is not in compliance with the requirements specified herein and/or other contract requirements, refuses to comply with such requirements, or if the Contractor is found to have willfully and intentionally failed to comply with the SDVOB participation goals, the Contractor may be found in breach of the contract, which may result in withholding of any mobilization pay item and monthly estimates, a delay in award of the Contract/Agreement, a finding that the Contractor is non-responsible, and/or the Authority may impose other breach of contract damages.

7. BREACH OF CONTRACT AND DAMAGES

In accordance with 9 NYCRR § 252.2(s), any Contractor found to have willfully and intentionally failed to comply with the SDVOB participation goals set forth in the Contract/Agreement, shall be found to have breached the Contract/Agreement and Contractor shall pay damages equivalent to the Authority's expenses for personnel, supplies and overhead related to establishing, monitoring, and reviewing certified Service-Disabled Veteran-Owned Business Enterprise programmatic goals for the specific Contract/Agreement.

Questions regarding compliance with SDVOB participation goals should be directed to the Authority's Office of Compliance.

All forms are available at:

For Contractors: thruway.ny.gov/business/contractors/forms/index.html

For Consultants: thruway.ny.gov/business/consultants/forms/index.html

For Purchasers: thruway.ny.gov/business/consultants/forms/index.html

EQUAL EMPLOYMENT OPPORTUNITY AND REMOVAL OF INSTITUTIONAL POLICIES OR PRACTICES THAT FAIL TO ADDRESS THE HARASSMENT AND DISCRIMINATION OF INDIVIDUALS

Contractor agrees to comply with all Authority Compliance Requirements and Procedures, in accordance with the terms and conditions of Appendix A – Standard Clauses for New York State Thruway Authority Contracts including Clause 4 – Non-Discrimination Requirements and Clause 11 - Equal Employment Opportunities for Minorities and Women.

Equal Employment Opportunities for minority group members and women (“EEO”) and related provisions shall be deemed supplementary to, and not in lieu of, the nondiscrimination provisions required by New York State Executive Law Article 15 (the “Human Rights Law”) and other applicable federal, state, and local laws.

In the performance of this Contract/Agreement, Contractor shall demonstrate compliance with the Work Force Diversity Requirements and Procedures Regarding Equal Employment Opportunities for Minority Group Members and Women, pursuant to 5 NYCRR § 143, Executive Order 177, and all other applicable federal, state and local laws, rules and regulations.

The Contractor will be required to submit its written Policy Statement ensuring “Equal Employment Opportunity and Removal of Institutional Policies or Practices That Fail to Address the Harassment and Discrimination of Individuals,” to the Authority within 10 business days after the letting/bid opening.

During the performance of this contract, the Contractor agrees to comply with the Equal Employment Opportunity (EEO) requirements specified herein.

1. DEFINITIONS – As used in these requirements, the following definitions will apply:

A. “Covered Area” means the geographical area described in the solicitation from which this contract resulted or the geographic area within which this contract will be performed.

B. “Authority” means the New York State Thruway Authority.

C. “Executive Director” means the Executive Director of the New York State Thruway Authority, or his/her duly authorized representative.

D. “Office of Compliance” means the Thruway Authority’s Office of Compliance or his/her duly authorized representative.

E. “Employer Identification Number” means the Federal Social Security Number used on the Employer’s Quarterly Federal Tax Return, U.S. Treasury Department form 941.

F. “Minority” includes:

(i) Black (all persons having origins in any of the Black African racial groups not of Hispanic origin);

(ii) Hispanic (a person of Mexican, Puerto Rican, Dominican, Cuban, Central or South American descent of either Indian or Hispanic origin, regardless of race);

(iii) Asian and Pacific Islander (all persons having origins in any of the original peoples of the Far East, Southeast, Asia, the Indian Subcontinent, or the Pacific Islands); and

(iv) American Indian or Alaskan Native (all persons having origins in any of the original peoples of North America and maintaining identifiable tribal affiliations through membership and participation or community identification. Identification may be made by any suitable authority in the community such as an educational institution, religious organization, or a state agency).

2. NON-DISCRIMINATION CLAUSE

The Contractor will ensure equal employment opportunity by not discriminating against any applicant for employment because of race, color, religion, sex, national origin, age, disability, or marital status, regarding, (among other things) the following: upgrading, demotion, transfer, recruitment, recruitment advertising, layoff, termination, rates of pay or other forms of compensation and selection for training, including apprenticeship.

3. MINORITY AND WOMEN EMPLOYMENT GOALS

The Contractor shall make a good faith effort to ensure equal employment opportunity by taking the affirmative action’s set forth in paragraph 5A through P of these requirements. The Bidder’s/Proposer’s/Contractor’s/Consultant’s/Engineer’s success in achieving or bettering the goals set forth on the contract goals page, shall be a substantial factor in any determination of

whether the Contractor has complied with its obligation to ensure equal employment opportunity in the performance of this Contract/Agreement. The goals are expressed as percentages of the total hours of employment and training that the Contractor should reasonably be able to give to female or minority employees in a certain covered area. The hours of minority and female employment and training must be substantially uniform throughout the length of the Contract/Agreement, and in each trade. These goals were established from materials published by the NYS Department of Economic Development based on appropriate workforce, demographic or other relevant data or labor force developed by the Division of Minority & Women's Business Development utilizing the 1990 Census Data.

4. AFFIRMATIVE ACTION STEPS AND NON-FEDERAL TRAINING REQUIREMENTS

The Contractor shall implement affirmative action steps at least as extensive as the following:

A. Ensure and maintain a working environment free of harassment, intimidation, and coercion at all sites, and in all facilities at which the Contractor's employees are assigned to work. The Contractor shall specifically ensure that all foremen, superintendents, and other on-site supervisory personnel are aware of and carry out the Contractor's obligation to maintain such a working environment, with specific attention to minority and female individuals working at such sites or in such facilities.

B. Establish and maintain a current list of minority and female recruitment sources, provide written notification to minority and female recruitment sources and to community organizations when the Contractor or its unions have employment opportunities available, and maintain a record of the organizations' responses.

C. Maintain a current file of the name, address, and telephone number of each minority and female off-the street applicant and minority or female referral from a union, a recruitment source, or community organization and of the action which was taken with respect to each such individual.

If such individual was sent to the union hiring hall for referral and was not referred back to the Contractor by the union, or if referred, not employed by the Contractor, this shall be documented in writing to the Office of Compliance and noted in the file with the reasons therefore, along with whatever additional actions the Contractor may have taken.

D. Provide immediate written notification to the Office of Compliance when the Contractor has information that the union referral process has impeded the Contractor's efforts to meet its obligation.

E. Develop on-the-job training opportunities and/or participation in training programs which expressly include minorities and women, including upgrading programs and apprenticeships and trainee programs relevant to the Contractor's employment needs, especially those programs funded or approved by the United States Department of Labor, the New York State Department of Labor, or the New York State Thruway Authority and appropriate for utilization on New York State Thruway Authority projects. The Contractor shall provide notice of these programs to the sources compiled under 5B. above. If the Contractor fails to develop or participate in such apprentice or training programs, its failure to meet the goal set forth herein will be presumed to be noncompliance with these requirements.

F. Disseminate the Contractor's equal employment opportunity policy by providing notice of the policy to unions and training programs and requesting their cooperation in assisting the Contractor in meeting its equal employment opportunity obligations, by including it in any

policy, annual and collective bargaining agreement, by publicizing it in the company newspaper, annual report, and other similar items, by specific review of the policy with all management personnel and with all minority and female at least once a year, and by posting the Contractor's equal employment opportunity policy on bulletin boards accessible to all employees at each location where work under this contract is performed.

G. Review, at least annually, the Contractor's equal employment opportunity policy and affirmative action obligations under this requirement with all employees having any responsibility for hiring, assignment, layoff, termination, or other employment decision, including specific review of these items with on-site supervisory personnel such as superintendents, general forepersons, etc., prior to the initiation of work at any job site.

A written record shall be made and maintained identifying the time and place of these meetings, persons attending, subject matter discussed, and disposition of the subject matter.

H. Disseminate the Contractor's equal employment opportunity policy externally by including it in any advertising in the news media, specifically including minority and female news media, and providing written notification to, and discussing the Contractor's equal employment opportunity policy with, other Contractors and subcontractors with whom the Contractor does or anticipates doing business.

I. Direct its recruitment efforts, both oral and written, to minority, female, and community organizations, to schools with minority and female students, and to minority and female students, and to minority and female recruitment and training organizations serving the Contractor's recruitment area and employment needs. Not later than one month prior to the date for the acceptance of applications for apprenticeship or other training by any recruitment source, the Contractor shall send written notification to organizations such as the above describing the openings, screening procedures, and tests to be used in the selection process.

J. Encourage present minority and female employees to recruit other minority persons and women and, where reasonable, provide after school, summer, and vacation employment to minority and female youth both on the site and in other areas of the Contractor's workforce.

K. State in all solicitations or advertisements for employees placed by or on behalf of the Contractor that all qualified applicants will receive consideration for employment without regard to race, color, religion, sex, national origin, age, disability, or marital status.

L. Conduct, at least annually, an inventory and evaluation of all minority and female personnel for promotional opportunities and encourage these employees to seek or to prepare for such opportunities through appropriate training or other similar activities.

M. Ensure that seniority practices, job classifications, work assignments, and other personnel practices do not have a discriminatory effect by continually monitoring all personnel and employment related activities to ensure that the equal employment opportunity policy and the Contractor's obligations under this requirement are being carried out.

N. Ensure that all facilities and company activities are non-segregated except that separate or single-user toilet and necessary changing facilities shall be provided to assure privacy between the sexes.

O. Send to each labor union or representative of workers with which the Contractor has a collective bargaining agreement or other contract or understanding, a notice advising the said labor union or workers' representative of the Contractor's commitments under this requirement

and post copies of the notice in conspicuous places available to employees and applicants for employment.

P. Conduct a review, at least annually, of all supervisors' adherence to, and performance under, the Contractor's equal employment opportunity policies and affirmative action obligations.

5. CONTRACTOR/CONSULTANT ASSOCIATIONS

Contractor is encouraged to participate in voluntary associations which assist in fulfilling one or more of their affirmative action obligations. The efforts of a contractor association, joint contractor union, contractor community, or other similar group of which the Contractor is a member and participant, may be asserted as fulfilling one or more of its obligations under this requirement provided that the Contractor actively participates in the group, makes every effort to ensure that the group has a positive impact on the employment of minorities and women in the industry, ensures that the concrete benefits of the program are reflected in the Contractor's minority and female workforce participation, makes a good faith effort to meet its individual goals, and can provide access to documentation which demonstrates the effectiveness of actions taken on behalf of the Contractor. The obligation to comply, however, is the Contractor's and failure of such a group to fulfill an obligation shall not be a defense for the Contractor's noncompliance.

6. TRANSFER OF MINORITY OR FEMALE EMPLOYEES

Through implementing the affirmative action's set forth above and the Contractor's other efforts to ensure equal employment opportunity, the Contractor must have made a commitment to employ minorities and women throughout the life of the contract. The transfer of minority or female employees or trainees from Contractor to Contractor or from project to project for the sole purpose of meeting the Contractor's goals shall be violation of the contract.

7. CREDITING NON-WORKING TRAINING HOURS TOWARD EMPLOYMENT GOALS

In order for the non-working training hours of apprentices and trainees to be counted in meeting the goals, such apprentices and trainees must be employed by the Contractor during the training period, and the Contractor must have made a commitment to employ the apprentices and trainees at the completion of their training, subject to the availability of employment opportunities. Trainees must be trained pursuant to training programs approved by the United States Department of Labor, the New York State Department of Labor or the New York State Thruway Authority and appropriate for utilization on the New York State Thruway Authority projects.

8. REQUIRED RECORDS

A. The Contractor shall designate a responsible official to monitor all employment related activity to ensure that the Contractor's equal employment opportunity policy is being carried out and to keep records. The records shall include the names, address, telephone number, construction trade, union affiliation, if any, employee identification number when assigned, social security number, race, sex, status (e.g. mechanic, apprentice, trainee, helper or laborer), dates of changes in status, hours worked per week in the indicated trade, rate of pay and locations at which the work was performed for each employee.

Records shall be maintained in an understandable and retrievable form. To the extent that records kept by the Contractor for other purposes satisfy the requirements of this paragraph, the Contractor need not maintain separate records.

B. Contractor shall submit on a monthly basis “Monthly Workforce Utilization Composite” (Form TA-W1017) to the TPE/EIC for approval and submitted electronically upon approval to Compliance@thruway.ny.gov. The report shall reflect a monthly composite of the total cumulative hours of work for the entire project workforce (including all subcontractors) from the start of the contract through the contract ending date. For the purpose of composite reporting, the employment and training hours for females and minorities shall be calculated separately. Female utilization hours (minority and non-minority) shall be counted towards female utilization and minority female utilization hours shall also be counted towards minority utilization hours.

C. All records required by this Section must be retained for a period of six years following completion of the contract work and shall be available at reasonable times and places for inspection by authorized representatives of the Authority or the Office of Compliance.

9. GOALS NOT TO BE USED TO DISCRIMINATE

The Contractor shall not use the goals or affirmative action requirements to discriminate against any person because of race, color, religion, sex, national origin, age disability, or marital status.

10. AVAILABILITY OF CONTRACTOR’S RECORDS

The Contractor will furnish all information and reports as may be required by the Authority or by rules, regulations and orders incorporated herein by the Authority and will permit access to its books, records and accounts by the Authority’s Office of Compliance for purposes of monitoring and investigating compliance with these requirements and such rules, regulations, orders, procedures and guidelines.

11. ENFORCEMENT

In order to determine whether the Contractor has complied with the requirements, the Authority may proceed by order to show cause, compliance conference, hearing or any other lawful procedure upon due notice in writing to the Contractor. In the event the Authority finds that the Contractor has failed to comply with these requirements, this contract may be canceled, terminated, or suspended in whole or in part or liquidated damages may be imposed in accordance with the procedures authorized in Section 312 of Executive Law 15-A, Section 40 of the Highway Law, provisions of this Contract/Agreement, relevant laws and statutes as deemed appropriate by the Authority, at no cost or liability to the Authority.

In accordance with EO 177 entitled “Prohibiting State Contracts with Entities that Support Discrimination”, provisions of this Contract/Agreement and Section 40 of the Highway Law, the Contractor may be declared ineligible for further New York State government contract or construction contracts, and such other sanctions may be imposed and remedies invoked as deemed appropriate by the Authority by rule, regulation, or order of the Authority, or as otherwise provided by law.

12. CONTRACTOR’S RESPONSIBILITY REGARDING COLLECTIVE BARGAINING AGREEMENT

Neither the provisions of any collective bargaining agreement, nor the failure by a union with whom the Contractor has a collective bargaining agreement to refer either minorities or women shall excuse the Contractor’s obligations under these requirements, any rules, regulations, procedures and guidelines promulgated or established pursuant to Executive Order 21.

13. APPLICABILITY TO SUBCONTRACT

As per Section 312 of Executive Law 15-A the Contractor will physically include the document Equal Employment Opportunity Requirements as part of every subcontract or purchase order unless exempted by rules, regulations, or orders of the Director, pursuant to the Executive Order 8, and such requirements shall be binding upon each subcontractor, service provider, or vendor. The Contractor will take such action with respect to any subcontract or purchase order as the Authority may direct as a means of enforcing such provisions, including sanctions for

noncompliance; provided, however that in the event the Contractor becomes involved in or is threatened with litigation by a subcontractor or vendor as a result of any provision or direction issued pursuant to these requirements or by the Authority, the Contractor may request the State of New York to enter into such litigation or dispute to protect the interests of the State of New York.

14. EQUAL EMPLOYMENT OPPORTUNITY OFFICER

The Contractor will designate and make known to the Office of Compliance who will have the responsibility for and must be capable of effectively administering and promoting an active Contractor program of equal employment opportunity and who must be assigned adequate authority and responsibility to do so.

15. COMPLAINTS OF ALLEGED DISCRIMINATION/SEXUAL HARASSMENT

The Contractor will promptly investigate all complaints of alleged discrimination/sexual harassment made to the Contractor in connection with his/her obligations under this contract, will attempt to resolve such complaints, and will take appropriate corrective action within a reasonable time. If the investigation indicates that the discrimination/sexual harassment may affect persons other than the complainant, such corrective action shall include such other persons. Upon completion of each investigation, the Contractor will inform every complainant of all of his or her avenues of appeal, including the New York State Division of Human Rights and Equal Employment Opportunity Commission.

The Contractor shall inform the Office of Compliance (within 24 hours) in writing of any formal or informal complaint, incident or any issue of discrimination/sexual harassment. Results of investigation must be submitted to the Office of Compliance within ten (10) days of the complaint.

TRAINING SPECIAL PROVISIONS

TA-1041 – Training Report

TA-1046 – Monthly Training Report

This work shall consist of the employment and meaningful and effective training of minority and women in New York State Thruway Authority approved training programs leading to their qualification as journeyworkers in the skilled trades required in highway construction. This Training/Special Provision supplements the Equal Employment Opportunity requirements included elsewhere in this Proposal entitled “Equal Employment Opportunity (EEO) Requirements”. Each of the foregoing prescribed specific percentage goals for utilization of minorities and women in the performance of work for the geographic location of the contract.

GENERAL: The primary objective of this Training/Special Provision is to provide training opportunities to minorities and women in construction trades for two purposes:

1. To maintain a pool of qualified minorities and women to replace those journeyworkers who, in the natural course of events, will leave the workforce; and
2. To provide minorities and women as indentured apprentices or trainees in those geographic areas where shortages in minorities and women journeyworkers are recognized because of the Contractor's inability to meet the EEO goals set forth in this contract.

Each contract which contains this Training/Special Provision shall require the training of at least one minority or woman indentured apprentice or trainee. Such individual shall be approved by the Authority. Other than this initial training obligation, to be undertaken and provided by the Contractor, no additional training obligations will exist under this Training/Special Provision unless the goals for minority and women employment and training in the skilled workforce are not continuously met on the contract and generally distributed amongst the trades. In the five counties of New York City, the goals specified for each trade are applicable and must be met. Whenever the goals are not met, additional minorities and/or women indentured apprentices and/or trainees will be assigned or approved in numbers necessary to meet the goals. Data necessary to determine if goals are being met will be provided on Contractor and Subcontractor Employment Utilization Reports (Form TA-1017-9). The data will be verified by the visual observance of the Project Engineer, or designated project inspectors, and hours of employment reported on Contractor or Subcontractor certified weekly payrolls.

The number of minorities and women indentured apprentices and trainees required to be trained under this item shall not exceed 12% of the total journeyworker workforce on the contract, i.e. no more than 1 in 8 of the skilled workforce is required to be a minority or woman indentured apprentice or trainee. This limitation applies regardless of minority and women representation in the trades. However, this limit on required training in no way absolves the Contractor of the responsibility to comply with the EEO requirements.

PRE-AWARD MEETING: Before the Contractor will be allowed to begin work, the Contractor shall attend a Pre-award Meeting and shall submit for Authority use and acceptance, a Workforce and Training Utilization Schedule (Form TA-1024) which shall be correlated to the Contractor's contract work schedule. The Schedule shall include at least the following information:

1. A work schedule for the entire contract,
2. An estimate of the work force required to conform to the work schedule on a monthly basis including an estimate of the workforce in each trade and/or work classification projected to be used including Subcontractors,
3. Separate estimates of the number of minorities and women indentured apprentices or trainees that would be required in each skilled trade to meet the contract EEO employment goals for that trade assuming no minorities or women journeyworkers in the workforce,
4. The proposed training programs to be used and the starting dates for training in each trade and/or work classification,
5. An estimate of the availability of minorities and women journeyworkers in numbers sufficient to meet the EEO contract goals, and

6. Any proposal by the Contractor to use trainees or indentured apprentices to make up for anticipated EEO goal shortfalls. Such proposals shall include the name and craft of any individual proposed by the Contractor as the required trainee or indentured apprentice. In the case of an indentured apprentice, evidence of indentureship and registration of the approved apprenticeship program must be included.

No contract work may be undertaken until the Authority has accepted the Workforce and Training Utilization Schedule. The Contractor shall submit a revised Workforce and Training Utilization Schedule at such times as major changes in the contract work schedule occur which substantially affect the previously submitted schedule.

RECRUITMENT: Although the training requirements of this Training/Special Provision are not intended, and shall not be used to discriminate against any applicant for training, whether a member of a protected class or not, it is recognized that non-minority males have traditionally been and continue to be trained, either formally or on-the-job in an informal manner, for work in the trades utilized in construction work. Therefore, until such time that representative numbers of minorities and women complete training and their utilization as journeyworkers is demonstrated to the extent of the participation goals as set forth in the Authority's construction contract, training required under this Training/Special Provisions will be primarily limited to minorities and women.

Thus, the Contractor shall demonstrate compliance with the intent of this Training/Special Provision by affording the Authority the opportunity to:

1. First, approve the use of a minority or woman indentured apprentice known to the Contractor through an existing Joint Apprenticeship Training program, or
2. Second, provide a partially trained minority or woman trainee who is currently enrolled in a New York State Department of Labor approved training program, or
3. Third, work cooperatively with the Contractor in recruitment of new minorities or women trainees, when needed.

In conformance with the foregoing, the Authority's Form TA-1018 (Request for Personnel), should be submitted to the TPE/EIC for submission to the Authority's Office of Compliance. The Contractor shall allow reasonable time for the Authority's Office of Compliance to ensure on-the-job orientation for approved apprentices or assigned trainees within their first month of employment.

WORK HISTORY: No individual shall be employed as a trainee in any trade and/or work classification in which such person has successfully completed a training course providing journeyworker status in the same trade or work classification, or in which such person has been gainfully employed as a journeyworker by virtue of informal on-the-job training. Detection of individuals in the above categories may be accomplished by including appropriate questions on employee application forms, inquiries to the Authority's Office of Compliance, checking personal references, or by other suitable means. Regardless of the method used, the Contractor shall document the finding for each indentured apprentice or trainee provided training under this requirement. A copy of the finding shall be given to the Authority's Office of Compliance. In the case of indentured apprentices, evidence of indentureship in a registered approved apprenticeship program shall also be submitted.

SUBCONTRACTING: In the event the Contractor subcontracts a portion of the contract work, the Contractor shall ensure the requirements of this Training/Special Provision are physically incorporated in such subcontracts to ensure the workforce utilization by the Subcontractor meets the goals for minorities and women employment and training, either independently or in combination with the prime Contractor's workforce. The Contractor must determine the hours of training, if any, and in which trade or work classification, minorities or women indentured apprentices or trainees are to be trained by the Subcontractor(s). However, the Contractor shall retain the primary responsibility for meeting the training requirements of this Training/Special Provision. Subcontractors are herewith advised that disregard of these requirements may result in the Authority either rescinding approval for work on this contract or disapproving their use on subsequent Authority contracts.

TRAINING PROGRAMS: The minimum length, type of training, and rate of pay for the trade or the work classification of the trade will be specified in the training program approved or sanctioned by the New York State Department of Labor.

Where training is to be provided under this Training/Special Provision, the Contractor shall obtain acceptance and/or approval of the training program to be used, and the starting time for training, prior to commencing training. The Contractor shall provide on-the-job training directed toward developing journeyworkers in the trade, or work classification(s) of the trade involved. To the extent the work involved on the contract permits, such training should include all phases and facets of a trade, or work classification of a trade, to satisfy usual construction industry requirements for continued or future employment therein.

It is the intent of this Training/Special Provision that training will be provided in construction trades rather than clerical type positions. Training may be permitted, in unique circumstances, in lower level management positions such as office engineers, where the training is oriented toward construction related activities. Some off-site training is permissible as long as the training is an integral part of an approved training program and does not comprise a significant part of an overall training program. Both off-site and lower level management training are subject to the Authority's approval.

TRAINEE WAGES: An employee on any New York State Public Works Contract must be paid the full journeyworker prevailing wage unless such employee is individually registered in an approved and registered New York State Department of Labor Apprenticeship Program. It is the responsibility of the Contractor to ascertain the status of any employee utilized to satisfy the trainee requirements under this contract, and to ensure that all New York State Department of Labor apprenticeship requirements are met.

Apprentices shall be paid fringe benefits in accordance with the provisions of the apprenticeship program. If the apprenticeship program does not specify fringe benefits, apprentices must be paid the full amount of fringe benefits listed on the wage determination for the applicable classification. Trainees shall be paid fringe benefits in accordance with the provisions of the trainee program. If the trainee program does not mention fringe benefits, trainees shall be paid the full amount of fringe benefits listed on the wage determination unless the Administrator of the Wage and Hour Division determines that there is an apprenticeship program associated with the corresponding journeyworker wage rate on the wage determination which provides for less than full benefits for apprentices.

DURATION OF TRAINING: Once an indentured apprentice is approved or a trainee is assigned to the contract under the Training/Special Provision, that individual shall be trained in the designed trade throughout the duration of the contract whenever such trade is in use on the

contract until the trainee or apprentice has completed the approved training program. Where training is provided under a multiphase apprenticeship or training program, it is expected that training will be provided continually through all phases to the extent that opportunities for such training exist in the work under contract. Upon satisfactory completion of a phase of training under a multiphase training program, if further appropriate and required training is not available and work in the work classification of the completed phase is available, the minority or woman indentured apprentice or trainee shall continue employment, and be compensated at the prevailing journeyworker wage rate for such work. Hours of employment as a journeyworker described above will not be credited toward training hours required by the approved training or apprenticeship program.

If an indentured apprentice or trainee is terminated before completion of the contract for any reason other than seasonal lay-off or completion of work in that trade, the Contractor shall hold a counseling session with the Authority's Chief Compliance Officer and the individual to explain the reasons for termination. Documentation that the counseling session was held and the reasons for termination shall be given to the Authority's Chief Compliance Officer.

REQUIRED RECORDS: The Contractor shall provide each minority or woman trained under this provision with a certification showing the type and length of training satisfactorily completed. In addition, the Contractor shall keep records on the job site indicating the nature and hours of training provided to each trainee or indentured apprentice and furnish weekly reports documenting performance under this Training/Special Provision to the Project Engineer. No measurement will be made of training provided to indentured apprentices or trainees for whom no work history has been provided to the Project Engineer. In addition, no measurement will be made of training provided to apprentices for whom no evidence of indentureship in a registered apprenticeship program has been provided to the Project Engineer.

NO PAYMENT FOR TRAINING: No payment will be made for the training required of the Contractor under this Training/Special Provision. The required training is a labor cost which is included in the lump sum bid by the Contractor for the items of work comprising the contract.

(1) Journeyworker means a person who is capable of performing all the duties within a trade or a given work classification of a trade.

WORKFORCE UTILIZATION/GROSS WAGES REPORTING

In accordance with the requirements pursuant to Executive Order (EO) 162, Contractors must report employee workforce utilization on a monthly basis and gross wages on a quarterly basis for its company and all subcontractors in accordance with EO 162, as follows:

A. EO 162 (Monthly/Quarterly) Workforce Utilization/Gross Wages Reporting

Construction Contractors/Subcontractors are required to submit (Monthly) Workforce Utilization and (Quarterly) Workforce Utilization/Gross Wages Reports for their firm and all subcontractors.

(Monthly) Workforce Utilization/ (Quarterly) Gross Wages Reports are required to be electronically submitted to WorkforceUtilizationReportConstruction@thruway.ny.gov.

(Monthly) Workforce Utilization report for the preceding month must be submitted by the 10th of each month, for the Contractor and all subcontractors.

The (Monthly) EO 162 Workforce Utilization/Gross Wages Reporting are located on the Thruway website @ thruway.ny.gov/business/dmwbe/eo-162-monthly-construction.xls

(Quarterly) - Workforce Utilization, including Gross Wages Reports for quarterly reporting must be submitted by 10th of April, July, October and January, for the Contractor and all subcontractors.

The (Quarterly) EO 162 Workforce Utilization/Gross Wages Reporting are located on the Thruway website @ thruway.ny.gov/business/dmwbe/eo-162-quarterly-construction.xls

B. Form TA-1017 Monthly Workforce Utilization Composite Report

Form TA-1017 (Monthly) Workforce Utilization Composite report must be completed for each calendar month by the Contractor reflecting the cumulative total work hours of employment to date for the entire workforce.

Form TA-1017 (Monthly) - Workforce Utilization Composite Report, must be approved by the TPE/EIC and electronically submitted prior to the 10th of the month to Compliance@thruway.ny.gov.

Form TA-1017 (Monthly) - Workforce Utilization Composite Report is located on the Thruway website @ thruway.ny.gov/business/dmwbe/ta-w1017.xls

NONDISCRIMINATION

The Contractor shall comply with the provisions of the Human Rights Law, and all other state and federal statutory and constitutional non-discrimination provisions. The Contractor and its subcontractors shall not discriminate against any employee or applicant for employment because of race, creed (religion), color, sex, national origin, sexual orientation, military status, age, disability, predisposing genetic characteristic, marital status or domestic violence victim status, and shall also follow the requirements of the Human Rights Law with regard to non-discrimination on the basis of prior criminal conviction and prior arrest.

Questions regarding compliance with Workforce Utilization/Gross Wages Reporting should be directed to the Authority's Office of Compliance.

MOBILIZATION AND PAYMENT OF ESTIMATES/INVOICES

Processing of mobilization, estimates and/or invoices is contingent upon Contractor demonstration and/or documentation of compliance with **all** of the Authority's Disadvantaged Business/Equal Employment Opportunity/Minority/Women and Service-Disabled Veteran Owned-Business Enterprise Contract/Agreement requirements and provisions.

Forms listed herein may be revised, updated, at the Authority's sole discretion and are required during the covered period, under the reporting schedules established by the Authority.

DBE/EEO/MWBE/SDVOB forms, requirements and reporting schedules will be discussed during the pre-award meeting or by contacting the Authority's Office of Compliance.

REPORTING AND SUBMISSION SCHEDULES

Contractors are required to submit the following forms or reports by the 10th of each month, for the preceding month's activities to: Compliance@thruway.ny.gov

TA-W1017 Monthly Workforce Utilization Composite
TA-W1023 Payments to D/M/WBE Subcontracting Firms
TA-1024 Workforce and Training Utilization Schedule
TA-W1046-9 Weekly Training Progress Report

The above forms or reports must accurately reflect the information reported on the following forms:

TA-W1022-9 Utilization Plan
TA-W1024-9 Workforce and Training Utilization Schedule
TA-W1041-9 Training Report
TA-W1064-9 Construction Contractors Annual EEO Report

Contractors are also required to submit the following forms or reports by the 10th of each month, for the preceding month's activities to:

WorkforceUtilizationReportConstruction@thruway.ny.gov

EO 162 - Monthly Workforce Utilization/Gross Wage Report
EO 162 - Workforce Utilization/Quarterly Gross Wage Report

All Authority Forms are available at:

<http://www.thruway.ny.gov/business/contractors/forms/index.html>

Timely, complete and accurate reports shall be submitted as required and/or upon request.

**STATE
WAGE RATE
INFORMATION**

WAGE RATES

The New York State Thruway Authority does not represent or warrant that the accompanying schedule of wages with the classification of workmen, mechanics and laborers, as required by Section 220 of the Labor Law, is complete and it reserves the right to revise such schedule when required.

In the event that revisions are made before the letting date, an amendment will be issued by the Department of purchasers of plans. In the event that the current wage rate schedule should expire before the contract for this project becomes effective the said wage rate schedule will be recertified and the Contractor will be bound by such revised schedule as recertified.

Labor classifications not appearing on this rate sheet can be used only with the consent of the Chief Engineer of the Authority and then the rate to be paid will be given by the Chief Engineer of the Authority after consulting with the State Department of Labor.

All requests for minimum wage rates for additional occupations shall be directed through the Chief Engineer, Thruway Authority.

By legislation effective August 9, 1975, if the prevailing rate of wages or the prevailing practices for supplements as determined by the State Labor Department changes after the contract is let, the Thruway Authority shall request of the State Labor Department a redetermination of the schedules of wages and supplements and such revised wage rates and supplements shall be annexed to and form a part of the contract for the work. The prevailing wage rates and supplemental benefits to be paid are those in effect at the time the work is being performed. The bidder shall take into account in his bid prices all changes in wage rates and supplements that may be forthcoming during the time the contract is in force.

The bidder shall take into account in his bid prices all changes in wage rates and supplements that may be forthcoming during the time the contract is in force.

Pursuant to Section 220-A of the New York State Labor law, the prime Contractor must provide each approved subcontractor with a copy of the schedule of wages and any supplements as specified in this Contract.

The prime Contractor must immediately obtain from each approved subcontractor a certification (TA-44105) of their receipt of, and agreement to pay the applicable prevailing wages as specified in this contract. The prime Contractor shall retain all Subcontractor certifications and provide these certifications to the Authority prior to the processing of the final payment.

The prime Contractor must submit an affidavit (TA-44115) verifying the proper payment of wages to its own employees prior to the processing of the final payment. All completed certifications and affidavits must be originals and be properly signed and notarized.

SPECIAL NOTICE TO BIDDERS IN RELATION TO OVERTIME DISPENSATION

All bidders, in submitting their bids, should base their bids and work progression on the assumption that Overtime Dispensation pursuant to Article 8 of the New York State Labor Law, for any workmen, laborers and mechanics to work more than 8 hours in any one calendar day or more than five days in any one week will not be granted for any operation for the contract duration. Subsequent to award, where the contract documents have imposed specific scheduling and/or phasing requirements or where it is determined by the Authority to be in the best interest of the public, the Authority may process, for approval by the new York State Department of Labor, requests for Overtime Dispensation on certain specific operations and, in the event approval is granted, there shall be no adjustments therefore in any bid prices.

SPECIAL NOTE
STATE PREVAILING WAGE RATES

The Contractor shall ensure that workers are paid the appropriate wages and supplemental (fringe) benefits. Throughout the contract, the Contractor shall obtain and pay workers in accordance with periodic wage rate schedule updates from the NYS Department of Labor (NYSDOL). Wage rate amendments and supplements are available on the NYSDOL web site at www.labor.ny.gov. All changes or clarification of labor classification(s) and applicability of prevailing wage rates shall be obtained in writing from the Office of the Director, NYSDOL Bureau of Public Work.

The NYSDOL prevailing wage rate schedule for this contract has been determined and is available on the internet. The prevailing wage rate schedule is accessed by visiting the NYSDOL web site, navigating to the appropriate web page, and entering the Prevailing Rate Case No. (PRC#). The PRC# is provided on NYSDOL Form PW-200 included in this contract Proposal.

A copy of the project specific prevailing wage rate schedule will be provided to the successful bidder upon award of the contract. Upon written request, the schedule will be provided by the Thruway Authority to prospective bidders without internet access.



Kathy Hochul, Governor

Roberta Reardon, Commissioner

NYS Thruway Authority

Antonio Melendez, Professional Engineer 1
 200 Southern Boulevard
 Albany NY 12209

Schedule Year 2023 through 2024
 Date Requested 12/27/2022
 PRC# 2022013984

Location I-90, Interchange 40, MP 304.2
 Project ID# D214913
 Project Type Addition to the Maintenance Section Building & Roof Replacement at MP 304.2 in Cayuga County in accordance with the Plans and Specifications.

PREVAILING WAGE SCHEDULE FOR ARTICLE 8 PUBLIC WORK PROJECT

Attached is the current schedule(s) of the prevailing wage rates and prevailing hourly supplements for the project referenced above. A unique Prevailing Wage Case Number (PRC#) has been assigned to the schedule(s) for your project.

The schedule is effective from July 2023 through June 2024. All updates, corrections, posted on the 1st business day of each month, and future copies of the annual determination are available on the Department's website www.labor.ny.gov. Updated PDF copies of your schedule can be accessed by entering your assigned PRC# at the proper location on the website.

It is the responsibility of the contracting agency or its agent to annex and make part, the attached schedule, to the specifications for this project, when it is advertised for bids and /or to forward said schedules to the successful bidder(s), immediately upon receipt, in order to insure the proper payment of wages.

Please refer to the "General Provisions of Laws Covering Workers on Public Work Contracts" provided with this schedule, for the specific details relating to other responsibilities of the Department of Jurisdiction.

Upon completion or cancellation of this project, enter the required information and mail **OR** fax this form to the office shown at the bottom of this notice, **OR** fill out the electronic version via the NYSDOL website.

NOTICE OF COMPLETION / CANCELLATION OF PROJECT

Date Completed: _____ Date Cancelled: _____

Name & Title of Representative: _____

Phone: (518) 457-5589 Fax: (518) 485-1870
 W. Averell Harriman State Office Campus, Bldg. 12, Room 130, Albany, NY 12226

General Provisions of Laws Covering Workers on Article 8 Public Work Contracts

Introduction

The Labor Law requires public work contractors and subcontractors to pay laborers, workers, or mechanics employed in the performance of a public work contract not less than the prevailing rate of wage and supplements (fringe benefits) in the locality where the work is performed.

Responsibilities of the Department of Jurisdiction

A Department of Jurisdiction (Contracting Agency) includes a state department, agency, board or commission; a county, city, town or village; a school district, board of education or board of cooperative educational services; a sewer, water, fire, improvement and other district corporation; a public benefit corporation; and a public authority awarding a public work contract.

The Department of Jurisdiction (Contracting Agency) awarding a public work contract MUST obtain a Prevailing Rate Schedule listing the hourly rates of wages and supplements due the workers to be employed on a public work project. This schedule may be obtained by completing and forwarding a "Request for wage and Supplement Information" form (PW 39) to the Bureau of Public Work. The Prevailing Rate Schedule MUST be included in the specifications for the contract to be awarded and is deemed part of the public work contract.

Upon the awarding of the contract, the law requires that the Department of Jurisdiction (Contracting Agency) furnish the following information to the Bureau: the name and address of the contractor, the date the contract was let and the approximate dollar value of the contract. To facilitate compliance with this provision of the Labor Law, a copy of the Department's "Notice of Contract Award" form (PW 16) is provided with the original Prevailing Rate Schedule.

The Department of Jurisdiction (Contracting Agency) is required to notify the Bureau of the completion or cancellation of any public work project. The Department's PW 200 form is provided for that purpose.

Both the PW 16 and PW 200 forms are available for completion [online](#).

Hours

No laborer, worker, or mechanic in the employ of a contractor or subcontractor engaged in the performance of any public work project shall be permitted to work more than eight hours in any day or more than five days in any week, except in cases of extraordinary emergency. The contractor and the Department of Jurisdiction (Contracting Agency) may apply to the Bureau of Public Work for a dispensation permitting workers to work additional hours or days per week on a particular public work project.

Wages and Supplements

The wages and supplements to be paid and/or provided to laborers, workers, and mechanics employed on a public work project shall be not less than those listed in the current Prevailing Rate Schedule for the locality where the work is performed. If a prime contractor on a public work project has not been provided with a Prevailing Rate Schedule, the contractor must notify the Department of Jurisdiction (Contracting Agency) who in turn must request an original Prevailing Rate Schedule from the Bureau of Public Work. Requests may be submitted by: mail to NYSDOL, Bureau of Public Work, State Office Bldg. Campus, Bldg. 12, Rm. 130, Albany, NY 12226; Fax to Bureau of Public Work (518) 485-1870; or electronically at the NYSDOL website www.labor.ny.gov.

Upon receiving the original schedule, the Department of Jurisdiction (Contracting Agency) is REQUIRED to provide complete copies to all prime contractors who in turn MUST, by law, provide copies of all applicable county schedules to each subcontractor and obtain from each subcontractor, an affidavit certifying such schedules were received. If the original schedule expired, the contractor may obtain a copy of the new annual determination from the NYSDOL website www.labor.ny.gov.

The Commissioner of Labor makes an annual determination of the prevailing rates. This determination is in effect from July 1st through June 30th of the following year. The annual determination is available on the NYSDOL website www.labor.ny.gov.

Payrolls and Payroll Records

Every contractor and subcontractor MUST keep original payrolls or transcripts subscribed and affirmed as true under penalty of perjury. As per Article 6 of the Labor law, contractors and subcontractors are required to establish, maintain, and preserve for not less than six (6) years, contemporaneous, true, and accurate payroll records. At a minimum, payrolls must show the following information for each person employed on a public work project: Name, Address, Last 4 Digits of Social Security Number, Classification(s) in which the worker was employed, Hourly wage rate(s) paid, Supplements paid or provided, and Daily and weekly number of hours worked in each classification.

The filing of payrolls to the Department of Jurisdiction is a condition of payment. Every contractor and subcontractor shall submit to the Department of Jurisdiction (Contracting Agency), within thirty (30) days after issuance of its first payroll and every thirty (30) days thereafter, a transcript of the original payrolls, subscribed and affirmed as true under penalty of perjury. The Department of Jurisdiction (Contracting Agency) shall collect, review for facial validity, and maintain such payrolls.

In addition, the Commissioner of Labor may require contractors to furnish, with ten (10) days of a request, payroll records sworn to as their validity and accuracy for public work and private work. Payroll records include, but are not limited to time cards, work description sheets, proof that supplements were provided, cancelled payroll checks and payrolls. Failure to provide the requested information within the allotted ten (10) days will result in the withholding of up to 25% of the contract, not to exceed \$100,000.00. If the contractor or subcontractor does not maintain a place of business in New York State and the amount of the contract exceeds \$25,000.00, payroll records and certifications must be kept on the project worksite.

The prime contractor is responsible for any underpayments of prevailing wages or supplements by any subcontractor.

All contractors or their subcontractors shall provide to their subcontractors a copy of the Prevailing Rate Schedule specified in the public work contract as well as any subsequently issued schedules. A failure to provide these schedules by a contractor or subcontractor is a violation of Article 8, Section 220-a of the Labor Law.

All subcontractors engaged by a public work project contractor or its subcontractor, upon receipt of the original schedule and any subsequently issued schedules, shall provide to such contractor a verified statement attesting that the subcontractor has received the Prevailing Rate Schedule and will pay or provide the applicable rates of wages and supplements specified therein. (See NYS Labor Laws, Article 8 . Section 220-a).

Determination of Prevailing Wage and Supplement Rate Updates Applicable to All Counties

The wages and supplements contained in the annual determination become effective July 1st whether or not the new determination has been received by a given contractor. Care should be taken to review the rates for obvious errors. Any corrections should be brought to the Department's attention immediately. It is the responsibility of the public work contractor to use the proper rates. If there is a question on the proper classification to be used, please call the district office located nearest the project. Any errors in the annual determination will be corrected and posted to the NYSDOL website on the first business day of each month. Contractors are responsible for paying these updated rates as well, retroactive to July 1st.

When you review the schedule for a particular occupation, your attention should be directed to the dates above the column of rates. These are the dates for which a given set of rates is effective. To the extent possible, the Department posts rates in its possession that cover periods of time beyond the July 1st to June 30th time frame covered by a particular annual determination. Rates that extend beyond that instant time period are informational ONLY and may be updated in future annual determinations that actually cover the then appropriate July 1st to June 30th time period.

Withholding of Payments

When a complaint is filed with the Commissioner of Labor alleging the failure of a contractor or subcontractor to pay or provide the prevailing wages or supplements, or when the Commissioner of Labor believes that unpaid wages or supplements may be due, payments on the public work contract shall be withheld from the prime contractor in a sufficient amount to satisfy the alleged unpaid wages and supplements, including interest and civil penalty, pending a final determination.

When the Bureau of Public Work finds that a contractor or subcontractor on a public work project failed to pay or provide the requisite prevailing wages or supplements, the Bureau is authorized by Sections 220-b and 235.2 of the Labor Law to so notify the financial officer of the Department of Jurisdiction (Contracting Agency) that awarded the public work contract. Such officer MUST then withhold or cause to be withheld from any payment due the prime contractor on account of such contract the amount indicated by the Bureau as sufficient to satisfy the unpaid wages and supplements, including interest and any civil penalty that may be assessed by the Commissioner of Labor. The withholding continues until there is a final determination of the underpayment by the Commissioner of Labor or by the court in the event a legal proceeding is instituted for review of the determination of the Commissioner of Labor.

The Department of Jurisdiction (Contracting Agency) shall comply with this order of the Commissioner of Labor or of the court with respect to the release of the funds so withheld.

Summary of Notice Posting Requirements

The current Prevailing Rate Schedule must be posted in a prominent and accessible place on the site of the public work project. The prevailing wage schedule must be encased in, or constructed of, materials capable of withstanding adverse weather conditions and be titled "PREVAILING RATE OF WAGES" in letters no smaller than two (2) inches by two (2) inches.

The "[Public Work Project](#)" notice must be posted at the beginning of the performance of every public work contract, on each job site.

Every employer providing workers. compensation insurance and disability benefits must post notices of such coverage in the format prescribed by the Workers. Compensation Board in a conspicuous place on the jobsite.

Every employer subject to the NYS Human Rights Law must conspicuously post at its offices, places of employment, or employment training centers, notices furnished by the State Division of Human Rights.

Employers liable for contributions under the Unemployment Insurance Law must conspicuously post on the jobsite notices furnished by the NYS Department of Labor.

Apprentices

Employees cannot be paid apprentice rates unless they are individually registered in a program registered with the NYS Commissioner of Labor. The allowable ratio of apprentices to journeyworkers in any craft classification can be no greater than the statewide building trade ratios promulgated by the Department of Labor and included with the Prevailing Rate Schedule. An employee listed on a payroll as an apprentice who is not registered as above or is performing work outside the classification of work for which the apprentice is indentured, must be paid the prevailing journeyworker's wage rate for the classification of work the employee is actually performing.

NYSDOL Labor Law, Article 8, Section 220-3, require that only apprentices individually registered with the NYS Department of Labor may be paid apprenticeship rates on a public work project. No other Federal or State Agency of office registers apprentices in New York State.

Persons wishing to verify the apprentice registration of any person must do so in writing by mail, to the NYSDOL Office of Employability Development / Apprenticeship Training, State Office Bldg. Campus, Bldg. 12, Albany, NY 12226 or by Fax to NYSDOL Apprenticeship Training (518) 457-7154. All requests for verification must include the name and social security number of the person for whom the information is requested.

The only conclusive proof of individual apprentice registration is written verification from the NYSDOL Apprenticeship Training Albany Central office. Neither Federal nor State Apprenticeship Training offices outside of Albany can provide conclusive registration information.

It should be noted that the existence of a registered apprenticeship program is not conclusive proof that any person is registered in that program. Furthermore, the existence or possession of wallet cards, identification cards, or copies of state forms is not conclusive proof of the registration of any person as an apprentice.

Interest and Penalties

In the event that an underpayment of wages and/or supplements is found:

- Interest shall be assessed at the rate then in effect as prescribed by the Superintendent of Banks pursuant to section 14-a of the Banking Law, per annum from the date of underpayment to the date restitution is made.
- A Civil Penalty may also be assessed, not to exceed 25% of the total of wages, supplements, and interest due.

Debarment

Any contractor or subcontractor and/or its successor shall be ineligible to submit a bid on or be awarded any public work contract or subcontract with any state, municipal corporation or public body for a period of five (5) years when:

- Two (2) willful determinations have been rendered against that contractor or subcontractor and/or its successor within any consecutive six (6) year period.
- There is any willful determination that involves the falsification of payroll records or the kickback of wages or supplements.

Criminal Sanctions

Willful violations of the Prevailing Wage Law (Article 8 of the Labor Law) may be a felony punishable by fine or imprisonment of up to 15 years, or both.

Discrimination

No employee or applicant for employment may be discriminated against on account of age, race, creed, color, national origin, sex, disability or marital status.

No contractor, subcontractor nor any person acting on its behalf, shall by reason of race, creed, color, disability, sex or national origin discriminate against any citizen of the State of New York who is qualified and available to perform the work to which the employment relates (NYS Labor Law, Article 8, Section 220-e(a)).

No contractor, subcontractor, nor any person acting on its behalf, shall in any manner, discriminate against or intimidate any employee on account of race, creed, color, disability, sex, or national origin (NYS Labor Law, Article 8, Section 220-e(b)).

The Human Rights Law also prohibits discrimination in employment because of age, marital status, or religion.

There may be deducted from the amount payable to the contractor under the contract a penalty of \$50.00 for each calendar day during which such person was discriminated against or intimidated in violation of the provision of the contract (NYS Labor Law, Article 8, Section 220-e(c)).

The contract may be cancelled or terminated by the State or municipality. All monies due or to become due thereunder may be forfeited for a second or any subsequent violation of the terms or conditions of the anti-discrimination sections of the contract (NYS Labor Law, Article 8, Section 220-e(d)).

Every employer subject to the New York State Human Rights Law must conspicuously post at its offices, places of employment, or employment training centers notices furnished by the State Division of Human Rights.

Workers' Compensation

In accordance with Section 142 of the State Finance Law, the contractor shall maintain coverage during the life of the contract for the benefit of such employees as required by the provisions of the New York State Workers' Compensation Law.

A contractor who is awarded a public work contract must provide proof of workers' compensation coverage prior to being allowed to begin work.

The insurance policy must be issued by a company authorized to provide workers' compensation coverage in New York State. Proof of coverage must be on form C-105.2 (Certificate of Workers' Compensation Insurance) and must name this agency as a certificate holder.

If New York State coverage is added to an existing out-of-state policy, it can only be added to a policy from a company authorized to write workers' compensation coverage in this state. The coverage must be listed under item 3A of the information page.

The contractor must maintain proof that subcontractors doing work covered under this contract secured and maintained a workers' compensation policy for all employees working in New York State.

Every employer providing worker's compensation insurance and disability benefits must post notices of such coverage in the format prescribed by the Workers' Compensation Board in a conspicuous place on the jobsite.

Unemployment Insurance

Employers liable for contributions under the Unemployment Insurance Law must conspicuously post on the jobsite notices furnished by the New York State Department of Labor.



Kathy Hochul, Governor

Roberta Reardon, Commissioner

NYS Thruway Authority

Antonio Melendez, Professional Engineer 1
200 Southern Boulevard
Albany NY 12209

Schedule Year 2023 through 2024
Date Requested 12/27/2022
PRC# 2022013984

Location I-90, Interchange 40, MP 304.2
Project ID# D214913
Project Type Addition to the Maintenance Section Building & Roof Replacement at MP 304.2 in Cayuga County in accordance with the Plans and Specifications.

Notice of Contract Award

New York State Labor Law, Article 8, Section 220.3a requires that certain information regarding the awarding of public work contracts, be furnished to the Commissioner of Labor. One "Notice of Contract Award" (PW 16, which may be photocopied), **MUST** be completed for **EACH** prime contractor on the above referenced project.

Upon notifying the successful bidder(s) of this contract, enter the required information and mail **OR** fax this form to the office shown at the bottom of this notice, **OR** fill out the electronic version via the NYSDOL website.

Contractor Information

All information must be supplied

Federal Employer Identification Number: _____		
Name: _____		
Address: _____ _____		
City: _____	State: _____	Zip: _____
Amount of Contract: \$ _____	Contract Type:	
Approximate Starting Date: ____/____/____	<input type="checkbox"/> (01) General Construction	
Approximate Completion Date: ____/____/____	<input type="checkbox"/> (02) Heating/Ventilation	
	<input type="checkbox"/> (03) Electrical	
	<input type="checkbox"/> (04) Plumbing	
	<input type="checkbox"/> (05) Other : _____	

Phone: (518) 457-5589 Fax: (518) 485-1870
W. Averell Harriman State Office Campus, Bldg. 12, Room 130, Albany, NY 12226

Social Security Numbers on Certified Payrolls:

The Department of Labor is cognizant of the concerns of the potential for misuse or inadvertent disclosure of social security numbers. Identity theft is a growing problem and we are sympathetic to contractors' concern regarding inclusion of this information on payrolls if another identifier will suffice.

For these reasons, the substitution of the use of the last four digits of the social security number on certified payrolls submitted to contracting agencies on public work projects is now acceptable to the Department of Labor. This change does not affect the Department's ability to request and receive the entire social security number from employers during its public work/ prevailing wage investigations.

Construction Industry Fair Play Act: Required Posting for Labor Law Article 25-B § 861-d

Construction industry employers must post the "Construction Industry Fair Play Act" notice in a prominent and accessible place on the job site. Failure to post the notice can result in penalties of up to \$1,500 for a first offense and up to \$5,000 for a second offense. The posting is included as part of this wage schedule. Additional copies may be obtained from the NYS DOL website, <https://dol.ny.gov/public-work-and-prevailing-wage>

If you have any questions concerning the Fair Play Act, please call the State Labor Department toll-free at 1-866-435-1499 or email us at: dol.misclassified@labor.ny.gov .

Worker Notification: (Labor Law §220, paragraph a of subdivision 3-a)

Effective June 23, 2020

This provision is an addition to the existing wage rate law, Labor Law §220, paragraph a of subdivision 3-a. It requires contractors and subcontractors to provide written notice to all laborers, workers or mechanics of the *prevailing wage and supplement rate* for their particular job classification *on each pay stub**. It also requires contractors and subcontractors to *post a notice* at the beginning of the performance of every public work contract *on each job site* that includes the telephone number and address for the Department of Labor and a statement informing laborers, workers or mechanics of their right to contact the Department of Labor if he/she is not receiving the proper prevailing rate of wages and/or supplements for his/her job classification. The required notification will be provided with each wage schedule, may be downloaded from our website www.labor.ny.gov or be made available upon request by contacting the Bureau of Public Work at 518-457-5589. *In the event the required information will not fit on the pay stub, an accompanying sheet or attachment of the information will suffice.

(12.20)

**To all State Departments, Agency Heads and Public Benefit Corporations
IMPORTANT NOTICE REGARDING PUBLIC WORK ENFORCEMENT FUND**

Budget Policy & Reporting Manual

B-610

Public Work Enforcement Fund

effective date December 7, 2005

1. Purpose and Scope:

This Item describes the Public Work Enforcement Fund (the Fund, PWEF) and its relevance to State agencies and public benefit corporations engaged in construction or reconstruction contracts, maintenance and repair, and announces the recently-enacted increase to the percentage of the dollar value of such contracts that must be deposited into the Fund. This item also describes the roles of the following entities with respect to the Fund:

- New York State Department of Labor (DOL),
- The Office of the State of Comptroller (OSC), and
- State agencies and public benefit corporations.

2. Background and Statutory References:

DOL uses the Fund to enforce the State's Labor Law as it relates to contracts for construction or reconstruction, maintenance and repair, as defined in subdivision two of Section 220 of the Labor Law. State agencies and public benefit corporations participating in such contracts are required to make payments to the Fund.

Chapter 511 of the Laws of 1995 (as amended by Chapter 513 of the Laws of 1997, Chapter 655 of the Laws of 1999, Chapter 376 of the Laws of 2003 and Chapter 407 of the Laws of 2005) established the Fund.

3. Procedures and Agency Responsibilities:

The Fund is supported by transfers and deposits based on the value of contracts for construction and reconstruction, maintenance and repair, as defined in subdivision two of Section 220 of the Labor Law, into which all State agencies and public benefit corporations enter.

Chapter 407 of the Laws of 2005 increased the amount required to be provided to this fund to .10 of one-percent of the total cost of each such contract, to be calculated at the time agencies or public benefit corporations enter into a new contract or if a contract is amended. The provisions of this bill became effective August 2, 2005.

**To all State Departments, Agency Heads and Public Benefit Corporations
IMPORTANT NOTICE REGARDING PUBLIC WORK ENFORCEMENT FUND**

OSC will report to DOL on all construction-related ("D") contracts approved during the month, including contract amendments, and then DOL will bill agencies the appropriate assessment monthly. An agency may then make a determination if any of the billed contracts are exempt and so note on the bill submitted back to DOL. For any instance where an agency is unsure if a contract is or is not exempt, they can call the Bureau of Public Work at the number noted below for a determination. Payment by check or journal voucher is due to DOL within thirty days from the date of the billing. DOL will verify the amounts and forward them to OSC for processing.

For those contracts which are not approved or administered by the Comptroller, monthly reports and payments for deposit into the Public Work Enforcement Fund must be provided to the Administrative Finance Bureau at the DOL within 30 days of the end of each month or on a payment schedule mutually agreed upon with DOL.

Reports should contain the following information:

- Name and billing address of State agency or public benefit corporation;
- State agency or public benefit corporation contact and phone number;
- Name and address of contractor receiving the award;
- Contract number and effective dates;
- Contract amount and PWEF assessment charge (if contract amount has been amended, reflect increase or decrease to original contract and the adjustment in the PWEF charge); and
- Brief description of the work to be performed under each contract.

Checks and Journal Vouchers, payable to the "New York State Department of Labor" should be sent to:

Department of Labor
Administrative Finance Bureau-PWEF Unit
Building 12, Room 464
State Office Campus
Albany, NY 12226

Any questions regarding billing should be directed to NYSDOL's Administrative Finance Bureau-PWEF Unit at (518) 457-3624 and any questions regarding Public Work Contracts should be directed to the Bureau of Public Work at (518) 457-5589.

Required Notice under Article 25-B of the Labor Law

Attention All Employees, Contractors and Subcontractors: You are Covered by the Construction Industry Fair Play Act

The law says that you are an employee unless:

- You are free from direction and control in performing your job, **and**
- You perform work that is not part of the usual work done by the business that hired you, **and**
- You have an independently established business.

Your employer cannot consider you to be an independent contractor unless all three of these facts apply to your work.

It is against the law for an employer to misclassify employees as independent contractors or pay employees off the books.

Employee Rights: If you are an employee, you are entitled to state and federal worker protections. These include:

- Unemployment Insurance benefits, if you are unemployed through no fault of your own, able to work, and otherwise qualified,
- Workers' compensation benefits for on-the-job injuries,
- Payment for wages earned, minimum wage, and overtime (under certain conditions),
- Prevailing wages on public work projects,
- The provisions of the National Labor Relations Act, and
- A safe work environment.

It is a violation of this law for employers to retaliate against anyone who asserts their rights under the law. Retaliation subjects an employer to civil penalties, a private lawsuit or both.

Independent Contractors: If you are an independent contractor, **you must pay all taxes and Unemployment Insurance contributions required by New York State and Federal Law.**

Penalties for paying workers off the books or improperly treating employees as independent contractors:

- **Civil Penalty** First offense: Up to \$2,500 per employee
 Subsequent offense(s): Up to \$5,000 per employee
- **Criminal Penalty** First offense: Misdemeanor - up to 30 days in jail, up to a \$25,000 fine and debarment from performing public work for up to one year.
 Subsequent offense(s): Misdemeanor - up to 60 days in jail or up to a \$50,000 fine and debarment from performing public work for up to 5 years.

If you have questions about your employment status or believe that your employer may have violated your rights and you want to file a complaint, call the Department of Labor at (866) 435-1499 or send an email to dol.misclassified@labor.ny.gov. All complaints of fraud and violations are taken seriously. You can remain anonymous.

Employer Name:

IA 999 (09/16)

WE ARE YOUR DOLDepartment
of LaborNew York State Department of Labor
Bureau of Public Work

Attention Employees

THIS IS A: **PUBLIC WORK PROJECT**

If you are employed on this project as a **worker, laborer, or mechanic** you are entitled to receive the **prevailing wage and supplements rate** for the classification at which you are working.

Your pay stub and wage notice received upon hire must clearly state your wage rate and supplement rate.

Chapter 629 of the Labor Laws of 2007:

These wages are set by law and must be posted at the work site. They can also be found at:
<https://dol.ny.gov/bureau-public-work>



If you feel that you have not received proper wages or benefits, please call our nearest office.*

Albany	(518) 457-2744	Patchogue	(631) 687-4882
Binghamton	(607) 721-8005	Rochester	(585) 258-4505
Buffalo	(716) 847-7159	Syracuse	(315) 428-4056
Garden City	(516) 228-3915	Utica	(315) 793-2314
New York City	(212) 932-2419	White Plains	(914) 997-9507
Newburgh	(845) 568-5287		

* For New York City government agency construction projects, please contact the Office of the NYC Comptroller at (212) 669-4443, or www.comptroller.nyc.gov – click on Bureau of Labor Law.

Contractor Name: _____

Project Location: _____

Requirements for OSHA 10 Compliance

Article 8 §220-h requires that when the advertised specifications, for every contract for public work, is \$250,000.00 or more the contract must contain a provision requiring that every worker employed in the performance of a public work contract shall be certified as having completed an OSHA 10 safety training course. The clear intent of this provision is to require that all employees of public work contractors, required to be paid prevailing rates, receive such training "prior to the performing any work on the project."

The Bureau will enforce the statute as follows:

All contractors and sub contractors must attach a copy of proof of completion of the OSHA 10 course to the first certified payroll submitted to the contracting agency and on each succeeding payroll where any new or additional employee is first listed.

Proof of completion may include but is not limited to:

- Copies of bona fide course completion card (*Note: Completion cards do not have an expiration date.*)
- Training roster, attendance record or other documentation from the certified trainer pending the issuance of the card.
- Other valid proof

**A certification by the employer attesting that all employees have completed such a course is not sufficient proof that the course has been completed.

Any questions regarding this statute may be directed to the New York State Department of Labor, Bureau of Public Work at 518-457-5589.

(07.19)

Introduction to the Prevailing Rate Schedule

Information About Prevailing Rate Schedule

This information is provided to assist you in the interpretation of particular requirements for each classification of worker contained in the attached Schedule of Prevailing Rates.

Classification

It is the duty of the Commissioner of Labor to make the proper classification of workers taking into account whether the work is heavy and highway, building, sewer and water, tunnel work, or residential, and to make a determination of wages and supplements to be paid or provided. It is the responsibility of the public work contractor to use the proper rate. If there is a question on the proper classification to be used, please call the district office located nearest the project. District office locations and phone numbers are listed below.

Prevailing Wage Schedules are issued separately for "General Construction Projects" and "Residential Construction Projects" on a county-by-county basis.

General Construction Rates apply to projects such as: Buildings, Heavy & Highway, and Tunnel and Water & Sewer rates.

Residential Construction Rates generally apply to construction, reconstruction, repair, alteration, or demolition of one family, two family, row housing, or rental type units intended for residential use.

Some rates listed in the Residential Construction Rate Schedule have a very limited applicability listed along with the rate. Rates for occupations or locations not shown on the residential schedule must be obtained from the General Construction Rate Schedule. Please contact the local Bureau of Public Work office before using Residential Rate Schedules, to ensure that the project meets the required criteria.

Payrolls and Payroll Records

Contractors and subcontractors are required to establish, maintain, and preserve for not less than six (6) years, contemporaneous, true, and accurate payroll records.

Every contractor and subcontractor shall submit to the Department of Jurisdiction (Contracting Agency), within thirty (30) days after issuance of its first payroll and every thirty (30) days thereafter, a transcript of the original payrolls, subscribed and affirmed as true under penalty of perjury.

Paid Holidays

Paid Holidays are days for which an eligible employee receives a regular day's pay, but is not required to perform work. If an employee works on a day listed as a paid holiday, this remuneration is in addition to payment of the required prevailing rate for the work actually performed.

Overtime

At a minimum, all work performed on a public work project in excess of eight hours in any one day or more than five days in any workweek is overtime. However, the specific overtime requirements for each trade or occupation on a public work project may differ. Specific overtime requirements for each trade or occupation are contained in the prevailing rate schedules.

Overtime holiday pay is the premium pay that is required for work performed on specified holidays. It is only required where the employee actually performs work on such holidays.

The applicable holidays are listed under HOLIDAYS: OVERTIME. The required rate of pay for these covered holidays can be found in the OVERTIME PAY section listings for each classification.

Supplemental Benefits

Particular attention should be given to the supplemental benefit requirements. Although in most cases the payment or provision of supplements is straight time for all hours worked, some classifications require the payment or provision of supplements, or a portion of the supplements, to be paid or provided at a premium rate for premium hours worked. Supplements may also be required to be paid or provided on paid holidays, regardless of whether the day is worked. The Overtime Codes and Notes listed on the particular wage classification will indicate these conditions as required.

Effective Dates

When you review the schedule for a particular occupation, your attention should be directed to the dates above the column of rates. These are the dates for which a given set of rates is effective. The rate listed is valid until the next effective rate change or until the new annual determination which takes effect on July 1 of each year. All contractors and subcontractors are required to pay the current prevailing rates of wages and supplements. If you have any questions please contact the Bureau of Public Work or visit the New York State Department of Labor website (www.labor.ny.gov) for current wage rate information.

Apprentice Training Ratios

The following are the allowable ratios of registered Apprentices to Journey-workers.

For example, the ratio 1:1,1:3 indicates the allowable initial ratio is one Apprentice to one Journeyworker. The Journeyworker must be in place on the project before an Apprentice is allowed. Then three additional Journeyworkers are needed before a second Apprentice is allowed. The last ratio repeats indefinitely. Therefore, three more Journeyworkers must be present before a third Apprentice can be hired, and so on.

Please call Apprentice Training Central Office at (518) 457-6820 if you have any questions.

Title (Trade)	Ratio
Boilermaker (Construction)	1:1,1:4
Boilermaker (Shop)	1:1,1:3
Carpenter (Bldg.,H&H, Pile Driver/Dockbuilder)	1:1,1:4
Carpenter (Residential)	1:1,1:3
Electrical (Outside) Lineman	1:1,1:2
Electrician (Inside)	1:1,1:3
Elevator/Escalator Construction & Modernizer	1:1,1:2
Glazier	1:1,1:3
Insulation & Asbestos Worker	1:1,1:3
Iron Worker	1:1,1:4
Laborer	1:1,1:3
Mason	1:1,1:4
Millwright	1:1,1:4
Op Engineer	1:1,1:5
Painter	1:1,1:3
Plumber & Steamfitter	1:1,1:3
Roofer	1:1,1:2
Sheet Metal Worker	1:1,1:3
Sprinkler Fitter	1:1,1:2

If you have any questions concerning the attached schedule or would like additional information, please contact the nearest BUREAU of PUBLIC WORK District Office or write to:

New York State Department of Labor
Bureau of Public Work
State Office Campus, Bldg. 12
Albany, NY 12226

District Office Locations:	Telephone #	FAX #
Bureau of Public Work - Albany	518-457-2744	518-485-0240
Bureau of Public Work - Binghamton	607-721-8005	607-721-8004
Bureau of Public Work - Buffalo	716-847-7159	716-847-7650
Bureau of Public Work - Garden City	516-228-3915	516-794-3518
Bureau of Public Work - Newburgh	845-568-5287	845-568-5332
Bureau of Public Work - New York City	212-932-2419	212-775-3579
Bureau of Public Work - Patchogue	631-687-4882	631-687-4902
Bureau of Public Work - Rochester	585-258-4505	585-258-4708
Bureau of Public Work - Syracuse	315-428-4056	315-428-4671
Bureau of Public Work - Utica	315-793-2314	315-793-2514
Bureau of Public Work - White Plains	914-997-9507	914-997-9523
Bureau of Public Work - Central Office	518-457-5589	518-485-1870

**AGREEMENT,
FAITHFUL
PERFORMANCE
BOND,
AND
LABOR AND
MATERIAL
BOND**

745

CONTRACT NO:

COUNTY:

**NEW YORK STATE
THRUWAY AUTHORITY**

A G R E E M E N T

NEW YORK STATE THRUWAY AUTHORITY

AGREEMENT

CONTRACT NO:

This **AGREEMENT**, entered into this day of _____, by the **NEW YORK STATE THRUWAY AUTHORITY** (hereinafter referred to as the "**AUTHORITY**") having its principal office at 200 Southern Blvd. (P. O. Box 189, Albany, NY 12201) in the County of Albany and State of New York and hereinafter called the "**CONTRACTOR**",

- a corporation organized and existing under the laws of the State of _____
- a partnership, consisting of _____
- an individual conducting business as _____

the location of whose principal office is _____

WITNESSETH: That the Authority and the Contractor for the consideration hereinafter named agree as follows:

ARTICLE 1. WORK TO BE DONE.

The Contractor shall (a) furnish all the materials, appliances, tools and labor of every kind required, and construct and complete in the most substantial and skillful manner, the construction, improvement or reconstruction of the project on or before the completion date of the as further described in ARTICLE 4, and as generally identified and shown on the plans entitled:

in accordance with the "Standard Specifications" of the New York State Department of Transportation, which contain the information for bidders; form of proposal, agreement, and bonds; general specifications and conditions or contract; materials of construction; and payment items; and (b) do everything required by the Contract (Contract Documents) as defined herein.

The Contractor agrees that its proposal contained herein is based upon performing all the work of the Contract in accordance with a schedule that will result in the completion of the total works by the Date of Completion of the Contract and all intermediate stage and phase completion requirements of the contract, while adhering to all restrictions set forth in the Schedule and Suspension of Work, the Thruway Traffic Plan, and the General and Special Notes, and that the work will be performed at the unit bid prices, as shown on the contract documents and as detailed in the specifications and notes, utilizing the Labor Force, Qualified Disadvantaged, Women Owned and Minority Owned Subcontractor Entrepreneurs and Methods and Materials of Construction as described in the Contract Documents and any incorporated Addenda thereto, and conduct its operations in accordance with the Vehicle and Traffic Law, the Rules and Regulations of the NYS Thruway Authority, and the Thruway Operating Rules and General and Special Notes that are part of this proposal. The Contractor further agrees its proposal is not based upon the assumption that any specifications, traffic restrictions, scheduling or phasing/staging requirements will be waived, an extension of Contract Completion Date will be granted, a labor dispensation will be granted, substitution of non-approved products, alternatives or claimed functional equivalents for Specified Construction Materials and Methods will be allowed, or any Value Engineering Proposals will be entertained and approved by the New York State Thruway Authority, and any requests for a substitution, equivalent or alternate, which it proposes, will be accompanied by an agreed price analysis establishing an applicable credit or illustrating cost equal to or greater than the bid amount.

ARTICLE 2. DOCUMENTS FORMING THE CONTRACT.

The Contract (and Contract Documents) shall be deemed to include the advertisement for proposals; the contractor's proposal; the Schedule for Participation By Disadvantaged Business Enterprise Participation goals; the agreement; the "Standard Specifications" including all addenda thereto referred to above; the plans; any addenda and/or amendments to specifications if the same are issued prior to date of receipt of proposal and all provisions required by law to be inserted in the contract whether actually inserted or not. Appendix A, standard clauses for all N.Y State contracts, is attached hereto and is hereby made a part of this agreement as if set forth fully herein.

ARTICLE 3. EXAMINATION OF DOCUMENTS AND SITE.

The Contractor agrees that before making its proposal it carefully examined the contract documents, together with the site of the proposed work, as well as its surrounding territory, and is informed regarding all of the conditions affecting the work to be done and labor and materials to be furnished for the completion of this contract, including the existence of poles, wires, pipes, and other facilities and structures of municipal and other public service corporations on, over or under the site, except latent conditions that meet the requirements of §104-04 and §109-05, and that its information was secured by personal investigation and research.

ARTICLE 4. DATE OF COMPLETION.

The Contractor further agrees that it will begin the work herein embraced within ten days of the effective date hereof, unless the consent of the Authority, in writing, is given to begin at a later date, and that it will prosecute the same so that it shall be entirely completed and performed on or before the completion date shown in Article 1.

No extension beyond the date of completion fixed by the terms of this contract shall be effective unless in writing signed by the Authority. Such extension shall be for such time and upon such terms and conditions as shall be fixed by the Authority, which may include the assessment of liquidated damages and a charge for engineering and inspection expenses actually incurred upon the work, including engineering and inspection expenses incurred upon the work by railroad companies on contracts for grade crossing elimination. Notice of application for such extension shall be filed with the Chief Engineer, Department of Engineering of the Authority at least fifteen days prior to the date of completion fixed by the terms of this agreement.

ARTICLE 5. ALTERATIONS AND OMISSIONS.

The said work shall be performed in accordance with the true intent and meaning of the contract documents without any further expense of any nature whatsoever to the Authority other than the consideration named in this agreement.

The Authority reserves the right at any time during the progress of the work, to alter the plans or omit any portion of the work as it may deem reasonably necessary for the public interest; making allowances for additions and deductions with compensation made in accordance with the Standard Specifications, for this work without constituting grounds for any claim by the contractor for allowance for damages or for loss of anticipated profits, or for any variations between the approximate quantities and the quantities of the work as done.

ARTICLE 6. NO COLLUSION OR FRAUD.

The Contractor hereby agrees that the only person or persons interested as principal or principals in the bid or proposal submitted by the Contractor for this contract are named therein, and that no person other than those mentioned therein has any interest in the above-mentioned proposal or in securing of the award, and that this contract has been secured without any connection with any person or persons other than those named, and that the proposal is in all respects fair and was prepared and the contract was secured without collusion or fraud and that neither any officer nor employee of the New York State Thruway Authority or the State Department of Transportation or either of them has or shall have a financial interest in the performance of the contract or in the supplies, work or business to which it relates, or in any portion of the profits thereof. (See also Section 139-a and 139-b of the State Finance Law referred to in the Standard Specifications, which are made a part of this contract.)

ARTICLE 7. CONTRACT PAYMENTS.

As the work progresses in accordance with the contract and in a manner that is satisfactory to the Authority, the Authority hereby agrees to make payments to the Contractor therefore, based upon the proposal attached hereto and made a part hereof, as follows: The Authority shall, once in each month and on such days as it may fix, make an estimate of the quantity of work done and of material which has actually been put in place in accordance with the terms and conditions of the contract, during the preceding month, and compute the value thereof and pay to the Contractor the moneys due in accordance with Public Authorities Law Section 2880, as detailed in 21 NYCRR Part 109 (Prompt Payment). No monthly estimate shall be rendered unless the Contractor has provided acceptable documentation with regard to actions taken to comply with the M/WBE goals of the contract (see also §109-06 Contract Payments) and the value of the work done equals 5% of the contract amount or \$1,000, whichever is the lesser. Semi-monthly estimates may be rendered provided (a) the value of the work performed in two successive weeks is more than \$100,000 or (b) the Chairman of

the Authority deems it to be for the best interest of the Authority to do so.

Contractor understands and agrees that payments will only be rendered electronically unless payment by paper check is expressly authorized by the Authority, in its sole discretion, due to extenuating circumstances. Contractor shall comply with the Authority's procedures to authorize electronic payments. Authorization forms are available at <http://www.thruway.ny.gov/business/purchasing/epayments/index.html>, by e-mail at suppliermgmt@thruway.ny.gov, or by telephone at (518) 436-2859. Contractor acknowledges that it will not receive payment of any estimates submitted under this Agreement if it does not comply with the Authority's electronic payment procedures, except where the Authority has expressly authorized payment by paper check as set forth above.

ARTICLE 8. PAYMENT DUE TO CONTRACTOR'S NON-COMPLIANCE.

It is further agreed that so long as any lawful or proper direction concerning the work or material given by the Chief Engineer, Department of Engineering of the New York State Thruway Authority, or his/her representative, shall remain uncomplied with, the Contractor shall not be entitled to have any estimate made for the purpose of payment, nor shall any estimate be rendered on account of work done or material furnished until such lawful or proper direction aforesaid has been fully and satisfactorily complied with.

ARTICLE 9. FINAL ACCEPTANCE OF WORK.

When in the opinion of the Thruway Division Director, a Contractor has fully performed the work under the contract, the Thruway Division Director shall recommend to the Chief Engineer, Department of Engineering of the New York State Thruway Authority, the acceptance of the work so completed. If the Chief Engineer, Department of Engineering accepts the recommendation of the Thruway Division Director, he/she shall thereupon by letter notify the Contractor of such acceptance. Copies of such acceptance shall be sent to other interested parties. Prior to the final acceptance of the work by the Chief Engineer, Department of Engineering of the New York State Thruway Authority or a designee, the contract work may be inspected, accepted and approved by other agencies and/or municipalities who will have jurisdiction of the work after final acceptance.

Final acceptance shall be final and conclusive except for defects not readily ascertainable by the New York State Thruway Authority, actual or constructive, fraud, gross mistakes amounting to fraud or other errors which the Contractor knew or should have known about as well as the New York State Thruway Authority's rights under any warranty or guarantee. Final acceptance may be revoked by the New York State Thruway Authority at any time prior to the issuance of the final check, upon the New York State Thruway Authority's discovery of such defects, mistakes, fraud or errors in the work.

ARTICLE 10. FINAL PAYMENT.

After the final acceptance of the work, the Engineer shall prepare a final agreement of the work performed and the materials placed and shall compute the value of such work and materials under and according to the terms of the contract.

This agreement shall be certified, as to its correctness, by the Engineer. Upon approval of such final agreement by the Director, Office of Construction Management, it shall be submitted to the Chief Engineer,

Department of Engineering for final approval. The right, however, is hereby reserved to the Chief Engineer, Department of Engineering to reject the whole or any portion of the final agreement, should the said certificate of the Engineer be found or known to be inconsistent with the terms of the agreement or otherwise improperly given. All certificates, upon which partial payments may have been made being merely estimates, shall be subject to correction in the final certificate or final agreement.

ARTICLE 11. RIGHT TO SUSPEND WORK AND CANCEL CONTRACT.

Article 11.1 General Right to Suspend and Cancel Contract.

It is further mutually agreed that if at any time during the prosecution of the work the Authority shall determine that the work is not being performed in accordance with the Contract or for the best interest of the Authority, the Chief Engineer, Department of Engineering, may proceed in any of the following ways:

- 1) Temporarily suspend the execution of the work by the Contractor, and the Chief Engineer of the Authority may then proceed with the work under his/her own direction in such manner as will accord with the Contract Documents and be for the best interests of the Authority; or
- 2) Terminate the Contract while it is in progress, and thereupon proceed with the work by a new contract negotiated or publicly advertised, by the use of his/her own forces, by calling upon the Surety to complete the Work in accordance with the Contract Documents, or by a combination of any such methods; or
- 3) Cancel the Contract and re-advertise and re-procure in accordance with applicable law; or
- 4) Complete the Work under the Authority's direction in such a manner as will accord with the Contract Documents and be for the best interests of the Authority.

Any excess in the cost of completing the Contract beyond the Contract Price for which it was originally awarded shall be charged to and paid by the Contractor failing to perform the Work or its Surety, all pursuant to the provisions of Section 40 of the New York State Highway Law.

In the event of suspension or termination, the Contractor shall be paid its costs, including contract close-out costs, and profit on work satisfactorily performed and project design costs actually incurred up to the time of termination, less an amount necessary to satisfy any claims, liens or judgments against the Contractor. The Contractor shall promptly submit its termination claim. The Contractor will only be paid the contract price for materials delivered and accepted, or services performed in accordance with the manner or performance set forth in this contract, less an amount necessary to satisfy any claims, liens or judgments against the Contractor.

Whenever the Authority determines to suspend or stop Work under this Contract, a written notice sent by mail to the Contractor at its address and to its Sureties at their respective addresses shall be sufficient notice of its action in the premises.

Article 11.2 Termination for Cause.

- A. If at any time during the prosecution of the work the Chief Engineer shall determine that the work under the Contract is not being performed according to the Contract or any

provision of the Contract is violated by the Contractor or by any subcontractor or that an Event of Default (as defined below) has occurred hereunder, the Chief Engineer, in his or her sole and absolute discretion, may proceed in any of the following ways:

- (1) Suspend or stop work by the Contractor, and the Chief Engineer may then complete the Work under his/her own direction in such manner as further described in the Contract Documents and as determined by the Chief Engineer to be in the best interests of the Authority; or
- (2) Terminate the Contract while it is in progress, and thereupon complete the work by: a new contract negotiated or publicly advertised; use of the Authority's own forces; calling upon the Surety to complete the Work in accordance with the Contract; or a combination of any such methods; or
- (3) Terminate the Contract and re-advertise as provided in law or if applicable, demand upon the Surety to complete any and all remaining work pursuant to the terms of the Contract and the Faithful Performance Bond.

As used herein, an "Event of Default" shall mean a material breach of the Contract by the Contractor which, without limitation, the following has occurred: (i) the Contractor has failed to begin the work in accordance with the Contract requirements; (ii) performance of this Contract has been unnecessarily or unreasonably delayed, (iii) the Contractor has willfully violated any of the provisions of the Contract or has not executed the same in good faith and in accordance with this Contract; (iv) the Contractor has abandoned the work; (v) the Contractor has become insolvent (other than as a bankrupt), or has assigned the proceeds of this Contract for the benefit of creditors, or taken advantage of any insolvency statute or debtor or creditor law or if his property or affairs have been put in the hands of a receiver; (vi) the Contractor has failed to obtain an approval required by the Contract; (vii) the Contractor has failed to provide the required insurances; (viii) the Contractor has failed to provide "adequate assurance" as required; or (ix) the Contractor is found to be non-responsible.

- B. Any excess in the cost of completing the Contract beyond the price for which it was originally awarded shall be charged to and paid by the Contractor failing to perform the work or by the Contractor's Surety, pursuant to the terms and conditions of Section 40 of the New York State Highway Law and the Faithful Performance Bond.
- C. Whenever the Authority determines to suspend, stop work, or terminate under this provision of the Contract, the Contractor and Surety shall receive written notice specifying the basis for such default (the "Default Notice"). Contractor shall have fifteen (15) days from the date of the Default Notice to cure such default, except that, at Authority's sole discretion, the Authority may extend such fifteen (15) day period for such additional period as the Authority shall deem appropriate without waiver of any of its rights hereunder. The Default Notice shall specify the date the Contractor is to discontinue all work if such default is not timely cured (the "Termination Date"). If the Event of Default is not cured or arrangements satisfactory to the Authority are not made (as evidenced in writing by the Authority) within the designated cure period, then Contractor shall suspend work and/or the Contract shall terminate, as the case may be, upon the Termination Date.

- D. Upon occurrence of an Event of Default or a termination for cause pursuant to this Article, the Authority has the remedies set forth in the Faithful Performance Bond, the Contract, and all remedies at law or in equity.
- E. In the event the termination for cause is determined to be improper, the termination shall be deemed a Termination for Convenience as identified in Article 11.3.

Article 11.3 Termination for Convenience.

- A. The Authority, at any time, may terminate the Contract in whole or in part. Any such termination shall be effected by delivering to the Contractor a written notice of termination specifying the extent to which performance of work under the Contract is terminated and the date upon which the termination becomes effective. Upon receipt of the notice of termination, the Contractor shall act promptly to minimize the expenses resulting from the termination.
- B. The Authority shall pay the Contractor for work of the contract performed by the Contractor and accepted by the Authority for the period extending from the end of the period covered by the last approved Application for Payment up to the effective date of the termination, an amount determined in accordance with the Contract Documents. In no event shall the Contractor be entitled to compensation in excess of the total consideration of the Contract. In no event shall the Contractor be entitled to overhead or profit on the work not performed.
- C. In the event of such termination, the Authority may take over the work and prosecute the Contract to completion and may take possession of and may utilize such materials, appliances, and equipment on the site and necessary or useful in completing the work. The Authority also has the right to suspend the execution of the Work for convenience and/or to terminate the Contract for convenience.

Whenever the New York State Thruway Authority determines to suspend or stop work under the contract, a written notice sent by mail to the Contractor at its address and to the sureties at their respective addresses, shall be sufficient notice of its action in the premises.

Article 11.4 Termination for Vendor Responsibility.

- A. Contractor shall at all times during the Contract term remain responsible. Contractor agrees, if requested by the Authority, to present evidence of its continuing legal authority to do business in New York State, integrity, experience, ability, prior performance, and organizational and financial capacity.
- B. The Authority, in its sole discretion, reserves the right to suspend any or all activities under this Contract, at any time, when it discovers information that calls in to question the responsibility of Contractor. In the event of such suspension, Contractor will be given written notice outlining the particulars of such suspension. Upon issuance of such notice, Contractor shall comply with the terms of the suspension order. Contract activity may resume at such time as the Authority issues a written notice authorizing a resumption of performance under the Contract.
- C. Notwithstanding any other provision of this Contract, if the Authority determines Contractor to be non-responsible, the Authority shall have the right to terminate the Contract for cause pursuant to the terms of Article 11.2 - Termination for Cause herein.

In such event, the Authority shall have all rights and remedies set forth in Article 11.2, including, without limitation, the right to complete Contractor's contractual requirements in any manner the Authority may deem advisable and to pursue available legal or equitable remedies for the breach.

- D. In no event shall termination of the Contract by the Authority for reasons of Contractor's non-responsibility be deemed a breach by the Authority, nor shall the Authority be liable for any damages or lost profits or otherwise that Contractor may incur as a result of such termination.
- E. The Authority may require at any time the removal of a subcontractor to the Contractor that the Authority determines is not responsible.

ARTICLE 12. DETERMINATION AS TO VARIANCES.

In any case of any ambiguity in the plans, specifications or maps, or between any of them, the matter must be immediately submitted to the Chief Engineer, Department of Engineering, who shall adjust the same, and his/her decision in relation thereto shall be final and conclusive upon the parties.

ARTICLE 13. SUCCESSORS AND ASSIGNS.

This Agreement shall bind the successors, assigns and representatives of the parties hereto.

ARTICLE 14. INTERNATIONAL BOYCOTT PROHIBITION.

In accordance with Chapter 406 of the Laws of 1981, the Contractor hereby promises, asserts and represents that neither the Contractor nor any substantially owned or affiliated person, firm, partnership or corporation has participated, is participating or shall participate in an international boycott in violation of the provisions of the United States Export Administration Act of 1969, as amended, or the United States Export Administration Act of 1979, or the effective Regulations of the United States Department of Commerce promulgated under either act.

It is understood further that the Authority in awarding a contract does so in material reliance upon the promise and representation made by the Contractor in the foregoing paragraph and that such contract shall be rendered forfeit and void by the State Comptroller if subsequent to the bid execution date, the Contractor or such owned or affiliated person, firm, partnership or corporation has been convicted of a violation of the aforesaid Acts or Regulations or has been found upon final determination of the United States Commerce Department or any other appropriate agency of the United States to have violated such Acts or Regulations.

The Contractor agrees to and shall notify the Chief Engineer, Department of Engineering and the Director of the Office of Construction Management and the Director of State Expenditures in the Office of the State Comptroller of any such conviction or final determination of violation within five (5) days thereof.

ARTICLE 15. CERTIFICATION OF STATE FINANCE LAW SECTIONS 139-J AND 139-K.

By execution of this Agreement the Contractor certifies that all information provided with respect to New York State Finance Law Section 139-j and Section 139-k is complete, true and accurate. The Authority shall have a right to terminate this Agreement in the event the Authority finds that the certification made by the Contractor in accordance with New York State Finance Law Sections 139-j and 139-k was intentionally false or intentionally incomplete. This

includes the Authority's right to terminate this Agreement at any time in the event the Authority finds that Contractor is non-responsible or has failed to accurately disclose vendor responsibility information.

ARTICLE 16. WRITTEN NOTICES.

All notices permitted or required hereunder shall be in writing and transmitted by either:

- a. certified or registered United States mail, return receipt requested;
- b. facsimile transmission;
- c. personal delivery;
- d. expedited delivery service; or
- e. e-mail.

Such notices shall be addressed to the individuals or titles named in the contract documents, or which are designated by the Contractor or the Authority at the pre-construction meeting, or which are designated by the Authority or the Contractor from time to time during the course of the Contract pursuant to the requirements herein.

Any such notice shall be deemed to have been given either at the time of personal delivery or, in the case of expedited delivery service or certified or registered United States mail, as of the date of first attempted delivery at the address and in the manner provided herein, or in the case of facsimile transmission or email, upon receipt.

The parties may, from time to time, specify a new or different address in the United States as their address for the purpose of receiving notice under this Agreement by giving fifteen (15) days written notice to the other party sent in accordance herewith. The parties agree to mutually designate individuals as their respective representatives for the purposes of receiving notices under this Agreement. Additional individuals may be designated in writing by the parties for purposes of implementation and administration/billing, resolving issues and problems and/or for dispute resolution.

ARTICLE 17. SUBCONTRACTING.

Contractor agrees not to subcontract any of its services without the prior written approval of the Authority.

Contractor retains ultimate responsibility for all services performed under the Agreement and shall pay any subcontractors promptly for work performed under this Agreement. Contractor shall be fully responsible to the Authority for the acts and omissions of its subcontractors, and of persons either directly or indirectly employed by them, just as Contractor is fully responsible to the Authority for the acts and omissions of persons directly employed by Contractor.

All subcontracts shall be in writing and shall contain provisions, which are functionally identical to, and consistent with, the provisions of this Agreement including, but not limited to, the body of this Agreement, Appendix A – Standard Clauses for New York State Thruway Authority Contracts, and the Contract Documents. Unless expressly waived in writing by the Authority, all subcontracts between the Contractor and its subcontractors shall expressly name the Authority, as the sole intended third party beneficiary of such subcontract. The Authority reserves the right to review and approve or reject any subcontract, as well as any amendment to said subcontract(s), and this right shall not make the Authority a party to any subcontract or create any right, claim, or interest in the subcontractor or proposed

subcontractor against the Authority. The Authority shall have the right to withdraw its consent to a subcontractor if, at the sole discretion of the Authority, it appears that the subcontract will delay, prevent, or otherwise impair Contractor's performance of services under this Agreement. Upon request, Contractor shall furnish to the Authority copies of all Contracts between Contractor and its subcontractors used to perform services for this Agreement.

The Authority reserves the right, at any time during the term of the Agreement, to verify that the written subcontract between Contractor and its subcontractors is in compliance with all of the provisions of this Article 17 and any subcontract provisions contained in this Agreement.

Contractor shall give the Authority immediate notice in writing of the initiation of any legal action or suit which relates in any way to a subcontract with a subcontractor or which may affect the performance of the Contractor's duties under the Agreement. Any subcontract shall not relieve the Contractor in any way of any responsibility, duty and/or obligation of the Agreement.

If at any time during performance under this Agreement total compensation to a subcontractor exceeds or is expected to exceed \$100,000, said subcontractor shall be required to electronically submit and certify a new Vendor Responsibility Questionnaire directly to the Office of the New York State Comptroller, or submit and certify all necessary updated information thereof.

Nothing contained in this Agreement shall create any contractual relationship between a subcontractor and the Authority.

ARTICLE 18. CONFIDENTIALITY AND NON-DISCLOSURE.

- A. "Confidential Information" means any information not generally known to the public, or that the Authority claims is confidential, whether oral, written, or electronic, that the Authority discloses, directly or indirectly, through any means of communication, to Contractor. Confidential Information includes, but is not limited to, operational and infrastructure information relating to: bid documents, plans, drawings, specifications, reports, product information and data; business and security processes and procedures; personnel and organizational data; financial statements; information system IP addresses, passwords, security controls, architectures and designs; and such other data, information and images that the Authority deems confidential.
- B. Confidential Information does not include information which, at the time of the Authority's disclosure to Contractor: (1) is already in the public domain or becomes publicly known through no act of Contractor; or (2) is already known by Contractor free of any confidentiality obligations.

If Contractor wants to disclose Confidential Information, it shall notify the Authority and specify the Confidential Information it wants to disclose. Contractor may only disclose such Confidential Information if the Authority approves such disclosure in writing, subject to such other terms and conditions as the Authority may require. Such approval, if given, shall only apply to the particular request and the specific Confidential Information for

which it is given.

If Contractor is required to disclose or make available, directly or indirectly, Confidential Information pursuant to statute, court or administrative order, subpoena, contractual obligation, or otherwise by law, Contractor shall: (1) notify the Authority that it has received such legal demand as soon as practicable, but in all events prior to any disclosure; (2) permit the Authority to take the steps it deems necessary and appropriate to protect the Confidential Information from disclosure; (3) cooperate to the fullest extent possible under the law with the Authority's efforts to protect the Confidential Information from disclosure; and (4) disclose only such Confidential Information, and only such portions thereof, as is required to satisfy the legal demand, and limit any such disclosure of Confidential Information to the fullest extent permissible under the law.

- C. Contractor may use Confidential Information solely for the purposes of providing services to the Authority pursuant to this Agreement. Contractor may make copies of Confidential Information but only to the extent necessary for the disclosures and uses permitted by this Agreement. Contractor will make commercially reasonable efforts to ensure that any copy of Confidential Information that is made is marked to show that it is or contains Confidential Information. Contractor may share Confidential Information with third parties: (i) that are required for Contractor's provision of services to the Authority pursuant to this Agreement (e.g., Contractors and subcontractors); and (ii) that agree in writing to be bound by the confidentiality provisions of this Agreement; however, Contractor may share only that Confidential Information that is necessary to the third party's contribution to Contractor's provision of services to the Authority pursuant to this Agreement and Contractor must first obtain the Authority's prior written consent.

The Authority's disclosure of Confidential Information to Contractor shall not convey to Contractor any right, title, or interest in or to such Confidential Information, and this Agreement does not transfer ownership of Confidential Information or grant a license thereto. The Authority shall retain all right, title, and interest in and to all such Confidential Information at all times.

- D. Contractor shall hold Confidential Information confidential to the maximum extent permitted by law. Contractor shall safeguard Confidential Information with at least the same level of care and security that Contractor uses to maintain and protect from disclosure its own confidential information, using all reasonable and necessary security measures, devices, and procedures that Contractor uses to maintain its own confidential information, but in all events with not less than reasonable care.

Contractor shall take reasonable steps to prevent unauthorized access to, use of, or disclosure of Confidential Information, including without limitation, by protecting its passwords and other log-in information. Contractor shall notify the Authority immediately of any known or suspected misuse or misappropriation of Confidential Information and shall use its best efforts to stop said misuse or misappropriation.

- E. Upon written request of the Authority, or upon expiration or termination of this Agreement, Contractor shall return all Confidential Information to the Authority, or certify in writing that it has been destroyed and no copies exist.
- F. Contractor agrees that breach of this Article 18 would cause the Authority irreparable

injury, for which monetary damages would not provide adequate compensation, and that in addition to any other remedy, the Authority will be entitled to injunctive relief against such breach or threatened breach, without proving actual damages or posting a bond or other security.

- G. Without limiting the foregoing, the obligations and assurances involving Confidential Information pursuant to this Agreement shall survive termination or expiration of this Agreement.

ARTICLE 19. NEW YORK STATE HUMAN RIGHTS LAW, ARTICLE 15 OF THE EXECUTIVE LAW.

The New York State Human Rights Law, Article 15 of the Executive Law, prohibits discrimination (including to refuse to hire or employ or to bar or to discharge from employment an individual or to discriminate against such individual in compensation or in terms, conditions or privileges of employment) and harassment based on age, race, creed, color, national origin, sex, , sexual orientation, gender identity or expression, disability, marital status, familial status, domestic violence victim status, prior arrest or conviction record, military status or predisposing genetic characteristics, or because the individual has opposed any practices forbidden under the Human Rights Law or because the individual has filed a complaint, testified or assisted in any proceeding under the Human Rights Law, regardless of whether such harassment would be considered severe or pervasive under precedent applied to harassment claims. Harassment is an unlawful discriminatory practice when it subjects an individual to inferior terms, conditions or privileges of employment because of the individual's membership in one or more of these protected categories.

The Human Rights Law may also require reasonable accommodation for persons with disabilities and pregnancy-related conditions. A reasonable accommodation is an adjustment to a job or work environment that enables a person with a disability to perform the essential functions of a job in a reasonable manner. The Human Rights Law may also require reasonable accommodation in employment on the basis of Sabbath observance or religious practices.

Generally, the Human Rights Law applies to:

- all employers of four or more people, employment agencies, labor organizations and apprenticeship training programs in all instances of discrimination or harassment;
- employers with fewer than four employees in all cases involving sexual harassment; and,
- any employer of domestic workers in cases involving sexual harassment or harassment based on gender, race, religion or national origin.

In accordance with New York State Executive Order No. 177, by execution of this Agreement, Contractor hereby certifies, that it does not have institutional policies or practices that fail to address the harassment and discrimination of individuals on the basis of their age, race, creed, color, national origin, sex, sexual orientation, gender identity, disability, marital status, military status, or other protected status under the Human Rights Law.

Executive Order No. 177 and the aforementioned certification do not affect institutional policies or practices that are protected by existing law, including but not limited to the First Amendment of the United States Constitution, Article 1, Section 3 of the New York State Constitution, and Section 296(11) of the New York State Human Rights Law.

ARTICLE 20. DEBARMENT CERTIFICATION.

A. The Contractor certifies to the best of its knowledge and belief, that it and its principals:

1. Are not presently debarred, suspended, proposed for debarment, declared ineligible, or voluntarily excluded from participating in covered transactions by any Federal department or agency;
2. Have not within a three-year period preceding this contract been convicted of or had a civil judgment rendered against them for commission of fraud or a criminal offense in connection with obtaining, attempting to obtain, or performing a public (Federal, State, or local) transaction or contract under a public transaction; violation of Federal or State antitrust statutes or commission of embezzlement, theft, forgery, bribery, falsification or destruction of records, making false statements, or receiving stolen property;
3. Are not presently indicted for or otherwise criminally or civilly charged by a governmental entity (Federal, State or local) with commission of any of the offenses enumerated in paragraph (A)(2) of this certification; and
4. Have not within a three-year period preceding this application/proposal/contract had one or more public transactions (Federal, State or local) terminated for cause or default.

ARTICLE 21. CONFLICTS OF INTEREST.

- A. Contractor has provided as Exhibit V (attached hereto and made a part of this Agreement), the Vendor Assurance of No Conflict of Interest or Detrimental Effect form, signed by an authorized executive or legal representative attesting that Contractor's performance of the services does not and will not create a conflict of interest with, nor position Contractor to breach any other contract currently in force with the Authority or the State of New York, that Contractor will not act in any manner that is detrimental to any Authority or State of New York project for which Contractor is rendering services.
- B. Contractor hereby reaffirms the attestations made in its proposal and covenants and represents that there is and shall be no actual or potential conflict of interest that could prevent Contractor's satisfactory or ethical performance of duties required to be performed pursuant to the terms of this Agreement. Contractor hereby agrees it shall have a continuing affirmative duty and obligation to notify the Authority immediately of any actual or potential conflicts of interest.
- C. In conjunction with any subcontract under this Agreement, Contractor shall obtain and deliver to the Authority, prior to entering into a subcontract, a Vendor Assurance of No Conflict of Interest or Detrimental Effect form, signed by an authorized executive or legal representative of the subcontractor. Contractor shall also require in any subcontracting agreement that the subcontractor, in conjunction with any further subcontracting agreement, obtain and deliver to the Authority a signed and completed Vendor Assurance of No Conflict of Interest or Detrimental Effect form for each of its subcontractors prior to entering into a subcontract.
- D. The Authority and Contractor recognize that conflicts may occur in the future because

Contractor may have existing, or establish new, relationships. The Authority will review the nature of any relationships and reserves the right to terminate this Agreement for any reason, or for cause, if, in the judgment of the Authority, a real or potential conflict of interest cannot be cured.

ARTICLE 22. ETHICS.

Contractor and subcontractors may hire former State agency or Authority employees. However, as a general rule and in accordance with New York Public Officers Law, former employees of the Authority may neither appear nor practice before the Authority, nor receive compensation for services rendered on a matter before the Authority, for a period of two years following their separation from Authority service. In addition, former Authority employees are subject to a "lifetime bar" from appearing before the Authority or receiving compensation for services regarding any transaction in which they personally participated or which was under their active consideration during their tenure with the Authority.

During the term of the Agreement, Contractor and its subcontractors shall not engage any person who is, or has been at any time, in the employ of the Authority or New York State to perform services under the Agreement in violation of: the provisions of the Public Officers Law ("POL"); the rules, regulations, opinions, guidelines, or policies promulgated or issued by the New York State Joint Commission on Public Ethics ("JCOPE Regulations"); and any other laws applicable to the service of current or former Authority or New York State employees ("Other Laws," and, together with POL and JCOPE Regulations, collectively, the "Ethics Provisions"). Contractor certifies that all of its employees and employees of any subcontractor who are former employees of the Authority or New York State and who are assigned to perform services under the Agreement shall be assigned in accordance with all Ethics Provisions. Further, during the term of the Agreement, no person who is employed by Contractor or its subcontractors and who is disqualified from providing services under the Agreement pursuant to any Ethics Provisions may share in any net revenues Contractor or its subcontractors derives from the Agreement.

Contractor shall identify and provide the Authority with notice of those employees of Contractor or its subcontractors who are former employees of the Authority or New York State and who will be assigned to perform services under the Agreement, and shall ensure that such employees comply with all applicable laws and prohibitions. The Authority may, request that Contractor provide it with whatever information the Authority deems appropriate about each such person's engagement, work cooperatively with the Authority to solicit advice from the New York State Joint Commission on Public Ethics, and, if deemed appropriate by the Authority, instruct any such person to seek the opinion of the Joint Commission on Public Ethics. The Authority shall have the right to withdraw or withhold approval of any subcontractor if utilizing such subcontractor for any work performed hereunder would be in conflict with any of the Ethics Requirements. The Authority shall have the right to cancel or terminate the Agreement at any time if any work performed under the Agreement is in conflict with any Ethics Provisions.

ARTICLE 23. MINORITY AND WOMEN BUSINESS ENTERPRISE GOALS AND SERVICE DISABLED VETERANS OWNED BUSINESS GOALS.

This Contract is subject to State provisions (including State Executive Law 15-A and 5 NYCRR Parts 140-145) concerning the utilization of Minority-Owned Business Enterprises (MBE) and Women-Owned Business Enterprises (WBE) (collectively M/WBE). All State M/WBE requirements are applicable to this Contract. The approved overall combined MBE and WBE participation goal for the project is established in the Contract Documents.

This Contract is subject to State provisions (including State Executive Law 15-A and 5 NYCRR Parts 140-145) concerning the utilization of Service Disabled Veterans Owned Business (SDVOB). All State SDVOB requirements are applicable to this Contract. The approved overall SDVOB participation goal for the project is established in the Contract Documents.

ARTICLE 24. IRAN DIVESTMENT ACT- SECTION 2879-C OF THE PUBLIC AUTHORITIES LAW.

- A. As used in this Article 24, "person" has the meaning set forth in paragraph (e) of subdivision 1 of Section 165-a of the State Finance Law.
- B. As used in this Article 24 "Contract" means this Agreement.
- C. Contractor hereby provides the following certification: By signing this Contract, each person and each person signing on behalf of any other party certifies, and in the case of a joint bid or partnership each party thereto certifies as to its own organization, under penalty of perjury, that to the best of its knowledge and belief, that each person is not on the list created pursuant to paragraph (b) of subdivision 3 of Section 165-a of the State Finance Law.

ARTICLE 25. COVENANT AGAINST CONTINGENT FEES.

Contractor warrants that it has not employed or retained any company or person, other than a bona fide employee working for Contractor, to solicit or secure this Agreement, and has not paid or agreed to pay any company or person, other than a bona fide employee, any fee, commission, percentage, brokerage fee, gift, or any other consideration, contingent upon or resulting from the award or making of this Agreement. In the event Contractor violates this warranty, Authority shall have the right to terminate this Agreement without liability, or, in its discretion, to deduct from payments otherwise owed to the Contractor for services provided pursuant to this Agreement the full amount of such fee, commission, percentage, brokerage fee, gift or other consideration.

ARTICLE 26. COMPLIANCE MONITORING.

In the event that the Contractor, its affiliates or any subcontractor is or becomes subject to a compliance monitoring requirement consequent to an agreement with a governmental entity at any time prior to completion of the contract, the Contractor shall promptly notify the Authority of the same. Compliance monitoring means any requirement imposed by a governmental entity arising from an investigation of activities of the Contractor, its affiliates, or any subcontractor concerning alleged compliance violations, pursuant to which the subject entity is obligated to allow an independent third party to review, analyze, investigate or report on that entity's future compliance with governmental rules and/or contractual requirements arising from governmental rules. Said notice shall be in writing and shall include (i) a copy of the order, settlement or other document setting forth the requirement to implement a monitoring program and (ii) the specific requirements and conditions of the required program. If the order, settlement or other document is subject to confidentiality protection that cannot be unilaterally waived by the Contractor or the entity that is subject to the requirement, the Contractor shall cause the subject entity to confirm that it is subject to a compliance monitoring requirement

and to provide a confidential summary of the terms and conditions of the monitoring requirement to the Contractor, with a copy to the Authority.

The Contractor shall further cause the subject entity to promptly notify the Contractor, with a copy to the Authority, of any violations of the monitoring program by the subject entity and of any other concerns expressed by the monitor regarding compliance with the monitoring program requirements. In such event, the Contractor shall provide to the Authority a detailed written report as to whether and to what extent, if any, the violation or concerns expressed by the monitor are relevant to the Contractor's compliance with its Contract obligations, or to the performance of work by the Contractor. The Authority shall at all times have the right to independently investigate whether any matter raised by the monitor will have any effect upon the Contractor's compliance with its Contract obligations or performance of work by the Contractor and/or subject entity. If any such violation occurs or concerns expressed by the monitor involve compliance requirements that are deemed by the Authority to be relevant to the Contract, the Authority shall have the right to require the Contractor to institute, at Contractor expense, additional data keeping, reporting, and/or other safeguard measures, including permitting independent auditing and access to pertinent records of the Contractor or the subject entity to mitigate risk that a similar violation will occur on the project or be a cause for concern with respect to the Contractor's performance of its obligations under the Contract. The Authority's audit rights under the Contract shall include the right to audit and access pertinent records of the Contractor or the subject entity relating to compliance issues described herein.

The Authority agrees to take all reasonable measures to maintain the confidentiality (to the extent permitted by law) of any information provided by Contractor and/or the subject entity pursuant to this Article 26 which the Contractor has reasonably designated as confidential, and the provisions of Appendix A, Section 9 of the New York State Thruway Authority Addendum to the Standard Specifications, of the Agreement shall apply with respect to disclosure of any such Records under the Statute (as defined in such section). Any intra-agency written materials prepared by the Authority, or any written inter-agency materials that are in the possession or control of the Authority, to the extent based on information or records designated as confidential or exempt from disclosure under the Statute as provided in the preceding sentence, shall also be designated and treated as such by the Authority to the fullest extent permitted by law. The Authority may disclose any of the aforementioned information, records and materials to the New York State Department of Transportation, provided that the Department agrees to treat such information, records and material in the same manner as required of the Authority under this paragraph.

The rights and remedies granted to the Authority under this Article 26 are in addition to, and not to the exclusion of, any and all of its rights and remedies under the Contract or at law or in equity.

ARTICLE 27. INDEMNIFICATION.

The Contractor shall be responsible for all damage to life and property due to negligent or otherwise tortious acts, errors or omissions of the Contractor in connection with its services under the Contract Documents. To the fullest extent permitted by law: (a) the Contractor shall indemnify, hold harmless, and release the Authority, the State of New York, any municipality in which the Work is being performed; and/or any public benefit corporation, railroad or public utility whose property or facilities are affected by the Work from suits, claims, actions, damages, and costs of every name and description resulting from the Work under this Contract and until the Final Acceptance thereof; (b) with respect to personal injury or property damage occurring after Final Acceptance and not covered by the indemnity in clause Article 27 (a), the Contractor shall indemnify, hold harmless, and release the Authority, the State of New York, any municipality in which the Work is being

performed; and/or any public benefit corporation, railroad or public utility from suits, claims, actions, damages, and costs of every name and description resulting from negligent or otherwise tortious acts, errors or omissions of the Contractor in connection with its services under the Contract Documents; and (c) the Contractor shall indemnify, hold harmless, and release the Authority's Inspector from suits, claims, actions, damages, and costs involving personal injury and property damage resulting from the Contractor's Work under the Contract during its prosecution and until the Final Acceptance thereof. The Authority may retain such monies from the amount due the Contractor as may be necessary to satisfy any claim for damages recovered against the Authority, the State of New York, any municipality in which the Work is being performed, any public benefit corporation, railroad, or public utility whose property or facilities are affected by the Work, or the Authority's Inspectors. The Contractor's obligation under this paragraph shall not be deemed waived by the failure of the Authority to retain the whole or any part of such monies due the Contractor, or where such suit, action, damages, and/or costs have not been resolved or determined prior to release of any monies to the Contractor under the Contract. Such obligation shall not be deemed limited or discharged by the enumeration or procurement of any insurance for liability for damages imposed by law upon the Contractor, Subcontractors, the Authority, the State, any municipality in which the Work is being performed, any public benefit corporation, railroad, or public utility whose property or facilities are affected by the Work, or any Department consultants or contractors working relative to the Project.

The Contractor has the obligation, at its own expense, for the defense of any action or proceeding which may be brought against the parties specified in this Article. This obligation shall include the cost of attorney fees, disbursements, costs, and other expenses incurred in connection with such action or proceeding. The provisions of this Article shall survive the expiration or termination of the Contract.

Without limiting the generality of the foregoing, Contractor's obligation to indemnify, save harmless and release the Persons identified in this article specifically includes any suits, claims, actions, damages, and costs of every name and description resulting from any spill or release or threatened spill or release of a Hazardous Material (i) attributable to the negligence, willful misconduct or breach of contract by Contractor, its Subcontractors or agents, or (ii) which was brought onto the Site by Contractor or any of its Subcontractors or agents.

Notwithstanding the foregoing, the Authority reserves the right to join such action, at its sole expense, when it determines there is an issue involving a significant public interest. Such obligation does not extend to those suits, actions, damages, and costs of every name which arise out of the sole negligence of the Authority, the State of New York, any municipality in which the Work is being performed, any public benefit corporation, railroad, or public utility whose property or facilities are affected by the Work of the Project, or any Authority consultants or Contractors working relative to the Project, their agents, or their employees.

ARTICLE 28. NOTICES REGARDING CLAIMS, LITIGATION AND RULINGS.

The Contractor shall promptly provide written notice to the Authority of all claims, litigation and governmental rulings pertaining to the work where such claims, litigation or rulings could subject the Authority to liability or substantially impair the completion of the Contract work. With such notice, the Contractor shall include a brief summary of the issue involved and the Contractor's position on such issue. Such written notice is additional to and not in place of

any other notices required by the Contract Documents. The Contractor shall cooperate and provide, and shall require all subcontractors to cooperate and provide, such information or records as may be reasonably requested by the Authority concerning such claims, litigation or rulings.

ARTICLE 29. COOPERATION AND FURTHER ASSURANCES.

Contractor shall cooperate and provide, and shall cause all subcontractors to cooperate and provide, such information as is necessary or requested by the Authority to assist or facilitate the submission by the Authority of any documentation, reports or analysis required by the State, and/or any other governmental entity with jurisdiction over the work. The Contractor shall promptly execute and deliver to the Authority all such instruments and other documents and assurances as are reasonably requested by the Authority to further evidence the obligations of the Contractor under the Contract.

ARTICLE 30. SEVERABILITY.

If any clause, provision, section, article or part of any of the Contract Documents is ruled invalid by a court having proper jurisdiction, the invalidity or unenforceability of any such clause, provision, section, article or part shall not affect the validity or enforceability of the balance of the Contract Documents, which shall be construed and enforced as if the Contract Documents did not contain such invalid or unenforceable clause, provision, section, article or part.

Contract Number:

In addition to the acceptance of this contract, I also certify that original copies of this signature page will be attached to all other exact copies of this contract.

IN-WITNESS WHEREOF, the parties hereto have executed this agreement on the day and year first above written.

By: _____
Chief Engineer

: _____
Date

Contractor

Approved as to form

Approved:

Thomas P. DiNapoli
State Comptroller

New York State Attorney General

By: _____

Date: _____

(ACKNOWLEDGMENT BY INDIVIDUAL CONTRACTOR)

STATE OF NEW YORK

COUNTY OF _____ ss.:

On this _____ day of _____, 202_,
before me personally came _____ to me
known and known to me to be the person described in and who executed the foregoing instrument,
and acknowledged that he executed the same.

Notary Public

(ACKNOWLEDGMENT BY CO-PARTNERSHIP CONTRACTOR)

STATE OF NEW YORK

COUNTY OF _____ ss.:

On this _____ day of _____, 202
before me personally came and appeared _____ to me known and known
to me to be the person who executed the above instrument, who, being sworn by me, did for himself
depose and say that he is a member of the firm of _____ consisting of
himself and _____ and that he executed the foregoing instrument in the
firm name of _____ and that he had authority to sign same, and he did duly
acknowledge to me that he executed the same as the act and deed of said firm of
_____, for the uses and purposes mentioned therein.

Notary Public

(ACKNOWLEDGEMENT OF A CORPORATION)

STATE OF NEW YORK }
 }
COUNTY OF }

On this _____ day of _____, 202_,
before me personally came _____, to me known and known to me to
be the person who executed the above instrument, who being duly sworn by me, did depose and
say that he/she resides in _____, that he/she is the
_____ of _____, the corporation
described in and which executed the above instrument, and that he/she signed his/her name thereto
on behalf of said Corporation by order of the Board of Directors of said Corporation.

Notary Public

Exhibit V**Vendor Assurance of No Conflict of Interest or Detrimental Effect**

The undersigned entity (“Contractor”), offering to provide services pursuant to this Agreement, as a contractor, joint venture contractor, subcontractor, or consultant, attests that its performance of the services outlined in this Agreement does not and will not create a conflict of interest with nor position the Contractor to breach any other contract currently in force with the New York State Thruway Authority (“Authority”).

Furthermore, the Contractor attests that it will not act in any manner that is detrimental to any Authority project on which the Contractor is rendering services. Specifically, the Contractor attests and certifies that:

1. The fulfillment of obligations by the Contractor does not violate any existing contracts or agreements between the Contractor and the Authority;
2. The fulfillment of obligations by the Contractor does not and will not create any conflict of interest, or perception thereof, with any current role or responsibility that the Contractor has with regard to any existing contracts or agreements between the Contractor and the Authority;
3. The fulfillment of obligations by the Contractor does not and will not compromise the Contractor’s ability to carry out its obligations under any existing contracts between the Contractor and the Authority;
4. The fulfillment of any other contractual obligations that the Contractor has with the Authority will not affect or influence its ability to perform under the Agreement;
5. During the negotiation and execution of any contract, the Contractor will not knowingly take any action or make any decision which creates a potential for conflict of interest or might cause a detrimental impact to the Authority as a whole including, but not limited to, any action or decision to divert resources from one Authority project to another;
6. In fulfilling obligations under each of its Authority contracts, including this Agreement, the Contractor will act in accordance with the terms of each of its Authority contracts and will not knowingly take any action or make any decision which might cause a detrimental impact to the Authority as a whole including, but not limited to, any action or decision to divert resources from one Authority project to another;
7. No former officer or employee of the Authority or State of New York (“State”) who is now employed by the Contractor, nor any former officer or employee of the Contractor who is now employed by the Authority or State, has played a role with regard to the administration of this contract procurement in a manner that may violate section 73(8)(a) of the New York State Public Officers Law; and
8. The Contractor has not and shall not offer to any employee, member or director of the Authority any gift, whether in the form of money, service, loan, travel, entertainment, hospitality, thing or promise, or in any other form, under circumstances in which it could reasonably be inferred that the gift was intended to influence said employee, member or director, or could reasonably be expected to influence said employee, member or director, in the performance of the official duty of said

employee, member or director or was intended as a reward for any official action on the part of said employee, member or director.

Contractor agrees that the Authority recognizes that conflicts may occur in the future because a Contractor may have existing or new relationships. The Authority will review the nature of any such new relationship and reserves the right to terminate the contract for cause if, in its judgment, a real or potential conflict of interest cannot be cured.

This form must be signed by an authorized executive or legal representative.

Contractor Name

Name of Signatory

Title of Signatory

Signature:

Date:

769

CONTRACT:

COUNTY:

FAITHFUL PERFORMANCE BOND

BOND

Know all men by these presents, that we (hereinafter called the "Principal")

and _____

of _____ (hereinafter called the "Surety") are held and firmly bound unto the New York State Thruway Authority, (hereinafter called the "Authority"), in the full and just sum of _____ good and lawful money of the United States of America for the payment of which said sum of money, well and truly to be made and done, the said Principal binds himself, his heirs, executors, administrators or assignees and the said SURETY binds itself, its successors or assigns, jointly and severally, firmly by these presents.

Signed, sealed and dated this _____ of _____, 202_____,

Whereas, said Principal has entered into a certain written contract bearing date of the _____ day of _____, 202 with the Authority for:

Now, therefore, THE CONDITION OF THIS OBLIGATION IS SUCH that if the said Principal shall well, truly and faithfully perform the work in accordance with the terms of the contract, and with the plans and specifications, and will commence and complete the work within the time prescribed in the contract, on his part to be kept and performed according to the terms and tenor of said contract, and shall protect the said N.Y.S. Thruway Authority against, and pay any excess of cost as provided in said contract, and all amounts, damages, costs and judgments which may be recovered against said N.Y.S. Thruway Authority, N.Y.S. Dept. of Transportation the Commissioner of Transportation and the State of N.Y. or its or any of their officers or agents or which the said aforementioned may be called upon to pay to any person or corporation by reason of any damages, direct or indirect, arising or growing out of the doing of said work, or from the negligence, non-feasance, misfeasance, or malfeasance of any officer, agent or employee of the aforementioned, or suffered or claimed on account of aforesaid work during the time thereof and until the final completion and acceptance of the work, or the manner of doing the same, or the neglect of the said Principal, or his agents, or servants, or the improper performance of the said work by the said Principal, or his agents, or servants, or from any other cause, then this obligation shall be null and void, otherwise to remain in full force and virtue.

In the event of a failure of performance of the contract by the Principal, which shall include, but not be limited to, any breach or default of the contract by the Principal, or in case said contract is forfeited by the Principal in the manner provided for in the contract and the said Surety, for value received, hereby stipulates and agrees, if requested to do so by the Authority, has the option to either remedy the default, or breach or forfeiture of the Principal or take charge and fully perform and complete the work, mentioned and described in said contract and specifications, pursuant to the terms, conditions and covenants thereof and as may be amended, at its own expense. The procedure by which the surety undertakes to discharge its obligations under the bond shall be subject to the advance written approval of the Authority. If the Surety completes the contract, it shall be paid for the actual items of work performed in accordance with the Principal's contract terms and prices. In the event the Surety assumes the rights and obligations of the Principal.

It shall be the duty of the Surety to give unequivocal notice in writing to the Authority, within forty-five (45) days after receipt of written notice from the Authority to the Surety, of the Surety's election to remedy default(s) or breach(es) or forfeiture(s) promptly or to perform and fully complete the contract promptly as provided herein, time being of the essence of this bond. In said notice of election, the Surety shall state the date on which the remedy or performance shall commence. During the period between the Authority's notice and Surety's performance of the contract or remedy of the default, breach or forfeiture, the Surety shall be liable for and agrees to pay any and all reasonable and necessary costs as determined by the Authority to maintain the project site safe and convenient to the public.

It shall also be the duty of the Surety to give prompt notice in writing to the Authority upon completion of the remedy and/or correction of each breach or default or completion of the contract. The surety shall not assert solvency of its Principal or its Principal's denial of default as justification for its failure to give notice of election or for its failure to promptly remedy the breach or default or to complete the contract.

In the event the Surety shall fail to exercise either option or to act promptly then the Authority shall give ten (10) days notice of such failure, both to the Principal and the Surety, and after the expiration of the 10 days the Authority may cause the work to be completed in accordance with the contract, and the Surety and the Principal shall be jointly and severally liable for the amount of the excess cost of completing the contract work beyond the amounts remaining for this contract adjusted for the work actually performed. When the cost of completion of performance by the Obligee is estimated, the Principal and Surety shall pay, free from all liens and encumbrances, the Authority determined estimated completion costs above funds remaining for this contract, to the Authority within 30 days of receipt of the estimate. Adjustment to the Authority's estimated completion cost will be made upon the Authority's final acceptance of the work and appropriate refunds, if any, will be promptly made to the Surety. Any actual costs in excess of the estimated price shall be paid to the Authority promptly on demand. Additionally, Principal and Surety shall be liable for any applicable liquidated and/or engineering costs or damages.

In addition, the said Principal and Surety further agree, as part of this obligation, to pay all damages of any kind to person or property that may result from a failure in any respect to perform and complete said contract including, but not limited to costs necessary to protect the traveling public or to avoid inconvenience to the traveling public, (liquidated damages as provided above) all repair and replacement costs necessary to rectify construction errors, architectural and engineering costs and fees, all Contractor fees, all testing and laboratory fees, and all interest, legal fees and litigation costs incurred by the Authority.

And the said Surety hereby stipulates and agrees that no change, extension, alteration, deduction of addition in or to the terms of the said contract or the plans or specification accompanying the same shall in any wise affect the obligation of said Surety on its bond.

L.S.

(Corporate seal of _____ L.S. Principal

principal if a corporation.) _____ L.S.

(Corporate seal of _____ L.S.
surety.) _____

_____ L.S. Surety

STATE OF NEW YORK
OFFICE OF THE ATTORNEY GENERAL

I hereby approve the foregoing contract and bond as to form and manner of execution.

Dated _____

Attorney General

(ACKNOWLEDGMENT BY PRINCIPAL, UNLESS IT BE A CORPORATION)

STATE OF NEW YORK,

COUNTY OF _____ ss.:

On this _____ day of _____, 202_, before me personally came _____ to me known, to be the person described in and who executed the foregoing instrument and he acknowledged that he executed the same.

Notary Public

(Notary's seal to be attached.)

(ACKNOWLEDGMENT BY PRINCIPAL, IF A CORPORATION)

STATE OF NEW YORK,

COUNTY OF _____ ss.:

On this _____ day of _____, 202_, before me personally came _____ to me known, who being by me duly sworn, did depose and say that he resides in _____, that he is the _____ of _____, the corporation described in and which executed the foregoing instrument: that he knew the seal of the said corporation: that the seal affixed to said instrument was such corporate seal: that it was so affixed by order of the Board of Directors of said corporation, and that he signed his name thereto by like order.

Notary Public

(ACKNOWLEDGED BY SURETY COMPANY)

STATE OF NEW YORK,

COUNTY OF _____ ss.:

On this _____ day of _____, 202_, before me personally came _____ to me known, who being by me duly sworn, did depose and say that he resides in _____, that he is the _____ of _____, the corporation described in and which executed the foregoing instrument: that he knew the seal of the said corporation: that the seal affixed to said instrument was such corporate seal: that it was so affixed by order of the Board of Directors of said corporation, and that he signed his name thereto by like order.

Notary Public

(Notary's seal to be attached.)

(The Surety Company must append statement of its financial condition and a copy of the resolution authorizing the execution of Bonds by officers of the Company.)

NEW YORK STATE THRUWAY AUTHORITY

LABOR AND MATERIAL BOND

Know all men by these presents,

That, _____
(Name of Principal)

of _____

(hereinafter called the Principal, and _____
(Name of Surety Company)

a corporation of the State of _____, authorized to do business in the State of New York, as Surety and whose principal office is located in the City of _____, State of _____ (hereinafter called the Surety), are held and firmly bound unto the NEW YORK STATE THRUWAY AUTHORITY, (hereinafter called the Authority), in the full and just sum of

_____ good and lawful money of the United States of America, for the payment of which said sum of money, well and truly to be made and done, the said Principal and Surety bind themselves, their and each of their heirs, administrators, executors, successors and assigns, jointly and severally, firmly by these presents.

Whereas, said Principal has entered into a certain written contract, with the Authority bearing date _____ day of _____ 202_, with the New York State Thruway Authority for:

Which contract is hereby referred to and made a part here of as fully and to the same extent as if copied at length herein.

Now therefore, the condition of this obligation is such that if the said Principal shall promptly pay all moneys due to all persons furnishing labor and materials to him or his subcontractors in the prosecution of work provided for in said contract. Then this obligation shall be void, otherwise to remain in full force and effect;

Provided, however, that the Comptroller of the State of New York having required the said Principal to furnish this bond in order to comply with the provisions of Section 137 of the State Finance Law, all rights and remedies on this bond shall inure solely to such persons and shall be determined in accordance with the provisions, conditions and limitations of said Section to the same extent as if they were copied at length herein; and

Further, provided, that the place of trial of any action on this bond shall be in the county in which the said contract was to be performed, or if said contract was to be performed in more than one county, then in any such county, and not elsewhere.

SIGNED, SEALED AND DELIVERED THIS _____ day of _____, 202_

(Principal(s) Sign Here)
(Affix Corporate Seal If a Corporation)

(Surety Signs Here)
(Affix Corporate Seal of Surety Co.)

FOR PRINCIPAL'S USE ONLY (Use Only One)

(INDIVIDUAL ACKNOWLEDGMENT)
UNLESS A CORPORATION

STATE OF _____

COUNTY OF _____ ss.:

On this _____ day of _____, 202_, before me personally came _____ to me known and known to me to be the person mentioned and described in and who executed in foregoing instrument and he duly acknowledged to me that he executed the same.

Notary Public

(ACKNOWLEDGEMENT OF A CORPORATION)

STATE OF NEW YORK }
 }
COUNTY OF }

On this _____ day of _____, 202_, before me personally came _____, to me known and known to me to be the person who executed the above instrument, who being duly sworn by me, did depose and say that he/she resides in _____, that he/she is the _____ of _____, the corporation described in and which executed the above instrument, and that he/she signed his/her name thereto on behalf of said Corporation by order of the Board of Directors of said Corporation.

Notary Public

FOR SURETY'S USE ONLY

(SURETY ACKNOWLEDGMENT)

STATE OF _____

COUNTY OF _____ ss.:

On this _____ day of _____, 202_, before me personally came _____ that he is the _____ of the _____ the corporation described in and which executed the above instruments; that he knows the seal of said corporation, that the seal affixed to said instrument is such corporate seal; that it was so affixed by order of the Board of Directors of Said corporation, and that he signed his name thereto by like order.

Notary Public

APPENDIX A**Standard Clauses For New York State Thruway Authority Contracts**

The parties to the attached contract, license, lease, amendment or other agreement of any kind (“the contract” or “this contract”) agree to be bound by the following clauses which are hereby made a part of the contract (the word “Contractor” herein refers to any party and its agents, successors and assigns, other than the Thruway Authority (“Authority”), whether a contractor, licensor, licensee, lessor, lessee or any other party):

1. **NON-ASSIGNMENT CLAUSE.** This contract may not be assigned by the Contractor nor may its right, title or interest therein be assigned, transferred, conveyed, subcontracted, sublet or otherwise disposed of without the previous consent, in writing, of the Authority and any attempts to assign the contract without the Authority’s written consent are null and void.

2. **COMPTROLLER APPROVAL.** Where required by law, this contract may require approval of the State Comptroller and shall not be valid until it has been approved by the State Comptroller and filed in its office.

3. **WORKERS’ COMPENSATION AND DISABILITY BENEFITS.** This contract shall be void and of no force and effect unless the Contractor shall provide and maintain coverage during the life of this contract for the benefit of such employees as are required to be covered by the provisions of the State Workers’ Compensation Law. If employees will be working on, near or over navigable waters, a U.S. Longshore and Harbor Workers’ Compensation Act endorsement must be included.

4. **NON-DISCRIMINATION REQUIREMENTS.** To the extent required by Article 15 of the State Executive Law (also known as the Human Rights Law) and all other State and Federal statutory and constitutional non-discrimination provisions, the Contractor will not discriminate against any employee or applicant for employment because of race, creed, color, sex (including gender identity or expression), national origin, sexual orientation, military status, age, disability, predisposing genetic characteristics, marital status or domestic violence victim status or because the individual has opposed any practices forbidden under the Human Rights Law or has filed a complaint, testified, or assisted in any proceeding under the Human Rights Law. Furthermore, in accordance with State Labor Law §220-e, if this is a contract for the construction, alteration or repair of any public building or public work or for the manufacture, sale or distribution of materials, equipment or supplies, and to the extent that this contract shall be performed within the State of New York, Contractor agrees that neither it nor its subcontractors shall by reason of race, creed, color, disability, sex or national origin: (a) discriminate in hiring against any New York State citizen who is qualified and

available to perform the work; or (b) discriminate against or intimidate any employee hired for the performance of work under this contract. If this is a building service contract as defined in State Labor Law §230, then, in accordance with §239 thereof, the Contractor agrees that neither it nor its subcontractors shall, by reason of race, creed, color, national origin, age, sex or disability: (a) discriminate in hiring against any New York State citizen who is qualified and available to perform the work; or (b) discriminate against or intimidate any employee hired for the performance of work under this contract. The Contractor is subject to fines of \$50 per person per day for any violation of State Labor Law §§220-e or 239 as well as possible termination of this contract and forfeiture of all moneys due hereunder for a second or subsequent violation.

5. **WAGE AND HOURS PROVISIONS.** If this is a public work contract covered by Article 8 of the State Labor Law or a building service contract covered by Article 9 thereof, neither the Contractor’s employees nor the employees of its subcontractors may be required or permitted to work more than the number of hours or days stated in said statutes, except as otherwise provided in the State Labor Law and as set forth in prevailing wage and supplement schedules issued by the State Labor Department. Furthermore, the Contractor and its subcontractors must pay at least the prevailing wage rate and pay or provide the prevailing supplements, including the premium rates for overtime pay, as determined by the State Labor Department in accordance with the State Labor Law. Additionally, effective April 28, 2008, if this is a public work contract covered by Article 8 of the New York State Labor Law, the Contractor understands and agrees that the filing of payrolls in a manner consistent with subdivision 3-a of §220 of the New York State Labor Law shall be a condition precedent to payment by the Authority of any Authority approved sums due and owing for work done on the project.

6. **NON-COLLUSIVE BIDDING CERTIFICATION.** In accordance with State Public Authorities Law §2878, if this contract was awarded based upon the submission of bids, the Contractor warrants, under penalty of perjury, that its bid was arrived at independently and without collusion aimed at restricting competition. The Contractor further warrants that, at the time the Contractor submitted its bid, an authorized and responsible person executed and delivered to the Authority a non-collusive bidding certification on the Contractor’s behalf.

7. **INTERNATIONAL BOYCOTT PROHIBITION.** In accordance with State Labor Law §220-f, if this contract exceeds \$5,000, the Contractor agrees, as a material condition of this contract, that neither the Contractor nor any substantially owned or affiliated person, firm, partnership, or corporation has participated, is participating, or shall

participate in an international boycott in violation of the Federal Export Administration Act of 1979 (50 USC App. §§2401 et seq.) or regulations thereunder. If such Contractor, or any of the aforesaid affiliates of the Contractor, is convicted or is otherwise found to have violated said laws or regulations upon the final determination of the United States Commerce Department or any other appropriate agency of the United States subsequent to the contract's execution, such contract, amendment or modification thereto shall be rendered forfeit and void. The Contractor shall so notify the Authority within five (5) business days of such conviction, determination or disposition of appeal.

8. **SET-OFF RIGHTS.** The Authority shall have rights of set-off. These rights shall include, but not be limited to, the Authority's option to withhold for the purposes of set-off any moneys due to the Contractor under this contract up to any amounts due and owing by the Contractor to the Authority with regard to this contract, or any other contract with the Authority, including any contract for a term commencing prior to the term of this contract, plus any amounts due and owing to the Authority for any other reason including, without limitation, monetary penalties, adjustments, fees, or claims for damages by the Authority and third parties in connection therewith.

9. **RECORDS.** The Contractor shall establish and maintain complete and accurate books, records, documents, accounts and other evidence directly pertinent to performance under this contract (collectively, "Records") for a period of six (6) years (or any other longer period required by law) following final payment or the termination of this contract, whichever is later, and any extensions thereto. The Authority, State Comptroller, State Attorney General and any other person or entity authorized to conduct an examination shall have access to the Records during normal business hours at an office of the Contractor within New York State, or, if no such office is available, at a mutually agreeable and reasonable venue within the State, during the contract term, any extensions thereof and said six (6) year period thereafter, for purposes of inspection, auditing and copying. As used in this clause, "termination of this contract" shall mean the later of completion of the work of the contract or the end date of the term stated in the contract. The Authority will take reasonable steps to protect from public disclosure those Records which are exempt from disclosure under State Public Officers Law §87 ("Statute") provided that: (i) the Contractor shall timely inform an appropriate Authority official, in writing, that said records should not be disclosed; (ii) said records shall be sufficiently identified; and (iii) designation of said records as exempt under the Statute is reasonable. Nothing contained herein shall diminish, or in any way adversely affect, the Authority's right to discovery in any pending or future litigation.

10. **IDENTIFYING INFORMATION AND PRIVACY NOTIFICATION.** All invoices or New York State standard vouchers submitted for payment for the sale of goods or services or the lease of real or personal property to the

Authority must include the payee's identification number, i.e., the seller's or lessor's identification number. The number is either the payee's Federal employer identification number or Federal social security number, or both such numbers when the payee has both such numbers. Failure to include this number or numbers may delay payment. Where the payee does not have such number or numbers, the payee, on its invoice or New York State standard voucher, must give the reason or reasons why the payee does not have such number or numbers.

The authority to request the above personal information from a seller of goods or services or a lessor of real or personal property, and the authority to maintain such information, is found in State Tax Law §5. Disclosure of this information by the seller or lessor to the Authority is mandatory. The principal purpose for which the information is collected is to enable the State to identify individuals, businesses and others who have been delinquent in filing tax returns or may have understated their tax liabilities and to generally identify persons affected by the taxes administered by the State Commissioner of Taxation and Finance. The information will be used for tax administration purposes and for any other purpose authorized by law.

The above personal information is maintained at the New York State Thruway Authority, Department of Finance and Accounts, P.O. Box 189, Albany, New York 12201.

11. **EQUAL EMPLOYMENT OPPORTUNITIES FOR MINORITIES AND WOMEN.** In accordance with State Executive Law §312, if this contract is: (i) a written agreement or purchase order instrument, providing for a total expenditure in excess of \$25,000, whereby the Authority is committed to expend or does expend funds in return for labor, services, supplies, equipment, materials or any combination of the foregoing, to be performed for, or rendered or furnished to the Authority; or (ii) a written agreement in excess of \$100,000 whereby the Authority is committed to expend or does expend funds for the acquisition, construction, demolition, replacement, major repair or renovation of real property and improvements thereon; or (iii) a written agreement in excess of \$100,000 whereby the owner of a State assisted housing project is committed to expend or does expend funds for the acquisition, construction, demolition, replacement, or major repair or renovation of real property and improvements thereon for such project, then the following shall apply and by signing this contract the Contractor certifies and affirms that it is Contractor's equal employment opportunity policy that:

(a) The Contractor will not discriminate against employees or applicants for employment because of race, creed, color, national origin, sex, age, disability, or marital status, and shall make and document its conscientious and active efforts to employ and utilize minority group members and women in its work force on Authority contracts and will undertake or continue existing programs of affirmative action to ensure that minority group members and women are afforded equal

employment opportunities without discrimination. As used in this clause, "affirmative action" shall mean recruitment, employment, job assignment, promotion, upgrading, demotion, transfer, lay-off or termination, and rates of pay or other forms of compensation.

(b) At the request of the Authority, the Contractor shall request each employment agency, labor union, or authorized representative of workers with which it has a collective bargaining or other agreement or understanding, to furnish a written statement that such employment agency, labor union or representative will not discriminate on the basis of race, creed, color, national origin, sex, age, disability or marital status, and that such union or representative will affirmatively cooperate in the implementation of the Contractor's obligations herein.

(c) The Contractor shall state, in all solicitations or advertisements for employees, that in the performance of this contract all qualified applicants will be afforded equal employment opportunities without discrimination because of race, creed, color, national origin, sex, age, disability or marital status.

The Contractor shall include the provisions of (a), (b) and (c) above in every subcontract over \$25,000 for the construction, demolition, replacement, major repair, renovation, planning or design of real property and improvements thereon except where such work is for the beneficial use of the Contractor. Section 312 does not apply to: (i) work, goods or services unrelated to this contract; or (ii) employment outside New York State. The Authority will consider compliance by a Contractor or its subcontractor with the requirements of any Federal law concerning equal employment opportunity which effectuates the purpose of this section. The Authority shall determine whether the imposition of the requirements of the provisions hereof duplicate or conflict with any such Federal law, and if such duplication or conflict exists, the Authority may waive the applicability of §312 of the Executive Law to the extent of such duplication or conflict. The Contractor shall comply with all duly promulgated and lawful rules and regulations of the Department of Economic Development's Division of Minority and Women's Business Development pertaining thereto.

12. CONFLICTING TERMS. In the event of a conflict between the terms of the contract (including any and all attachments thereto and amendments thereof) and the terms of this Appendix A, the terms of this Appendix A shall control.

13. GOVERNING LAW. This contract shall be governed by the laws of the State of New York except where the Federal supremacy clause requires otherwise.

14. LATE PAYMENT. Timeliness of payment and any interest to be paid to the Contractor for late payment shall be governed by State Public Authorities Law §2880 and 21 NYCRR Part 109.

15. NO ARBITRATION. Disputes involving this contract, including the breach or alleged breach thereof, may not be submitted to binding arbitration (except where statutorily authorized) but must, instead, be heard in a court of competent jurisdiction of the State of New York.

16. SERVICE OF PROCESS. In addition to the methods of service allowed by the State Civil Practice Law & Rules, the Contractor hereby consents to service of process upon it by registered or certified mail, return receipt requested. Service hereunder shall be complete upon the Contractor's actual receipt of process or upon the Authority's receipt of the return thereof by the United States Postal Service as refused or undeliverable. The Contractor must promptly notify the Authority, in writing, of each and every change of address to which service of process can be made. Service by the Authority to the last known address shall be sufficient. The Contractor will have thirty (30) calendar days after service hereunder is complete in which to respond.

17. PROHIBITION ON PURCHASE OF TROPICAL HARDWOODS. The Contractor certifies and warrants that all wood products to be used under this contract will be in accordance with, but not limited to, the specifications and provisions of State Finance Law §165 (Use of Tropical Hardwoods) which prohibits purchase and use of tropical hardwoods, unless specifically exempted, by the State or any governmental agency or political subdivision or public benefit corporation. Qualification for an exemption under this law will be the responsibility of the Contractor to establish to meet with the approval of the Authority.

In addition, when any portion of this contract involving the use of woods, whether supply or installation, is to be performed by any subcontractor, the prime Contractor will indicate and certify in the submitted bid proposal that the subcontractor has been informed and is in compliance with specifications and provisions regarding use of tropical hardwoods as detailed in State Finance Law §165. Any such use must meet with the approval of the Authority; otherwise, the bid may not be considered responsive. Under bidder certifications, proof of qualification for exemption will be the responsibility of the Contractor to meet with the approval of the Authority.

18. MACBRIDE FAIR EMPLOYMENT PRINCIPLES. In accordance with the MacBride Fair Employment Principles (Chapter 807 of the Laws of 1992), the Contractor hereby stipulates that the Contractor either (a) has no business operations in Northern Ireland, or (b) shall take lawful steps in good faith to conduct any business operations in Northern Ireland in accordance with the MacBride Fair Employment Principles (as described in State Finance Law §165), and shall permit independent monitoring of compliance with such principles.

19. OMNIBUS PROCUREMENT ACT OF 1992. It is the policy of New York State to maximize opportunities for the

participation of New York State business enterprises, including minority and women-owned business enterprises as bidders, subcontractors and suppliers on its procurement contracts.

Information on the availability of New York State subcontractors and suppliers is available from:

NYS Department of Economic Development
Division for Small Business
30 South Pearl Street – 7th Floor
Albany, NY 12245
Phone: (518) 292-5220
Fax: (518) 292-5884
<http://www.esd.ny.gov>

A directory of certified minority and women-owned business enterprises is available from:

NYS Department of Economic Development Minority and Women's Business Development Division
30 South Pearl Street – 2nd Floor
Albany, NY 12245
Phone: (518) 292-5250
Fax: (518) 292-5803
<http://www.esd.ny.gov>

The Omnibus Procurement Act of 1992 requires that by signing this bid proposal or contract, as applicable, the Contractor certifies that whenever the total bid amount is greater than \$1 million:

(a) The Contractor has made reasonable efforts to encourage the participation of New York State Business Enterprises as suppliers and subcontractors, including certified minority and women-owned business enterprises, on this project, and has retained the documentation of these efforts to be provided upon request to the Authority;

(b) The Contractor has complied with the Federal Equal Opportunity Act of 1972 (P.L. 92-261), as amended;

(c) The Contractor agrees to make reasonable efforts to provide notification to New York State residents of employment opportunities on this project through listing any such positions with the Job Service Division of the NYS Department of Labor, or providing such notification in such manner as is consistent with existing collective bargaining contracts or agreements. The Contractor agrees to document these efforts and to provide said documentation to the Authority upon request; and

(d) The Contractor acknowledges notice that the Authority may seek to obtain offset credits from foreign countries as a result of this contract and agrees to cooperate with the Authority in these efforts.

20. RECIPROCITY AND SANCTIONS PROVISIONS. Bidders are hereby notified that if their principal place of business is located in a country, nation, province, state or

political subdivision that penalizes New York State vendors, and if the goods or services they offer will be substantially produced or performed outside New York State, the Omnibus Procurement Act 1994 and 2000 amendments (Chapters 684 and 383, respectively) require that they be denied contracts which they would otherwise obtain. Contact the Department of Economic Development, Division for Small Business, 30 South Pearl Street, Albany, New York 12245, for a current list of jurisdictions subject to this provision. NOTE: As of October 2019, the list of discriminatory jurisdictions subject to this provision includes the states of South Carolina, Alaska, West Virginia, Wyoming, Louisiana and Hawaii.

21. NON-PUBLIC PERSONAL INFORMATION. The Contractor shall comply with the provisions of the New York State Information Security Breach and Notification Act (General Business Law §899-aa; State Technology Law §208). In addition to any relief or damages that may be imposed pursuant to the provisions of this Act, the Contractor shall be liable for the costs imposed upon the Authority which are associated with breach of the Act if caused by Contractor's negligent or willful acts or omissions, or the negligent or willful acts or omissions of the Contractor's agents, officers, employees or subcontractors.

22. IRAN DIVESTMENT ACT. In accordance with State Public Authorities Law §2879-c, if this is a contract for work or services performed or to be performed, or goods sold or to be sold, the Contractor subscribes and affirms, under penalty of perjury, that: by signing this contract, each person and each person signing on behalf of any other party certifies, and in the case of a joint bid or partnership each party thereto certifies as to its own organization, under penalty of perjury, that to the best of its knowledge and belief that each person is not on the list created pursuant to paragraph (b) of subdivision 3 of §165-a of the State Finance Law, entitled "Entities Determined to be Non-Responsive Bidders/Offerers pursuant to the New York State Iran Divestment Act of 2012" ("Prohibited Entities List") posted at: <https://ogs.ny.gov/list-entities-determined-be-non-responsive-biddersofferers-pursuant-nys-iran-divestment-act-2012>.

For the purposes of this clause, the term "person" shall be as defined in subdivision (1)(e) of §165-a of the State Finance Law.

Contractor further certifies that it will not utilize on this contract any subcontractor that is identified on the Prohibited Entities List. Contractor agrees that should it seek to renew or extend this contract, it must provide the same certification at the time the contract is renewed or extended. Contractor also agrees that any proposed Assignee of this contract will be required to certify that it is not on the Prohibited Entities List before the contract assignment will be approved by the Authority.

During the term of the contract, should the Authority receive information that a person (as defined in State Finance Law § 165-a) is in violation of the above-referenced certifications, the Authority will review such information and offer the person an opportunity to respond. If the person fails to demonstrate that it has ceased its engagement in the investment activity which is in violation of the Act within 90 days after the determination of such violation, then the Authority shall take such action as may be appropriate and provided for by law, rule, or contract, including, but not limited to, imposing sanctions, seeking compliance, recovering damages, or declaring the Contractor in default.

23. OBSERVANCE OF LAWS. The Contractor agrees to observe all applicable Federal, State and local laws and regulations, and to procure all necessary licenses and permits.

24. NO WAIVER OF PROVISIONS. The Authority's failure to exercise or delay in exercising any right or remedy under this contract shall not constitute a waiver of such right or remedy or any other right or remedy set forth therein. No waiver by the Authority of any right or remedy under this contract shall be effective unless made in a writing duly executed by an authorized officer of the Authority, and such waiver shall be limited to the specific instance so written and shall not constitute a waiver of such right or remedy in the future or of any other right or remedy under this contract.

25. ENTIRE AGREEMENT. This contract, together with this Appendix A and any other appendices, attachments, schedules or exhibits, constitutes the entire understanding between the parties and there are no other oral or extrinsic understandings of any kind between the parties. This contract may not be changed or modified in any manner except by a subsequent writing, duly executed by the parties thereto.

26. ADMISSIBILITY OF REPRODUCTION OF CONTRACT. Notwithstanding the best evidence rule or any other legal principle or rule of evidence to the contrary, the Contractor acknowledges and agrees that it waives any and all objections to the admissibility into evidence at any court proceeding or to the use at any examination before trial of an electronic reproduction of this contract, in the form approved by the State Comptroller, if such approval was required, regardless of whether the original of said contract is in existence.

27. CERTIFICATION OF REGISTRATION TO COLLECT SALES AND COMPENSATING USE TAX BY CERTAIN STATE CONTRACTORS, AFFILIATES AND SUBCONTRACTORS. To the extent this agreement is a contract as defined by Tax Law § 5-a, if the Contractor fails to make the certification required by Tax Law § 5-a or if during the term of the contract, the Department of Taxation and Finance or the Authority, as defined by Tax Law § 5-a, discovers that the certification, made under penalty of perjury, is false, then such failure to file or false certification shall be a

material breach of this contract and this contract may be terminated, by providing written notification to the Contractor in accordance with the terms of the agreement, if the Authority determines that such action is in the best interest of the Authority.

28. CONTRACT INVOLVING STEEL PRODUCTS. Contracts involving steel products are subject to Public Authorities Law § 2603-a, and steel products to be provided or incorporated by Contractor must be produced or made in whole or substantial part in the United States as set forth therein.